

RULES
FOR THE CLASSIFICATION OF
SHIPS

PART 12 – ELECTRICAL EQUIPMENT
July 2023

CROATIAN REGISTER OF SHIPPING

Hrvatska (Croatia) • 21000 Split • Marasovićeve 67 • P.O.B. 187
Tel.: (...) 385 (0)21 40 81 11
Fax.: (...) 385 (0)21 35 81 59
E-mail: tech.coord@crs.hr
web site: www.crs.hr

By the decision of the General Committee to the Croatian Register of Shipping,

RULES FOR THE CLASSIFICATION OF SHIPS
Part 12 – ELECTRICAL EQUIPMENT

have been adopted on 26th June 2023 and shall enter into force on 1st July 2023

GENERAL TERMS AND CONDITIONS

(March 2022)

Article 1 GENERAL

1.1 CROATIAN REGISTER OF SHIPPING (hereinafter: the *Register*) shall at all times remain an independent contractor and neither the *Register* nor any of its officers, surveyors, auditors, inspectors, agents, appointers, officers or managers shall act as an employee, servant or agent of any other party in the performance of the Services rendered by the *Register*.

1.2 The *Register* acts as a service provider. The Services provided by the *Register* cannot be construed as a commitment by the *Register* to achieve any result or as a warranty.

1.3 The provision of Services is subject to these General Terms and Conditions. No other terms and conditions shall apply, either expressly or by implication, unless expressly agreed in writing between the Parties.

1.4 These General Terms and Conditions shall be incorporated into, or referred to in any Contract and shall prevail over and exclude any other terms and conditions that the Client may wish to impose.

Any amendments to and/or deviations from these General Terms and Conditions, as well as any additional terms and conditions of the Client, shall be binding or valid only if set forth in writing and duly signed by the authorised representatives of both Parties.

1.5 The invalidity of one or more provisions of these General Terms and Conditions shall not affect the remaining provisions.

1.6 The Client acknowledges that the latest version of these General terms and Conditions and the latest version of applicable Rules apply to the Services provided by the *Register*.

1.7 Definitions in these General Terms and Conditions take precedence over other definitions that may appear in other documents issued by the *Register*.

1.8 The Client should at all times be aware of the provisions of these General Terms and Conditions, as they may be further amended, with their latest up to date version available on the web site of the *Register*.

Article 2 DEFINITIONS

2.1 **Certificate** means either a class certificate or statutory certificate, statement, attestation, statement of compliance, and a report following the Services provided by the *Register*.

2.2 **Certification** means the activity of certification in application of international and national standards and international industry practice provided by the *Register*.

Certification is an appraisal given by the *Register* to the Client and cannot be construed as an implied or express warranty of safety, fitness for purpose, seaworthiness of the vessel or its value for sale, insurance or chartering.

The purpose of Certification is to provide classification and statutory services and assistance to the maritime industry, Flag State Administrations, and regulatory authorities relating to maritime safety and pollution prevention.

2.3 **Classification** includes all activities and Services provided by the *Register* in accordance with the Rules. Classification may or may not be accompanied by the issuance of a Certificate of class with reference to the Rules.

Certificate of class is valid only if issued by the *Register*.

However, Certificate of class should not be construed as a guarantee of the safety, fitness for purpose or seaworthiness of the vessel. It is merely an attestation that the vessel complies with the Rules developed and published by the *Register*.

In addition, the *Register* is not a guarantee of the safety of life or property at sea or the seaworthiness of a vessel because, although the classification of a vessel is based on the assumption that the vessel will be properly loaded, operated, and maintained by competent and qualified personnel, the *Register* has no control over how a vessel is operated and maintained between the periodic surveys it conducts.

2.4 **Statutory certification** means certification made by the *Register* on behalf of the Flag State Administrations when and to the extent that the *Register* has been authorised to do so by the respective Flag State.

Statutory certification and services include the assessment of vessels registered by the Flag State and/or ship management companies to determine whether such ships/companies comply with the applicable requirements of international conventions, codes and national legislation, and the issuance of, or assistance in the issuance of, the appropriate certificates and documents.

Statutory certification includes, but is not limited to, certification, survey, and issuance of statutory certificates on behalf of the Flag State.

In cases where the *Register* acts on behalf of Flag State Administrations, the *Register* shall follow guidance issued by IMO (Resolutions, Circulars, etc.) or by IACS through Unified Interpretations (UI), unless otherwise directed by the Flag State.

2.5 **Client** means the shipowner, company, shipyard and/or party requesting Services or taking ownership of a classed vessel. In cases where shipowners have authorized another party to operate the vessel on their behalf, that party shall be considered as the company.

In addition to the above the Client means the person and/or entity that has requested Services from the *Register* and that has entered into a Contract or an agreement for Services with the *Register*.

2.6 **Parties** means the *Register* and Client together.

2.7 **Party** means the *Register* or the Client.

2.8 **Contract** means the contract in the form of a written agreement between the Client and the *Register* requesting Services, including these General Terms and Conditions and the Rules.

The provisions related to the Contract in these General Terms and Conditions shall apply even if there is no written agreement between the Client and the *Register*.

The Client may request the *Register* in writing to make a change to the contracted Services. However, the *Register* shall not be obligated to accept or execute any such change until a written agreement has been signed with the Client regarding the compensation and the possible impact of the change on the schedule as an addendum to the originally contracted Services.

2.9 **Services** shall mean the services specified in 2.2, 2.3 and 2.4, but also other services related to certification, classification and statutory certification, such as, but not limited to: ISM Code certification, ISPS Code, MLC 2006 certification, fuel oil consumption reporting, IHM certification, approval of manufacturers and service providers, certification of materials and products, training activities, conformity assessment, and any other relevant activities such as third party inspections, testing, shore and shipboard trials.

The Services provided by the *Register* are performed on a random basis and in no case include a full inspection of all items.

The *Register* shall provide the Services in accordance with related Contract(s), the provisions of these General Terms and Conditions, Rules, the international and national standards, the international conventions, the EU Regulations, the Flag State requirements and the industry practices applicable to the particular Service and always assuming that the Client is aware of these standards and the industry practices.

When providing Services, the *Register* does not guarantee the accuracy of the information or advice provided.

In providing Services, the *Register* does not assess compliance with standards other than the Rules, international and national standards, international conventions, EU regulations, Flag State requirements and industry practice, to the extent agreed in writing or specified in the Contract.

2.10 The *Register* means the Croatian Register of Shipping, an entity organized and existing under Croatian law, which, according to the Law on the Croatian Register of Shipping (Official Gazette No. 1996/81, 2013/76 and 2020/62) and the Charter of the *Register*, is an independent, not-for-profit, but public welfare oriented, public foundation that performs tasks:

- classification of sea-going ships,
- statutory certification of sea-going ships on behalf of the Flag State Administrations,
- classification of inland navigation vessels,
- statutory certification of inland navigation vessels,
- statutory certification of recreational crafts,
- certification of materials and products,
- conformity assessment of recreational crafts,
- conformity assessment of marine equipment,
- conformity assessment of pressure vessels,
- certification/registration of quality management systems.

2.11 **Vessel** means a ship, vessel, unit or offshore structure of any kind, whether or not connected to the shore or sea/river bed, located at sea or in inland waters and intended for transportation or special operations on the water, as decided by the *Register*.

2.12 **Rules** means the Rules for the classification, guidelines, instructions, or other documented evidence of the *Register* related to the Services provided.

The competent interpretation of the requirements specified in the Rules or other regulations published by the *Register* shall be the exclusive responsibility of the *Register's* Head Office, notwithstanding any possible different interpretations by other parties.

In cases where the Rules do not contain detailed requirements, the specific approval by the *Register* shall be based on the principles of the Rules and shall ensure a safety standard equivalent to that of the Rules.

Article 3 RESPONSIBILITIES

3.1 It is the Client's responsibility to ensure that all surveys required for vessel's class maintenance are conducted in a timely manner and in accordance with the Rules.

3.2 The *Register* may suspend or withdraw the vessel's existing Certificate of class in the event of serious deficiencies and replace it with a new Certificate of class with a shortened period of validity during which the deficiencies are to be rectified.

In addition, the *Register* shall suspend or withdraw a vessel's Certificate of class if the deficiencies are of such a magnitude as to endanger the class of the vessel, its safety and integrity, the safety of the crew, passengers, or the marine environment, and shall require that the vessel is to be inspected at the first port of call where the necessary repairs are to be carried out.

3.3 The Client should inform the *Register*:

- (i) in the event of a change in the intended use of a vessel, a conversion and alteration of the hull, machinery installations and other equipment affecting the Class of the vessel assigned by the *Register*. Conversions and alterations must be made under the supervision of the *Register* and must comply with the requirements of the Rules and/or additional requirements of the *Register*,
- (ii) in cases where the vessel has been damaged to such an extent that the Class of the vessel is likely to be affected and the safety and integrity of the vessel is likely to be compromised. In such cases, the vessel must be surveyed at the first port of call or as further directed by the *Register*. The survey shall be to the extent deemed necessary by the *Register*, by taking into account the extent of the damage.
- (iii) in cases where class-related deficiencies and/or defects are found as a result of a Flag State inspection or Port State Control. Should the Client fail to notify the *Register* of the detention of the vessel by Port State Authorities due to class related deficiencies, the *Register* reserves the right to suspend or withdraw the Certificate of class.

3.4 The *Register* shall have full control over Certificates issued and may suspend or withdraw a Certificate at any time in its sole discretion if the Client fails to comply with the following requirements set forth in the *Rules for the Classification of Ships, Part 1 - General Requirements, Chapter 1 - General Information*, as applicable:

- (i) para. 5.3 - *Maintenance of the validity of Certificate of Class*,
- (ii) para. 5.4 - *Period of Validity*,
- (iii) para. 5.5 - *Extension of the Period of Validity*,
- (iv) para. 5.6 - *Suspension and Reinstatement of Class in the Case of Overdue Surveys*, and
- (v) para. 5.7 - *Withdrawal of Class*.

3.5 The *Register* may suspend or withdraw a Certificate at any time in its sole discretion if the Client fails to comply with the following requirements set forth in the *Rules for the Classification of Inland Navigation Vessels, Part 1 - Classification and Surveys, Chapter I - Principles of Classification*, as applicable:

- (i) para. 2.8 - *Maintenance of the Validity of the Certificate of Class*,
 - (ii) para. 2.9 - *Extension of validity of the Certificate of Class*,
- and following requirements set forth in the *Rules for the Classification of Inland Navigation Vessels, Part 1 - Classification and Surveys, Chapter II - Classification*, as applicable:

- (iii) para. 2.1 - *Suspension of Class*,
- (iv) para. 2.2 - *Withdrawal of Class*.

3.6 In addition to clauses 3.2, 3.4 and 3.5 of this Article, the *Register* reserves the right to terminate the Services and related Contract in the event of a breach of the provisions of these General Terms and Conditions.

3.7 If the Client fails to provide the *Register* with the required access or information at the agreed times or fails to prepare for the Service in a timely manner, the *Register* may suspend the provision of the Service until it receives the Client's instructions for access and/or the required information.

The *Register* shall not be liable for the consequences of such suspension, and the Client shall be responsible for the *Register's* additional fees and other unnecessary costs and expenses incurred by the *Register*.

3.8 The Client is obliged to perform timely payments of the invoices for provided Services. However, the *Register* may retain or withhold any Service or Certificate to the Client in the case of outstanding payments, whether mutually related or not, arising out of the entire business relationship with the Client.

Article 4 HEALTH, SAFETY AND ENVIRONMENT

4.1 Both the *Register* and the Client shall apply reasonable standards to promote safety, health, and environmental protection and to provide a safe working environment for their personnel.

4.2 The Client shall provide the *Register* with all access and information necessary for the safe and efficient performance of the requested Services as required by the Rules.

4.3 During the survey, personnel of the *Register* should have secure access to all work that directly or indirectly affects the Service.

4.4 The *Register* has the right to refuse to conduct an activity or visit an area or site if the *Register* in its sole discretion, believes that relevant risks are unacceptable or are not adequately addressed, contained, or otherwise mitigated.

Such a decision shall suspend the obligations of both Parties under the Contract without incurring any liability or penalty until the Parties agree on how to proceed.

Article 5 THIRD PARTIES AND SUBCONTRACTORS

5.1 Each specific Contract, including any Certificates issued, relates specifically to the Client, and no rights, obligations, interests, claims, benefits or Certificates issued shall extend to any third party without the prior written consent of the *Register*.

5.2 The Client shall not be entitled to grant any right to use the Certificates to any third party without the prior written consent of the *Register*.

5.3 The Client shall not without *Register's* consent, cede, assign, transfer, subcontract or deal in any manner with all or any of its rights or obligations under any Service and related Contract.

5.4 With regard to third party rights to access information and Certificates under confidentiality clause reference is to be made to Article 9.

Article 6 TAXES

6.1 Each Party shall be responsible for and shall bear all taxes, duties or similar governmental charges levied or imposed on any activity of that Party.

6.2 Prices, fees, rates, or remuneration are exclusive of any form of sales tax, value added tax, administrative fees and services tax and/or other similar taxes, including any surcharges. If any such indirect tax is or becomes applicable to the Services provided under the Contract, the Client shall be responsible for the payment of such indirect taxes.

Article 7 PAYMENT OF INVOICES

7.1 The provision of Services by the *Register*, whether complete or not, shall include payment of fees thirty (30) days after issuance of the invoice for the portion of the Services performed.

7.2 In the event that the Client fails to meet the requirements for payment in accordance with the instalments and terms of payment contained herein, the *Register* reserves the right to charge the Client with the interest rate in accordance with the applicable laws of the Republic of Croatia.

7.3 If the Client disputes an invoice or part of an invoice, the Client shall notify *Register* thereof in writing without undue delay. If no notification is received by the due date, Client shall be deemed to have accepted the invoice in full. If only part of an invoice is disputed, the undisputed amount must be paid by the due date.

Consequently, no disputes arising between the *Register* and the Client shall interfere with prompt payment of invoices by the Client. Any rights of lien or retention in favour of the Client or otherwise, are hereby excluded.

7.4 In the event of cancellation of all or part of the Services prior to their final completion, the Client shall pay all costs incurred by the *Register* on pro-rata basis for the portion of the Services provided to date. In such event, the *Register* will not claim the Client for loss of profit or reduced income. All reasonable costs directly attributable to the early termination and all amounts due to the *Register* at that time shall become immediately due and payable.

7.5 In the event of termination of the Service and related Contract, the *Register* shall be entitled to retain any payments, deposits or prepayments of fees made by the Client prior to the date of termination up to the amount to which the *Register* is entitled.

Article 8 TERMINATION

8.1 The Parties shall have the right to terminate the Services and the related Contract(s) by written notice to the other Party, and without prejudice to Article 7, in the following cases:

- (i) if the other Party commits a material breach of these General Terms and Conditions and/or the Contract and fails to rectify such breach in accordance with clause 8.4 of this Article,
- (ii) if the other Party becomes insolvent, is unable to pay its debts as they become due, or becomes subject to bankruptcy proceedings, administration, receivership, dissolution, liquidation, winding up or otherwise ceases to carry on its business; or
- (iii) for convenience, after giving the other Party thirty (30) days' prior written notice of termination.

8.2 The Classification issued for the relevant vessel and the Certificates previously issued shall remain valid until the effective date of termination or, in the event of such termination, immediately, subject to compliance with Article 3 and Article 7.

8.3 If, in the reasonable opinion of the *Register*, the Client breaches or is suspected of breaching Article 14 or Article 15, the *Register* shall have the right to terminate the Service and related Contract with immediate effect.

8.4 Notwithstanding the provisions of clause 8.1 of this Article, the Party intending to terminate Services for non-compliance or breach of the provisions of these General Terms and Conditions shall notify the other Party of the non-compliance or violation of the provisions of these General Terms and Conditions and set a reasonable deadline of 15 (fifteen) days for the other Party to remedy the breaches of the provisions of these General Terms and Conditions.

If the Party fails to remedy the breaches of the provisions of these General Terms and Conditions within the aforementioned period, the other Party shall have the right to terminate Services without further notice.

8.5 Termination of the Service and related Contract pursuant to the provisions of these General Terms and Conditions shall not give either Party the right to claim any additional compensation, indemnity or reimbursement from the other Party as a result of such termination, but such termination shall not affect any rights or remedies available to a Party at the time the termination becomes effective or any obligations or liabilities incurred by a Party.

Article 9 CONFIDENTIALITY

9.1 The Parties agree to keep confidential all facts, data, information, etc. related to the other Party's business that they have learned in the course of providing Services. Such information and data shall not be disclosed by the Parties to any third party and shall not be used or misused to the detriment of the other Party.

9.2 The *Register* will keep confidential any data, plans or other technical information received from the Client and will not disclose it to any third party outside the *Register*, unless authorised by the Client. This obligation shall continue to apply after termination of the Services. This obligation shall not apply to any data, plans or other technical information that was in the possession of the *Register* prior to being disclosed to the *Register* by or on behalf of the Client, or that becomes publicly available through no fault of the *Register*, or is otherwise provided to the *Register* by an independent source that is under no obligation of confidentiality to the *Register*.

9.3 Certificates issued by the *Register* to the Client as a result of the Services provided shall not be covered by the confidentiality Article.

Notwithstanding the foregoing, the Client shall be entitled to disclose any data to its affiliates involved in the transactions related to the Services or the Client's core activities.

9.4 Notwithstanding clause 9.1 and clause 9.2 of this Article, the *Register* shall have the right to disclose the Confidential Information to the following parties if required by regulations of:

- (i) authorised representatives of the Flag State Administration,
- (ii) authorised audit teams (i.e., accreditation body or EC auditors),
- (iii) the International Association of Classification Societies (IACS),
- (iv) a court of competent jurisdiction, government agency, or other relevant public authority, in accordance with applicable law, court order, or other public regulation.

9.5 The Client acknowledges that the *Register* is required to provide access to information to the EU Commission or any person acting on its behalf in accordance with applicable EU requirements and that the Client shall give the EU Commission with unrestricted access to the vessels for the purpose of inspection.

9.6 The obligations in this Article shall survive the conclusion of the Service or the termination of related Contract and shall continue for as long as the relevant information remains confidential.

Article 10 INTELLECTUAL PROPERTY

10.1 Each Party shall be the sole owner of all rights to its Intellectual Property created before or after the effective date of these General Terms and Conditions, whether or not associated with any Contract between the Parties.

10.2 The Intellectual Property developed by the *Register* for the provision of the Services, including but not limited to drawings, calculations and reports, shall remain the exclusive property of the *Register*.

Article 11 PROFESSIONAL ETHICS

11.1 Each of the Parties warrants that, with respect to the matters contemplated herein, neither it nor its affiliates has made or will make, directly or indirectly, any offer, payment, gift or authorization of money to any government official or employee, political party, public official or candidate for the benefit or advantage thereof.

11.2 In providing the Services, the *Register* shall strictly adhere to the requirements of its Code of Ethics relating to business activities.

Article 12 FORCE MAJEURE

12.1 For the purposes of these General Terms and Conditions, the term "Force Majeure" includes any event that directly or indirectly prevents the Parties from fulfilling their obligations due to events beyond their control, such as: strikes, wars, riots, piracy, civil commotion, malicious damage, pandemic, compliance with laws or government orders, rules, regulations or directives, sanctions and embargoes, accidents, defects of plants or machinery, seizures, fires, floods, storms and the like.

12.2 If either Party is prevented or delayed from performing its obligations by Force Majeure, such Party shall promptly notify the other Party in writing of the circumstances of the Force Majeure and its influence and, after such notification, shall not be liable for performance of any obligations prevented by the influence of the Force Majeure during its duration. Upon termination of the influence of the Force Majeure, the same Party should proceed with the planned activities in order to fulfil its obligations.

12.3 If one of the Parties is prevented by Force Majeure in its activities and fulfilment of its obligations and this event lasts continuously for three (3) months, the other Party shall be entitled to terminate the Service and related Contract without liability.

12.4 Neither of the Parties shall be liable for non-compliance with these General Terms and Conditions due to Force Majeure. If one of the Parties is prevented from fulfilling its obligations under these General Terms and Conditions due to Force Majeure, it shall immediately notify the other Party in writing within a reasonable period of time, stating the reasons for the Force Majeure and providing relevant evidence, if any.

Article 13 INDEMNIFICATIONS

13.1 Each Party shall indemnify the other Party against all claims arising out of the performance of the Services in respect of bodily injury, illness or death of any of its employees or other representatives and in respect of loss of or damage to the Party's property.

This provision shall apply whether or not the damage is caused or contributed to by the negligence of the other Party. Both Parties are obliged to take out separate insurances for these liabilities.

13.2 The Client shall indemnify the *Register* from and against all claims arising from the Client's violation of the provisions of these General Terms and Conditions and from the misuse of the Certificates issued by the *Register*.

13.3 The Client shall indemnify the *Register* against any financial responsibility or amounts arising from non-payment, late payment or payment of withholding taxes to the non-relevant tax authority or any other relevant governmental body.

13.4 Each Party shall notify the other Party without undue delay as soon as it becomes aware of any incident that could give rise to a claim against the other Party in respect of the Service provided and related Contract.

Article 14 ANTI-CORRUPTION

14.1 Each Party agrees that in performing its obligations under any Service, it will ensure that its affiliates, employees and/or agents, subsidiaries, subcontractors, consultants, and any other persons providing Services will:

- (i) comply with all applicable anti-bribery and anti-corruption laws (collectively, Anti-Bribery Laws) and, in particular, do not, directly or indirectly, offer, promise, grant, authorise the payment of, or confer any financial or other benefit on any public or government official:
 - to a public or governmental official to obtain or retain business with the intent to influence such official in his or her capacity as an official, if such official is not permitted or required by written law to be influenced by the offer, promise or gift; or
 - to another person with the intent to induce or reward the improper performance of a function or activity or for any other illegal purpose,
- (ii) maintain adequate systems and procedures designed to prevent activities, practises, or conduct in connection with services that would constitute an offence under an anticorruption law; and
- (iii) take reasonable steps to prevent similar acts by customers, contractors, subcontractors, agents and other third parties, persons under its control or influence.

14.2 Any failure by a Party to comply with or ensure compliance with its obligations under this Article shall, notwithstanding anything to the contrary in these General Terms and Conditions, be deemed a breach of these General Terms and Conditions which shall entitle the other Party to suspend and/or terminate the Services by notice in writing with immediate effect without further liability to the other Party except for any liability which may have arisen prior to the date of termination or suspension (as the case may be).

14.3 If a Party elects to suspend the provision of Services under these General Terms and Conditions pursuant to this Article, it shall have the sole and absolute discretion to determine:

- (i) when it will resume performance (if at all); and
- (ii) extend the period for performance of its obligations under the Services in its sole discretion.

Article 15 SANCTIONS

15.1 Each Party shall conduct all activities in compliance with all laws, statutes, rules, economic and trade sanctions (including, but not limited to, U.S. sanctions and EU sanctions) and regulations applicable to such Party, including, but not limited to: child labour, forced labour, collective bargaining, discrimination, abuse, working hours and minimum wages, anti-bribery, anti-corruption, copyright and trademark protection, personal data protection.

15.2 Each Party hereby represents and warrants that it is not or will not be subject to any economic or trade sanctions ("Sanctions") imposed by the United States of America, the European Union, the United Kingdom, any EU Member State, or the United Nations with respect to any country and/or by any sanction giver with respect to any company/individual.

15.3 Each Party represents and warrants that it will strictly comply with all Sanctions.

15.4 Nothing in these General Terms and Conditions shall be construed as causing or obligating either Party to act or refrain from acting in a manner inconsistent with, punishable by, or prohibited by any Sanctions.

15.5 Neither Party shall be obligated to perform any obligation arising under these Terms and Conditions (including, without limitation, the obligation to):

- (i) perform, deliver, accept, sell, purchase, pay or receive any funds to, from or through any person or entity; or
- (ii) engage in any other action whatsoever, if doing so violates or is inconsistent with sanctions and/or recommendations of international (intergovernmental) organisations to combat the financing of terrorism and other criminal activities and/or money laundering or exposes such Party to investigation or penalties.

15.6 In the event that a Party breaches any Sanctions or the Party's Business and/or Transactions arising out of or in connection with these General Terms and Conditions breach any Sanctions or otherwise violate the recommendations of one or more international (intergovernmental) organisations for combating the financing of terrorism and other criminal activities and/or money laundering, the other Party shall be entitled to terminate these General Terms and Conditions by written notice with immediate effect without incurring any liability to the other Party, except for liabilities (if any) incurred prior to the date of termination.

Article 16 LIABILITY

16.1 The *Register* is not, and cannot be considered as, an underwriter, consulting engineer, naval architect, shipbuilder, shipowner, or ship management company, nor can it assume the obligations and responsibilities associated with such functions, although the *Register's* experience may enable it to respond to inquiries about matters not covered by its Rules, policies, instructions, or other documented evidence.

16.2 The practices and procedures of the *Register* shall be selected by the *Register* in its sole and absolute discretion based on its experience and knowledge and in accordance with generally accepted professional standards in the relevant field of classification societies.

16.3 Nothing herein contained shall release any designer, naval architect or engineer, shipbuilder or manufacturer, shipyard, vendor, supplier, contractor or subcontractor, repairer or owner, from any information, report, certificate or similar document issued in connection with the provision of Services by the *Register*, operator, manager or other person or entity from any express or implied warranty or other contractual obligation or responsibility, or from any negligent act, error or omission of any kind whatsoever, nor shall they create any right, claim or benefit for any third party.

16.4 The *Register* shall exercise due care in the selection or appointment of its surveyors and all other employees whose presence and work is necessary for the provision of the Services.

16.5 If any person or entity using the Services of the *Register* suffers any loss, damage or expense that is or is shown to have been caused by a negligent act, omission or error of the *Register's* officers, surveyors, auditors, inspectors, agents, appointees, officers or managers, or those purporting to act in the name of and on behalf of the *Register*, or a negligent inaccuracy, advice, report or evidence given by or in the name of or/and on behalf of the *Register*, then the liability of the *Register* is limited in respect of any direct or indirect claim shall be limited to an amount not exceeding five times the fee charged or to be charged by the *Register* for the relevant Service.

16.6 Any liability for consequential damages is expressly excluded.

For purposes of this clause, consequential damages include, without limitation:

- (i) indirect or consequential damages,

- (ii) loss and/or delay of production, loss of products, loss of use, loss of bargain, loss of revenue, loss of profit or anticipated profit, loss of business and business interruption, in each case directly or indirectly.

16.7 The Parties are not entitled to assign the performance of obligations under these General Terms and Conditions or parts thereof to third parties without the prior written consent of the other Party.

16.8 If during the term of the Contract, there is a transfer of function due to change of status (merger, acquisition, division, etc.), all obligations and rights under these General Terms and Conditions and associated Contract will be transferred to the legal successor of the Party concerned.

Article 17 GOVERNING LAW AND RESOLVING OF DISPUTES

17.1 These General Terms and Conditions and any dispute or claim between the Parties arising from or in connection with it, or the Services provided hereunder, will be governed and interpreted in accordance with the English law.

17.2 The Parties shall use their reasonable efforts to resolve any claim or dispute arising in relation to rendered Service by negotiations within a reasonable time.

17.3 Should the Parties fail to resolve any claim or dispute by negotiations, the dispute shall be exclusively subject to the jurisdiction of the Permanent Arbitration Court with the Croatian Chamber of Economy in Zagreb, Republic of Croatia.

17.4 The Parties agree to keep the any arbitration proceedings confidential.

17.5 Notwithstanding the above, any claim not presented within three (3) months of the completion of the particular Services, or within three (3) months of from the date when the events which are relied on were first discovered by the Client, shall be deemed waived and absolutely time barred.

17.6 Any objections against the line adopted by any of the *Register's* servants in fulfilling their duties or against the conclusions reached are to be raised to the *Register* by the Party as soon as possible.

If the Party is not satisfied with the final conclusions and interpretations by the *Register* the arbitration lays upon the Commission for appeal for Classification and Statutory certification of ships, which is to be formed according to the Regulation 39 of the Charter of the *Register*.

REVIEW OF AMENDMENTS IN RELATION TO PREVIOUS EDITION OF THE RULES

RULES FOR THE CLASSIFICATION OF SHIPS ***Part 12 – ELECTRICAL EQUIPMENT***

All major changes in respect to the Rules for the classification of ships, Part 12 – Electrical equipment, edition 2020, as last amended by Amendments No. 4, edition January 2023 throughout the text are shaded (if any).

Items not being indicated as corrected have not been changed.

The grammar and print errors, have been corrected throughout the Rules and are not subject to above indication of changes.

This Part of the Rules includes the requirements of the following international Organizations:

International Maritime Organization (IMO)

Conventions: International Convention for the Safety of Life at Sea, 1974 (SOLAS 74) and all subsequent and applicable amendments adopted up to MSC 106
Protocol of 1988 relating to the International Convention for the Safety of Life at Sea, 1974, as amended (SOLAS PROT 1988)

International Association of Classification Societies (IACS)

Unified Requirements (UR):

E5 (Rev.1, 2005), E7 (Rev.5, 2021), E9 (Rev.1, 2012), E10 (Rev.8 Corr.1, 2022), E11 (Rev.4, 2021), E12 (Rev.2, 2020), E13 (Rev.3 Corr.1, 2022), E15 (Rev.4, 2020), E16 (2002), E17 (Rev.1, 2021), E18 (Rev.1, 2014), E19 (Rev.1, 2005), E20 (Rev.1, 2009), E21 (Rev.1 Corr.1, 2022), E22 (Rev.2, 2016), E24 (Rev.1, 2018), E25 (Rev.2, 2022), M64 (Rev.1, 2004)

Unified Interpretations (UI):

SC1 (Rev.2, 2021), SC3 (Rev.1, 1999), SC4 (1985), SC5 (1985), SC6 (Rev.1, 2019), SC7 (1985), SC8 (1985), SC9 (1985), SC10 (Rev.3, 2021), SC11 (Rev.1, 2021), SC12 (1985), SC13 (1985), SC17 (Rev.3, 2020), SC70 (Rev.4 Corr.1, 2023), SC83 (1993), SC94 (Rev.2 Corr.1, 2018), SC95 (1994), SC124 (Rev.1 Corr.1, 2007), SC134 (2002), SC136 (Rev.3, 2005), SC151 (1999), SC152 (1999), SC157 (Rev.1, 2005), SC176 (Rev.1, 2004), SC180 (Rev.4, 2021), SC184 (Rev.1, 2005), SC185 (Rev.1, 2005), SC186 (Corr.1, 2010), SC187 (2004), SC194 (Rev.1, 2021), SC 274 (Rev.1, 2021), SC290 (2018)

Unified Recommendations:

Rec. 73 (Rev.2, 2023), Rec. 35 (Rev.2, 2021), Rec. 120 (2015)

Contents

Page

1	GENERAL PROVISIONS.....	1
1.1	APPLICATION	1
1.2	DEFINITIONS AND EXPLANATIONS.....	1
1.3	SCOPE OF SUPERVISION AND TECHNICAL DOCUMENTATION	3
2	CONSTRUCTION OF ELECTRICAL EQUIPMENT.....	5
2.1	OPERATING CONDITIONS.....	5
2.2	ELECTROMAGNETIC COMPATIBILITY.....	6
2.3	MATERIALS	7
2.4	STRUCTURAL REQUIREMENTS AND DEGREE OF MECHANICAL PROTECTION OF ELECTRICAL EQUIPMENT.....	8
2.5	PROTECTIVE EARTHING.....	11
2.6	LIGHTNING PROTECTION.....	13
2.7	ARRANGEMENT OF ELECTRICAL EQUIPMENT.....	14
2.8	SPECIAL ELECTRICAL SPACES	14
2.9	SAFE-TYPE ELECTRICAL EQUIPMENT	14
2.10	ON BOARD USE AND APPLICATION OF COMPUTER BASED SYSTEMS	17
2.11	HARMONIC DISTORTION FOR SHIP ELECTRICAL DISTRIBUTION SYSTEM INCLUDING HARMONIC FILTERS	23
3	MAIN ELECTRICAL POWER SOURCES	24
3.1	NUMBER AND POWER OF ELECTRICAL SOURCES.....	24
3.2	ELECTRICAL GENERATING SETS	25
3.3	NUMBER AND POWER OF TRANSFORMERS	26
3.4	POWER SUPPLY FROM EXTERNAL SOURCE OF ELECTRICAL POWER.....	26
3.5	CONNECTIONS OF ELECTRICAL POWER SUPPLY SOURCES.....	27
4	DISTRIBUTION OF ELECTRICAL POWER	28
4.1	DISTRIBUTION SYSTEMS.....	28
4.2	PERMISSIBLE VOLTAGES	28
4.3	POWER SUPPLY OF ESSENTIAL CONSUMERS	28
4.4	POWER SUPPLY OF ELECTRICAL AUTOMATION SYSTEMS.....	29
4.5	POWER SUPPLY OF SHIP CONTROL CONSOLES.....	29
4.6	SWITCHING EQUIPMENT	30
5	ELECTRICAL DRIVES FOR SHIP MECHANISMS AND EQUIPMENT	35
5.1	GENERAL.....	35
5.2	INTERLOCKING OF MACHINERY OPERATION	35
5.3	SAFETY TRIPPING DEVICES.....	35
5.4	DEVICES FOR STARTING, REVERSING AND REGULATION	35
5.5	ELECTRICAL DRIVE AND CONTROL OF STEERING GEAR.....	35
5.6	ELECTRICAL DRIVES FOR ANCHOR AND MOORING MACHINERY	39
5.7	ELECTRICAL DRIVES FOR PUMPS.....	39
5.8	ELECTRICAL DRIVES OF FANS.....	39
5.9	ELECTRICAL DRIVES FOR LIFE BOAT WINCHES.....	39
5.10	ELECTRICAL DRIVES OF WATERTIGHT AND FIRE DOORS	39
5.11	ELECTRICAL DRIVES OF ACTIVE MEANS OF SHIP STEERING.....	40
5.12	INSTALLATION OF ELECTRICAL AND ELECTRONIC EQUIPMENT IN ENGINE ROOMS PROTECTED BY FIXED WATER-BASED LOCAL APPLICATION FIRE-FIGHTING SYSTEMS(FWBLAFFS)	40
5.13	REQUIREMENTS FOR UNINTERRUPTIBLE POWER SYSTEM (UPS) UNITS AS ALTERNATIVE AND/OR TRANSITIONAL POWER	41
6	LIGHTING.....	42
6.1	GENERAL REQUIREMENTS	42
6.2	POWER SUPPLY OF MAIN LIGHTING CIRCUITS	42
6.3	EMERGENCY LIGHTING.....	42
6.4	SWITCHES IN LIGHTING CIRCUITS	43
6.5	GAS DISCHARGE LIGHTING FIXTURES.....	43
6.6	SOCKETS AND PLUGS	43
6.7	ILLUMINATION.....	43
6.8	SIGNAL AND NAVIGATIONAL LIGHTS.....	44

7	INTERNAL COMMUNICATION, ALARMS AND SIGNALLING.....	45
7.1	GENERALLY.....	45
7.2	ELECTRICAL ENGINE ROOM TELEGRAPH.....	45
7.3	INTERNAL SERVICE COMMUNICATION.....	45
7.4	GENERAL ALARM SYSTEM.....	46
7.5	FIRE DETECTION AND ALARM SYSTEMS.....	46
7.6	WARNING ALARM OF FIRE SMOTHERING SYSTEM RELEASE.....	47
7.7	INDICATION OF CLOSURE OF WATERTIGHT AND FIRE DOORS.....	47
7.8	SIGNALS IN ENGINEERS' ACCOMMODATION SPACES.....	48
8	PROTECTION.....	49
8.1	GENERAL REQUIREMENTS.....	49
8.2	PROTECTION OF GENERATORS.....	49
8.3	PROTECTION OF ELECTRICAL MOTORS.....	50
8.4	STEERING GEAR ELECTRICAL EQUIPMENT PROTECTION.....	50
8.5	PROTECTION OF TRANSFORMERS.....	50
8.6	PROTECTION OF ACCUMULATOR BATTERIES.....	51
8.7	PROTECTION OF SIGNAL LAMPS, VOLTMETERS, CAPACITORS AND VOLTAGE COILS IN DEVICES.....	51
8.8	PROTECTION OF POWER SEMICONDUCTOR UNITS.....	51
8.9	PROTECTION ARRANGEMENTS FOR HARMONIC FILTERS.....	51
9	EMERGENCY SOURCE OF ELECTRICAL POWER.....	52
9.1	GENERAL REQUIREMENTS.....	52
9.2	LOCATION OF EMERGENCY SOURCE OF ELECTRICAL POWER AND ASSOCIATED EQUIPMENT.....	52
9.3	EMERGENCY SOURCE OF ELECTRICAL POWER IN CARGO SHIPS.....	53
9.4	DISTRIBUTION OF ELECTRICAL POWER FROM EMERGENCY SOURCE.....	54
9.5	STARTING ARRANGEMENTS FOR EMERGENCY DIESEL GENERATORS.....	54
10	ELECTRICAL ROTATING MACHINES.....	56
10.1	GENERAL.....	56
10.2	SLIP RINGS, COMMUTATORS AND BRUSHES.....	56
10.3	BEARINGS.....	56
10.4	TEMPERATURE TRANSMITTERS.....	56
10.5	OVERLOAD CONDITION.....	56
10.6	ALTERNATING CURRENT GENERATORS.....	57
10.7	DIRECT-CURRENT GENERATORS.....	57
10.8	ELECTROMAGNETIC BRAKES.....	58
11	TRANSFORMERS.....	59
11.1	GENERAL PROVISIONS.....	59
11.2	GENERAL REQUIREMENTS.....	59
11.3	OVERLOAD, VOLTAGE VARIATION AND RUNNING IN PARALLEL.....	59
12	POWER SEMICONDUCTOR UNITS.....	60
12.1	GENERAL REQUIREMENTS.....	60
12.2	PERMISSIBLE PARAMETERS OF VOLTAGE DISTORTION.....	60
12.3	CONTROL AND SIGNALLING SYSTEMS.....	60
13	ACCUMULATOR BATTERIES.....	61
13.1	GENERAL REQUIREMENTS.....	61
13.2	ARRANGEMENT.....	61
13.3	HEATING.....	61
13.4	VENTILATION.....	61
13.5	CHARGING OF BATTERIES.....	61
13.6	INSTALLATION OF ELECTRICAL EQUIPMENT.....	62
13.7	ELECTRICAL STARTING OF INTERNAL COMBUSTION ENGINES.....	62
13.8	SEALED BATTERIES.....	62
13.9	RECORDING OF THE TYPE, LOCATION AND MAINTENANCE CYCLE OF BATTERIES.....	62
14	SWITCHING DEVICES AND INSTALLATION MATERIAL.....	63
14.1	SWITCHING DEVICES.....	63
14.2	ELECTRICAL ACCESSORIES.....	63

15	ELECTRICAL HEATING, AND PREHEATING APPLIANCES.....	65
15.1	GENERAL REQUIREMENTS	65
15.2	HEATING APPLIANCES	65
15.3	OIL AND FUEL PRE-HEATING APPLIANCES	65
16	CABLES AND CONDUCTORS	66
16.1	GENERAL REQUIREMENTS	66
16.2	CONDUCTORS	66
16.3	INSULATING MATERIALS.....	66
16.4	COATINGS	66
16.5	PROTECTIVE SHEATHING	67
16.6	MARKING	67
16.7	CONDUCTOR LAYING	67
16.8	CABLING	67
16.9	CABLE TRAYS AND PROTECTIVE CASINGS MADE OF PLASTICS MATERIALS	76
17	ELECTRICAL PROPULSION PLANT	77
17.1	GENERAL REQUIREMENTS	77
17.2	PERMISSIBLE SUPPLY VOLTAGES	77
17.3	ELECTRICAL MACHINES	77
17.4	SWITCHES IN MAIN AND EXCITATION CIRCUITS	78
17.5	CONTROL OF ELECTRICAL PROPULSION PLANT	78
17.6	ELECTRICAL PROPULSION PLANT WITH SEMICONDUCTOR RECTIFIERS	78
17.7	PROTECTION OF ELECTRICAL PROPULSION PLANTS	79
17.8	ACCESSORIES FOR MEASURING AND SIGNALLING	79
17.9	ELECTRICAL COUPLINGS.....	80
18	ADDITIONAL REQUIREMENTS FOR ELECTRICAL EQUIPMENT DESIGNED FOR VOLTAGES ABOVE 1 kV TO 15 kV	81
18.1	GENERAL.....	81
18.2	SYSTEM DESIGN	81
18.3	ROTATING MACHINERY	82
18.4	POWER TRANSFORMERS.....	82
18.5	CABLES.....	83
18.6	SWITCHGEAR AND CONTROLGEAR ASSEMBLIES	83
18.7	INSTALLATION	83
19	SPECIAL REQUIREMENTS FOR ELECTRICAL EQUIPMENT WITH RESPECT TO SHIP PURPOSE.....	85
19.1	PASSENGER SHIPS.....	85
19.2	OIL TANKERS AND OIL RECOVERY SHIPS	87
19.3	SHIPS INTENDED FOR CARRIAGE OF MOTOR VEHICLES WITH FUEL IN THEIR TANKS, TANK CARS AND TANK WAGONS FOR FLAMMABLE LIQUIDS	91
19.4	SPECIAL PURPOSE SHIPS	92
19.5	CONTAINER SHIPS	92
19.6	CATAMARANS	93
19.7	FLOATING CRANES AND CRANE SHIPS	93
19.8	BULK CARRIERS	93
20	REQUIREMENTS FOR ELECTRICAL EQUIPMENT OF REFRIGERATING PLANTS	95
20.1	GENERAL.....	95
20.2	POWER SUPPLY AND CONTROL	95
20.3	VENTILATION	95
20.4	LIGHTING	95
21	SPARE PARTS	96
21.1	GENERAL REQUIREMENTS	96
21.2	THE QUANTITY OF SPARE PARTS	96

1 GENERAL PROVISIONS

1.1 APPLICATION

1.1.1 This part of the Rules for the classification of ships (hereinafter referred to as: the Rules) applies to electrical equipment in ships subject to supervision of the *CROATIAN REGISTER OF SHIPPING* (hereinafter referred to as: the *Register*) as well as to parts of electrical equipment specified in 1.3.

1.1.2 The relevant requirements of this part of the Rules are recommended to be also extended to shipboard electrical equipment, not particularly specified in 1.3.2 and 1.3.3.

1.1.3 The *Register* retains the right to take into consideration any execution or the mode of installation of electrical equipment, which differs from those required in the present part of these Rules and to approve them, if it appears for sure, that the reliability of the equipment achieved in such way is equal to or higher of the reliability required by this part of the Rules.

1.2 DEFINITIONS AND EXPLANATIONS

Definitions and explanations relating to the general terminology of all the Parts of the Rules are given in the *Rules for the classification of ships, Part 1 - General requirements, Chapter 1 - General*.

For the purpose of this part of the Rules the following definitions have been adopted:

1.2.1 Emergency source of electrical power – is a source of electrical power intended to supply essential consumers on board ship in case the voltage disappears from the busbars of the main switchboard.

1.2.2 Emergency transitional source of electrical power – is a source of electrical power intended to supply essential consumers on board ship from the moment the voltage disappears from the busbars of the main switchboard until the emergency source of electrical power takes the load.

1.2.3 Emergency lighting – is the lighting of ship's compartments and spaces by means of lighting fixtures fed from the emergency source of power or from the transitional source of power.

1.2.4 Safety voltage – is any voltage not dangerous either to crew or passengers. This condition is considered to be satisfied if the windings of transformers, converters and other devices for stepping down voltages are isolated electrically and if the values of the stepped down voltages do not exceed these values:

- 50 V between poles for direct voltage
- 50 V between phases or between phases and the ship's hull for alternating voltage

1.2.5 Essential services – are services where of normal operation ensures continuity of the following functions:

- the propulsion, manoeuvrability, navigation and safety of the ship

- the safety of passengers and crew
- the maintaining and the drives of specific equipment's on ships with a special class notation.

Essential services are subdivided into:

- primary essential services
- secondary essential services

1.2.5.1 Primary Essential Services – are those services which need to be in continuous operation to maintain propulsion and steering

Examples of equipment for primary essential services:

- Steering gears.
- Pumps for controllable pitch propellers.
- Scavenging air blower, fuel oil supply pumps, fuel valve cooling pumps, lubricating oil pumps and cooling water pumps for main and auxiliary engines and turbines necessary for the propulsion.
- Forced draught fans, feed water pumps, water circulating pumps, condensate pumps, oil burning installations, for steam plants on steam turbine ships, and also for auxiliary boilers on ships where steam is used for equipment supplying primary essential services.
- Azimuth thrusts which are the sole means for propulsion/steering with lubricating oil pumps, cooling water pumps.
- Electrical equipment for electric propulsion plant with lubricating oil pumps and cooling wear pumps.
- Electric generators and associated power sources supplying the above equipment.
- Hydraulic pumps supplying the above equipment.
- Viscosity control equipment for heavy fuel oil.
- Control, monitoring and safety devices/systems for equipment to primary essential services.

1.2.5.2 Secondary Essential Services – are those services which need not necessarily be in continuous operation to maintain propulsion and steering but which are necessary for maintaining the safety of the ship passengers and the crew.

Examples of equipment for secondary essential services:

- Windlasses.
- Fuel oil transfer pumps and fuel oil treatment equipment.
- Lubrication oil transfer pumps and lubrication oil treatment equipment.
- Pre-heaters for heavy fuel oil.
- Starting air and control air compressors.
- Bilge, ballast and heeling pumps.
- Fire pumps and other fire extinguishing medium pumps.
- Ventilating fans for engine and boiler rooms.
- Services considered necessary to maintain dangerous spaces in a safe condition.
- Navigational lights, aids and signals.

- Internal Safety Communication Equipment.
- Fire detection and alarm system.
- Main lighting system.
- Electrical equipment for watertight closing appliances.
- Inert gas fans.
- Cargo plan for tankers.
- Cargo cooling plan for refrigeration.
- Control atmosphere system.
- Electric generators and associated power sources supplying the above equipment.
- Hydraulic pumps supplying the above equipment.
- Control, monitoring and safety systems for cargo containment systems.
- Control, monitoring and safety devices/systems for equipment to secondary essential services.

1.2.6 Services for habitability – are those which need to be in operation for maintaining the ship's minimum comfort conditions for the crew.

- Cooking.
- Heating.
- Domestic refrigeration.
- Mechanical ventilation.
- Sanitary and fresh water.
- Electric generators and associated power sources supplying the above equipment.

1.2.7 Special electrical spaces – are spaces or locations intended exclusively for electrical equipment and accessible only to operating personnel.

1.2.8 Low power electrical installation – is an electrical installation of the ship with total installed power of all electrical power sources not exceeding 50 kVA.

Table 1.2.8
Earthing plate

Earthing plate surface	Applicable for earthing		
	Protection	Radio equipment	Lightning equipment
1.0 m	yes	yes	yes
0.5 m	no	yes	yes
0.2 m	no	no	yes

Plate thickness is to be at least 2 mm and the plate may be of two parts provided that the total area exposed to sea water is equal or greater than those specified.

1.2.9 Earthing – is the conductive connection of the metal parts of installation which in normal operation are not under voltage, with the metal parts of the ship having reliable conductive connection to the ship's hull. For the ships having non-conducting hull, the earthing is attained by a separate metal plate, in accordance with the table 1.2.8 fixed to the outer side of shell plating below water line at minimum draught.

1.2.10 Switching equipment – are switchboards and distribution boards, specified as follows:

- .1 Main switchboard (MSB) to which main electrical energy sources are connected.

Harbour generator can be (but not compulsory) connected to MSB.

- .2 Sub-switchboard to which as a rule, are connected power transformers or having a function of main switchboard for only one part of the ship (e.g. for superstructures amidships when machinery space is situated aft). This sub-switchboard is fed directly from MSB.
- .3 Harbour generator switchboard - when harbour generator is not directly connected to MSB but to its own switchboard.
- .4 Refrigerating plant switchboard - is a board from which high power consumers are supplied, i.e. the complete refrigerating installation of ship for carriage of refrigerated cargo.
- .5 Emergency switchboard to which emergency power source is connected feeding emergency circuits.
- .6 Main lighting switchboard - when not forming a part of MSB - serves for feeding all the lighting circuits, except the emergency lighting.
- .7 Distribution boards are cabinets, recesses and lockers with built-in fuses and switches intended for feeding a group of analogous consumers e.g. navigation lights distribution board, cargo and mooring winches distribution board, fore accommodation lighting distribution board etc.

1.2.11 Control switch gear equipment consists of:

- .1 Control and commanding desks intended for commanding and control, as well as for checking the condition of the machinery propulsion system.
- .2 Controllers for starting of a machine which may include also electrical protection of that machine.

1.2.12 Cable network – covers all electrical cables and complete fittings for their regular laying down, i.e. cable trays, supports, glands, distribution and connection boxes, metallic shield earthing etc.

1.2.13 Switch gear – is a common term including all devices for closing and opening electrical circuits:

- .1 Isolating switch is a mechanical switching device having, for the purpose of security, a contact distance in open position according to the regulations. Isolating switch serves principally for disconnecting of the electrical circuit in non-load condition, but under certain conditions (low-voltage, non-inductive load) it could break currents (less than nominal). It can also conduct currents under normal service conditions and for certain short time, conduct short - circuit currents, as well.
- .2 Switch is a mechanical switching device able to connect, stand and disconnect currents under normal service conditions including certain overloads. Switch is operated manually - mechanically.

- .3 Reversing switch - is a switch with two or more switching positions but at least two of them serve for connecting or disconnecting of current - circuits.
- .4 Contractor is a mechanical switching device with power movement. Contractor is able to make, stand and break - currents under normal service conditions under which understanding and certain service overload.
- .5 Circuit breaker is a mechanical device able to work, stand and break currents under normal service conditions. Besides, it is able to work, stand for certain short time and break short-circuit currents.

1.2.14 Lightning conductor protection area – is the area within the limits of which the ship is protected against direct lightning strokes.

1.2.15 Lightning arrested – is the uppermost part of the lightning protective system for conducting the lightning.

1.2.16 Down conductor – is a conductor which electrically connects the lightning arrested to the lightning conductor in accordance with the Table 1.2.8.

1.2.17 Flame - retardant – are materials which burn slowly without supporting fire and without giving off poisonous or aggressive vapours or smoke.

1.2.18 Shaft generators – are generators driven by the propulsion machinery, or by the engines driving the generators of the electrical propulsion plant and supplying the ship's mains or separate consumers.

1.2.19 Explosion - proof electrical equipment – means electrical installations, apparatus and appliances which, when correctly installed and used within limits of their nominal values, will not cause ignition of explosive mixtures of vapours and gases with air.

1.2.20 Dead ship condition - condition under which the main propulsion plant, boilers and auxiliaries are not in operation due to the absence of power.

1.2.21 Black out situation - means that the main and auxiliary machinery installation, including the main power supply, are out of operation but the services for bringing them into operation (e.g. compressed air, starting current from battery etc.) are available.

1.2.22 Control Stations

1. Main navigational equipment includes, in particular, the steering stand and the compass, radar and direction-finding equipment.
2. Steering gear rooms containing an emergency steering position are not considered to be control stations.
3. Where in the regulations of the *Rules for the classification of ships, Part 17 - Fire protection* relevant to fixed fire-extinguishing systems there are no specific requirements for the centralization within a control station of major components of a system, such major components may be

placed in spaces which are not considered to be a control station.

4. Spaces containing, for instance, the following battery sources **shall** be regarded as control stations regardless of battery capacity:
 - .1 emergency batteries in separate battery room for power supply from black-out till start of emergency generator,
 - .2 emergency batteries in separate battery room as reserve source of energy to radiotelegraph installation,
 - .3 batteries for start of emergency generator,
 - .4 and, in general, all emergency batteries required in pursuance of section 9 or section 19.

1.3 SCOPE OF SUPERVISION AND TECHNICAL DOCUMENTATION

1.3.1 General provisions

1.3.1.1 The general provisions applicable to the supervision during construction of ships as well as to survey and classification of ships as well as the requirements referring to technical documentation, which should be submitted to *Register* for inspection or approval, are referred to in the *Rules for the classifications of ships, Part 1 - General requirements*.

1.3.2 Supervision of the ship's electrical installations

1.3.2.1 The equipment, systems and devices are subject to the supervision on board ship, referred to in 1.2.5 and 1.2.6.

1.3.2.2 Electrical equipment intended for domestic, living and technological application (referred to in 1.2.6) shall be supervised on ships only by the *Register* as far as the following items are concerned:

1. effect of its operation to the available electrical power plant on boardship;
2. choice of cables and conductors square area
3. means of protection, insulation and earthing.

1.3.3 Supervision during the manufacture of electrical equipment

1.3.3.1 The following items of electrical equipment referred to in 1.2.5 are subject to supervision during manufacture:

- .1 Electrical generating sets;
- .2 Electrical machines;
- .3 Transformers;
- .4 Switchboards and distribution boards;
- .5 Control and monitoring desks
- .6 Electrical slip couplings and breaks;
- .7 Apparatus and devices for starting, protection, control and commutation

- .8 apparatus and devices for internal communication and signalling;
- .9 Built-in electrical measuring instruments;
- .10 Static power converters and other semiconductor power equipment;
- .11 Heating and cooking electrical appliances;
- .12 Fuel and oil heaters;
- .13 Electrical apparatus and facilities to measure non-electrical values;
- .14 Storage batteries;
- .15 Cables and conductors;
- .16 Built-in accessories;
- .17 Stationary lights;
- .18 Other machinery and facilities not listed above if required by the *Register*.

1.3.3.2 All items referred to in 1.3.3.1, except those in .4 and .5 are subject to type testing under supervision of the *Register* which issues Certificate for type approval of the product. Rules for type approval of products specify the requirements which shall be fulfilled prior to issue such Certificate.

1.3.3.3 Parts of electrical equipment referred to in .1, .2, 3, .4, .5, .6 and .15 of the item 1.3.3.1, in addition to the Certificate referred to in 1.3.3.2, shall be provided with the Certificate for the supervision during manufacture and testing, after satisfactory results of the relevant testing in the presence of a Surveyor to the *Register*.

1.3.3.4 Scope of type testing or electrical equipment shall be agreed with the manufacturer. Technical particulars of testing are referred to in IACS Unified Requirement E10 - Test Specification for Type Approval.

1.3.3.5 All explosion-proof electrical equipment and devices shall be tested for the validity of such design by the authorised institution which shall issue the relevant Certificate. This Certificate does not exclude the supervision and testing referred to in 1.3.3.1, 1.3.3.2 and 1.3.3.3 for all electrical equipment for which they are mandatory.

1.3.4 Technical documentation

1.3.4.1 General provisions for the approval of technical documentation are set forth in the *Rules for the classification of ships, Part 1 - General requirements, Ch. 2 - Survey during construction and initial survey*.

Before starting of the supervision during manufacture of electrical equipment resp. type testing, the following documentation shall be submitted to the *Register* for approval:

- .1 description of the functional scheme;
- .2 functional scheme with main characteristics;
- .3 general view drawing with sectional views;
- .4 list of component parts, instruments and materials of the equipment with their technical characteristics;
- .5 data of dynamic and static electromagnetic interference's resistance;
- .6 measures to be taken for interference suppression;
- .7 testing programme.

Additionally, the following shall be provided:

- .8 for electrical machines above 500 kW, if referred to in 1.3.2, shaft drawing with the data of materials used;
- .9 for electrical machines with rated current in excess of 1000 A: shaft calculation, drawing of pole fastening, active iron core and collector as well as welded joints of shaft and structure;
- .10 for main switchboards with rated current of one generator or the generators operating in parallel in excess of 1000 A: busbar calculation of thermal and dynamical strength.
- .11 for electrical machines with welded parts on shaft:
Shaft drawing with the specification of materials used for shaft and welded parts, as well as data on thermal treatment after welding.

1.3.4.2 For the type approved electrical equipment no documentation need be submitted for approval of supervision acceptance or issue of Certificate.

1.3.4.3 The *Register* may request additional documentation to be submitted, where it proves necessary.

2 CONSTRUCTION OF ELECTRICAL EQUIPMENT

2.1 OPERATING CONDITIONS

The design, choice and arrangement of electrical equipment shall be done with respect to the operating conditions referred to in 2.1.1.

Particulars of type testing of electrical equipment and ambient conditions under which the equipment should operate satisfactorily, are referred to in IACS Unified Requirement - UR E10 - Test Specification for Type Approval.

2.1.1 Effect of operating conditions

2.1.1.1 Tolerances for rated voltage and frequency values under which the equipment shall retain relevant parameters, are specified in the Table 2.1.1-1.

Table 2.1.1-1

Voltage and frequency variations for arc. distribution systems

Quantity in Operation	Variations	
	Permanent	Transient
Frequency	±5%	±10% (5 sec)
Voltage	±6%, -10%	±20% (1.5 sec)

Table 2.1.1-2
Voltage variations for d.c. distribution systems

Parameters	Variations
Voltage tolerance (continuous)	±10%
Voltage cyclic variation deviation	5%
Voltage ripple (a.c. r.m.s. over steady d.c. voltage)	10%

Table 2.1.1-3
Voltage variations for battery systems

Systems	Variations
Components connected to the battery during charging (see Note)	+30%, -25%
Components not connected to the battery during charging	+20%, -25%
Note: Different voltage variations as determined by the charging/discharging characteristics, including ripple voltage from the charging device, may be considered.	

2.1.1.2 Electrical equipment shall be capable of reliable performance at ambient air and cooling water temperatures referred to in the Table 2.1.1.2.

Table 2.1.1.2

No.	Location of equipment	Ambient air and cooling water temperature, °C			
		Unrestricted area of navigation		Restricted area of navigation	
		Air	Water	Air	Water
1	Machinery and, galleys spaces	from + 45° C to 0° C	+ 32	from + 40° C to 0° C	+ 25
2	Weather decks	from + 45° C to - 25° C	-	from + 40° C to - 25° C	-
3	Other spaces and location	from + 40° C to 0° C	-	from + 40° C to 0° C	-
Note: Electronic elements and devices designed for the building in the switchboards, panels or casings shall be capable of reliable operating at ambient temperature up to 55° C. Temperature up to 70° C shall not lead to their damage.					

2.1.1.3 Electrical equipment shall be capable of reliable performance at relative humidity of:

75 ± 3 % at temperature of 45 ± 2°C,

80 ± 3 % at temperature of 40 ± 2°C,

95 ± 3 % at temperature of 25 ± 2°C.

2.1.1.4 Electrical equipment shall be capable of reliable performance with the ship having continuous list up to 15° and trim up to 5° as well as with the ship rolling up to 22,5°, with period of rolling of 10 sec. and pitching up to 10°.

Emergency source of electrical energy shall be capable to supply reliably the ship, having continuous list up

to 22,5°, or trim up to 10°, or in case of simultaneous list and trim.

In ships for the carriage of liquefied gases and of chemicals, the emergency power supply shall also remain operable with the ship flooded to a final athwartships inclination up to a maximum of 30° (see also IACS UI SC6 and IACS UI SC290).

2.1.1.5 Electrical equipment shall be capable of reliable performance under vibrations and shocks referred to in IACS Unified Requirement E10 - Test Specification for Type Approval.

2.1.2 Ambient Temperature for Electrical Equipment in Areas other than the Machinery Spaces

2.1.2.1 Where electrical equipment is installed within environmentally controlled spaces the ambient temperature for which the equipment is to be suitable may be reduced from 45°C and maintained at a value not less than 35°C provided:

- .1 the equipment is not for use for emergency services;
- .2 temperature control is achieved by at least two cooling units so arranged that in the event of loss of one cooling unit, for any reason, the remaining unit(s) is capable of satisfactorily maintaining the design temperature;
- .3 the equipment is able to be initially set to work safely within a 45°C ambient temperature until such a time that the lesser ambient temperature may be achieved; the cooling equipment is to be rated for a 45°C ambient temperature;
- .4 audible and visual alarms are provided, at a continually manned control station, to indicate any malfunction of the cooling units.

2.1.2.2 In accepting a lesser ambient temperature than 45 °C, it is to be ensured that electrical cables for their entire length are adequately rated for the maximum ambient temperature to which they are exposed along their length.

2.1.2.3 The equipment used for cooling and maintaining the lesser ambient temperature is to be classified as a secondary essential service, in accordance with 1.2.5.2.

2.2 ELECTROMAGNETIC COMPATIBILITY

2.2.1 General

Electronic equipment of the ship including radio equipment, navigation aids and automation in order to ensure resistively to electromagnetic interference's shall satisfy requirements of IACS Unified Requirement E10 - Test Specification for Type Approval.

2.2.2 Protection against interference's

2.2.2.1 To ensure protection of radio equipment from interference, the requirements of the SOLAS 74, Chapter IV - Radio communication shall be complied with.

2.2.2.2 Current and voltage impulses generated by closing the mechanical contacts of electrical equipment shall be eliminated or suppressed e.g. by filtering lower frequencies.

2.2.2.3 Where interference affecting an interference - sensitive system cannot be eliminated or suppressed, such systems shall be supplied through galvanically isolated circuit branches or other equivalent measures shall be taken.

2.2.3 Interference transition path

2.2.3.1 Protective screens, metallic cable sheathings and power cable armours shall be earthed as frequently as possible, but at least at connections and at each end to the metal casing of electrical equipment or to the ship's hull.

2.2.3.2 Metallic screens of signal and control cables shall be earthed on one end only. In that case, the earthing shall be performed at the cable input end in equipment.

2.2.3.3 In all cases, continuous conductive connection of all cable sheathings shall be ensured, also within cable branch boxes, cable distribution boxes and cable penetrations.

2.2.3.4 Metal cases of electrical and electronically equipment shall be earthed by means of wide strip conductors or brade which shall be connected directly to ship's hull by shortest possible way. Length of strip or brade shall not exceed 300 mm and the length - to - breadth ratio of earthing connection shall not exceed 5 : 1.

2.2.3.5 Conductors for earthing the cable sheathings and screens shall be star-connected with relevant conductors in one point (e.g. busbars). This point shall be within easy reach and shall not be insulated.

2.2.3.6 All information and signal cables shall be laid at least 200 mm from non - screened power cables or control cables. The parallel laid of cables shall be avoided and cable intersections shall be carried out at right angles.

2.2.3.7 Within switching equipment and control desks, provisions shall be made for the interference protection which corresponds to the conditions of the networking as well as the sensitivity thresholds. Protection by screening, filtration and isolated laying of cables shall be preferable.

2.2.4 Measures to ensure operation of EMI - sensitive equipment

2.2.4.1 Interference suppression in analogue and digital systems is recommended firstly by means of appropriate design and installation. The analogue systems shall be adapted to shipboard conditions regarding their sensitivity threshold, signal level and frequency-dependent ratio. Interference signals in circuits shall be reduced by filter circuits. Digital systems shall comply with the following:

- .1 the static signal threshold shall be as high as practicable with the highest possible signal-interference ratio.
- .2 the switching speed shall be reduced, i.e. functional units shall operate slowly in comparison with the signal decay rates.
- .3 signal power shall be increased to such an extent that interference's cannot cause signal distortion.

2.2.4.2 The metal screens of signal cables shall be insulation - sheathed to prevent possible hull connection.

2.2.4.3 Cables transmitting analogue signals shall be separated from those transmitting digital signals. Parallel laying of cables in the same tray shall be avoided.

Where separate cable laying is impracticable, cables transmitting low - level analogue signals shall be laid in steel pipes or metal trays which shall be together electrically

connected and with the hull. Cables carrying high - voltage or current pulses such as cables of echo - sounding systems shall be laid in metal pipes separately from other cables.

2.2.4.4 Where the measures referred to in 2.2.4.1 to 2.2.4.3 are not effective an optocoupler for optical connection is recommended.

2.2.4.5 When interference's generated by the components of electrical equipment radiate into the space beyond the ship's hull or into supply circuits of radio installation, such component parts shall be protected by the systems which will reduce the interference's across their terminals to the acceptable level or the cable input to radio room shall be effected through the protection filter.

2.2.4.6 The whole cable network laid into the spaces for the ship's radio-communication and radio navigational facilities and on the upper deck and superstructure, if not separated from the aerials by metal deck or bulkhead, shall consist of cables protected by metal shielding lengthways.

2.2.4.7 Metal shielding and enclosures of electrical equipment installed in radio room as well as the shielding of cables and conduction's shall be earthed in accordance with 2.5.3.5. Enclosures and shielding of electrical equipment which do not generate EM-interference's need not be earthed.

2.2.4.8 When electrical equipment and cables are installed in the vicinity of magnetic compasses, requirements of the IMO Resolution A.382(X) shall be taken into account lengthways.

2.2.4.9 Telephone cables and cables of other communication facilities, except cables connecting separate telephone sets, as well as cables of electrical medical equipment which may produce interference's to radio reception, shall be shielded.

2.2.4.10 In all ships constructed from non - conducting materials which are to be mandatory provided with radio equipment in accordance with the Rules, all cables located within a radius of 9 m from the aerial shall be metal shielded or provided with other equivalent protection against radio interference.

2.2.5 Installation of electrical and electronic appliances on the bridge and vicinity of the bridge

2.2.5.1 General

All electrical and electronic appliances installed on the bridge and vicinity of the bridge other than mandatory navigation and communication equipment having been type tested according to IEC 60945:2002, as well as loose equipment placed on board by the builders or owners shall have been EMC tested for Conducted and Radiated Emission. Bridge and vicinity of the bridge covers deck and bridge zone, i.e.

- the wheelhouse including bridge wings
- control rooms, characterized by equipment for inter-communication, signal processing, radio communication and navigation, auxiliary equipment
- area in close proximity to receiving and/or transmitting antennas and large openings in the

metallic structure (equipment beyond 5 meters need not be considered for this purposes).

2.2.5.2 Test standards

The following are acceptable test standards:

- IEC 60945:2002
- IEC 60533:2015

2.2.5.3 Passive-EM equipment

Passive EM equipment defined below, which is excluded from the scope of the EMC since it is considered not liable to cause or be susceptible to disturbances need not to be tested but shall be provided with an exemption statement.

Equipment is considered a passive-EM equipment if, when used as intended (without internal protection measures such as filtering or shielding) and without any user intervention, it does not create or produce any switching or oscillation of current or voltage and is not affected by electromagnetic disturbances.

Example of equipment which include no active electronic part:

- cables and cabling systems, cables accessories.
- equipment containing only resistive loads without any automatic switching device; e.g. simple domestic heaters with no controls, thermostat, or fan.
- batteries and accumulators.

2.2.5.4 Evidence

All electrical and electronic appliances installed on the bridge and vicinity of the bridge other than mandatory navigation and communication equipment having been type tested according to IEC 60945:2002, as well as loose equipment placed on board by the builders or owners shall be listed and be provided with at least the following information. The list and the evidence of equipment are to be kept onboard.

- equipment description
- manufacturer
- type / model
- evidence of EMC compatibility which may be:
 - type approval certificate covering EMC requirements for bridge installations;
 - test certificate or report / conformity statement; or
 - exemption statement.

2.3 MATERIALS

2.3.1 Structural materials

2.3.1.1 The structural parts of electrical equipment shall be manufactured from the durable materials having flame - retardant property resistant to sea and oil vapours or reliably protected against such effects.

2.3.1.2 Chemical composition of the material as well as the mode of protection against effects referred to in 2.3.1.1 are specified in the *Rules for the classification of ships, Part 25 – Metal Materials*.

2.3.1.3 All current - carrying parts of electrical equipment shall be of copper, copper alloys or other equivalent materials with the exception of:

- .1 rheostat elements which shall be made of mechanically strong materials having high specific resistance and temperature withstanding;
- .2 short - circuit rotor windings of asynchronous and synchronous motors which may be made of aluminium or its alloys resistant to sea atmosphere;
- .3 carbon brushes, cermet contacts, slip rings and other similar parts where the properties specified so require;
- .4 parts of electrical equipment directly connected to the ship's hull in case of hull-return single-wire system.

The use of other materials for current carrying parts is subject to special consideration by the *Register*.

2.3.2 Insulation materials

2.3.2.1 Insulating materials for live parts shall have adequate electrical strength and resistance to creepage currents, moisture and oil as well as sufficient mechanical strength or shall be suitably protected.

Temperature of current - carrying parts and their connections shall not exceed permissible heating temperature of the insulating materials at the rated load.

2.3.2.2 Cooling of uninstalled parts of electrical equipment shall be performed by means of non-flammable liquids only.

2.3.2.3 The insulating material used for winding insulation in machines and other essential equipment shall not be inferior to the class E material.

The windings shall be immersed under vacuum conditions into varnish to obtain protective layer. All other technologies other than that shall be subject to the consideration of *Register* in each particular case.

2.3.2.4 Conductors used in electrical devices for internal wiring shall be at least of the material having flame-retardant property, while the parts of equipment exposed to the excessive heating as well as those referred to in Section 15. shall be of non-combustible material.

2.3.2.5 List of insulating materials for cables is set forth in Section 16.

2.4 STRUCTURAL REQUIREMENTS AND DEGREE OF MECHANICAL PROTECTION OF ELECTRICAL EQUIPMENT

2.4.1 General requirements

2.4.1.1 Parts of the equipment which must be replaced while in service, shall be installed in an easily accessible location and shall be easily dismantled.

2.4.1.2 Screws and nuts shall be protected against self-loosening and parts of the equipment which are frequently opened or dismantled shall be well secured in order not to be lost.

2.4.1.3 Gaskets used in components of electrical equipment such as doors, covers sight holes and similar, shall comply with the protection degree of the equipment.

The gaskets shall be secured to the covers or casings by their construction.

2.4.1.4 If casings, covers and protective plates, protecting access to live parts of electrical equipment are installed where unauthorised personnel has free access to them, they shall be removed by special tools only.

2.4.1.5 Component parts of electrical equipment where condensation is likely to occur, shall be provided with water drainage holes. The inside shall be so designed as to ensure the condensate drainage from all the parts.

The windings and live parts shall be so arranged and protected as not to be exposed to the effects of condense.

2.4.1.6 Component parts of electrical equipment with forced ventilation installed in the bottom part of damp spaces shall be so designed, that suction of moisture and oil vapours is minimised.

2.4.1.7 Where the control panels or desks are provided with measuring instruments having oil, steam, water or similar input, provision shall be taken to prevent these agents from coming into contact with live parts in case the instruments and pipelines are damaged.

2.4.2 Insulation clearance and creepage distances

Minimum clearances between parts under different voltage levels or between live parts and earthed metal parts both in air and across the insulating surface, shall correspond to rated voltage and operating conditions of such parts as given in the Table 2.4.2.

Table 2.4.2

System Voltage V	Clearances distances mm				Creepage distances mm	
	J ≤ 63 A		J > 63A		J ≤ 63A	J > 63A
	L-L	L-A	L-L	L-A		
up to 60	2	3	3	5	3	4
61-250	3	5	5	6	4	8
251-380	4	6	6	8	6	10
381-500	6	8	8	10	10	12
501-660	6	8	8	10	12	14
661-750	10	14	10	14	14	20
751-1000	14	20	14	20	20	28

L-L: Between two live parts and between a live part and earthen part.

L-A: Between a live part and a part which can become accidentally dangerous, if live.

For bus-bars and for equipment connected directly to bus-bars in main and emergency switchboards, see Table 4.6.2.10.

2.4.3 Internal wiring

2.4.3.1 Stranded wires shall be used for internal wiring of the electrical equipment throughout. The use of solid wires is subject, in each case, to special consideration of the *Register*.

2.4.3.2 Internal wiring of distribution boards, control desks and similar, shall be performed by means of wires having cross-sectional area not less than 1 mm². For systems of control, protection, measurement, signalling and internal communication, the wires with cross-sectional area not less than 0,5 mm² may be used. For electronically and electrical equipment intended for transformation and transmission of low-power signals, wires of 0,5 mm² may be used on agreement with the *Register*.

2.4.3.3 Current - carrying parts shall be so attached as they are not subjected additionally to mechanical stresses. Such parts shall not be attached by screws fitted directly into insulating material.

2.4.3.4 The ends of stranded cables and conductors shall be prepared depending on the sort of terminals used or shall be provided with cable lugs.

2.4.3.5 Insulated conductors shall be laid up and secured in such a way that the insulation resistance is not reduced and that they are not exposed to damage due to electrodynamic loads, vibrations or shocks.

2.4.3.6 Provisions shall be made to ensure that under normal service conditions and for the duration of short-circuit current, the temperature of the insulated conductors will not exceed the temperature allowed for such conductors.

2.4.3.7 Insulated conductors shall be so connected to terminals or busbars that under normal operating conditions the conductor insulation temperature will not exceed the allowed temperature.

2.4.4 Degree of mechanical protection of parts of electrical equipment

2.4.4.1 Depending on location, parts of electrical equipment shall be made with appropriate protection enclosures to protect equipment from the harmful effect of the environment as well as to protect personnel from electric shock hazards. Technical particularities of enclosures are set forth in the Instructions for type testing, Part 1. Other suitable technological - structural measures may also be taken, but they shall be considered by the *Register* in each particular case.

2.4.4.2 The degree of mechanical protection of the electrical equipment, depending on its location in ship's spaces shall not be lower than those indicated in the Table 2.4.4.2.

Table 2.4.4.2

1	2	3	4	5	6	7	8	9	10	11	12
No.	Space in which electrical equipment is installed	Space characteristics	Degree mechanical protection	Electrical equipment type "x" means in accordance with column 4; "–" means not applicable							
				Switch-boards Control gear	Generators	Motors	Transformers Thyristor	Lighting fixtures	Heating appliances	Cooking appliances	Installation material (switchgear,
1	Ammonia equipment in space	Explosion risk	protection (see 19.2)	–	–	–	–	x	–	–	x
2	Battery room	“		–	–	–	–	x	–	–	x
3	Lamp and paint room	“		–	–	–	–	x	–	–	x
4	Holds with risk of explosion	“		–	–	–	–	x	–	–	x
5	Pipe tunnels for oil and petroleum products with ignition temperature 60°C and below	“		–	–	–	–	x	–	–	x
6	Dry accommodation spaces	Risk of contact with live parts	IP 20	x	–	x	x	x	x	x	x
7	Dry control rooms			x	–	x	x	x	x	x	x
8	Navigating bridge control rooms	Risk of condensate leakage and/or mechanical damage	IP 22	x	–	x	x	x	x	x	x
9	Engine an boilers room above flooring	“	IP 22	x	x	x	x	x	x	x	IP 44
10	Steering gear rooms	“	IP 22	x	x	x	x	x	x	–	IP 44
11	Refrigerating rooms, except for ammonia equipment	“	IP 22	x	–	x	x	x	x	–	IP 44
12	Emergency generator rooms	“	IP 22	x	x	x	x	x	x	–	IP 44
13	General stores	“	IP 22	x	–	x	x	x	x	–	x
14	Pantries	“	IP 22	x	–	x	x	x	x	x	IP 44
15	Provision stores	“	IP 22	x	–	x	x	x	x	–	x
16	Bath rooms and shower rooms	High risk of leakage and/or mechanical damage	IP 34	–	–	–	–	x	IP 44	–	IP 55
17	Engine and boilers room below the flooring		IP 34	–	–	IP 44	–	x	IP 44	–	IP 55
18	Enclosed fuel oil separator rooms		IP 34	IP 44	–	IP 44	–	x	IP 44	–	IP 55
19	Enclosed lub. oil separator rooms		IP 34	IP 44	–	IP 44	–	–	IP 44	–	IP 55
20	Ballast pump rooms	High risk of leakage and mechanical damage	IP 44	x	–	x	x	IP 34	x	–	IP 55
21	Refrigerated spaces		IP 44	–	–	x	–	IP 34	x	–	IP 55
22	Galleys and laundries		IP 44	x	–	x	x	IP 34	x	x	x
23	Shafting tunnels	Spraying risk	IP 55	x	–	x	x	x	x	–	IP 56
24	General stores	Cargo dust Serious mechanical damages. Aggressive vapours	IP 55	–	–	–	–	x	–	–	IP 56

1	2	3	4	5	6	7	8	9	10	11	12
No.	Space in which electrical equipment is installed	Space characteristics	Degree mechanical protection	Electrical equipment type "x" means in accordance with column 4; "-" means not applicable							
				Switch-boards Control gear	Generators	Motors	Transformers Thyristor	Lighting fixtures	Heating appliances	Cooking appliances	Installation material (switchgear,
25	Open decks	Risk of large scale leakage	IP 56	x	-	x	-	IP 55	x	-	x

Note: Where the casing of electrical equipment does not provide for necessary degree of mechanical protection, alternative methods of protection or arrangement of equipment shall be applied to fulfil the requirements in the Table.

2.5 PROTECTIVE EARTHING

2.5.1 Protective earthing of metal parts which do not constitute power distribution system

2.5.1.1 Metal parts of electrical equipment such as enclosures, handles, screens etc. which do not carry current under normal operating conditions but, in case of failure, may become live, shall have a reliable electrical contact to protection earthing and shall be marked with an appropriate symbol. Provision shall be made for earthing inside and outside of the enclosure depending on its purpose.

2.5.1.2 Protection earthing as referred to in 2.5.1, is not required for:

- .1 electrical equipment of rated voltage lower than safety voltage;
- .2 electrical equipment provided with double or reinforced insulation;
- .3 metal parts of electrical equipment fastened in non-conducting material or passing there through so that under normal operating conditions or damage these parts cannot become live;
- .4 housings of specially insulated bearings;
- .5 lamp caps and fasteners for luminescent lamps, lamp shades, reflectors and guards supported on lamp holders or lighting fixtures constructed of or shrouded in non-conducting material;
- .6 cable clips;
- .7 metal parts of individual consumers under rated voltage up to 250 V supplied through an insulating transformer, used exclusively for that consumer;

2.5.1.3 Metal shields against electromagnetic interference and outer metal armour of cables intended for protection against mechanical damage, shall be earthed.

2.5.1.4 The secondary windings of all current and voltage transformers shall be earthed.

2.5.2 Earthing of aluminium structures on steel ships

Superstructures of aluminium alloys fastened to the ship's hull but insulated therefrom, shall be earthed with at least two special conductors each having a cross-sectional area not less than 16 mm² which do not start electrolytic corrosion at their contact with the superstructure and hull. Such earth connections shall be carried out at different locations around superstructure perimeter, shall be accessible for inspection and protected from damage.

2.5.3 Earthing terminals and conductors

2.5.3.1 Bolts for fastening the earth conductor to the hull shall be manufactured of brass or other corrosion-resistant alloy. The bolt diameter shall not be less than 6 mm. Such bolts shall not be used for other purposes. Places of conductor connections to the ship's hull shall be cleaned to metal and properly protected against corrosion.

2.5.3.2 Built-in electrical equipment shall be earthed by means of external conductor or an earthing core in the feeding cable, in the latter case the connection shall be effected inside the enclosure of the electrical equipment. Special earthing need not be provided where the arrangement of equipment ensures a reliable electrical contact between the enclosure and the metal hull of the ship under all operating conditions.

The reliable electrical contact in this case is considered to be a welded contact only. Where earthing is effected by means of external earthing conductor, it shall be made of copper or other corrosion-resistant material provided that its conductivity is at least equal to that of the copper conductor. The cross-sectional area of the copper earthing conductor shall not be less than the values referred to in the Table 2.5.3.2. When one of the cores of the feeding cable is used for earthing, its cross-sectional area shall be equal to the cross-sectional area of the core used for feeding consumers up to 16 mm², at least to one half of cross-sectional area of the feeding core in excess of 16 mm², but in no case lower than 16 mm².

Table 2.5.3.2

Cross-sectional area of feeding cable cores (mm ²)	Minimum cross-sectional area of an external earthing conductor for built-in electrical equipment	
	solid	stranded
Up to 2,5	2,5	1,5
2,5 to 120	Half the cross-sectional area of the feeding cable core, but not less than 4 mm ²	
over 120	70	

2.5.3.3 Portable equipment shall be earthed through an earthing contact in the socket outlet and an earthing core in the portable feeding cable. The cross-sectional area of the earthing core shall comply with the requirements in 2.5.3.2. Supplying voltages and measures which shall be taken for the protection against electric shock when using portable manual tools and lamps shall be in accordance with the Table 2.5.3.3.

2.5.3.4 Special earthing conductors or cores for earthing in the feeding cables of the built-in equipment, shall have no possibility of being disconnected by the switching equipment.

2.5.3.5 Shields and metallic armours shall be earthed in one of the following ways:

- .1 using a copper conductor for earthing, having cross-sectional area not less than 1,5 mm² for cables of cross-sectional area up to 25 mm² and not less than 4,0 mm² for cables with cross-sectional area over 25 mm²;
- .2 by adequate attachment of the shields or metallic armour to the hull or to metallic parts being in conductive connection with the hull.
- .3 by means of cable gland rings provided these rings are of corrosion-resistant material, of good conductivity and elasticity.

Cables shall be earthed at both ends except the end circuit cables in the distribution boxes, which may be earthed at the supply end only. The same is applicable to the cables transmitting low signals, where the earthing of both ends might produce interference's.

2.5.3.6 The external earthing conductors shall be accessible for inspection and protected against getting loose and mechanical damage.

2.5.3.7 Metal armours shall not be used as earthing conductors.

Table 2.5.3.3

No.	Space	Maximum permissible voltage	Remark
1	Narrow spaces with metal walls: double bottom, tanks, receivers boilers, pressure vessels, shaft tunnels.	Safety voltage 12 V	
2	Cargo holds, stores, engine rooms, auxiliary engine rooms, workshops etc., open and sheltered deck.	Safety voltage 50 V	In engine rooms, auxiliary engine rooms and workshops voltage of 24 V is recommended. Voltage of 24 V and of 48 V is recommended in other spaces.
3	Bath rooms (Socket for shaving device).	250 V	Socket shall be earthed through an earthing contact. Socket shall be fitted at the height of 1500 to 1700 mm from the flooring and at the distance of at least 800 mm from the bath. Galvanic separation transformer is recommended.
	Other spaces.	250 V	Provided that the equipment is fitted with double or reinforced insulation or that the enclosure is earthed through separate core of feeding cable being earthed in the socket.
Note: In spaces referred to in 2, the voltage 250 V may be used provided that the galvanic separation transformer feeding one consumer only is used. Both conductors shall be insulated from the hull mass.			

2.5.4 Earthing and bonding of cargo tanks/process plant/piping systems for the control of static electricity

2.5.4.1 The hazard of an incentive discharge due to the build-up of static electricity resulting from the flow of liquids/gases/vapours can be avoided if the resistance between the cargo tanks/process plant/piping systems and the hull of the ship is not greater than 1 MΩ.

2.5.4.2 This value of resistance will be readily achieved without the use of bonding straps where cargo tanks/process plant/piping systems are directly or via their supports, either welded or bolted to the hull of the ship.

2.5.4.3 Bonding straps are required for cargo tanks/process plant/piping systems which are not permanently connected to the hull of the ship, e.g.

- a) independent cargo tanks;

- b) cargo tanks/piping systems which are electrically separated from the hull of the ship;
- c) pipe connections arranged for the removal of spool pieces.
- d) wafer-style valves with non-conductive (e.g. PTFE) gaskets or seals.

2.5.4.4 Where bonding straps are required, they should be:

- a) clearly visible so that any shortcomings can be clearly detected;
- b) designed and sited so that they are protected against mechanical damage and that they are not affected by high resistivity contamination e.g. corrosive products or paint;
- c) easy to install and replace.

2.5.4.5 Checks should be made on the resistance to the hull of the ship during construction of the ship and at subsequent major surveys, supplemented by visual inspection during annual surveys.

2.6 LIGHTNING PROTECTION

2.6.1 General requirements

2.6.1.1 All ships shall be provided with lightning protection equipment which protects all equipment needing such protection. Ships in which lightning strokes may cause a fire or explosion shall be additionally provided with lightning conductors to preclude sparking.

2.6.1.2 A lightning equipment shall consist of a lightning arrested, down conductor and earth termination. Metal masts or other high vertical metallic structures need not be provided with special lightning conductor if they are otherwise reliably electrically connected with the metallic hull or earthing.

2.6.2 Lightning arrested

2.6.2.1 In metallic ships, the ship's vertical structures such as metal masts, derrick ports, superstructures etc. may be used as lightning arrests if provision is made for reliable electrical connection of these structures to the metal hull. Additional arrests shall be fitted only in case such structures do not ensure reliable lightning protection.

2.6.2.2 If electrical device is installed on the top of the metal mast, provision shall be made for an effectively earthed lightning arrested.

2.6.2.3 An effectively earthed lightning arrested shall be fitted on the top of each mast or movable mast prolongation made of non-conducting material.

2.6.2.4 The lightning arrested shall be a rod of at least 12 mm in diameter. The rod shall be made of copper, copper alloy or steel protected against corrosion. For aluminium masts aluminium rods shall be used.

2.6.2.5 The lightning arrested shall extend at least 300 mm above the top of the mast or any device fitted on the top.

2.6.3 Down conductor

2.6.3.1 The down conductor shall be made of a rod, strip or rope having a cross-sectional area not less than 70 mm² for copper or copper alloys or cross-sectional area of at least 100 mm² for steel protected against corrosion.

2.6.3.2 Down conductors shall run lengthwise the outer side of a mast or superstructure with a minimum number of bends having as large as possible radius.

2.6.3.3 Down conductors shall not run through spaces or zones with the explosion hazard.

2.6.3.4 In ships with non-metallic hull the down conductor shall be laid separately throughout its length including connection to the earthing, being entirely separated from the operation and protective earthing circuits.

2.6.4 Earth termination

2.6.4.1 In composite ships the metallic stem or other metallic structures immersed in water under any navigational condition, may be used as earth termination.

2.6.4.2 Provisions shall be made on boardship to connect the ship's metal hull or earth termination to the shore earth termination network when the ship is in a dock or on a slipway.

2.6.5 Connections in lightning equipment

2.6.5.1 Connections between the lightning arrested, down conductor and earthing shall be welded or bolted.

2.6.5.2 The contacting surface area between the lightning arrested and down conductor and earth termination shall not be less than 1000 mm².

The clamps and connecting bolts shall be made of copper, copper alloys or steel protected against corrosion.

2.6.6 Equipment subject to lightning protection

2.6.6.1 Insulated metal structures, portable connections, pipes, metal armour of cables and conductors shall be connected to lightning protection earthing, before entering the hazardous spaces.

2.6.6.2 All pipelines for petroleum products as well as other pipelines associated with hazardous spaces and which are laid on open decks or in spaces without electromagnetic protection shall be earthed to the ship's hull at intervals of at least 10 m. Pipelines which are not connected with hazardous spaces but are laid on the open decks where explosive gases may occur shall be earthed to the ship's hull at intervals of at least 30 m.

2.6.6.3 Metallic parts near down conductors shall be earthed if not fixed to earthed structures or having other metal connection to the ship's hull.

Devices or metal parts located at a distance of up to 200 mm from the down conductor shall be connected to the down conductor, as to prevent sparking.

2.6.6.4 All component parts of the lightning equipment shall be accessible for detecting possible mechanical damage.

2.7 ARRANGEMENT OF ELECTRICAL EQUIPMENT

2.7.1 Electrical equipment shall be so installed as to provide an easy access to controls and to all parts that require maintenance, inspection and replacement.

2.7.2 The horizontal-shaft electrical machines shall be so installed that the shaft is positioned parallel to the centre line of the ship. The installing of these machines with the shaft positioned in another direction is permitted only when the design of the machine ensures its normal operation under conditions referred to in 2.1.

2.7.3 The air-cooled electrical equipment shall be so located that cooling air is not taken under the engine room flooring or other spaces where the air may be contaminated with substances having a harmful effect on insulation.

2.7.4 The electrical equipment built in the locations exposed to vibrations and shocks exceeding the permissible levels (see 2.1.1.5) shall be mounted on shock absorbers or additional constructional modifications shall be made to ensure normal operation under such conditions.

2.7.5 Electrical equipment shall be fixed in such a manner that the elements of attachment do not impair the strength of decks or bulkheads as well as their tightness.

2.7.6 Open live parts of electrical equipment shall be positioned at least 300 mm horizontally and 1200 mm vertically apart from the unprotected non-combustible materials.

2.7.7 When the enclosure of electrical equipment is made of material different from that of the structure on which it is installed, provisions shall be made to prevent electrolytic corrosion, if necessary.

2.8 SPECIAL ELECTRICAL SPACES

2.8.1 The doors of special electrical spaces shall be locked and opened towards outside. In case the doors lead to corridors and passage-ways to accommodation and service spaces, these doors may open inwards providing that protection guards and stops are fitted. Warning notices shall be placed on the doors. The doors from the inside of the spaces shall open without using keys.

2.8.2 Special electrical spaces shall not be adjacent to the tanks with flammable liquids. If this is not practicable due to constructional reasons, provisions shall be made to prevent the penetration of flammable liquids into hazardous areas.

2.8.3 No exits, side scuttles of the removable type or other openings are permitted from special electrical spaces into hazardous areas.

2.8.4 Handrails of non-conducting material shall be installed where the open-type electrical equipment is installed in passageways and servicing areas.

2.9 SAFE-TYPE ELECTRICAL EQUIPMENT

2.9.1 The requirements of the present section apply to the electrical equipment built in the enclosed or semi-enclosed spaces and zones where explosive mixtures of vapours, gas and dust with air are likely to occur.

This category of spaces covers battery compartments, paint rooms and lantern rooms as well as spaces with machinery, piping and tanks for flammable liquids having a flash point of 60°C and below.

Additional requirements for tankers and ships intended for carriage of motor vehicles with fuel in their tanks and tank-wagons with flammable liquids are set forth in the Section 19.

All the electrical equipment installed in hazardous areas before they brought into service should be detailed inspection as defined in standard IEC60079-17:2013 (see IACS Rec. 35 Inspection and Maintenance of Electrical Installation in Hazardous Areas for the Ship other than Tankers).

2.9.2 Hazardous zones

Enclosed or semi-enclosed spaces and zones where the explosion is likely to occur are divided into 3 zones with respect to the category of danger, as follows:

- .1 **Zone 0** - in which an explosive gas/air mixture is continuously present or periodically but then for long time
- .2 **Zone 1** - in which an explosive gas/air mixture is likely to occur only in normal operation, respectively in the course of the technological process
- .3 **Zone 2** - in which the mixtures are not likely to occur and if they occur, they exist for a short time only

2.9.3 The hazardous zones for different ships depending on their purpose have been defined in accordance with the requirements of Section 19.

Division is based on the following criteria:

- .1 Compartments and tanks for flammable liquids having a flash point below 60°C or which are heated to within 15°C of their flash point temperature, are regarded as hazardous zone 0.
- .2 Spaces adjacent to compartments and tanks referred to in .1, spaces adjoining compartments and bottom compartments without forced ventilation are regarded as hazardous zone 0.
- .3 Spaces adjacent to compartments and tanks referred to in .1 which are ventilated during loading/unloading of flammable liquids are regarded as hazardous zone 1.
- .4 Spaces adjacent to compartments and tanks referred to in .1 which are continuously ventilated except when these spaces are in gas free condition are regarded as hazardous zone 1.
- .5 Enclosed and semi-enclosed spaces above pump rooms as well as vertical cofferdams adjacent to compartments and tanks re-

ferred to in .1 are regarded as hazardous zone 2.

- .6 Except unavoidable, access doors or other openings shall not be permitted between:
- .1 non-hazardous and hazardous zones;
 - .2 hazardous zone 2 and hazardous zone 1.

Where such access doors and openings exist, hazardous zones for such spaces are defined as follows:

- non-hazardous zone is regarded the same hazardous category as the space into which the opening leads;
- space of hazardous zone 2 becomes the space of hazardous zone 1.

- .7 Enclosed spaces with direct access to any space of hazardous zone 1 shall be regarded as spaces of hazardous zone 2, provided the following three conditions are fulfilled:

- .1 the access to such spaces is possible only through gas tight doors opening into the spaces of hazardous zone 2;
- .2 the ventilation ensures air circulation through open door from a space of hazardous zone 2 into a space of hazardous zone 1;
- .3 loss of ventilation activates the alarm in a continuously attended watch keeping station

- .8 Enclosed spaces with direct access to spaces of hazardous zone 1 are not regarded as hazardous zones provided the following four conditions are fulfilled:

- .1 the access is possible through double gaslight self-closing doors forming an air lock;
- .2 ventilation in such space generates overpressure towards hazardous zone
- .3 loss of ventilation overpressure activates the alarm in a continuously attended watch keeping station;
- .4 simultaneous break of supply Re-supplying shall be possible only after sufficient ventilating the space in accordance with 2.9.4.

- .9 Enclosed spaces connected with spaces of hazardous zone 2 shall not be regarded as hazardous provided the following four conditions are fulfilled:

- .1 the access is possible only through self-closing gaslight doors, opening into the non-hazardous space;
- .2 circulation of air is ensured through open door from a non - hazardous space into a space of hazardous zone 2;
- .3 loss of ventilation overpressure activates the alarm in a continuously attended watch keeping station;
- .4 simultaneous break of supply.

- .10 A hazardous zone may be extended or reduced depending on additional design arrangements or ventilation systems. Each

particular case regarding such solutions shall be considered by the *Register*.

2.9.4 Ventilation System

- .1 Enclosed hazardous spaces shall be ventilated. In case the forced ventilation is fitted, it shall be such as to ensure lower pressure in the higher category hazardous zones than that in the lower category hazardous zones i.e. non-hazardous spaces are under overpressure in relation to adjacent hazardous spaces.
- .2 Ventilation system shall be sufficient to enable at least 12 air changes per hour.
- .3 Ventilation for hazardous spaces shall be completely separated from that used for non-hazardous spaces.
- .4 Inlet ducts of ventilation system for hazardous spaces shall be located in non-hazardous spaces.
Inlet ducts of ventilation system passing through the higher category hazardous spaces shall have an overpressure in relation to such spaces.
- .5 Pressure piping of ventilation system of hazardous spaces, shall have outlet into a space of the same or lower category of hazardous zone than that of the ventilated space.
- .6 Ventilation system which ensures overpressure in the spaces referred to in preceding items, shall be structurally entirely separate from the ventilation system of the hazardous spaces.
- .7 No devices for keeping self-closing gaslight doors open shall be permitted.

2.9.5 In spaces where explosive mixtures of dust or fibre with air may occur, only electrical equipment with at least IP65 degree of mechanical protection shall be installed.

Where the occurrence of explosive mixture is only temporary resulting from improper sealed equipment or the ventilation cut-off, the electrical equipment with the IP55 degree of mechanical protection may be installed.

- .1 Electrical equipment built in such spaces shall be so designed that the temperature of upper horizontal surfaces or of those inclined at an angle up to 60° to the horizontal is, under conditions of continuous operation 75°C below the smouldering point of dust accumulated in these spaces. The smouldering point is determined for a layer of dust 5 mm thick.

2.9.6 Electrical equipment installed in the hazardous areas and spaces, except fire alarm detectors, shall be provided with the switching device which disconnects all conductors under voltage and which shall be located outside hazardous spaces.

2.9.7 No electrical equipment shall be fastened directly to the walls of tanks with flammable liquids, but at a distance of not less than 75 mm from the tank walls.

2.9.8 Explosion-proof lighting fixtures shall be so installed that a free space around them is not less than 100 mm.

2.9.9 The possibility of the short circuit current flow through the ship's hull in the hazardous areas shall be excluded in the case of alternating current systems with rated voltage of 1000 V up to 15000 V with the earthed neutral.

2.9.10 Only the cables associated with electrical equipment installed in hazardous areas or spaces can be laid in such spaces.

Cable run shall not be permitted through hazardous zone of category O; through hazardous zones 1 and 2 may be permitted provided that the requirements referred to in 2.9.11 to 2.9.16 are fulfilled.

2.9.11 Cables which are laid in hazardous spaces shall be provided with one of the following armours:

- .1 copper armour or stainless steel armour (for cables with mineral insulation);
- .2 non-metallic sheathing with additional mechanical protection for the detecting of earth connection;
- .3 lead armour with additional mechanical protection.

2.9.12 Cables passing through hazardous spaces shall be protected against possible mechanical damage.

- .1 Protective shields and metallic armours of cables intended for feeding electrical motors and lighting network passing through hazardous spaces or supplying electrical equipment in these spaces shall be earthed on both ends;
- .2 Cables which may be affected by corrosion shall be provided with non-metallic protective armour;
- .3 Cables of intrinsically safe circuits may supply only one electrical equipment and shall be laid separately from other cables;
- .4 Cables of portable electrical equipment, except of intrinsically safe network cables, shall not be laid through hazardous spaces.

2.9.13 In spaces adapted for carriage of dangerous cargoes, electrical equipment shall not be installed except if required for service conditions. In such a case the equipment shall be of safe type or provision shall be made for the complete break of supply to that equipment during the carriage of dangerous cargoes by means of separate switch with notice indicating that switching on is forbidden.

2.9.14 Safe type electrical equipment shall be chosen depending on hazardous zones in accordance with the following criteria:

- .1 Electrical equipment with respect to the degree and quality of safe-type execution is subject to the supervision of the authorised organisation, certificates of which *Register* will accept irrespective of whether the equipment is subject to supervision as referred to in 1.3.3 or not.
- .2 In hazardous spaces only electrical equipment of safe-type design corresponding to the temperature class and explosion group mixture of vapours, gases and fibres with air in such spaces, may be installed.

The types shall be:

- .1 intrinsically safe Exi (Exia; Exib);
 - .2 gastight Exd;
 - .3 with increased safety Exe;
 - .4 filled with solid substances Exm;
 - .5 filled with gases (air overpressure) Exp;
 - .6 filled with liquid Exo;
(See Instructions for type testing Part 1. item 3.13).
- .3 No electrical equipment shall be installed in the spaces of hazardous zone 0, except:
- .1 intrinsically safe, temperature and liquid level indicator;
 - .2 cables of intrinsically safe circuits in steel pipes which are not branched - off within the hazardous zone, except if provided with appropriately sealed joints with accessory referred to in the preceding sub-item;
 - .3 echosounder oscillators with associated cables in cofferdams and compartments of double bottom below cargo holds;
 - .4 cables of cathodic forced current protection system for the external hull protection.
- .4 In the hazardous zone 1 the following safe-type electrical equipment may be installed:
- .1 lighting fixtures;
 - .2 telephone apparatus, fire signalling and detecting system, control and monitoring instruments, remote control and communication of intrinsically safe type as well as valves and associated signalling devices;
 - .3 echosounder oscillators in accordance with the performance standard for echo-sounding equipment IMO Resolution A.224(VII), as amended by Resolution MSC.74(69), Annex 4;
 - .4 electric drives for pump rooms fans, provided they comply with the requirements of the *Rules for the classification of ships, Part 7 - Machinery Installation 1.12.6*;
 - .5 electric motors for paint and lantern room fans.
 - .6 Gastight junction boxes or those filled with solid substances (flint sand, solid resins etc.);
 - .7 cables supplying the above-mentioned equipment and devices provided they are laid in steel pipes.
The open installation of cables supplying consumers referred to in sub-items .1 and .2 is permitted provided that on exposed places they are protected with metal covers against possible mechanical damage.
 - .8 provisions shall be made to lay the cables of the intrinsically safe circuits so, that the induction which may occur from other power cables does not in-

duce voltage or energy to such an extent, that the protection of such devices and circuits becomes unsafe.

- .5 In hazardous spaces classified as the hazardous zone 2, electrical equipment referred to in sub. item .4 may be installed as well as the equipment which is not of safe-type but which has no parts generating arc or sparking under normal service conditions or having surface areas being heated in excess of 80°C and with enclosure having the degree of mechanical protection IP 55 or higher.

Installation of such equipment shall be considered by the *Register* in each particular case.

2.9.15 Electrical equipment in paint and lantern rooms

2.9.15.1 In the above-mentioned rooms (Zone 1) and in ventilation ducts supplying and exhausting these areas, electrical equipment must be of certified safe type as give in 2.9.14.2 and comply at least with IIB,T3 (explosion group and temperature class).

Switches, protective devices and motor switch-gear for electrical equipment in these areas must be of all-poles switchable type and shall preferably be fitted in the safe area.

2.9.15.2 On the open deck within a radius of 1 m (Zone 2) around natural ventilation openings (in-and outlets) or within a radius of 3 m around forced-ventilation outlets (Zone 2) the requirements of 2.9.14.5 must be fulfilled. Care must be taken to avoid exceeding temperature class T 3 (200°C).

2.9.15.3 Enclosed areas with access to paint and lantern rooms may be counted as safe areas under the following conditions; if

- the access door to the paint and lantern rooms is gastight and fitted with self-closing devices and without holding back arrangements,
- the paint and lantern rooms are ventilated from a safe area by an independent natural ventilation system,
- warning labels are fixed to the outside of the access door, of paint and lantern rooms drawing attention to the combustible liquids in this room.

2.10 ON BOARD USE AND APPLICATION OF COMPUTER BASED SYSTEMS

2.10.1 Introduction

2.10.1.1 Scopel

These requirements apply to design, construction, commissioning and maintenance of computer based systems where they depend on software for the proper achievement of their functions. The requirements focus on the func-

tionality of the software and on the hardware supporting the software. These requirements apply to the use of computer based systems which provide control, alarm, monitoring, safety or internal communication functions which are subject to classification requirements.

2.10.1.2 Exclusion

Navigation systems required by SOLAS Chapter V, Radio-communication systems required by SOLAS Chapter IV, and vessel loading instrument/stability computer are not in the scope of this requirement.

Note: For loading instrument/stability computer, Rec No. 48 may be considered.

2.10.1.3 References

For the purpose of application of this requirements, the following identified standards can be used for the development of hardware/software of computer based systems. Other industry standards may be considered:

- IEC 61508: Functional safety of electrical/electronic/programmable electronic safety-related systems
- ISO/IEC 12207: Systems and software engineering - Software life cycle processes
- ISO 9001:2008 Quality Management Systems - Requirements
- ISO/IEC 90003: Software engineering - Guidelines for the application of ISO 9001:2008 to computer software
- IEC 60092-504: Electrical installations in ships - Part 504: Special features - Control and instrumentation
- ISO/IEC 25000: Systems and software engineering - Systems and software Quality Requirements and Evaluation (SQuaRE) - Guide to SQuaRE
- ISO/IEC 25041: Systems and software engineering - Systems and software Quality Requirements and Evaluation (SQuaRE) - Evaluation guide for developers, acquirers and independent evaluators
- IEC 61511: Functional safety - Safety instrumented systems for the process industry sector
- ISO/IEC 15288: Systems and software engineering - system life cycle process

2.10.2 Definitions

2.10.2.1 Stakeholders

2.10.2.1.1 Owner

The Owner is responsible for contracting the system integrator and/or suppliers to provide a hardware system including software according to the owner's specification. The Owner could be the Ship Builder Integrator (Builder or Shipyard) during initial construction. After vessel delivery, the owner may delegate some responsibilities to the vessel operating company.

2.10.2.1.2 System integrator

The role of system integrator shall be taken by the yard unless an alternative organisation is specifically

contracted/assigned this responsibility. The system integrator is responsible for the integration of systems and products provided by suppliers into the system invoked by the requirements specified herein and for providing the integrated system. The system integrator may also be responsible for integration of systems in the vessel.

If there are multiple parties performing system integration at any one time a single party is to be responsible for overall system integration and coordinating the integration activities. If there are multiple stages of integration different System Integrators may be responsible for specific stages of integration but a single party is to be responsible for defining and coordinating all of the stages of integration.

2.10.2.1.3 Supplier

The Supplier is any contracted or subcontracted provider of system components or software under the coordination of the System Integrator or Shipyard. The supplier is responsible for providing programmable devices, sub-systems or systems to the system integrator. The supplier provides a description of the software functionality that meets the Owner’s specification, applicable international and national standards, and the requirements specified herein.

2.10.2.2 Objects

The following diagram (Figure 2.10.2.2) shows the hierarchy and relationships of a typical computer based system.

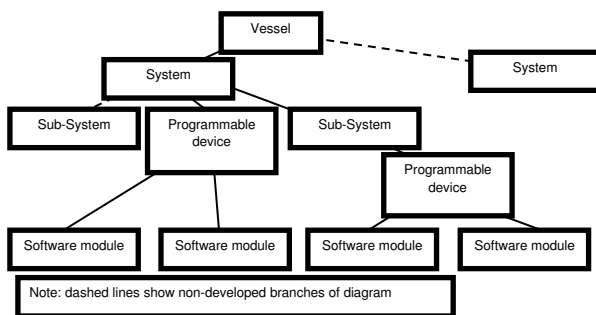

Figure 2.10.2.2 – Illustrative System Hierarchy

2.10.2.2.1 Object definitions

2.10.2.2.1.1 Vessel

Ship or offshore unit where the system is to be installed.

2.10.2.2.1.2 System

Combination of interacting programmable devices and/or sub-systems organized to achieve one or more specified purposes.

2.10.2.2.1.3 Sub-system

Identifiable part of a system, which may perform a specific function or set of functions.

2.10.2.2.1.4 Programmable device

Physical component where software is installed.

2.10.2.2.1.5 Software modul

A module is a standalone piece of code that provides specific and closely coupled functionality.

2.10.2.3 System categories

The following table (Table 2.10.2.3) shows how to assign system categories based on their effects on system functionality.

The following systems typically belong to Category III, the exact category being dependent on the risk assessment for all operational scenarios:

- Propulsion system of a ship, meaning the means to generate and control mechanical thrust in order to move the ship (devices used only during manoeuvring are not in the scope of this requirement such as bow tunnel thrusters)
- Steering system control system
- Electric power system (including power management system)
- Ship safety systems covering fire detection and fighting, flooding detection and fighting, internal communication systems involved in evacuation phases, ship systems involved in operation of life saving appliances equipment
- Dynamic positioning system of equipment classes 2 and 3 according to IMO MSC/Circ.645
- Drilling systems

The following systems typically belong to Category II, the exact category being dependent on the risk assessment for all operational scenarios:

- Liquid cargo transfer control system
- Bilge level detection and associated control of pumps
- Fuel oil treatment system
- Ballast transfer valve remote control system
- Stabilization and ride control systems
- Alarm and monitoring systems for propulsion systems

The example systems are not exhaustive.

Table 2.10.2.3 System categories

Category	Effects	Typical System functionality
I	Those systems, failure of which will not lead to dangerous situations for human safety, safety of the vessel and/or threat to the environment.	- Monitoring function for informational /administrative tasks

Category	Effects	Typical System functionality
II	Those systems, failure of which could eventually lead to dangerous situations for human safety, safety of the vessel and/or threat to the environment.	<ul style="list-style-type: none"> - Alarm and monitoring functions - Control functions which are necessary to maintain the ship in its normal operational and habitable conditions
III	Those systems, failure of which could immediately lead to dangerous situations for human safety, safety of the vessel and/or threat to the environment.	<ul style="list-style-type: none"> - Control functions for maintaining the vessel's propulsion and steering - Vessel safety functions

2.10.2.2.4 Other terminology

2.10.2.2.4.1 Simulation tests

Control system testing where the equipment under control is partly or fully replaced with simulation tools, or where parts of the communication network and lines are replaced with simulation tools.

2.10.3 Requirements for software and supporting hardware

2.10.3.1 Life cycle approach

A global top to bottom approach shall be undertaken regarding software and the integration in a system, spanning the software lifecycle. This approach shall be accomplished according to software development standards as listed herein or other standards recognized by the *Register*.

2.10.3.1.1 Quality system

System integrators and suppliers shall operate a quality system regarding software development and testing and associated hardware such as ISO 9001 taking into account ISO 90003.

Satisfaction of this requirement shall be demonstrated by either:

- The quality system being certified as compliant to the recognized standard by an organisation with accreditation under a national accreditation scheme, or
- The *Register* confirming compliance to the standard through a specific assessment.

This quality system shall include:

2.10.3.1.1.1 Relevant procedures regarding responsibilities, system documentation, configuration management and competent staff.

2.10.3.1.1.2 Relevant procedures regarding software lifecycle and associated hardware:

- Organization set in place for acquisition of related hardware and software from suppliers
- Organization set in place for software code writing and verification
- Organization set in place for system validation before integration in the vessel

2.10.3.1.1.3 Minimum requirements for approval of Quality system:

- Having a specific procedure for verification of software code of Category II and III at the level of systems, sub-systems and programmable devices and modules
- Having check points for the *Register* for Category II and III systems (see Annex for the minimum check points - Examples of check points can be a required submittal of documentation, a test event, a technical design review meeting, or peer review meeting.)
- Having a specific procedure for software modification and installation on board the vessel defining interactions with owners

2.10.3.1.1.4 Quality plan

A document, referred to herein as a Quality Plan, shall be produced that records how the quality management system will be applied for the specific computer based system and that includes, as a minimum, all of material required by paragraphs 2.10.3.1.1.1 to 2.10.3.1.1.3 inclusively.

2.10.3.1.2 Design phase

2.10.3.1.2.1 Risk assessment of system

This step shall be undertaken to determine the risk to the system throughout the lifecycle by identifying and evaluating the hazards associated with each function of the system. A risk assessment report shall upon request be submitted to the *Register*.

This document shall normally be submitted by the System Integrator or the Supplier, including data coming from other suppliers.

IEC/ISO31010 "Risk management - Risk assessment techniques" may be applied in order to determine method of risk assessment. The method of risk assessment shall be agreed by the society.

Based on the risk assessment, a revised system category might need to be agreed between the *Register* and the system supplier.

Where the risks associated with a computer based system are well understood, it is permissible for the risk assessment to be omitted, however in such cases the supplier or the system integrator shall provide a justification for the omission. The justification should give consideration to:

- How the risks are known
- The equivalence of the context of use of the current computer based system and the computer based system initially used to determine the risks

- The adequacy of existing control measures in the current context of use

2.10.3.1.2.2 Code production and testing

The following documentation shall be provided to the *Register* for Category II and III systems:

- Software modules functional description and associated hardware description for programmable devices. This shall be provided by Supplier and System Integrator.
- Evidence of verification (detection and correction of software errors) for software modules, in accordance with the selected software development standard. Evidence requirements of the selected software standard might differ depending on how critical the correct operation of the software is to the function it performs (i.e. IEC 61508 has different requirements depending on SILs, similar approaches are taken by other recognized standard). This shall be supplied by the Supplier and System Integrator.
- Evidence of functional tests for programmable devices at the software module, sub-system, and system level. This shall be supplied by the Supplier via the System Integrator. The functional testing shall be designed to test the provisions of features used by the software but provided by the operating system, function libraries, customized layer of software and any set off parameters.

2.10.3.1.3 Integration testing before installation on board

Intra-system integration testing shall be done between system and sub-system software modules before being integrated on board. The objective is to check that software functions are properly executed, that the software and the hardware it controls interact and function properly together and that software systems react properly in case of failures. Faults are to be simulated as realistically as possible to demonstrate appropriate system fault detection and system response. The results of any required failure analysis are to be observed. Functional and failure testing can be demonstrated by simulation tests.

For Category II and III systems:

- Test programs and procedures for functional tests and failure tests shall be submitted to the *Register*. A FMEA may be requested by the *Register* in order to support containment of failure tests programs.
- Factory acceptance test including functional and failure tests shall be witnessed by *Register*.

Following documentation shall be provided:

- (I) Functional description of software
- (II) List and versions of software installed in system
- (III) User manual including instructions for use during software maintenance
- (IV) List of interfaces between system and other ship systems

- (V) List of standards used for data links
- (VI) Additional documentation as requested by the *Register* which might include an FMEA or equivalent to demonstrate the adequacy of failure test case applied

2.10.3.1.4 Approval of programmable devices for Category II and III systems

Approval of programmable devices integrated inside a system shall be delivered to the system integrator or supplier. Approval can be granted on case by case basis, or as part of a product type approval, so long as above mentioned documents have been reviewed/approved (as per annex) and the required tests have been witnessed by the *Register* (also see 2.10.4 regarding hardware environmental type tests). Documentation should address the compatibility of the programmable device in the ship's application, the necessity to have on board tests during ship integration and should identify the components of system using the approved programmable devices.

2.10.3.1.5 Final integration and on board testing

Simulation tests are to be undertaken before installation, when it is found necessary to check safe interaction with other computerized systems and functions that could not be tested previously.

On board tests shall check that a computer based system in its final environment, integrated with all other systems with which it interacts is:

- Performing functions it was designed for
- Reacting safely in case of failures originated internally or by devices external to the system
- Interacting safely with other systems implemented on board vessel

For final integration and on board testing of Category II and III systems:

- Test specifications shall be submitted to the *Register* for approval
- The tests shall be witnessed by the *Register*

2.10.3.2 Limited approval

Sub-systems and programmable devices may be approved for limited applications with service restrictions by the *Register* when the ship system where they will be integrated is not known. In this case, requirements about Quality systems under 2.10.3.1.1 might need to be fulfilled as required by the *Register*. Additional drawings, details, tests reports and surveys related to the Standard declared by the Supplier may be required by the *Register* upon request.

Sub-systems and programmable devices may in this case be granted with a limited approval mentioning the required checks and tests performed.

2.10.3.3 Modifications during operation

2.10.3.3.1 Responsibilities

Organizations in charge of software modifications shall be clearly declared by Owner to the *Register*. A System integrator shall be designated by the Owner and shall fulfil requirements mentioned in paragraph 2.10.3.1. Limited

life cycle steps may be considered for modifications already considered and accepted in the scope of initial approval. The level of documentation needed to be provided for the modification shall be determined by the *Register*.

At the vessel level, it is the responsibility of Owner to manage traceability of these modifications; the achievement of this responsibility shall be supported by system integrators updating the Software Registry. This Software Registry shall contain:

- List and versions of software installed in systems required in 2.10.3.1.3
- Results of security scans as described in 2.10.3.4

2.10.3.3.2 Change management

The owner shall ensure that necessary procedures for software and hardware change management exist on board, and that any software modification/upgrade are performed according to the procedure. All changes to computer based systems in the operational phase shall be recorded and be traceable.

2.10.3.4 System security

Owner, system integrator and suppliers shall adopt security policies and include these in their quality systems and procedures.

For Category I, II, and III systems, physical and logical security measures shall be in place to prevent unauthorized or unintentional modification of software, whether undertaken at the physical system or remotely.

Prior to installation, all artefacts, software code, executables and the physical medium used for installation on the vessel are to be scanned for viruses and malicious software. Results of the scan are to be documented and kept with the Software Registry.

2.10.4 Requirements for hardware regarding environment

Evidence of environmental type testing according to UR E10 regarding hardware elements included in the system and sub-systems shall be submitted to the *Register* for Category I, II and III computer based systems. This requirement is not mandatory for Category I computer based systems not considered by the *Register*.

2.10.5 Requirements for data links for Category II and III systems

2.10.5.1 General requirements

2.10.5.1.1 Loss of a data link shall be specifically addressed in risk assessment analysis.

2.10.5.1.2 A single failure in data link hardware shall be automatically treated in order to restore proper working of system. For Category III systems a single failure in data link hardware shall not influence the proper working of the system.

2.10.5.1.3 Characteristics of data link shall prevent overloading in any operational condition of system.

2.10.5.1.4 Data link shall be self-checking, detecting failures on the link itself and data communication failures on nodes connected to the link. Detected failures shall initiate an alarm.

2.10.5.2 Specific requirements for wireless data link

2.10.5.2.1 Category III systems shall not use wireless data links unless specifically considered by the *Register* on the basis of an engineering analysis carried out in accordance with an International or National Standard acceptable to the *Register*.

2.10.5.2.2 Other categories of systems may use wireless data links with following requirements:

2.10.5.2.2.1 Recognised international wireless communication system protocols shall be employed, incorporating:

- Message integrity. Fault prevention, detection, diagnosis, and correction so that the received message is not corrupted or altered when compared to the transmitted message.
- Configuration and device authentication. Shall only permit connection of devices that are included in the system design.
- Message encryption. Protection of the confidentiality and or criticality of the data content.
- Security management. Protection of network assets, prevention of unauthorized access to network assets.

2.10.5.2.2.2 The internal wireless system within the vessel shall comply with the radio frequency and power level requirements of International Telecommunication Union and flag state requirements.

Consideration should be given to system operation in the event of port state and local regulations that pertain to the use of radio-frequency transmission prohibiting the operation of a wireless data communication link due to frequency and power level restrictions.

2.10.5.2.2.3 For wireless data communication equipment, tests during harbour and sea trials are to be conducted to demonstrate that radio-frequency transmission does not cause failure of any equipment and does not self-fail as a result of electromagnetic interference during expected operating conditions.

Annex: Documents for the Register and test attendance

A Submitted (for Approval)

I Provided (for Information)

W Witness

¹ Additional documentation may be required upon request² Upon request³ If in the scope of Class requirement

Requirement	SUPPLIER INVOLVED	SYSTEM INTEGRATOR INVOLVED	OWNER INVOLVED	CATEGORY I ¹⁾	CATEGORY II	CATEGORY III
Quality Plan	X	X		A ²	A	A
Risk assessment report		X		I ²	I ²	I ²
Software modules functional description and associated hardware description	X (if necessary)	X			I	I
Evidence of verification of software code	X (if necessary)	X			I	I
Evidence of functional tests for elements included in systems of Category II and III at the level of software module, sub-system and system	X	X			I	I
Test programs and procedures for functional tests and failure tests including a supporting FMEA or equivalent, at the request of the Class Society		X			A	A
Factory acceptance test event including functional and failure tests	X	X			W	W
Test program for simulation tests for final integration		X			A	A
Simulation tests for final integration		X			W	W
Test program for on board tests (includes wireless network testing)		X			A	A
On board integration tests (includes wireless network testing)		X			W	W
- List and versions of software installed in system - Functional description of software - User manual including instructions during software maintenance - List of interfaces between system and other ship systems		X			I	I

Requirement	SUPPLIER INVOLVED	SYSTEM INTEGRATOR INVOLVED	OWNER INVOLVED	CATEGORY I ¹⁾	CATEGORY II	CATEGORY III
Updated Software Registry		X	X		I	I
Procedures and documentation related to Security Policy					I	I
Test reports according to UR E10 requirements	X	X		A ³⁾	A	A

2.11 HARMONIC DISTORTION FOR SHIP ELECTRICAL DISTRIBUTION SYSTEM INCLUDING HARMONIC FILTERS

The calculation results and validity of the guidance provided are to be verified by the surveyor during sea trials.

2.11.1 Scope

The requirements of this Section apply to ships where harmonic filters are installed on main busbars of electrical distribution system, other than those installed for single application frequency drives such as pump motors.

2.11.2 General

The total harmonic distortion (THD) of electrical distribution systems is not to exceed 8%.

This limit may be exceeded where all installed equipment and systems have been designed for a higher specified limit and this relaxation on limits is documented (harmonic distortion calculation report) and made available on board as a reference for the surveyor at each periodical survey.

2.11.3 Monitoring of harmonic distortion levels for a ship including harmonic filters

The ships are to be fitted with facilities to continuously monitor the levels of harmonic distortion experienced on the main busbar as well as alerting the crew should the level of harmonic distortion exceed the acceptable limits. Where the engine room is provided with automation systems, this reading should be logged electronically, otherwise it is to be recorded in the engine log book for future inspection by the surveyor.

2.11.4 Mitigation of the effects of harmonic filter failure on a ship's operation

Where the electrical distribution system on board a ship includes harmonic filters the system integrator of the distribution system is to show, by calculation, the effect of a failure of a harmonic filter on the level of harmonic distortion experienced.

The system integrator of the distribution system is to provide the ship owner with guidance documenting permitted modes of operation of the electrical distribution system while maintaining harmonic distortion levels within acceptable limits during normal operation as well as following the failure of any combination of harmonic filters.

3 MAIN ELECTRICAL POWER SOURCES

3.1 NUMBER AND POWER OF ELECTRICAL SOURCES

3.1.1 In every ship of 300 GT and above, a main electrical power source shall be provided the power of which is sufficient to supply the electrical equipment on board referred in items 1.2.5 and 1.2.6. Such a source shall consist of two independently driven generators at least.

3.1.2 For cargo ships area of navigation 4, 5, 6, 7 and 8 less than 300 GT and passenger ships area of navigation 5, 6, 7 and 8 length less than 30 meters, with low power electrical installation, it is permitted that main electrical power source can be accumulator batteries with capacity 3 hours without recharging for supply electrical equipment referred to in 3.1.3.1 and generator or alternator with capacity for supply the electrical equipment referred to 3.1.3.1.

Where the generator or the alternator driven by the propulsion engine ship speed change or change in direction of the propeller shaft rotation must not interrupt power to any of the equipment referred to 3.1.3.1.

3.1.3 The number and the power of independently driven generators and electrical transducers, if they constitute a part of the main source of electrical power, shall be such that, if any of them failed, the remaining power is sufficient for:

- .1 supplying the essential consumers under conditions referred to in 1.2.5 simultaneously assuring life conditions referred to in 1.2.6, except of those are to be considered:
 1. Thrust's not forming part of the main propulsion
 2. Mooring
 3. Cargo handling gear
 4. Cargo pumps
- .2 starting the most powerful electrical motor with the greatest starting current and the longest starting time what shall not cause a voltage and frequency drop in the mains that could result in a fall of generator out of synchronism, stop of generator prime mover or disconnection from mains of motors and apparatus being in operation;
- .3 supplying the consumers necessary to start the propulsion plant with the ship completely de-energised. For this purpose, emergency electrical power source may be used, if its own power or its power combined with the power of any other electrical source, is sufficient to ensure a simultaneous supply of consumers referred to in 9.3.1 to 9.3.3 or 19.1.2.1 (see also the *Rules for the classification of ships, Part 7 - Machinery Installations*, 1.4.7).

3.1.4 Generators driven from the propulsion plant may be accepted as generators forming the main source of electrical power if in all sailing and manoeuvring condition, includ-

ing the propeller being stopped, the arrangement is such that the generating capacity of these generators is sufficient to provide the electrical power to comply with 3.1.3. They shall be not less effective and reliable than the independent generating sets.

3.1.5 Where the main source of electrical power is necessary for propulsion and steering of the ship, the system shall be so arranged that the electrical supply to equipment necessary for propulsion and steering and to ensure safety of the ship will be maintained or immediately restored in the case of loss of one generators in service.

3.1.6 Where the electrical power is normally supplied by more than one generator set simultaneously in parallel operation, provision of protection, including automatic disconnection of sufficient non-essential services and if necessary secondary essential services and those provided for habitability, should be made to ensure that, in case of loss of any of these generating sets, the remaining ones are kept in operation to permit propulsion and steering and to ensure safety.

3.1.7 Where the electrical power is normally supplied by one generator provision shall be made, upon loss of power, for automatic starting and connecting that the main switchboard of stand-by generator(s) of sufficient capacity with automatic restarting of the essential auxiliaries, in sequential operation if required. Starting and connection to the main switchboard of one generator should be as rapid as possible, preferably with 30 seconds after loss of power.

Where prime movers with longer starting time are used, this starting and connection time may be exceeded upon approval from the *Register*.

3.1.8 Load shedding or other equivalent arrangements shall be provided to protect the generators against sustained overload.

- .1 The load shedding should be automatic.
- .2 The non-essential services, service for habitable conditions may be shed and where necessary, additionally the secondary essential services, sufficient to ensure the connected generator set(s) is/are not overloaded.

3.1.9 Secondary essential services may be included in automatic load shedding or other equivalent arrangement provided disconnecting will not:

- a) cause immediate disruption of systems required for safety, e.g.:
 - Lighting system,
 - Navigation lights, aids and signals,
 - Internal safety communication equipment.
- b) Prevent services required for safety being immediately available when the power supply is restored to normal operating conditions, e.g.:
 - Fire pumps, and other extinguishing medium pumps,
 - Bilge pumps,
 - Ventilation fans for engine and boiler room.

3.1.10 Examples of equipment of secondary essential consumers for which the automatic load shedding or other equivalent arrangement is allowed, includes:

- Fuel oil transfer pumps and fuel oil treatment equipment,
- Lubricating oil transfer pumps and lubricating oil treatment equipment,
- Pre-heaters for heavy fuel oil,
- Starting air and control air compressors (except for control air compressors for propulsion control and safety systems),
- Services listed in 3.1.3.1.1 to 3.1.3.1.5.

3.1.11 The main generator station is to be situated within the machinery space, i.e. within the extreme main transverse watertight bulkheads.

Any bulkhead between the extreme main transverse watertight bulkheads is not regarded as separating the equipment in the main generating station provided that there is access between the spaces.

3.1.12 The main switchboard is to be located as close as practicable to the main generating station, within the same machinery space and the same vertical and horizontal A 60 fire boundaries.

3.1.13 Where essential services for steering and propulsion are supplied from section boards these and any transformers, converters and similar appliances constituting an essential part of electrical supply system is also satisfied with 3.1.12.

3.2 ELECTRICAL GENERATING SETS

3.2.1 General requirements

3.2.1.1 Engines intended for generator prime movers shall comply with the requirements of the *Rules for the classification of ships, Part 9 - Machines*, Section 2 and 3 respectively as well as with additional requirements of this section.

3.2.1.2 Generator prime movers shall be provided for continuous duty under operating conditions referred to in the Table 2.1.1.2.

3.2.1.3 Permanent short circuit current of a generating set under short circuit condition in network shall be sufficient high to selectively activate protective devices.

3.2.1.4 The voltage regulation of generators shall be in compliance with the requirements of 10.6 and 10.7. of the present part of the Rules and their frequency control in compliance with the requirements of the *Rules for the classification of ships, Part 9. - Machines*, 2.11.3.

3.2.1.5 For alternating current generators, the deviation of voltage no-load curve from sine voltage curve shall not be more than 5% of the first harmonic peak value.

3.2.2 Load sharing between sets running in parallel

3.2.2.1 Regarding the speed of rotation, prime mover regulators used to drive alternating current generators provided to operate in parallel, shall comply with the following requirements:

- .1 the operating load of every generating set within 20 to 100% of the rated load, shall

not differ from the value proportional to its power output in relation to power output of all generating sets operating in parallel by more than 15% of the rated working load of the largest generating set in parallel or by not more than 25% of the rated working load of the relevant generating set, whichever of the values is higher;

- .2 the above load sharing shall be ensured without manual regulation of prime mover voltage or speed of rotation;
- .3 devices shall be provided for the precise regulation of load variation within 5% of rated power at rated frequency;

3.2.2.2 Alternating current generating sets intended to run in parallel shall be provided with a reactive voltage drop compensating system, which ensures, that the sharing of reactive load, on each generator when operating in parallel, does not differ from the value proportional to their rated powers for more than 20% of rated reactive load of the largest generator or not more than 25% of rated reactive load of the smallest generator if this value is less than the previous one.

3.2.2.3 When alternating-current generators operate in parallel within 20-100% of the rated load, the permissible current oscillations shall be within $\pm 15\%$ of the rated current of the largest generator.

3.2.2.4 Regarding the speed of rotation, prime mover regulators used to drive direct-current generators provided to operate in parallel, shall comply with the following requirements:

- .1 the load sharing to each of the generators in parallel shall be proportional to their individual rated powers.
- .2 within 20-100% or the rated load of each generator, the power shall not differ more than 12% of the rated power of the largest generator, or 20% of rated power of the smallest generator operating in parallel.

If generators are of equal power, the load on generators operating in parallel shall not differ from a value proportional to their power by more than 10% of their rated power.

3.2.3 Shaft driven generator systems

3.2.3.1 Generators and generator systems, having the ship's main propulsion machinery as their prime mover, may be accepted as part of the ship's main source of electrical power, provided:

- .1 They are to be capable of operating under all weather conditions during sailing and during manoeuvring, also when the vessel is stopped, within the specified limits for the voltage variation and the frequency variation in 2.1.1.1.
- .2 Their rated capacity is safeguarded during all operations given under .1, and is such that in the event of any other one of the generators failing, the services given under 3.1.3 can be maintained.
- .3 The short circuit current of the generator/generator system is sufficient to trip the

generator/generator system circuit-breaker taking into account the selectivity of the protective devices for the distribution system.

Protection is to be arranged in order to safeguard the generator/generator system in case of a short circuit in the main bus bar. The generator/generator system is to be suitable for further use after fault clearance.

- .4 Standby sets are started in compliance with the item 3.1.7.

3.2.3.2 Generators and generator systems, having the ship's main propulsion machinery as their prime mover, but not forming part of the ship's main source of electrical power may be used whilst the ship is at sea to supply electrical services required for normal operational and habitable conditions provided that:

- .1 There are sufficient and adequately rated additional generators fitted, which constitute the main source of electrical power required by 3.1.1.
- .2 Arrangements are fitted to automatically start one or more of the generators, constituting the main source of electrical power required by 3.1.1, in compliance with 3.1.7 and also upon the frequency variations exceeding $\pm 10\%$ of the limits specified below.
- .3 Within the declared operating range of the generators and/or generator systems the specified limits for the voltage variations and the frequency variations in 2.1.1.1 can be met.
- .4 The short circuit current of the generator and/or generator system is sufficient to trip the generator/generator system circuit-breaker taking into account the selectivity of the protective devices for the distribution system.
- .5 Where considered appropriate, load shedding arrangements are fitted to meet the requirements of 3.1.8.
- .6 On ships having remote control of the ship's propulsion machinery from the navigating bridge means are provided, or procedures be in place, so as to ensure that supplies to essential services are maintained during manoeuvring conditions in order to avoid a blackout situation.

3.2.4 Exhaust-gas turbogenerators

3.2.4.1 Turbogenerators used for ship's mains supply as the main electrical power source, driven by exhaust gases shall be provided with devices for voltage regulation in compliance with 10.6 and 10.7 of the present part of the Rules and for regulation of frequency in compliance with the *Rules for the classification of ships, Part 9. - Machines*, 2.11.3.

3.2.4.2 Turbogenerators supplying particular consumers may, if agreed with the *Register*, depart from the requirements referred to in 3.2.4.1.

3.2.4.3 Turbogenerators referred to in 3.2.4.1 shall be capable of operating in parallel with independently driven generators in compliance with 3.2.2.

3.3 NUMBER AND POWER OF TRANSFORMERS

3.3.1 In ships, where lighting and other essential consumers are supplied through transformers, at least two transformers shall be provided of such an individual power that in case of failure of one transformer, the remaining one is capable of satisfying the complete need in electrical power of ship under all operating conditions in compliance with 3.1.4.

3.3.2 Where subdivided system of busbars is used, transformers shall be connected to different bus-bar sections.

3.3.3 Each transformer required is to be located as a separate unit with separate enclosure of equivalent, and is to be served by separate circuits on the primary and secondary sides. Each primary circuit is to be provided with switch-gear and protection devices in each phase.

Each of the secondary circuits is to be provided with a multipole isolating switch.

Transformers supplying bow thruster are excluded.

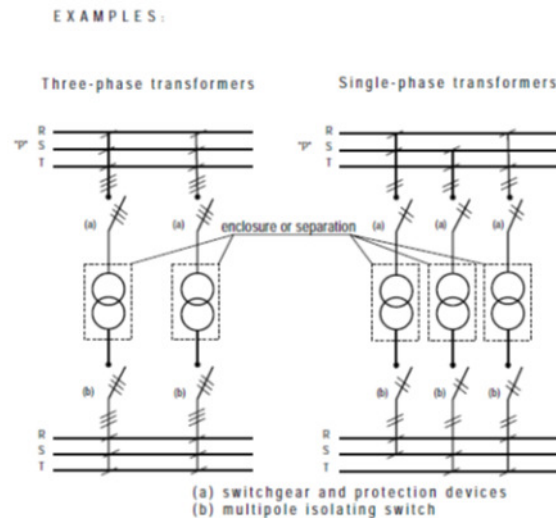

3.3.4 In ships of restricted area of navigation 5, 6, 7, 8 as well as in ships of restricted area of navigation 3, 4 (other than passenger ships) with the low power electrical equipment (50 kVA), the use of only one transformer is permitted.

3.4 POWER SUPPLY FROM EXTERNAL SOURCE OF ELECTRICAL POWER

3.4.1 If provision is made for ship's network to be supplied from an external source of electrical power, a separate switchboard shall be installed in the ship. In ships with the low power electrical installation (up to 50 kVA) the cables for

supply are permitted to be connected directly to the main switchboard.

3.4.2 In the external supply switchboard provisions shall be made for:

- .1 terminals for flexible cable connections;
- .2 switching and protection devices for permanently laid cable to the main switchboard. Where the cable length between the external supply switchboard and the main switchboard is less than 10 m, no protection devices are necessary;
- .3 voltmeter with change-over switch or pilot lamp to indicate the presence of voltage on terminals;
- .4 device to control polarity or phase sequence;
- .5 terminal for earthing a neutral wire from external source;
- .6 plate to indicate voltage, kind of current, frequency and distribution system;
- .7 arrangement for the mechanical fixing of the end of flexible cable connected to the switchboard as well as a cable hanger

3.5 CONNECTIONS OF ELECTRICAL POWER SUPPLY SOURCES

3.5.1 Where the electrical power sources are not provided for the parallel operation on common busbars, it is necessary to apply such a connection which ensures parallel operating during load transfer from one source to another.

3.5.2 Direct current compound - wound generators shall be provided with equalising connections.

3.5.3 Where alternating current generators are provided to operate in parallel, synchronising devices shall be installed in the main switchboard.

Where synchronising operates automatically, manual synchronising shall be provided in addition.

Irrespective of the sychroscope for manual or automatic synchronising, the lamps for manual synchronising shall be additionally installed.

3.5.4 Where several direct current generators are installed as the main source of electrical power, a magnetising device shall be fitted in the main switchboard.

Such device may also be fitted for alternating - current generators, if it appears necessary for initial excitation.

3.5.5 Where the ship's and external sources of electrical power are not intended to operate in parallel on the common busbars, switching devices shall be so interlocked as to prevent such parallel operating.

4 DISTRIBUTION OF ELECTRICAL POWER

4.1 DISTRIBUTION SYSTEMS

4.1.1 The following systems of electrical power distribution shall be allowed for the ship's network:

- .1 three - phase alternating current systems up to 1000 V;
 - .1 three - wire insulated system;
 - .2 three - wire system with neutral earthed;
- .2 additionally for alternating current systems up to 500 V;
 - .1 three - phase, four - wire system with neutral earthed, without hull return;
 - .2 single - phase, two - wire insulated system;
 - .3 single - phase, two - wire system with one wire earthed;
- .3 direct current systems;
 - .1 two - wire insulated system;
 - .2 single - wire with hull return for voltages up to 50 V, under following conditions:
 - in ships up to 1600 GT, inclusively
 - in ships over 1600 tons gross tonnage but only for locally restricted earthed systems such as starters of internal combustion engines. This item does not apply to tankers.
 - .3 two - wire system with one pole earthed,
 - .4 three - wire system with middle wire earthed.

The use of other systems is subject to special consideration by the *Register* in each particular case.

4.2 PERMISSIBLE VOLTAGES

4.2.1 The maximum permissible voltage at the terminals of electrical power source with frequencies of 50 and 60 Hz is referred to in 4.1.1. depending on the distribution system. Additional requirements for voltages of 1000 to 11000 V are listed in the Section 18.

4.2.2 The maximum permissible voltage at the terminals of direct current source shall not exceed the values listed below:

- 500 V for power systems;
- 250 V for lighting and heating systems as well as for socket outlets.

4.2.3 The maximum permissible voltage at the terminals of alternating - current consumers shall not exceed the values specified in the Table 4.2.3.

Table 4.2.3

No.	Consumers	Permissible voltage, V
1	2	3
1	Permanently installed power consumers and cooking and heating appliances, in all spaces other than those referred to in item 2	1000
2	Portable power consumers supplied from socket outlets by means of flexible cables, fixed in position when used, such as: <ul style="list-style-type: none"> – heaters and melters, installed in accommodation spaces (see 15.2.5) – control circuits 	500
3	Lighting, signalling and internal communication devices, socket outlets for portable consumers with double or reinforced insulation or supplied through transformers with galvanically separated windings	250
4	Socket outlets fitted in spaces with increased humidity or those with extra humidity in compliance with the Table 2.4.4.2 for the supply of consumers without protective insulation or protective galvanic separation (see item 3)	50

4.2.4 The maximum permissible voltage at the terminals of direct-current consumers shall not exceed the values specified in the Table 4.2.4.

Table 4.2.4

No.	Consumers	Permissible voltage, (V)
1	2	3
1	Permanently installed and supplied power consumers	500
2	Heating devices, lighting, socket outlets exceeding safe voltage provided in spaces with increased humidity or extra humid spaces in compliance with table 2.4.4.2 shall be provided with warning plates allowing the connection of consumers only with protective insulation or galvanically separated	250

4.3 POWER SUPPLY OF ESSENTIAL CONSUMERS

4.3.1 The following consumers shall be supplied by separate feeders from the main switchboard busbars:

- .1 Steering gear electrical drives (see 5.5.2),
- .2 anchor gear electrical drives (see 4.3.3),
- .3 fire pump electrical drives,
- .4 bilge pump electrical drives,

- .5 electric drives of compressors and sprinkler system pumps
- .6 gyrocompass,
- .7 refrigerating plant distribution board for cargo holds;
- .8 electrical drives of exciter sets for electrical propulsion plant,
- .9 Control atmosphere system.
- .10 main lighting switchboard,
- .11 radio station distribution board
- .12 navigational equipment distribution board
- .13 navigational and signalling lights distribution board
- .14 distribution board for supplying other essential consumers combined on the principle of similarity either requirements or function
- .15 switchgears of bridge control console (see 4.5),
- .16 distribution board of automatic fire detection and alarm system,
- .17 electrical drives of propulsion machines
- .18 distribution boards of electrical drives for cargo and mooring winches, davit equipment and other gears, ventilation and heating appliances;
- .19 control device of controllable pitch propeller;
- .20 charging facilities of starter accumulator batteries for internal combustion engines and batteries supplying essential consumers;
- .21 distribution board of electrical drives for closing watertight doors and devices holding fire protective doors in the open position, as well as distribution boards of signalling system indicating position and closure of watertight and fire-protective doors.
- .22 distribution board of refrigerating plant for the low pressure carbon dioxide extinguishing system;
- .23 lighting distribution board for hangars and helicopter deck illumination;
- .24 other machinery and installations, at the request of *Register*,

It is permitted to supply consumers referred to in .4, .6, .10, .11, .12, .15, .16, .18 and .20 above from distribution boards referred to in .13 and .14 by separate feeders provided with appropriate switching and protective devices.

4.3.2 In case that two or more same-purpose machinery's or installations with electrical drives referred to in 4.3.1 are installed, except those referred to in 4.3.1.1, 4.3.1.5 and 4.3.1.8, at least one of these shall be supplied by a separate feeder from the main switchboard. Electrical drives of the rest of machinery may be supplied from distribution board or special switching devices intended for the supply of essential consumers. When the main switchboard busbars are divided into sections having intersectional switching device, the electrical drives, distribution boards and special switching devices installed in double number or more, or supplied by two feeders, shall be connected to different busbars sections.

4.3.3 In cargo ships of restricted area of navigation 3, 4, 5, 6, 7, 8 and exceptionally in ships of unrestricted area of navigation or area of navigation 1, 2, the supply feeder of anchor gear may be connected to the distribution board of cargo winches or to another distribution board, on special approval of the *Register*, provided that the boards are supplied directly from the main switchboard and that they are equipped with the adequate protection.

4.3.4 Final circuits with rated current exceeding 16 A may supply only one consumer.

4.4 POWER SUPPLY OF ELECTRICAL AUTOMATION SYSTEMS

4.4.1 Power supply of electrical automation systems shall meet the requirements of the *Rules for the classification of ships, Part 13 - Automation*.

4.4.2 Automation devices necessary for starting and operating the emergency generator shall be supplied from a starting battery or another independent accumulator battery installed in the emergency generator room.

4.5 POWER SUPPLY OF SHIP CONTROL CONSOLES

4.5.1 When the electrical equipment, navigational equipment, radio equipment, automatic and remote-control electrical equipment for the main and auxiliary machinery are built in the bridge control console, such equipment shall be supplied by separate feeders in accordance with the present section and other Sections of this part of the Rules. The consumers listed in 4.3.1 may be fed from the distribution board built in the bridge control console provided the requirements of 4.5.2 to 4.5.6 are fulfilled (see 9.4.3 also).

4.5.2 Distribution boards in the bridge control console shall be fed directly from the main switchboard or through transformers by two independent feeders connected to different sections of the busbars if such a busbar system is available.

When the emergency generator is provided on board, the distribution boards in the bridge control console shall be supplied by one feeder from the main switchboard and by the other feeder from the emergency switchboard.

4.5.3 The distribution boards in the bridge control console shall be independently supplied by a separate feeder from the other source of electrical power, if it appears necessary, with regard to the requirements posed on the equipment supplied from these boards.

4.5.4 Feeders for distribution boards referred to in 4.5.2 shall be provided with a change-over switch. If an automatic change - over is provided, provision shall be also made for manual switching with necessary interlocking.

4.5.5 Each consumer referred to in 4.3.1 which is fed from the distribution board in the bridge control console shall be supplied by a separate feeder.

4.5.6 A light signalling device indicating the presence of voltage shall be fitted in the bridge control console.

4.6 SWITCHING EQUIPMENT

4.6.1 Construction

4.6.1.1 Frames, front panels and enclosures of the main and emergency switchboards as well as distribution boards shall be constructed of metal or other rigid, durable, non-combustible material.

Generator fields in main switchboard shall be divided by the non-combustible bulkheads vertically to the busbar system.

The same bulkheads shall be fitted under the busbar system lengthwise.

4.6.1.2 Switchboards shall be of sufficient strength, to withstand mechanical stresses under service conditions as well as the stresses resulting from the short circuit conditions.

4.6.1.3 Switchboards shall be at least protected against drip. This protection is not required when the switchboards are fitted in spaces where no vertical water drops may enter into them (see 4.6.6.2)

4.6.1.4 Distribution boards fitted in the places accessible to unauthorised persons shall be provided with doors to be opened by special key which is the same for all distribution boards in the ship.

4.6.1.5 The doors of the distribution boards shall be so designed as to ensure the access to all parts which need maintenance and live parts of the device located on the doors shall be protected against inadvertent touching.

Doors and withdrawable frames which are used for mounting switching devices and instruments for voltage greater than 50 V shall be securely earthed with at least one flexible braide.

4.6.1.6 Handrails shall be fitted to the switchboards, distribution boards and control consoles on their front sides. Switchboards and distribution boards which are accessible from the rear shall be provided with the horizontal handrails fitted at the back. The materials which may be used for handrails are wood, insulating material or earthed metal pipes with insulating covering.

4.6.1.7 The generator-fields of main switchboard shall be illuminated with lighting fixtures supplied from the generator side before the generator circuit breaker or at least from two different busbar sections in case these sections are provided in accordance with 3.5.6.

4.6.1.8 The front side of the switchboard panels shall be so illuminated as not to produce blinding effect.

4.6.1.9 The switchboards and distribution boards which have no free space left at the rear, shall be so designed as to ensure the access to all parts which require maintenance. The doors shall be so arranged as to be fixed in the open position. Blocks and accessories which may be lifted or withdrawn, shall be fitted with blocking devices to prevent their fall-out from the withdrawn or lifted position.

4.6.1.10 In plants where the main source of electrical power is necessary for the propulsion of the ship disconnecting switches shall be provided in the main switchboard to divide busbars into sections. Disconnection can be achieved by

circuit breakers without tripping mechanism, disconnecting links or switches by which busbars can be split easily and safely.

Bolted links, for example bolted bus bar sections, are not acceptable.

Generators and consumers shall be symmetrically connected to busbar section.

4.6.2 Busbars and uninstalled connections

4.6.2.1 The maximum permissible temperature for busbars and uninstalled connections of switching devices at the rated load and short - circuit condition or at the permissible one second short - circuit load of copper busbars, shall be determined according to IEC recommendations in agreement with the *Register*.

4.6.2.2 Equalising busbars shall be designed for at least 50 percent of the rated current of the largest generator connected to the main switchboard.

4.6.2.3 Where the busbars are in contact with or close to insulated parts, their heat effects under operating or short-circuit conditions shall not cause temperature rise in excess of permissible for that insulation material.

4.6.2.4 Busbars and uninstalled connections in the switchboard shall be provided with so mechanical and thermic strength that can stand flow of short-circuit current happened in the net.

Electrodynamics forces which appeared in busbars and uninstalled connections due the short-circuit shall be determined according to standards in agreement with the *Register*.

4.6.2.5 Insulators and other insulating elements designed to support busbars and uninstalled conductors shall be capable to sustain forces due to short circuit.

4.6.2.6 The natural vibration frequency of copper busbars shall be outside the ranges of 40 to 60 Hz and 90 to 110 Hz for rated frequency of 50 Hz and outside of 50 to 70 Hz and 110 - 130 Hz for rated frequency of 60 Hz.

4.6.2.7 Busbars and uninstalled conductors of different polarities in direct current distribution system shall be marked with the following distinguishing colours:

- .1 red - positive pole;
- .2 blue - negative pole;
- .3 black or yellow - green, earth connection;
- .4 grey - middle wire.

Equalising conductor shall be marked with poll colour and additional with white transversal stripes.

4.6.2.8 Busbars and uninstalled conductors of different phases in alternating current distribution systems, shall be marked with the following distinguishing colours:

- .1 yellow - phase 1;
- .2 green - phase 2;
- .3 violet - phase 3;
- .4 grey - neutral wire;
- .5 green - yellow (transverse stripes) - earth connections.

4.6.2.9 Busbar joints shall be made so as to prevent corrosion at the connection areas.

4.6.2.10 For bare bus bars and uninstalled connections the minimum clearance and creepage distances between live parts and between live parts and earthed parts are to be as given in the table: 4.6.2.10.

Table 4.6.2.10

Nominal voltage of the system, V	Minimum clearance distance mm	Minimum creepage distance, mm
up to 250	15	20
251-660	20	30
661-1000	25	35

4.6.3 Selection of switchgear and calculation of short - circuit currents

4.6.3.1 Switchgear shall be so selected that under normal operating conditions their voltages, loads and temperature rise limits are not exceeded. The gear shall also be capable of withstanding without damages or exceeding permissible temperature limits, loads expected in transient conditions. Short - circuit protection devices shall comply at least with the standards taking into account the short - circuit power factor in the alternating current systems, as well as the values of initial and transient short - circuit currents.

4.6.3.2 The rated breaking capacity of the short - circuit current breakers shall not be less than that of the maximum prospective short - circuit current at the point of their installation at the moment of breaking.

4.6.3.3 The rated making capacity of circuit breakers which may be switched on during short circuit shall be at least equal to that of the maximum prospective short - circuit current at the point of the installation.

4.6.3.4 The rated dynamic strength of the breakers which are not intended for breaking short - circuit currents shall not be less than the maximum prospective short - circuit current at the point of the installation.

4.6.3.5 The rated thermal strength of the switching devices shall be in accordance with the maximum prospective short - circuit current at the point of their installation as well as with the expected duration of short circuit due to the selectivity of the protection.

4.6.3.6 The circuit breakers without adequate breaking and/or making capacities which correspond to the maximum prospective short-circuit current, shall be permitted only, provided, that they are protected on the generator side by means of fuses or circuit breakers, having necessary ratings for short-circuit currents but which are not used as generator circuit breakers.

Switching protective devices thus composed, shall comply with the following requirements:

- .1 while breaking the maximum prospective short-circuit current, the circuit breaker on the consumer side shall not be so damaged as to become unfit for further service
- .2 switching on the circuit breaker on the maximum prospective short - circuit cur-

rent shall not result in damage to any part of the device, although the circuit breaker is allowed not to be immediately fit for further operation on the consumer side.

4.6.3.7 A circuit breaker shall be fitted for overload protection in circuits with a current rating up to 320 A and over. The circuit breakers are recommended already for the currents exceeding 200 A.

4.6.3.8 Circuit breakers for compound generators intended for parallel operation, shall have a common pole for connection of the equalising conductor, mated mechanically with the other poles of circuit breaker so as to switch on busbars prior to other poles and switch off after their disconnection from the busbars.

4.6.3.9 The short circuit current shall be calculated on the basis of the IEC recommendations approved by the *Register*.

4.6.3.10 In the calculation of the expected prospective short-circuit current the equivalent impedance of the system on the fault side is to be taken into account. All generators which may be connected in parallel and all electrical motors running simultaneously, shall be taken into calculation. Current from the generators and electrical motors shall be calculated on the basis of their characteristics.

When precise information is lacking, the following effective values shall be taken as the electrical motors alternating current sources:

- at the initiation of the short - circuit $6,25 I_n$
- at the T moment after short-circuit $2,5 I_n$,
- at the 2 T moment after short circuit $1,0 I_n$,
- maximum peak value $8,0 I_n$,

where:

I_n is equal to the sum of rated currents of all the electric motors

For the direct current systems, the maximum short-circuit current value shall be determined so that the contribution of the electrical motors is taken to be equal to six-fold sum of the rated currents of the electric motors running simultaneously. The calculation shall be made for all cases of the short-circuit currents being characteristic for the system in question.

The following cases of the short-circuit currents shall be taken into account:

- on the generator side;
- on the main switchboard busbars;
- on the emergency switchboard busbars;
- on the consumers and distribution boards supplied directly from the main switchboards.

The minimum short-circuit current is determined in order to define overcorrect circuit breaker tripping.

The calculation of the short-circuit current shall contain the list of all selected switching devices with their characteristics as well as the value of short-circuit currents at the points of their installation.

4.6.4 Arrangement of switching devices and measuring accessories

4.6.4.1 Switching devices as well as measuring and control accessories used in connection with generators and other large essential consumers shall be installed in the switchboard fields associated with the appropriate generators and consumers.

This requirement may be dispensed with if the central control console is fitted with switching devices and measuring accessories for several generators.

4.6.4.2 An amperemeter and a voltmeter shall be provided for each direct-current generator on the main and emergency switchboard.

4.6.4.3 Each alternating current generator on the main switchboard and each emergency generator on the emergency switchboard shall be provided with the following instruments:

- .1 amperemeter with a change-over switch (for current measurement in each phase);
- .2 voltmeter with a change-over switch (for measuring phase or line voltage);
- .3 frequency meter (use of one double frequency meter is permissible for generators operating in parallel with changeover switch to each generator);
- .4 wattmeter (for output upwards of 50 kVA);
- .5 other accessories as required.

4.6.4.4 In ships having a low power electrical installation (up to 50 KVA) in which generators are not expected to operate in parallel, only one set referred to in 4.6.4.2 and 4.6.4.3 may be installed at the main and emergency switchboard enabling measurements on each generator installed.

4.6.4.5 Amperemeters shall be installed in the circuits of essential consumers rated at 20 A and over. These amperemeters may be installed on the main switchboard or at the control console.

One amperemeter with change-over switch may be installed, but for not more than six consumers.

4.6.4.6 For the connection of the external power source, the main switchboard shall be provided with:

- .1 switching device;
- .2 protective device;
- .3 measuring accessories
- .4 means for the control of phase sequence.

4.6.4.7 For each insulated distribution system a device for measuring insulation resistance shall be installed on the main and emergency switchboard. The use of one device with the appropriate change-over switch may be applied. The hull leakage current necessary for the operation of the measuring device shall not exceed 30 mA.

Provision shall be made for visual and audible alarms to warn of inadmissible decrease of the insulation resistance.

In ships with unattended machinery spaces such a signalling shall be provided at the ship's main control station.

4.6.4.8 Measuring instruments shall have measuring ranges in excess of the rated values to be measured as follows:

- .1 voltmeters: 120 per cent of the rated voltage;
- .2 amperemeters for generators not operating in parallel and for consumers: 130 per cent of the rated current;
- .3 amperemeters for generators operating in parallel:
 - for load current: 130 per cent of rated current;
 - for reverse current (reefers only to direct-current generators): 15 per cent of rated current;
- .4 wattmeter's for generators not operating in parallel: 130 per cent of rated power;
- .5 wattmeter's for generators operating in parallel:
 - power: 130 percent of the rated power,
 - reverse power: 15 per cent of the rated power;
- .6 frequency meters: ± 10 per cent of the rated frequency

The specified measuring ranges may be changed on agreement with the *Register*.

4.6.4.9 Rated voltages, currents and power ratings of electrical propulsion plant and generators shall be clearly indicated on the scales of electrical measuring instruments.

4.6.4.10 Circuit breakers shall be installed and connected to busbars in such a way that, when they are in open position, none of the movable contacts and protective or control devices associated with switches, are under voltage.

4.6.4.11 When circuit breakers and fuses are installed in the switchboard, the fuses shall be positioned between busbars and switches. The same pattern is applicable to other switching devices.

4.6.4.12 The fuses in switchboards and distribution boards installed on the foundation at the floor level shall be located not lower than 150 mm or higher than 800 mm from the floor level.

Live open parts of switchboards shall be located at least 150 mm above the floor level.

4.6.4.13 Fuses shall be so installed in switchboards and distribution boards that they are easily accessible and that the cartridge replacement is not dangerous for the operating personnel.

4.6.4.14 Screwed-in fuses shall be so installed that the supply leads are connected to the lower terminal.

4.6.4.15 The fuses protecting the poles or phases of the same circuit shall be installed in a row, horizontally or vertically, depending on the fuse design. The fuses in the alternating current circuit shall be positioned to follow the sequence of phases i.e. from left to right or from top to bottom.

In direct current circuits, the positive-pole fuses shall be fitted on the right at the top, or closest possible to the service man.

4.6.4.16 Manual voltage regulators on the main switchboard and emergency switchboard shall be positioned close to the measuring instruments associated with the particular generator.

4.6.4.17 Ampermeters of compound generators intended for operation in parallel shall be installed in the circuit of that pole, which is not connected to the equalising conductor.

4.6.4.18 For connecting portable or semi-portable tools, flexible-stranded conductors shall be used.

4.6.4.19 Device controls, measuring accessories, switchboards, panels and outgoing circuits shall be provided with inscriptions. The switching position of the switchgear shall also be indicated.

Besides the rated currents of the fuses as well as the current settings of the circuit breakers, the trippings of other switching devices shall also be marked.

4.6.4.20 Each outgoing circuit in a switchboard shall be provided with appropriate switch, switching on simultaneously all unearthed conductors.

Switches need not be provided for the following circuits:

- lighting distribution board provided with main switch,
- interlocking device,
- alarms and signals,
- local lighting of distribution boards, if protected by melting fuses (see 8.1.4.)

4.6.5 Light signalling

4.6.5.1 Light signalling shall be of the colour specified in the Table 4.6.5.1.

Table 4.6.5.1

No.	Colour	Meaning	Type of signal	Explanation
1	2	3	4	5
1	Red	Danger	Blinking	Alarm in dangerous conditions where immediate action is required.
			Permanent	General alarm in dangerous conditions. Dangerous condition detected but not yet eliminated.
2	Yellow	Attention	Blinking	Abnormal service condition where immediate action is not required.
			Permanent	Intermediate condition between abnormality and safety. Abnormal condition already detected, but not yet rectified.
3	Green	Safety	Blinking	Standby machinery in operation
			Permanent	Normal service condition. Engines in operation
4	Blue	Information	Permanent	Machinery ready to be started. Voltage on mains. Everything in order.
5	White	General Information	Permanent	Information signals activated when necessary. Notations relating to automatic control conditions. Other additional information.

4.6.7 Access to switchboards

4.6.7.1 In front of the main switchboard a passageway shall be provided at least 0,8 m wide for switchboards up to 3 m long and 1,0 m wide for those exceeding 3 m. In ships of less than 500 tons gross tonnage the width of the passageway may be reduced to 0,6 m.

4.6.5.2 Provisions shall be made to ensure testing of light sources and associated circuits of the light signals.

4.6.6 Arrangement of switching devices

4.6.6.1 The main switchboards and distribution boards having open live parts on the rear side, installed lengthwise the ship's side below load waterline, shall be protected from water by special metal shields or by means of any other equivalent structural measure.

4.6.6.2 The switching devices shall be installed in the locations where concentration of gases, dust, water, vapours and acid evaporations is excluded.

4.6.6.3 Special spaces, cabinets or recesses with switching devices having protective enclosures of IP10 degree or below, shall be made of non-combustible material or at least shall have linings of such material.

4.6.6.4 Pipelines and tanks near the switching devices shall be arranged in accordance with the *Rules for the classification of ships, Part 8 - Piping*, 1.6.5.

4.6.6.5 The navigation light distribution board shall be located in the navigating bridge. It shall be visible and readily accessible to the personnel on watch.

4.6.6.6 Main switchboard and generators shall be positioned in the same vertical fire zone.

4.6.7.2 Behind the free standing switchboards, it is necessary to provide a passageway at least 0,6 m wide for switchboards up to 3,0 m in length and not less than 0,8 m for longer switchboards.

Between the free standing switchboards with open live parts located in special electrical spaces, a passageway shall not be less than 1,0 m.

4.6.7.3 The passageway behind the free standing switchboards with open live parts shall be enclosed and fitted with doors. The doors shall be of the type in accordance with 2.8.1.

4.6.7.4 For switchboards exceeding 3,0 m in length and referred to in 4.6.7.3., at least two doors shall be provided leading from the space where the switchboard is installed to the space behind the switchboard. The doors shall be as widely spaced as possible.

One of these doors may lead to the adjacent space having at least one more exit.

4.6.7.5 Passageways referred to in 4.6.7.1 and 4.6.7.2 are measured from the most protruding parts of devices and structures of switchboards to the protruding parts of equipment or hull structural parts.

5 ELECTRICAL DRIVES FOR SHIP MECHANISMS AND EQUIPMENT

5.1 GENERAL

5.1.1 The control consoles of the drives shall comply with the requirements of the *Rules for the classification of ships, Part 7 - Machinery Installations*, while the power supply of electrical and electronically automation systems shall comply with the requirements of the *Rules for the classification of ships, Part 13 - Automation*.

5.1.2 Electrically driven machinery shall be provided with light signals indicating switching on/off of the electrical drive.

5.1.3 Equipment with automatic, remote and manual control shall be so designed that the automatic control as well as remote control is simultaneously switched off in case of change-over to the manual control, which shall be independent both of the automatic and remote control.

5.2 INTERLOCKING OF MACHINERY OPERATION

5.2.1 The machinery provided with electrical and manual drives shall be fitted with an interlocking device that will prevent simultaneous operation of both drives.

5.2.2 If the machinery is required to operate in a certain sequence, appropriate interlocking device shall be used. Technical documentation of such devices shall be subject to special consideration of the *Register* in each particular case.

5.2.3 Provision may be made to switch - off the interlocking device on condition that the device is protected against inadvertent switching - off.

The inscription with warning to indicate its application and forbid its use by unauthorised personnel shall be placed in close vicinity. Such a device shall not be permitted for the machinery referred to in 5.2.1.

5.2.4 Starting of the machinery, devices and installations which require additional ventilation in normal operation, shall be possible only after ventilation is activated.

5.3 SAFETY TRIPPING DEVICES

5.3.1 Control systems of machinery and equipment whose operation under certain conditions may endanger safety of ship or crew, shall be provided with push - buttons or other safety tripping devices that will ensure instantaneous switching-off the electrical drive. These push-buttons and/or other devices shall be in red and suitably protected against inadvertent actuation.

The inscription indicating its application shall be placed in close vicinity.

5.3.2 Push-buttons or other safety tripping devices shall be located near the control consoles or other places enabling safe action.

5.3.3 Electrical drives of machinery and equipment which require restriction of motion to prevent damage or break down, shall be provided with end switches to ensure reliable switching off of the electrical motor.

5.4 DEVICES FOR STARTING, REVERSING AND REGULATION

5.4.1 The devices for starting, reversing and regulation in current circuit of electrical drives, which are not provided as short-circuit protection devices, shall be so designed to stand prospective short-circuit current in time necessary that the protective device released.

5.4.2 Devices for starting and regulation shall ensure the starting of electrical motor only from zero position.

5.4.3 Devices for starting and regulation which ensure isolation of the shunt-field winding, shall be provided with a discharge protection device.

5.4.4 For the directly started alternating - current electrical motors the requirements of 3.1.2.2 and 16.8.3.3 shall be complied with.

5.4.5 For each alternating current motor exceeding safe voltage in accordance with 1.2.4 as for its devices for switching and regulation, provision shall be made to switching off power supply. If these devices are fitted in the main switchboard or in other distribution board in the same compartment and its visibility is ensured from the place of installation of the electrical motor, a switch mounted in the switchboard or distribution board may be used for this purpose.

In case that the requirement with respect to the location of devices is not complied with, provision shall be made for:

- 1 a device for blocking devices for starting and regulation, installed in the switchboard or distribution board, in the off position, or
- 2 an additional disconnecting switch near the electrical motor, or
- 3 fuses in each pole or phase arranged so that they could be easily removed or replaced again.

5.5 ELECTRICAL DRIVE AND CONTROL OF STEERING GEAR

5.5.1 In addition to the requirements of the present part of the Rules, steering gear shall comply with the requirements of the *Rules for the classification of ships, Part 9 - Machines*, 6.2 and the *Rules for the classification of ships, Part 3 - Hull Equipment*, 2.

5.5.2 Main electrical or electrical - hydraulically steering gear comprising one or more power units shall be supplied by two separate feeders connected directly to the main switchboard through separate cable runs (see 16.8.4.13).

When the busbars in the main switchboard are subdivided, each feeder shall be supplied from different sec-

tions (see 4.3.2). One of these circuits may be supplied from the emergency switchboard.

If the steering gear is provided with the auxiliary electrical or electro - hydraulically power unit (in compliance with the *Rules for the classification of ships, Part 9 – Machines*, 6.2), it may be supplied directly from the main switchboard.

5.5.3 Each feeder shall be designed to supply all the electrical motors connected thereto and operating simultaneously.

5.5.4 If a change-over switch is provided to supply electrical motor from one or the other feeder, such feeders shall be designed for operation under the maximum load. The change-over switch shall be installed in the steering gear compartment.

5.5.5 In case of failure of the electrical or electro-hydraulic power unit in operation, another power unit in accordance with the *Rules for the classification of ships, Part 9 – Machines*, 6.2 shall be actuated automatically or manually from the bridge control console.

5.5.6 In every ship provided with the steering gear in accordance with the *Rules for the classification of ships, Part 9 – Machines*, 6.2, provision shall be made for the automatic switchover in the event of failure of the main source of electrical power within 45 seconds. The power supply shall be switched over to the emergency source of electrical power or other independent source located in the steering gear compartment and intended only for that purpose.

For ships of 10.000 GT and over the power of that independent source is required to be sufficient for continuous supply of the steering gear, remote control of the system and rudder angle indicator for at least 30 min. and for other ships for at least 10 min.

5.5.7 The operating conditions of the electrical motors of the drives for the active means of the ship's steering, shall conform to the conditions required for the complete gear, but the motors shall in any case satisfy the short - term duty of at least 30 min.

5.5.8 The electrical or electrohydraulic drive of a steering gear shall ensure:

- .1 putting the rudder from hard to hard over, within the time and angle referred to in the *Rules for the classification of ships, Part 9 – Machines*, 6.2;
- .2 putting the rudder continuously from hard to hard over, during 30 min. for each power unit separately, at the maximum service speed ahead and the draught at which the rudder is fully immersed.
- .3 continuous putting over during one hour at the maximum service speed ahead with an angle so as to ensure 350 putting over per hour;
- .4 stopping of the electrical motor in "on" position for one minute from hot state (only for rudders fitted with the direct electrical drive);
- .5 sufficient power of electrical drive in relation to the forces arising at maximum speed astern. It is recommended to provide

for the possibility for putting the rudder over at the average speed astern.

5.5.9 Starting and stopping steering gear electrical motors drives shall be possible from the steering gear compartment and the wheelhouse.

5.5.10 The starting device shall ensure automatic re-starting of an electrical motor as soon as the voltage is restored after a break in power supply.

5.5.11 In the bridge and main machinery control station, audible and visual alarms shall be provided in the event of:

- .1 voltage loss, phase break-off or power circuit overload, for each propulsion machinery
- .2 voltage loss in the power circuits of the control system,
- .3 minimum permissible oil level in the filling-up tanks of the hydraulic system
- .4 state of electrical motor of the power unit,

5.5.12 The steering gear control system in compliance with the *Rules for the classification of ships, Part 9 – Machines*, 6.2, shall be supplied from the power circuit of the steering gear electrical drive in the steering gear compartment or directly from the busbars of the switchboard supplying this power circuit.

5.5.13 In the steering gear compartment, means shall be provided for disconnecting any bridge control system from the steering gear it serves.

5.5.14 Each control system in compliance with the *Rules for the classification of ships, Part 9 – Machines*, 6.2, shall be provided with its own independent circuit for transmission of orders to the steering gear actuator.

5.5.15 The direction of rotation of the rudder wheel or the movement of the control gear handle shall correspond to the direction of the rudder blade rotation.

In case of push-button control system, the push-buttons shall be arranged so that the switching on of the push-button located to the right, causes the rudder blade to move rightward, while the button on the left its motion leftward.

5.5.16 It is permitted to install automatic pilots which control the steering gear by means of their own signal transmission system or by means of the manual system of steering gear drive as well as adaptable automatic pilots.

5.5.17 The automatic pilot control systems shall be of a completely self-synchronising type and shall require no adjustment during the switching - over from one mode of operation to another.

5.5.18 The control desk may be provided with a steering wheel, handle or push-buttons as controlling means.

5.5.19 Switching from automatic control to manual control shall be effected by one movement in not more than 3 sec. irrespective of the rudder position.

5.5.20 All essential circuits in the control desk shall be protected against short circuit by means of fuses or automatic circuit breakers.

5.5.21 The control desk shall be provided with the regulable lighting of the repeater card and the steering blade angle indicator.

5.5.22 Electrical independency of steering gear control systems and failure detection and response of all types of steering gear control systems

5.5.22.1 Separation of Control Systems and Components

5.5.22.1.1 General

Wires, terminals and the components for duplicated steering gear control systems installed in units, control boxes, switchboards or bridge consoles shall be separated as far as practicable.

Where physical separation is not practicable, separation may be achieved by means of a fire retardant plate.

5.5.22.1.2 Steering wheel or steering lever

All electric components of the steering gear control systems shall be duplicated. This does not require duplication of the steering wheel or steering lever.

5.5.22.1.3 Steering mode selector switch

If a joint steering mode selector switch (uniaxial switch) is employed for both steering gear control systems, the connections for the circuits of the control systems shall be divided accordingly and separated from each other by an isolating plate or by air gap.

5.5.22.1.4 Follow-up amplifier

In the case of double follow-up control (see example 2), the amplifiers shall be designed and fed so as to be electrically and mechanically separated. In the case of non-follow-up control and follow-up control, it shall be ensured that the follow-up amplifiers are protected selectively (see example 3).

5.5.22.1.5 Additional control systems

Control circuits for additional control systems, e.g. steering lever or autopilot shall be designed for all - pole disconnection (see examples 1, 2 and 3).

5.5.22.1.6 Feed-back units and limit switches

The feed-back units and limit switches, if any, for the steering gear control systems shall be separated electrically and mechanically connected to the rudder stock or actuator separately.

5.5.22.2 Failure detection and response of all types of steering gear control systems

5.5.22.2.1 Failure detection

5.5.22.2.1.1 The most probable failures that may cause reduced or erroneous system performance shall be detected and at least the following failure scenarios shall be considered:

- a) Power supply failure
- b) Earth fault on AC and DC circuits
- c) Loop failures in closed loop systems, both command and feedback loops (normally short circuit, broken connections and earth faults)
- d) Data communication errors
- e) Programmable system failures (Hardware and software failures)
- f) Deviation between rudder order and feedback (Deviation alarm shall be initiated if the rudder's actual position does not reach the set point within acceptable time limits for the closed loop control systems (e.g. follow-up control and autopilot). Deviation alarm may be caused by mechanical, hydraulic or electrical failures.)

5.5.22.2.1.2 All failures detected shall initiate an audible and visual alarm on the navigation bridge.

5.5.22.2.2 System response upon failure

5.5.22.2.2.1 The failures (as defined but not limited to those in 5.5.22.2.1.1) likely to cause uncontrolled movements of rudder are to be clearly identified. In the event of detection of such failure, the rudder is to stop in the current position without manual intervention or, subject to the discretion of the *Register*, is to return to the midship/neutral position.

For mechanical failures such as sticking valves and failure of static components (pipes, cylinders), the system response without manual intervention is not mandatory, and the operator can follow instructions on the signboard in case of such failures, in accordance with the *Rules for the classification of ships, Part 9 – Machines, 6.2.10.11*.

For hydraulic locking failure, refer also to the *Rules for the classification of ships, Part 9 – Machines, 6.2.10.10.2 and 6.2.10.11*.

5.5.22.3 Examples

Reference should be made to examples 1, 2 and 3, which can be regarded as basic design.

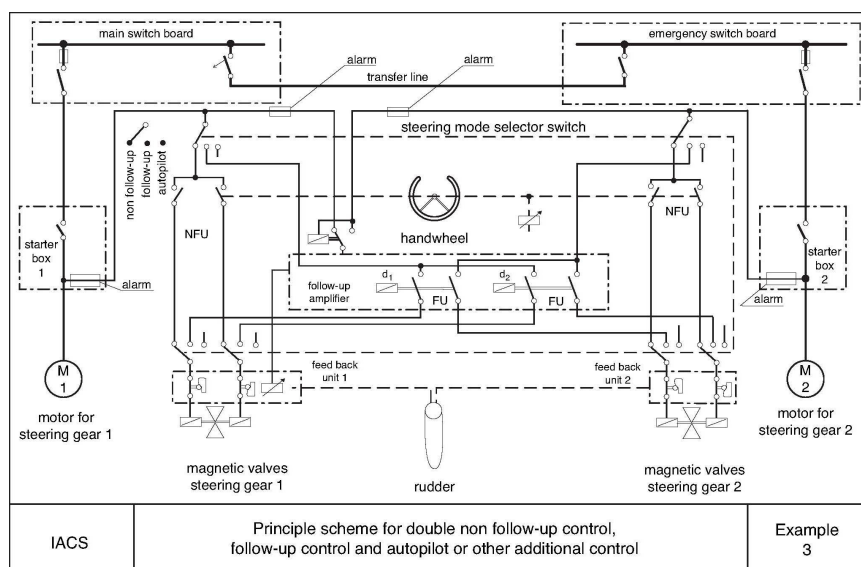
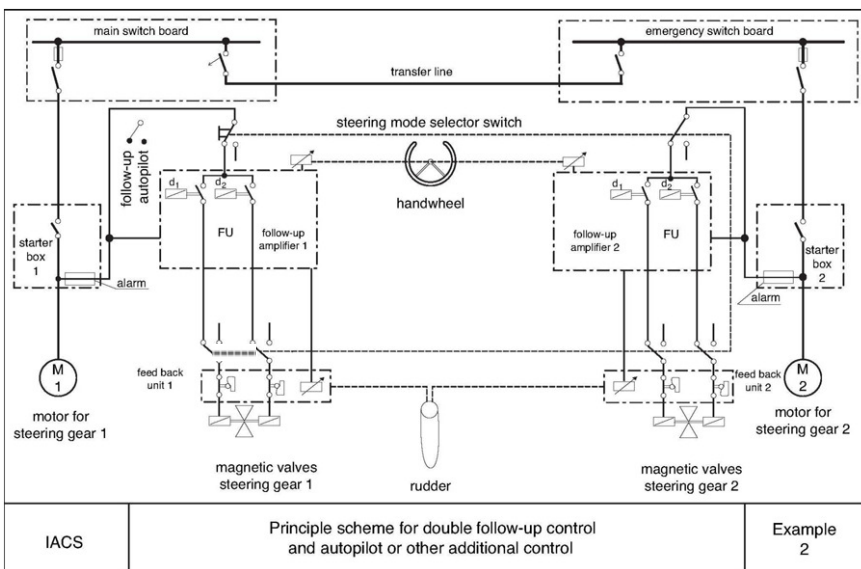
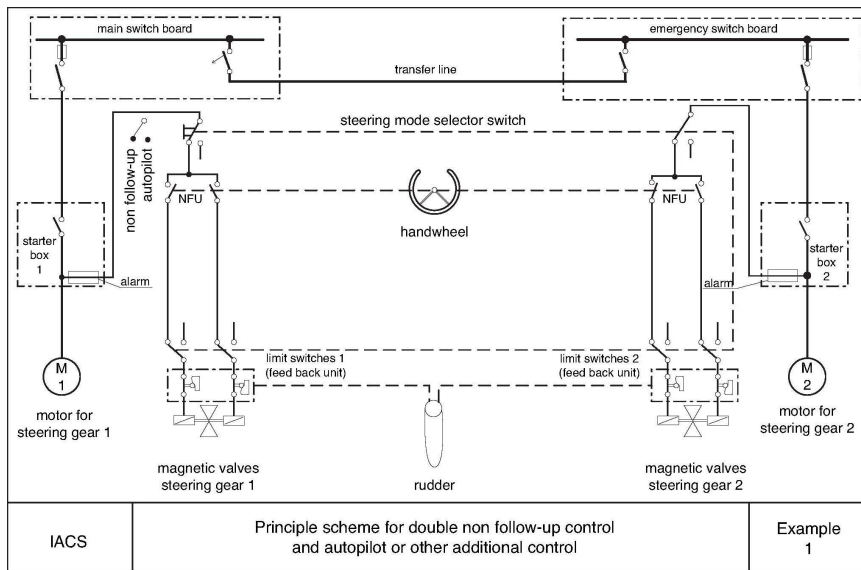

5.6 ELECTRICAL DRIVES FOR ANCHOR AND MOORING MACHINERY

5.6.1 In addition to the requirements referred to in the present Part of the Rules, the electrical drives of windlasses, anchor and mooring capstans and mooring winches shall comply with the *Rules for the classification of ships, Part 9. - Machines*, 6.3 and 6.4.

5.6.2 When alternating current squirrel - cage electrical motors are used, the electrical drives of the anchor and mooring machinery shall ensure, after 30 min operation at the rated load, activating directly stalling of the electrical motor in "on" position for at least 30 sec. for the anchor machinery and 15 sec. for the mooring machinery. For reconnecting stator winding motors, these requirements are applicable to operation of the motor with the winding producing maximum starting torque.

The direct-current electrical motors and alternating current wound-rotor motors shall withstand the above stated stalling conditions but at the torque twice that of the rated value; in this case, the voltage may be below the rated value.

After stalling condition the temperature rise shall not exceed 130 per cent of the permissible value.

5.6.3 In anchor and mooring capstans as well as in mooring winches, all speed steps intended only for mooring operations shall be included into the over-load protection of the electrical motor.

5.6.4 Anchor capstan power supply shall be in compliance with the requirements in 4.3.1 and 4.3.4.

5.7 ELECTRICAL DRIVES FOR PUMPS

5.7.1 The electrical motors of fuel and oil transfer pumps and separators shall be provided with the devices for remote switching off, located outside the space where these pumps are placed and outside the machinery casings but in close vicinity of the exits from these spaces.

5.7.2 The electrical motors of the pumps discharging the liquids overboard through the drains above the lightest waterline where lifeboats and liferafts are lowered, shall be provided with tripping devices located near the control stations of the driving machinery for lowering the relevant boats or rafts.

5.7.3 The electrical motors of the submersible bilge pumps and emergency fire pumps shall be provided with remote starting devices located above the bulkhead deck. These devices shall be provided with light signal indicating the engagement of the electrical drive (see the *Rules for the classification of ships, Part 17 – Fire protection*, 3.3.2).

5.7.4 The devices for switching off the electrical drives referred to in 5.7.1 and 5.7.2 shall be fitted in the enclosed boxes with glass covers, located in conspicuous positions with explanatory inscriptions.

5.7.5 Local starting of fire and bilge pumps by starting devices located adjacent to them shall be possible even in case of failure in their remote control circuits.

5.8 ELECTRICAL DRIVES OF FANS

5.8.1 The electrical motors for ventilation fans in machinery spaces shall be provided with at least two disconnecting switches. One of these switches shall be located outside these machinery spaces and their casings, but in close vicinity of the exits from those spaces. These disconnecting switches are recommended to be positioned together with similar switches referred to in 5.7.1.

5.8.2 The electrical motors for ventilation fans of cargo holds and galley fans shall be provided with disconnecting switches at locations readily accessible from the main deck, but outside the machinery casings. Electrical motors of forced exhaust ventilation from galley ranges shall be additionally provided with a disconnecting switch located inside the galley, regardless of the number of disconnecting switches.

5.8.3 The electrical motors for general shipboard ventilation shall be provided with at least two disconnecting switches, one of these shall be located in the bridge and the other accessible from the open deck.

For ships with the low power electrical installation (other than passenger ships), it is permitted to use one disconnecting switch located in the bridge or in a position readily accessible from the main deck.

5.8.4 The electrical motors of fans in the spaces protected by a smothering fire extinguishing system, shall be provided with a disconnecting switch operating automatically when fire extinguishing medium is discharged into the space.

5.8.5 The disconnecting switches of the electrical motors for fans referred to in 5.8.1; 5.8.2 and 5.8.3 shall be so grouped on board ship, that all these electrical motors could be stopped from not more than three positions.

5.9 ELECTRICAL DRIVES FOR LIFE BOAT WINCHES

5.9.1 The electrical drives for life boat winches shall comply with the requirements of the LSA CODE (RES MSC.48(66)).

5.9.2 The winch electrical drive controls shall be provided with self-return to the "stop" position.

5.9.3 A switch in the power circuit of the electrical motor shall be installed at the boat winch control station.

5.10 ELECTRICAL DRIVES OF WATERTIGHT AND FIRE DOORS

5.10.1 The electrical drives of watertight doors shall meet the requirements of the *Rules for the classification of ships, Part 3. - Hull Equipment*, 7.12.5.

5.10.2 Electrical drives for closing and position indicators of the watertight doors shall be supplied from the main, emergency and transitional sources in accordance with 4.3.1; 19.1.2.3 and 19.1.2.7.

5.10.3 Electrical drives for holding the fire doors in the open position (see the *Rules for the classification of ships, Part 17 - Fire protection, 2.1.4*), shall:

- .1 be supplied from the main and emergency source of electrical power;
- .2 be remotely controlled from the bridge for closing the doors individually, in groups or all doors simultaneously;
- .3 automatically close all the doors simultaneously in case of the supply voltage loss;
- .4 be so designed that any damage in the mechanism of closing any door could not render inoperative the systems of supply and operation of other doors.

5.11 ELECTRICAL DRIVES OF ACTIVE MEANS OF SHIP STEERING

5.11.1 The active means of the ship's steering include:

- .1 bow thrust's,
- .2 devices for active steering

5.11.2 Electrical drives of active means of the ship's steering shall be designed for the following modes of operation:

- 5.11.1.1 S2 - 30 min
- 5.11.1.2 S1

5.11.3 Switching devices of electrical drives for the active means of the ship's steering, shall be installed on the bridge. In case the ship is provided with the bow thrusts, an additional switching device shall be available at the local control station.

5.11.4 Electrical drive of the controllable pitch propeller shall be capable of being activated only, when the propeller blades are in neutral position.

5.11.5 The change of pitch of the controllable pitch bow thrusts, when electrical drive is on, shall be effected only from the bridge.

5.11.6 Electrical drives of the active means for the ship's steering, shall be protected against short circuit and overload. Light and sound signals may be fitted in the bridge instead of the overload protection.

5.11.7 The loss of supply of the electrical drive for active means of the ship's steering, shall activate light and sound signals on the bridge.

5.11.8 Restoring of the supply voltage shall not cause automatic starting of electrical motor for the drive of active means of the ship's steering.

5.11.9 Measuring instruments in accordance with 4.6.4.5 shall be fitted in the circuits of electrical drive for active means of the ship's steering.

5.12 INSTALLATION OF ELECTRICAL AND ELECTRONIC EQUIPMENT IN ENGINE ROOMS PROTECTED BY FIXED WATER-BASED LOCAL APPLICATION FIRE-FIGHTING SYSTEMS(FWBLAFFS)

5.12.1 The electrical drives of the fixed water-based local application fire-fighting systems shall meet the requirements of the *Rules for the classification of ships, Part 17 - Fire protection* item 3.12.

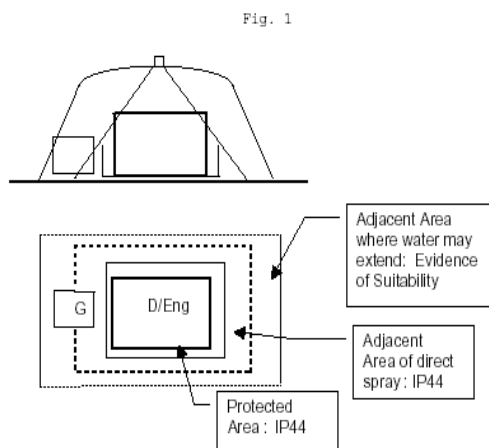

Fig. 5.12.1

5.12.2 Definitions

Protected space:

- Is a machinery space where a FWBLAFFS is installed.

Protected areas:

- Areas within a protected space which is required to be protected by FWBLAFFS.

Adjacent areas:

- Areas, other than protected areas, exposed to direct spray.
- Areas, other than those defined above, where water may extend.

5.12.3 Electrical and electronic equipment enclosures located within areas protected by FWBLAFFS and those within adjacent areas exposed to direct spray are to have a degree of protection not less than IP44, except where evidence of suitability is submitted to and approved by the *Register*.

5.12.4 The electrical and electronic equipment within adjacent areas not exposed to direct spray may have a lower degree of protection provided evidence of suitability for use in these areas is submitted taking into account the design and equipment layout, e.g. position of inlet ventilation openings, cooling airflow for the equipment is to be assured.

5.13 REQUIREMENTS FOR UNINTERRUPTIBLE POWER SYSTEM (UPS) UNITS AS ALTERNATIVE AND/OR TRANSITIONAL POWER

5.13.1 Scope:

These requirements to UPS units, as defined in IEC 62040-3:2011, apply when providing an alternative power supply or transitional power supply to services as defined in section 9. and 19. these Rules.

A UPS unit complying with these requirements may provide an alternative power supply as an accumulator battery in terms of being an independent power supply for services defined in items 9.3.1.3 – 9.3.1.6 and 19.1.2.1.4 – 19.1.2.1.6 these Rules.

5.13.2 Definitions:

5.13.2.1 Un-interruptible Power System (UPS) - combination of converters, switches and energy storage means, for example batteries, constituting a power system for maintaining continuity of load power in case of input power failure (IEC 62040-3:2011).

5.13.2.2 Off-line UPS unit - a UPS unit where under normal operation the output load is powered from the bypass line (raw mains) and only transferred to the inverter if the bypass supply fails or goes outside preset limits. This transition will invariably result in a brief (typically 2 to 10 ms) break in the load supply.

5.13.2.3 Line interactive UPS unit - an off-line UPS unit where the bypass line switch to stored energy power when the input power goes outside the preset voltage and frequency limits.

5.13.2.4 On-line UPS unit - a UPS unit where under normal operation the output load is powered from the inverter, and will therefore continue to operate without break in the event of the supply input failing or going outside preset limits.

5.13.3 Design and construction

5.13.3.1 UPS units are to be constructed in accordance with IEC 62040-1:2017, IEC 62040-2:2016, IEC 62040-3:2011, IEC 62040-4:2013 and/or IEC-62040-5-3:2016, as applicable, or an acceptable and relevant national or international standard.

5.13.3.2 The operation of the UPS is not to depend upon external services.

5.13.3.3 The type of UPS unit employed, whether off-line, line interactive or on-line, is to be appropriate to the power supply requirements of the connected load equipment.

5.13.3.4 An external bypass is to be provided.

5.13.3.5 The UPS unit is to be monitored and audible and visual alarm is to be given in a normally attended location for:

- power supply failure (voltage and frequency) to the connected load,
- earth fault,

- operation of battery protective device,
- when the battery is being discharged, and
- when the bypass is in operation for on-line UPS units.

5.13.4 Location

5.13.4.1 The UPS unit is to be suitably located for use in an emergency.

5.13.4.2 UPS units utilising valve regulated sealed batteries may be located in compartments with normal electrical equipment, provided the ventilation arrangements are in accordance with the requirements of IEC 62040-1:2017, IEC 62040-2:2016, IEC 62040-3:2011, IEC 62040-4:2013 and/or IEC-62040-5-3:2016, as applicable, or an acceptable and relevant national or international standard.

5.13.5 Performance

5.13.5.1 The output power is to be maintained for the duration required for the connected equipment as stated in Section 9 and Section 19 of this Rules.

5.13.5.2 No additional circuits are to be connected to the UPS unit without verification that the UPS unit has adequate capacity. The UPS battery capacity is, at all times, to be capable of supplying the designated loads for the time specified in the regulations.

5.13.5.3 On restoration of the input power, the rating of the charge unit shall be sufficient to recharge the batteries while maintaining the output supply to the load equipment.

5.13.6 Testing and survey

5.13.6.1 UPS units of 50 kVA and over are to be surveyed by the *Register* during manufacturing and testing.

5.13.6.2 Appropriate testing is to be carried out to demonstrate that the UPS unit is suitable for its intended environment. This is expected to include as a minimum the following tests:

- Functionality, including operation of alarms;
- Temperature rise;
- Ventilation rate;
- Battery capacity.

5.13.6.3 Where the supply is to be maintained without a break following a power input failure, this is to be verified after installation by practical test.

6 LIGHTING

6.1 GENERAL REQUIREMENTS

6.1.1 In all ship's rooms, spaces and locations where the illumination is essential for safety of navigation, control of machinery and gear devices as well as residence and evacuation of passengers and crew, stationary main lighting fixtures shall be provided, which shall be supplied from the main source of electrical power.

The list of rooms, spaces and locations where the emergency lighting fixtures shall be installed in addition to main lighting, is referred to in 9.3.1.1 and 19.1.2.1.1.

6.1.2 Lighting fixtures fitted in spaces where they are exposed to possible mechanical damages, shall be provided with protection gratings.

6.1.3 Lighting fixtures shall be so arranged as to prevent heating of cables and adjacent material exceeding the permissible temperature.

6.1.4 In rooms, spaces and locations with luminescent lamps where, machines and devices with visible rotating parts are located, provisions shall be made to prevent stroboscopic effect.

6.1.5 External-illumination lighting fixtures shall be so installed, that no light obstruction of the ship's navigation could occur.

6.1.6 In rooms and spaces illuminated with the discharge lamps which do not ensure continuity of light at voltage variations according to 2.1.3, provision shall also be made for lighting fixtures with incandescent lamps.

6.1.7 Battery rooms and other spaces classified as hazardous, shall be illuminated with lighting fixtures located in adjacent safe spaces through gastight windows or with the explosion-proof lighting fixtures located in these spaces. (see 2.9).

6.2 POWER SUPPLY OF MAIN LIGHTING CIRCUITS

6.2.1 The distribution boards of the main lighting shall be supplied by separate feeders from the main switchboard. The main lighting distribution board may supply the electrical drives of non-essential consumers rated up to 0,25 kW as well as individual cabin heaters rated up to 10 A.

6.2.2 The protective devices of lighting end circuits shall be designed for a current rating not in excess of 16A, the total load current of all the consumers connected, exceeding not 80 per cent of the rated current of the protective device.

The number of lighting fixtures supplied by end lighting circuits shall not exceed that referred to in the Table 6.2.2.

Table 6.2.2

No.	Voltage	Maximum number of lighting fixtures
1	up to 50 V	10
2	51 V to 120 V	14
3	121 V to 250 V	24

Cabin fans and other minor appliances may be supplied by end lighting circuits.

6.2.3 Lighting of corridors, machinery spaces, propeller shaft tunnels, cargo pump stations and boiler water level indicators, shall be supplied by at least two independent feeders, with the lighting fixtures arranged so, that even in case of failure of either feeder, the uniform lighting is ensured. These feeders shall be supplied from different distribution boards, supplied from different busbar sections in case the main board is effected with such busbars.

For cargo ships with the low power electrical installation it is allowed that lighting of the above spaces, except for machinery spaces, be supplied by one feeder from the common distribution board or from the main switchboard directly.

6.2.4 Lighting fixtures and socket outlets in accommodation spaces, shall be supplied from the lighting distribution board by separate feeders other than that intended for supplying the common lighting fixtures.

6.2.5 If the ship is divided into main fire zones, the lighting of each fire zone shall be supplied by two feeders completely independent from the feeders of the lighting fixtures in other fire zones.

The lighting feeders shall be so installed that the fire in one zone cannot damage the feeders supplying the lighting circuits in other zones.

When the busbars of the main switchboard are subdivided into sections, the feeders of lighting fixtures in fire zones shall be supplied from different busbar sections.

6.2.6 Permanently installed lighting fixtures in cargo spaces shall be supplied from a special board which is provided, in addition to switchgear and protective devices, with signal lamps to monitor each individual lighting circuit. For ships with the low power electrical installation, the lighting fixture may be supplied from the general purpose distribution board located in the wheelhouse and in this case, signals lamps are required to indicate the presence of voltage in the supply circuits of lighting fixtures.

6.3 EMERGENCY LIGHTING

6.3.1 The illumination intensity obtained from the emergency lighting fixtures in rooms, spaces and locations referred to in 9.3.1.1 and 19.1.2.1.1 shall be at least equal to 10 per cent of the illumination intensity of the main lighting fixtures (see 6.7). In the machinery space the illumination from the emergency lighting fixtures shall be equal to 5 per cent of the main illumination if the socket outlets fed from the emergency lighting circuit are provided. The illumination intensity of the evacuation paths to the deck shall be at least 5 Lx.

6.3.2 To obtain the illumination required in 6.3.1, the lighting fixtures with incandescent lamps may be combined with luminescent lamps.

6.3.3 The main lighting fixtures may be used as emergency lighting fixtures if they are fed from the emergency switchboard.

6.3.4 The emergency lighting shall be so designed that the of fire or other casualty in the space containing the main source of electrical power or lighting transformers if fitted, does not affect it.

6.3.5 Stationary lighting fixtures with built-in accumulators, automatically recharging from the main lighting circuit and acting upon the failure in main lighting system, may be used for emergency lighting.

6.3.6 Emergency lighting fixtures and lamps in accordance with 6.3.3 shall be marked in red.

6.4 SWITCHES IN LIGHTING CIRCUITS

6.4.1 Two-pole switches shall be used in all lighting circuits.

In dry accommodations and service spaces it is allowed to use single-pole switches in circuits disconnecting individual lighting fixtures or groups of lighting fixtures rated at not more than 6A and also in lighting fixture circuits operating with safety voltage.

6.4.2 Provision shall be made for switching off all the permanently installed external lighting fixtures from the bridge or from any other permanently watched location on the upper deck.

6.4.3 The switches of lighting circuits of the fire extinguishing stations, shall be located outside these spaces.

6.4.4 The lighting switches for illumination of spaces behind free - standing switchboards, shall be installed near each access's door behind such switchboards.

6.4.5 In emergency lighting circuits local switches shall not be used for individual lighting fixtures, except in case they serve also as the main lighting fixtures in accordance with 6.3.3.

Exceptionally, a switch shall be provided for switching off emergency lighting in the bridge.

6.5 GAS DISCHARGE LIGHTING FIXTURES

6.5.1 Suppressers, condensers and other outfitting of gas discharge lighting fixtures shall be protected by securely earthed metal enclosures.

6.5.2 Condensers of 0,5 and more μF , shall be fitted with discharging devices, which shall ensure that the voltage

of the condenser 1 minute after disconnection from supply does not exceed 50 V.

6.5.3 Suppressers and transformers having a higher inductively shall be installed as close as possible to the lighting fixture they serve.

6.5.4 Gas discharge lamp installations supplied at over 250 V shall be provided with warning notices giving the voltage rating. All live parts of such installations shall be suitably protected.

6.6 SOCKETS AND PLUGS

6.6.1 Sockets for portable lighting fixtures shall be installed at least:

- .1 on deck near the windlass;
- .2 in the gyrocompass room;
- .3 in the radio equipment converter room;
- .4 in the steering gear compartment;
- .5 in the emergency power source compartment;
- .6 in the machinery space;
- .7 behind the main switchboard;
- .8 in special electrical spaces;
- .9 in the propeller shaft tunnel;
- .10 in the navigating bridge;
- .11 in the radio room;
- .12 in the vicinity of winches;
- .13 in the vicinity of the log and echosounder wells;
- .14 in the spaces of central ventilation and air-conditioning installations;

6.6.2 Sockets with different voltages shall be so designed as to prevent insertion of a plug indented for lower voltage in the socket intended for higher voltage.

6.6.3 Sockets for portable lighting and other consumers installed on the open decks, shall be mounted so that the plug will be inserted from down upwards.

6.6.4 Sockets shall not be fitted in machinery spaces below the plating, in the enclosed fuel and oil separator rooms or where approved safe-type equipment is required.

6.7 ILLUMINATION

6.7.1 The illumination of particular spaces shall not be below the values referred to in the Table 6.7.

The main lighting standards stated in this Table refer to a level of 850 mm above the flooring, while the standards for main plus working place lighting, to the level of working surfaces.

6.7.2 On Ships provided with lighting circuits supplied a voltage below 30V the illumination of particular spaces, is subject to special consideration by the *Register* in each particular case.

Table 6.7

No.	Spaces		Illumination, lux			
			Luminescent lighting		Incandescent lighting	
			General + local	General	General + local	General
1	2		3	4	5	6
1	Radio room	General lighting	–	–	–	100
		Working table	–	–	200	–
2	Chartroom	General lighting	–	100	–	50
		Chart table	150	–	150	–
3	Navigating bridge	General lighting	–	75	–	50
4	Engine room, spaces for switchboards, manoeuvring and control stations and panels, spaces for automation facilities and gyrocompass	General lighting	–	75	–	75
		Surfaces of switch gears and control desks	200	200	150	75
		Main engine control station	150	100	150	75
		Passageways between boilers, machinery, stairways, platforms etc.	–	75	–	30
		Font side of boilers	100	75	–	30
5	Battery compartment	Space	–	75	–	50
6	Propeller shaft tunnels, log echo-sounder well chain lockers	General lighting	–	50	–	20
		Surfaces of shaft bearings and connection flanges, etc.	75	–	50	–
7	Passageways on decks, gangways and lifeboat positions	General lighting	–	50	–	20
8	Overside spaces in way of lifeboat lowering	Near the loadline	–	–	–	5

6.8 SIGNAL AND NAVIGATIONAL LIGHTS

6.8.1 The navigational lights distribution board shall supply, by separate feeders, the masthead lights, sidelights and sternlights and on tugs, pusher boats, fishing, pilot, air-cushion vessels and vessels with restricted ability of manoeuvring also permanently installed lights referred to in COLREG 1972., Table 2.4.1.4.

6.8.2 The signal and navigational lights distribution board shall be supplied by two feeders intended for this purpose only:

- .1 one feeder from the main switchboard through the emergency switchboard;
- .2 the other feeder from the nearest distribution board, which is not supplied from the emergency switchboard.

It is permitted to install the navigational lights control device into the bridge control desk being supplied in accordance with 4.5.2.

In ships where the main source of power is an accumulator battery and the main switchboard is installed in the wheelhouse the signal and navigational lights may be supplied and controlled directly from the main switchboard.

6.8.3 Signal and navigational lights shall be connected to the supply circuit through a flexible cable with a plug connector.

6.8.4 The supply circuits of navigational lights shall be two-wire system with a double-pole switch for each circuit installed in the navigation lights distribution board.

6.8.5 Each navigational light supply circuit, shall be provided with two-pole protection and a visual indicator to show proper functioning of the lights in accordance with the COLREG 1972. The visual indicator shall be such, that its failure does not affect the proper function of the navigational lights. The voltage drop at the distribution board supplying these lights including the system of indicating their operation, shall not exceed 5 per cent at rated voltage up to 30 V and 3 per cent at rated voltage above 30 V.

6.8.6 Irrespective of the signalling required in 6.8.5, the provision shall be made for audible signalling functioning automatically in case of failure of any navigational light in switched-on position.

The audible signalling shall be supplied from sources or feeders other than those by which the navigational lights are fed, or from an accumulator battery.

6.8.7 Lamp holders and lamps used for signal and navigational lights, shall comply with the requirements of the COLREG 1972.

7 INTERNAL COMMUNICATION, ALARMS AND SIGNALLING

7.1 GENERALLY

Alarms and signalling have to be accordance to IMO Resolution A.830(19) – Code of Alarms and Indicators, 1995.

7.2 ELECTRICAL ENGINE ROOM TELEGRAPH

7.2.1 In addition to the requirements of the present Section, the engine room telegraphs shall meet the requirements of the *Rules for the classification of ships, Part 7 - Machinery Installations*, 1.9.

7.2.2 Engine room telegraphs shall be provided with visual indication of the presence of voltage in the power circuit, as well as audible warning of voltage loss.

7.2.3 Engine room telegraphs installed in the navigating bridge shall be provided with illuminated dials and possibility for adjusting the illumination intensity.

7.2.4 Engine room telegraphs shall be fed from the main switchboard or from the navigational aids distribution board.

If the ship is provided with the main bridge control console the engine room telegraph may be fed from this control console.

7.2.5 The engine room telegraph transmitter shall be so installed in the navigating bridge, that the telegraph operating handle is shifted when orders are given in the same direction with the required ship direction. Vertical position of the handle shall correspond to the "stop" order.

7.2.6 Where engine room telegraphs and devices for remote control of the main engines and the controllable pitch propellers are installed on sloping desks of control panels, the handle at the "stop" position shall be perpendicular to the panel surface and precisely fitted in that position.

7.2.7 Where two and more engine room telegraphs are located closely to one another on one deck, they shall ensure the transmission and the reception of orders by all of them without additional changing-over.

Change-over to telegraphs located on another deck or in another part of the ship shall be effected by means of change-over switch fitted on the navigating bridge.

7.2.8 Each engine room telegraph shall be provided with an audible signal device ensuring the activation of an audible signal on the bridge and the engine room when transmitting the order. The signal will automatically cancel upon acknowledgement of order. In case of wrong reply, the audible signal shall not stop. (see the *Rules for the classification of ships, Part 7 - Machinery Installation* 1.9)

7.2.9 For ships less than 30 m in navigation areas 5, 6, 7, 8 is recommended engine room telegraph.

7.3 INTERNAL SERVICE COMMUNICATION

7.3.1 In case there are no other types of independent two-way voice communication facilities, provision shall be made for independent two-way telephone communication between the navigating bridge and the radio room as well as between navigating bridge and the machinery control stations. In case of an enclosed or non-enclosed main control station, an independent, two-way voice communication shall be provided between that station and the navigating bridge and between the bridge and local control stations of propulsion machinery and starting devices.

If there are no other types of independent, two-way voice communication facilities for this purpose, provision shall be made for independent, two-way telephone communication or the existing independent, two-way telephone communication between the navigating bridge and the main control station with telephones connected in parallel and installed in the local control stations.

7.3.2 In addition to the communication facilities specified in 7.2.1, provision shall be made for separate system of telephone communication between the navigating bridge and forecabin, poop deck, lookout on the mast, steering gear compartment, emergency switchboard compartment, gyrocompass room, fire smothering station, spaces containing electric propulsion motors, local control desks, bow thrusters propellers, crane operating cabin in floating cranes, engineers accommodation and other spaces with equipment ensuring safety of the ship's navigation. The ship's address system, two-way loud speaker, may be used instead of a telephone set. No additional communication facilities are required besides those referred to in this item.

When portable radiotelephones are used as an addition to the required means of communication, they shall comply with the requirements of the SOLAS 74 Ch. IV.

7.3.3 The system of the internal service communication shall ensure clear communication from any individual telephone set under specific noise conditions in place where such communication facilities are installed.

In the high noise intensity spaces, measures shall be taken for noise absorption or additional earphones shall be provided.

7.3.4 For communication facilities referred to in 7.3.1 and 7.3.2 the sources of power supply shall be provided to ensure their operation in case of voltage loss on the main switchboard (Section 9 or 19 of this Part).

7.3.5 A damage or disconnection of one telephone set shall not affect the proper function of remaining sets.

7.3.6 The telephone sets specified in 7.3.1 for independent, two-way voice communication between the navigating bridge and main control station or the navigating bridge and local control stations of the propulsion machinery and starting devices, shall be provided with the visual and audible signals to indicate the call, both in the main control station and in machinery space.

7.3.7 The two-way loudspeaker device may be independent or connected to the command broadcast apparatus specified in the Section 9 or 19 of this Part.

7.3.8 For ships less than 30 m in navigation areas 5.6,7,8 it is not possible direct voice communication bridge-engine room shall be provided communication by telephone.

7.4 GENERAL ALARM SYSTEM

7.4.1 Ships in which a general alarm given by a voice or by any other means cannot be heard simultaneously in all locations where people may be, shall be provided with electrical general alarm system that will ensure audibility of signals in all such places.

7.4.2 Sound devices shall be installed in:

- .1 machinery spaces;
- .2 public spaces with floor area exceeding 150 m²;
- .3 corridors of accommodations, service and other public spaces;
- .4 open decks;
- .5 working spaces.

7.4.3 General alarm system shall be supplied from the main switchboard and from the emergency switchboard in accordance with 9.3.1.3 and 19.1.2.1.4 and from the transition source of electrical power in accordance with 9.3.7.3 and 19.1.2.7.3.

General alarm system may be supplied from the main switchboard and from an independent accumulator battery if provision is made for an automatic change-over of general alarm circuits to the battery in case of voltage loss on the ship's mains. In this case, no supply either from the emergency source or from a transition source of electrical power is necessary.

7.4.4 The general alarm system shall be supplied continuously, irrespective of whether the accumulator battery is set for charging or discharging.

7.4.5 In case a separate accumulator battery is installed to supply the general alarm system, it may also supply other internal communication facilities if the battery capacity is sufficient for simultaneous supply of all consumers for at least 3 hours and also if the facilities are so designed, that a failure in one circuit will not interfere with the operation of other circuits, provided no longer supply time is foreseen for these facilities.

7.4.6 In the supply circuits of the general alarm system only the short circuit protection shall be provided. Protective devices shall be fitted in both conductors of the feeder and also in circuits of each sound device.

Protection of several sound devices by one common protective device is permitted, if in space where they are installed, good audibility of other sound devices provided with independent protection is ensured.

7.4.7 General alarm sound devices shall be so located that a signal is clearly heard against the noise in the relevant space. Sound devices installed in spaces with high intensity of noise, shall be fitted additionally with luminous indicators.

The sound of general alarm devices shall differ in tone from the sounds of all other kinds of signalling.

7.4.8 The general alarm system shall be actuated by means of a double-pole self-return switch from the navigating bridge and, except for the ship's whistle also from the space

intended for the watch-keeping when in port, if such a space is provided. The general alarm shall continue to function after it has been triggered until is manually turned off or is temporarily interrupted by a message on the public address system.

If the general alarm signal is not audible from the navigating bridge or from the station where it has been given, a pilot lamp shall be fitted behind the switch to indicate that the general alarm system is activated.

The switches shall be provided with the inscriptions indicating their purpose.

7.4.9 No switching device shall be incorporated into the circuits of the general alarm system other than the switch referred to in 7.3.8. When a circuit breaker is installed in the distribution board of the general alarm system, it shall be interlocked in the "on" position or otherwise protected from access thereto by unauthorised persons.

Intermediate contractors activated by the switch may be installed, but not more than one contractor in each circuit.

7.4.10 Sound devices, switching gears and devices of the general alarm system shall be provided with readily visible distinctive symbols.

7.4.11 It is necessary that the supply circuit of general alarm sound devices shall consist of two separate sections controlled by one switch. In spaces of larger area (machinery spaces, boiler rooms, fish processing shops and other special spaces), sound devices shall be so arranged that they are connected to different sections.

7.5 FIRE DETECTION AND ALARM SYSTEMS

7.5.1 Besides the requirements of the present part of the Rules, these systems shall comply with the *Rules for the classification of ships, Part 17 - Fire Protection*, Section 4.

7.5.2 Application of fire detectors located in spaces where explosive vapours may accumulate or in a flow of air sucked out of these spaces is regulated in 2.9 and 19.2.

7.5.3 Fire detection systems shall be fed from two independent sources of electrical power solely for that purpose by separated feeders reserved. When the main source of power is the main switchboard, as reserve source of power shall serve emergency source of power or a special accumulator battery whose capacity and arrangement shall be in compliance with the requirements of 9.3 and 9.1.2.

Provision shall be made for an automatic change-over of supply to the reserve source of supply if necessary with the corresponding audible alarm.

7.5.4 The fire detection system operating on the principle of smoke detection by analysis of the air coming from the protected spaces into the indicating unit together with the belonging fans, shall be fed with separate feeders from the main switchboard and from the emergency switchboard, if the emergency source of power is a generator.

7.5.5 Indicating units of the fire detection system, other than the smoke detection system shall meet the following requirements:

- .1 any signal or failure in a circuit shall not affect normal operation of other circuits;
- .2 a fire-detection signal shall prevail over other signals led to the indicator and shall enable to determine the location of the space wherefrom this fire-detection signal has arrived;
- .3 contact-type fire detectors are equipped with normally closed contacts. Detectors with normally open contacts may be used if the contacts are hermetically sealed and if the proper function of their circuits is permanently controlled.
- .4 provision shall be made for monitoring their proper operation

7.5.6 Indicating units of the fire detection system shall produce information in compliance with the Table 7.5.6.

A visual signal of fire detection system shall consist of two indicators (two lamps or a double filament) or one indicator capable of continuous correctness checking of the lamp.

The colour of a light signal shall comply with the requirements of 4.6.5.

Visual signals shall differ for each kind of information. Signals intended to determine the location of the space wherefrom a signal has arrived may be common with the signal of fire detection or failure detection.

Visual signals shall function from the moment a signal is received, till the moment the cause of their activation is removed; the signal specified under No 1 of the Table 7.5.6 shall function continuously irrespective of other signals.

7.5.7 Fire detectors in the cargo space shall be connected at least to two separate circuits.

7.5.8 If the receipt of fire detection alarm is not confirmed within 2 min., automatic fire alarms shall operate in the machinery, accommodation and other spaces where members of the crew may be present, warning that there is a fire on ship.

Table 7.5.6

No.	Signal	Signal activated by temperature fire detection system	Signal activated by the air analysis from protected spaces
1	2	3	4
1	Operation of device	visual	visual
2	Supply from emergency source of power	visual	visual
3	Fire detection and location of spaces where fire is detected	audible visual	audible visual
4	No draught in detection chamber		audible visual
5	No draught in pipe line		visual audible (recommended)
6	Failure in detector circuits	visual audible	
7	Failure spots of detector circuits	visual audible	
8	Open position of detector circuit (recommended)	visual audible	
9	Voltage loss	visual audible	visual audible

7.6 WARNING ALARM OF FIRE SMOTHERING SYSTEM RELEASE

7.6.1 The warning alarm system shall comply with the requirements of the *Rules for the classification of ships, Part 17 - Fire Protection*, 4.3.

7.6.2 The alarm system shall be fed from the main switchboard and an accumulator battery having a capacity sufficient for feeding the system during 30 min.

Provision shall be made for an automatic change-over of power supply to the accumulator battery in case of voltage loss in the main switchboard busbars.

7.7 INDICATION OF CLOSURE OF WATERTIGHT AND FIRE DOORS

7.7.1 Indication of closure of watertight doors shall comply with the requirements of the *Rules for the classification of ships, Part 3 - Hull Equipment*, 7.4.1.6.4 to 7.4.1.6.9; 17.12.2.8 respectively and indication of fire doors position, with the requirements of the *Rules for the classification of ships, Part 17 - Fire Protection*, 2.2.7.3 respectively.

7.7.2 On passenger ships degree of mechanical protection of electrical components for watertight door necessarily situated below the bulkhead deck shall provide suitable protection against the ingress of water:

- .1 electrical motors, associated circuits and control components; protected to IP67 standard;
- .2 door position indicators and associated circuit components; protected to IP68 standard; and
- .3 door movement warning signals; protected to IP66 standard.

7.8 SIGNALS IN ENGINEERS' ACCOMMODATION SPACES

7.8.1 In the engineers' accommodation spaces the sound signalling system shall be provided for the emergency call which is activated manually from the propulsion machinery control station in the engine room or from the central control station, if any.

8 PROTECTION

8.1 GENERAL REQUIREMENTS

8.1.1 Each outgoing circuit of distribution board shall be protected against short circuit and overload by the protective devices installed at the inception of each circuit. No overload protection is required for the distribution board supply circuit if its outgoing circuits are provided with individual protective devices and if the supply cable is selected on the basis of maximum service current.

8.1.2 Protective devices shall be selected in accordance with the characteristics of the equipment under protection in order to make them activate under inadmissible overloads.

8.1.3 The protection system shall be selective with regard to overload and short - circuit currents. Such protection system shall be so designed that failure of non-essential consumers and their circuits could not adversely affect efficient operation of ship's generating plant and supply of essential consumers.

Short - circuit and overload protective devices shall not activate at starting currents of the electrical equipment being under protection.

8.1.4 Overload protection in different distribution systems (see 4.1) shall be provided in:

- .1 not less than two phases
 - in insulated three-wire, three-phase system;
- .2 all phases
 - in a three - phase, three - wire system with earthed neutral;
 - in a three - phase, four - wire system with earthed neutral;
- .3 plus - pole, or one conductor
 - in insulated two-wire system,
 - in insulated one-phase, two-wire system,
- .4 non-earthed conductor
 - in one phase, two-wire system with one wire earthed,
- .5 plus-pole
 - single-wire system using hull as return wire.

Other power distribution systems which are not in compliance with 4.1 with regard to overload protection, shall be taken into consideration by the *Register* in each particular case.

8.1.5 Short-circuit protection shall be fitted in each insulated pole of a direct current distribution system or in each phase of an alternating current system.

Short-circuit protection shall be set to activate at not less than 200 per cent of the rated current. Activation may be instantaneous or time delayed to ensure selective protection.

The same protective device may be used for the short-circuit protection of the consumer and belonging supply cable.

8.1.6 Where cables of the reduced cross-sectional area are used in some parts of a ship's network, additional protection shall be provided for each of such cables if the basic protection is not capable to protect the cable with reduced cross-sectional area.

8.1.7 Protective devices excluding the possibility of immediate repeated switching on after the protection activation, shall not be used in supply circuits of the emergency switchboard as well as in those of emergency consumers.

8.1.8 Short-circuit protection of consumers located in the areas and spaces with the explosion risk shall activate immediately.

8.2 PROTECTION OF GENERATORS

8.2.1 Generators not intended for parallel operation shall be protected against short-circuit and overload. Melting fuses may be used as protective devices for generators rated under 50 kW (kVA).

8.2.2 Generators intended for parallel operation shall be provided with the protection:

- .1 against overload;
- .2 against short-circuit;
- .3 against reverse current or reverse power;
- .4 against undervoltage.

It is recommended that the device used for generator overload protection shall be provided with visual and audible alarms to operate with a time - delay of up to 15 min at the loads from 100 to 110 per cent of the rated current. The generator under overload protection at loads from 110 per cent to 150 per cent of the rated current, shall be switched off with a time-delay to suit generator thermal strength.

It is recommended that for setting of the protection device at 150 per cent of the rated generator current, the time delay shall not exceed 2 min for the alternating-current generator and 15 sec. for a direct-current generator. When loaded in excess of 150 per cent of the rated current, the generator shall be immediately switched off.

Overload protection and time delay settings shall be selected to suit the overload characteristics of the generator prime mover so that within the time-delay it is capable to develop the necessary output.

The protective devices used for generator overload protection shall not prevent the possibility of restarting the generator immediately.

8.2.3 Arrangements shall be provided to automatically and gradually disconnect the less essential consumers in the event of the generator overload. This load shedding may be carried out in one or several steps, depending on the complexity of ship's network and the generator ability to sustain the overload.

This requirement may be dispensed with in the case of low power electrical installations (up to 50 kVA) if approved by the *Register*.

8.2.4 Reverse-current or reverse-power protection of generators intended for parallel operation shall be selected to suit the prime mover characteristics.

The respective protection settings shall be in accordance with those referred to in Table 8.2.4.

Table 8.2.4

Kind of current	Ranges of reverse-current or reverse-power protection settings related to generator prime mover	
	Turbines	Internal combustion engines
1	2	3
Alternating current	2-6% of generator rated power (kW)	8-15% of generator, rated power (kW)
Direct current	2-15% of generator rated current (A)	8-15% of generator, rated current (A)

Reverse-current protection of direct-current generators shall be installed in the pole to which the equaliser lead is not connected. Reverse-current or reverse-power protection shall still be capable for operation even if the voltage is reduced to 60 per cent, irrespective that reverse current or reverse power may have altered values proportional to such voltage drop.

Reverse-current or reverse-power protection shall ensure transfer of power from the ship's network (for example from cargo winches).

8.2.5 Undervoltage protection shall ensure the possibility of a reliable switching-on of the generator to the busbars down to voltages till 85 per cent of its rated voltage and shall ensure switching off the generator at the voltage drop across the terminals within the range of 70 to 35 per cent of the rated value.

Undervoltage protection shall operate with a time-delay when switching off the generator and instantly at the repeated switching-on, if the minimum required voltage has not been reached.

8.2.6 Undervoltage protection shall function reliably even in case of frequency drop to 25 per cent of the generator rated frequency.

8.2.7 Protective devices shall be provided for generators with ratings of 1.000 kVA and over, against internal faults as well as for protection against damage of cable connections between the generators and associated circuit breakers.

8.2.8 If the direct current generator is driven with turbine and provided with parallel operation, shall be provided device for generator's circuit break switch off in case of release rpm protection device.

8.2.9 Protective devices with time delay for circuit breaker opening shall be selected in such a way that after the time delay the normal short-circuit current is higher than the minimum operation current of protective tripping device.

8.2.10 In generator excitation systems melting fuses may be used as protective devices for semi-conductor elements.

8.3 PROTECTION OF ELECTRICAL MOTORS

8.3.1 Outgoing feeders from switchboards and power distribution boards, supplying electrical motors rated at over 0,5 kW shall be provided with short-circuit and overload protection devices as well as with zero-voltage protection, if the motor need not be automatically restarted.

The overload and zero-voltage protective devices may be installed in the motor starter.

The overload and zero-voltage protective devices may be installed in the motor starter.

8.3.2 The overload protection for continuously loaded motors shall be so set as to disconnect the motors over a range of 105 to 125 per cent of the rated current. The overload protection may be replaced by visual and audible alarms in agreement with the *Register*.

8.3.3 The supply circuits of fire pump electrical drives shall not be provided with the protective devices operating on the principle of electrothermal relays.

The overload protective devices may be substituted by visual and audible alarms.

8.4 STEERING GEAR ELECTRICAL EQUIPMENT PROTECTION

8.4.1 For electrical or electrohydraulic driven steering gear, only short-circuit current protection shall be provided for electrical motors and control systems.

Visual and audible alarms shall be provided for the motor overload instead of the overload protection. Also, visual and audible alarms shall be provided in case of voltage loss in any phase (see 5.5.11).

8.4.2 Circuit breakers used to protect direct current motors from short-circuit currents shall be set for instantaneous release at currents within 300 and 400 per cent of the rated current of the motor under protection, while alternating-current motors shall be set for instantaneous release at currents exceeding 25 per cent of the peak starting current of the motor under protection.

In case the melting fuses are used as protection, the selected fuse rated current shall be one grade higher than required by the electrical motor starting current.

8.4.3 Electrical motors of the active ship's steering drive shall be provided with short-circuit and overload protective devices.

Overload protective device shall be fitted with visual and audible alarms and the electrical motor shall be disconnected over the range referred to in 8.3.2.

Short-circuit protection shall be in compliance with the requirements of 8.4.2.

8.5 PROTECTION OF TRANSFORMERS

8.5.1 Short-circuit and overload protective devices shall be installed in the transformer supply feeders.

Transformers rated up to 6,3 kVA may be protected by fuses only. The overload protective devices may be replaced by visual and audible alarms upon agreement with the *Register*.

No overload protection or alarm is required for measuring transformers and supply transformers for the control circuits.

8.5.2 Where transformers are intended for parallel operation, the switches capable of disconnecting their primaries and secondary but not necessarily simultaneously, shall be installed.

Where such transformers are fed from different sections of main switchboard, provision shall be made for interruption of parallel operation in case the sections from which the transformers are fed, are separated.

8.5.3 The switching-over of instrument current transformers shall be so arranged as to prevent the possibility of their secondary windings remaining open.

8.6 PROTECTION OF ACCUMULATOR BATTERIES

8.6.1 Accumulator batteries, other than those intended for starting of internal combustion engines, shall be provided with short-circuit current protection.

8.6.2 In case the conductors from the battery to motor starter are not protected from short-circuit current and overload, they shall be so selected and installed to be safe from short-circuits and earth connections.

8.6.3 Each battery charging system, shall be provided with protection against battery discharge due to voltage drop or loss of the charger output voltage.

8.7 PROTECTION OF SIGNAL LAMPS, VOLTMETERS, CAPACITORS AND VOLTAGE COILS IN DEVICES

8.7.1 Signal lamps as well as measuring and recording instruments shall be provided with short-circuit protection or short-circuit current limiting devices.

Signal lamps need not be provided with their own protection on condition that:

- .1 the lamps are enclosed together with the device;
- .2 the lamps are supplied from circuits inside the enclosure of the device;
- .3 the protection of the circuit of the device is rated for current not exceeding 25 A.
- .4 damage in the lamp circuit shall not cause interruption in the operation of essential service.
- .5 if connected to their own transformer

Short-circuit protection or current limiting devices shall be located as close as practicable to the terminals on the supply side.

8.7.2 Radio protection suppression capacitors installed in the circuits of main and emergency switchboards, generators and essential service electrical devices, shall be protected against short-circuit currents.

8.7.3 The voltage coils of apparatus and devices for control and protection shall be protected against short-circuit current, but they may have no protection of their own, provided that the conditions specified below are met:

- .1 the coils are enclosed with the device, are under overall protection and belong to the control system of one device;
- .2 the coils are supplied from the supply feeder of that device the protection of which is rated for current not exceeding 25 A.

8.8 PROTECTION OF POWER SEMICONDUCTOR UNITS

8.8.1 Provision shall be made for protecting power semiconductor units from internal and external overvoltages.

8.8.2 Semiconductor element units shall be protected against short circuit.

The diodes and thyristors protective devices shall be separated from the protective devices of power circuits.

8.8.3 Where only one consumer is foreseen, a common overload protection is permitted for diode and thyristor units and power circuits.

8.9 PROTECTION ARRANGEMENTS FOR HARMONIC FILTERS

8.9.1 Arrangements are to be provided to alert the crew in the event of activation of the protection of a harmonic filter circuit.

A harmonic filter should be arranged as a three phase unit with individual protection of each phase. The activation of the protection arrangement in a single phase shall result in automatic disconnection of the complete filter. Additionally, there shall be installed a current unbalance detection system independent of the overcurrent protection alerting the crew in case of current unbalance.

Consideration is to be given to additional protection for the individual capacitor element as e.g. relief valve or overpressure disconnecter in order to protect against damage from rupturing. This consideration should take into account the type of capacitors used.

9 EMERGENCY SOURCE OF ELECTRICAL POWER

9.1 GENERAL REQUIREMENTS

9.1.1 In each self-propelled ship, provision shall be made for an emergency source of electrical power.

The installation of an emergency source of electrical power in non-self-propelled ships is subject to the special consideration in each particular case and approval by the *Register*.

9.1.2 A diesel-generator or an accumulator battery may be used as an emergency source of power.

9.1.3 The capacity of the emergency source of power shall be sufficient to supply simultaneously all those consumers that are essential for the safety of navigation in an emergency.

9.1.4 Facilities shall be provided for testing the preparedness of the complete emergency installation, including testing of automatic starting arrangements of the diesel generator.

9.1.5 An indicator shall be mounted in the main control station or on the main switchboard to show when the battery which serves as an emergency source of electrical power is being discharged.

9.1.6 The emergency source of electrical power shall be provided only with short-circuit protection. If the emergency source of power is a diesel generator, visual and audible alarms shall be fitted in the main control station and emergency switchboard to warn of the generator overload.

9.1.7 The emergency generator may be used exceptionally, while the ship is at sea and for short periods, to supply non-emergency circuits for cases such as:

- .1 black out condition,
- .2 dead ship condition,
- .3 routine use for testing,
- .4 short term parallel operation with the main source of electrical power for purpose of load transfer.

9.1.8 If the emergency generator used during lay time in port for the supply of the ship mains, provided the requirements as per item 9.1.8.1 to 9.1.8.5 are complied with.

The remaining requirement in the case is stated in the *Rules for the classification of ships, Part 9 – Machines*, 2.15.4.

- .1 To prevent the generator or its prime mover from becoming overloaded when used in port, arrangements are to be provided to shed sufficient non-emergency loads to ensure its continued safe operation.
- .2 Fire detectors are to be installed in the location where the emergency generator set and emergency switchboard are installed.
- .3 Means are to be provided to readily change over to emergency operation.
- .4 Control, monitoring and supply circuits, for the purpose of the use of the emergen-

cy generator in port are to be arranged and protected that any electrical fault will not influence the operation of the main and emergency services.

- .5 Instruction is to be provided on board to ensure that when the vessel is under way all control devices (e.g. valves, switches) are in a correct position for the independent emergency operation of the emergency generator set and emergency switchboard.

9.1.9 On ships which the main electrical power source are as referred to in 3.1.2 emergency source of electrical power may be accumulator battery required in 3.1.2 with capacity requirement as imposed upon the emergency source of electrical power and location requirement as referred to in 13.2 and additional for passenger ships requirement that a fire or other causality occurring in the propulsion machinery space will not interfere with the supply or distribution of emergency power outside that space.

9.2 LOCATION OF EMERGENCY SOURCE OF ELECTRICAL POWER AND ASSOCIATED EQUIPMENT

9.2.1 Excepts as provided by 9.1.9 emergency source of electrical power and the associated transformers, if any, transitional source of emergency electrical power, emergency switchboard and emergency lighting switchboard, shall be located in spaces above the uppermost continuous deck, behind the collision bulkhead and outside the machinery casings. Exits from these spaces shall be readily accessible and shall lead directly to the open deck where emergency source of electrical power is located.

9.2.2 Emergency electrical equipment as required in 9.2.1 shall be so arranged that in case of fire or another emergency in the machinery space of category A as well as in spaces with main source of electrical power, associated transformers (if any) and main switchboard, does not hamper the supply, control and distribution of emergency electrical power.

9.2.3 Spaces containing emergency sources of electrical power and equipment required in 9.2.1 shall not, where possible, be adjacent to machinery and boiler spaces or to spaces containing the main sources of electrical power, transformers and main switchboards. In case of adjacent arrangement, the decks and bulkheads separating these spaces shall be constructed in accordance with the requirements of the *Rules for the classification of ships, Part 17 - Fire Protection* relating to control consoles.

9.2.4 Emergency switchboard shall be as close as possible to the emergency source of power.

9.2.5 Where a diesel generator is an emergency source of electrical power, emergency switchboard shall be installed in the same space as the diesel generator, except where such an arrangement would adversely affect the switchboard operation.

All starting arrangements, charging facilities and starter accumulator batteries of the emergency unit shall also be installed in this space provided the requirements of 1.3.2 are complied with.

9.2.6 The emergency generator space shall be provided with heating appliance to ensure the temperature in the space sufficient for safe starting of diesel generator as well as ventilation in accordance with the *Rules for the classification of ships, Part 8. - Piping-7.5.3.*

9.2.7 Where the emergency source of electrical power is an accumulator battery, the emergency switchboard shall be installed in separate space. The requirements for the battery compartments are given in 13.2.

9.3 EMERGENCY SOURCE OF ELECTRICAL POWER IN CARGO SHIPS

9.3.1 In cargo ships area of navigation 1 and area of navigation 2, with 300 GT and upwards, the emergency source of electrical power shall supply the services listed below for a period of 18 hrs.:

- .1 emergency lighting:
 - .1 in corridors, stairways, exits from accommodations and service spaces, passenger elevators cabins and their trunks;
 - .2 in machinery spaces and main sources of electrical power;
 - .3 in all control stations, main and emergency switchboards;
 - .4 in the space of emergency source of electrical power;
 - .5 on navigation bridge;
 - .6 in the chartroom and radio room;
 - .7 in stowage locations for emergency and fireman's outfit and manual fire extinguishers;
 - .8 in steering gear compartments;
 - .9 at fire and sprinkler pumps, emergency bilge pump with control locations of their motors;
 - .10 in helicopter hangars and landing areas;
 - .11 in gyrocompass space;
 - .12 in medical spaces.
- .2 navigation lanterns, signal lights and other lights required by the Regulations for Preventing Collisions at Sea;
- .3 internal communication means, general alarm signal and public address system.
- .4 radio equipment in accordance with the SOLAS 74, Ch. IV and navigational equipment in accordance with the SOLAS 74, Ch. V;
- .5 fire detection and alarm system;
- .6 daylight signalling lamps, sound signal means, manual loud speaker and other signals required in emergency conditions;
- .7 fire pumps supplied by the emergency source of electrical power and electrical equipment which ensures the operation of foam generators referred to in the *Rules for the classification of ships, Part 17. - Fire Protection - 3.8.3.7.*
- .8 tanker cargo pumps room;

- .9 other systems which are found necessary by the *Register* to ensure safety of the ship and the persons on board.

Consumers mentioned in 9.3.1.3 to 9.3.1.6 may be supplied from their own batteries arranged in accordance with 9.2 having a capacity sufficient to supply these consumers during 18 hours.

For ships of restricted areas of navigation 3, 4, 5, 6, 7, 8 with a gross tonnage of 300 GT and over, the period of 18 hours may be reduced to 12 hours.

For ships of less than 300 GT of unrestricted area of navigation 1 and area of navigation 2 great coastal service, the period of 18 hours may be changed to 6 hours and for restricted areas of navigation 3, 4, 5, 6, 7, 8, to 3 hours.

9.3.2 Emergency source of electrical power shall ensure the supply of lighting of embarkation exits into the life-saving appliances as well as of the deck surrounding during 3 hours in accordance with the Reg. 11 and 16, Ch. III SOLAS 74 as amended.

9.3.3 Emergency source of electrical power shall ensure the supply of the steering gear electrical equipment in accordance with 5.5.6.

9.3.4 Where a diesel generator is an emergency source of electrical power, it shall be:

- .1 driven by an internal combustion engine in accordance with the *Rules for the classification of ships, Part 9. - Machines 2.2.6 and 2.11.3.4 and Part 7 - Machinery installation, 1.6.2.1;*
- .2 be automatically connected to emergency switchboard in case of voltage loss on main switchboard busbars, and completely take-over the supply of consumers referred to in 9.3.1 within the period not exceeding 45 seconds from the starting of generator.
- .3 provided a transitional source of electrical power, if the condition of taking-over of total load within 45 seconds is not fulfilled.

9.3.5 Where an accumulator battery is used as the emergency source of electrical power, it shall:

- .1 withstand full load during the discharge period without recharging, with voltage drop on the terminals not lower than 12 percent of battery rated voltage;
- .2 be automatically connected to emergency switchboard busbars in case of voltage loss on the main switchboard busbars and supply at least the consumers mentioned in 9.3.7.

9.3.6 As transitional source of emergency electrical power referred to in 9.3.4.3, an accumulator battery shall be used which shall sustain the full load during the whole discharge period with voltage drop at the terminals which shall not exceed 12 percent of rated voltage.

9.3.7 The capacity of the battery serving as the transitional source of electrical power shall be sufficient to supply, during 30 min, the following consumers:

- .1 lighting and navigational lights according to 9.3.1.1, 9.3.1.2 and 9.3.2;

- .2 all internal communications and public address systems required in an emergency;
- .3 general alarm system and fire detection and alarm system;
- .4 daylight signalling lights and sound signals.

When the consumers referred to in .2, .3, and .4 are provided with their own accumulator batteries which supply them during the required period of time, they need not be supplied from the transitional source of power.

9.3.8 Where the emergency and/or transitional emergency loads are supplied from a battery via an electronic converter the maximum permitted d.c. voltage variations are to be taken as those the load side of the converter or inverter.

Where the d.c. converted into a.c. the maximum variation are not exceed those given in 2.1.

9.4 DISTRIBUTION OF ELECTRICAL POWER FROM EMERGENCY SOURCE

9.4.1 Emergency switchboard, under normal service conditions, shall be supplied from the main switchboard by a supply feeder which shall be provided with an overload and short-circuit protection fitted at the main switchboard.

The emergency switchboard shall be fitted with a switch which in case of the voltage loss on the main switchboard busbars, will automatically switch-off the feeder.

Where the main switchboard shall be supplied from the emergency switchboard, the automatic switch at the emergency switchboard shall be provided with at least short circuit protection.

9.4.2 When, exceptionally, an emergency source of power is intended to supply for short-time less essential consumers:

- provisions shall be made to ensure the function of the emergency consumers under any emergency conditions;
- automatic disconnection of less essential consumers from the emergency switchboard if necessary to ensure the supply of emergency consumers, shall be provided.

9.4.3 Consumers mentioned in 9.3.1 and 19.1.2 shall be supplied through separate feeders from the emergency switchboard fitted up with relevant switching and protection devices. The consumers mentioned in 9.3.1.2 to 9.3.1.6 and 19.1.2.1.2 to 19.1.2.1.6 may be supplied from the main control console on the navigating bridge supplied in accordance with 4.5.2.

9.4.4 Where a transitional source of power is available, consumers referred to in 9.3.7 and 19.1.2.7 shall be supplied through a special switchboard on which switching devices need not be fitted.

9.4.5 Cables supplying emergency consumers shall be so laid that in case of flooding of the spaces below the bulkhead deck where the consumers are located, supplying of the consumers located above this deck is not impaired.

9.4.6 Distribution boards for the emergency consumers supply shall not be installed below the freeboard deck.

9.4.7 For ships where electrical power is necessary to restore propulsion, the capacity shall be sufficient to restore propulsion to the ship in conjunction with other machinery, as appropriate, from a dead ship condition with 30 min. after black out.

“Dead ship” condition, for the purpose of this item, is to be understood to mean a condition under which the main propulsion plant, boilers and auxiliaries are not in operation and in restoring of propulsion, no stored energy for starting the propulsion plant, the main source of electrical power and other essential auxiliaries is to be assumed available. It is assumed that means are available to start the emergency generator at all time.

The emergency generator and other means needed to restore the propulsion are to have a capacity such that the necessary propulsion starting energy is available within 30 minutes of blackout/dead ship condition as defined above. Emergency generator stored starting energy is not to be directly used for starting the propulsion plant, the main source of electrical power and/or other essential auxiliaries (emergency generator excluded).

For steam ships, the 30 minute time can be interpreted as time from black out / dead ship condition defined above to light-off of the first boiler.

9.5 STARTING ARRANGEMENTS FOR EMERGENCY DIESEL GENERATORS

9.5.1 The following arrangements may be used as starting arrangements:

- .1 electrical starter with its own accumulator battery and charging device;
- .2 compressed air system with its own independent air receiver;
- .3 hydraulic starting system;
- .4 manual starting arrangements and devices, such as:
 - handle for manual starting;
 - inertia starting;
 - manually charged hydraulically accumulators;
 - powder charged cartridges;

9.5.2 Each emergency diesel generating set arranged to be automatically started as mentioned in 9.3.4.2 shall be equipped with a starting system approved by the *Register* with a stored energy capable of at least three consecutive starts.

Another source of energy shall be provided for additional three starts within 30 min. unless manual starting is affected.

9.5.3 Where automatic starting of the emergency diesel generator is not required, manual starting may be effected in accordance with 9.5.1.4.

When manual starting is not possible, the starting arrangements shall comply with the requirements in 9.5.2.

9.5.4 Where the starting arrangement is only the electrical starter with its own accumulator battery, another accumulator battery with a stored energy according to 9.5.2 shall be ensured.

9.5.5 The starting arrangements of the accumulator batteries referred to in 9.5.2 and 9.5.4 as well as the electrical drives of the compressed air and hydraulically systems of

starting shall be supplied by separate feeders from the emergency switchboard.

Alarm of battery charger device failure shall be provided on central control position.

9.5.6 Emergency generators shall be capable of being readily started in their cold conditions down to a temperature of 0°C. If this impracticable, or if lower temperatures are likely to be encountered, consideration is to be given to the provision and maintenance of heating arrangements, so that ready starting will be assured.

10 ELECTRICAL ROTATING MACHINES

10.1 GENERAL

10.1.1 The materials of propelling machinery and generator shafts as well as couplings being component parts of the shafting, shall comply with the *Rules for the classification of ships, Part 7. - Machinery Installation, 1.3.2.*

10.1.2 Alternating-current generators rated above 50 kVA, including their excitation systems and automatic voltage regulators shall be capable of withstanding in short circuit, three times the rated current for 2 secs.

10.1.3 Generators and electrical motors being part of electrical propulsion plant and, where justified, also other machines, shall be provided with heating arrangements to maintain their temperature at least 3°C above the ambient air temperature.

10.1.4 Shaft generators built into the shafting of the main machinery, shall have separated stators and bearing shields, if due to the shaft arrangement, the stator displacement in the direction of the shaft from the rotor is not possible.

Such generators shall have an air gap preventing mechanical contact of the rotor and stator under the most unfavourable service conditions.

10.1.5 Testing of electrical rotating machines, type and routine, shall be carried out regarding to IACS Unified Requirement E13 - Test requirements for Rotating Machines.

10.1.6 Where a machine is so designed that after installation on board its bottom portion is positioned below flooring level, the ventilation air intake shall be fitted above the flooring.

10.1.7 Machines intended to be installed on the open deck are not recommended to be cooled by external air.

10.2 SLIP RINGS, COMMUTATORS AND BRUSHES

10.2.1 Direct-current machines over 200 kW/kVA as well as direct-current machines being part of the propulsion plant, irrespective of their power, shall be provided with sight holes to enable observation of the commutator and brushes without removing the lids.

10.2.2 The permissible wear of commutator blades or slip rings shall be indicated on their outer front sides.

10.2.3 For rotors more than 1.000 kg in mass, provision shall be made for reconditioning of the commutator without removing the rotor from the machine.

10.2.4 A flexible copper conductor shall be used for drawing current from brushes. Brush holder springs shall not be used for this purpose.

10.2.5 The position of brushes in direct-current machines shall be clearly and indelibly marked and the machines

shall be so designed that they can work with fixed brush setting under all conditions.

10.2.6 Commutator type machines shall be capable of operating without sparking at any load from zero to rated value.

No sparking shall be possible at the permissible overloads, reversals or start-up to such an extent as to cause damage to brushes or commutators.

10.3 BEARINGS

10.3.1 Bearings shall be so designed as to avoid oil splashing or leaking along the shaft and penetrating in the machine windings or live parts.

10.3.2 The casings of the sliding bearings shall be fitted with a hole for excessive lubricating oil overflow and with a lid in the upper part of the casing. Oil level indicators should be provided on the machines rated over 100 kW/kVA.

10.3.3 Pressure lubricating system shall incorporate pressure indicators for oil at the bearing inlet.

10.3.4 Provisions shall be made to prevent flow of creepage currents through sliding friction bearings of electrical propulsion machines and where justified of other machines, too.

10.3.5 Generators driven by belts or chains by the main propulsion engine shall be so designed to withstand the effect of lateral forces.

10.4 TEMPERATURE TRANSMITTERS

10.4.1 Stators of the alternating-current machines rated at over 5.000 kW/kVA or with active core length of more than 1.000 mm, shall be provided with temperature indicators installed, where the machine may be expected to develop the highest temperature.

10.4.2 Embedded temperature transmitters are recommended for electrical motors in short-time or intermittent operating conditions.

10.5 OVERLOAD CONDITION

10.5.1 Generators shall be so designed that after reaching the steady-state temperature corresponding to the rated load, they should be capable sustaining overcurrent in accordance with the Table 10.5.1.

Table 10.5.1

No.	Kind of generator	Overcurrent %	Duration of overload, sec.
1	alternating	50	120
2	direct-current	50	15

10.5.2 Electrical motors shall be so designed that they are capable of developing without stopping, the increased torque specified in Table 10.5.2.

10.6 ALTERNATING CURRENT GENERATORS

10.6.1 General requirements

10.6.1.2 Each alternating-current generator shall have a separate, independent system for automatic voltage regulation.

10.6.1.3 Failure in the automatic voltage regulation system of the generator shall not cause inadmissible rise of voltage at its terminals.

10.6.1.4 Protection of alternating-current generators shall comply with the requirements of 8.2.

10.6.2 Voltage regulation system

10.6.2.1 Alternating-current generators shall have voltage regulation system so adapted to the regulation characteristics of the prime movers, that rated voltage may be maintained within $\pm 2,5$ percent (emergency generator up to $\pm 3,5$ percent) at all load changes from no-load to rated load values, at rated power factor.

Main generators may have their voltage maintained within $\pm 3,5$ percent of the rated value at all power factor values from 0,6 to 0,9, excluding the rated power factor.

The above requirement is applicable if prime mover is operating at rated speed of rotation and generator rated load.

10.6.2.2 A sudden change of the symmetrical load of a generator running at rated speed and rated voltage, under given current and power-factor conditions, shall not cause voltage

drop below 85 percent of the rated value or a rise above 120 percent.

After such a change, the generator voltage shall be restored within not more than 1,5 sec. to ± 3 percent of the rated value. For emergency sets these values may be increased, respectively, to 5 sec. and ± 4 percent of the rated voltage.

Where no precise data are available on peak values of sudden load that may occur additionally to the existing generator load, these may be taken equal to a load of 60 percent of the rated current at an inductive power factor of 0,4 or less which is connected at idle speed and then disconnected.

10.7 DIRECT-CURRENT GENERATORS

10.7.1 General requirements

10.7.1.1 Direct-current generators with parallel excitation shall be equipped with automatic voltage regulators.

10.7.1.2 Protection of direct-current generators shall comply with the requirements of 8.2.

10.7.2 Voltage regulation

10.7.2.1 Voltage regulators of compound-wound generators shall enable reduction of no-load voltage with the generator cold, by not less than 10 percent below the rated generator voltage taking into account the increased speed of the prime mover running at no load.

Table 10.5.2

No.	Motor type	Torque increase %	Duration of over-load sec.	Testing conditions
1	2	3	4	5
1	Poliphase synchronous motors as well as squirrel-cage motors with starting current less than 4,5 times the rated current	50	15	Frequency, voltage and excitation to be maintained at rated levels
2	Asynchronous motors for continuous and intermittent service	60	15	Frequency and voltage to be maintained at rated levels
3	Motors as specified in item 2, but for short-time and continuous service with varying load.	100	15	As under 2.
4	Direct-current motors	50	15	Voltage to be maintained at rated level

10.7.2.2 Manual voltage regulators shall be so designed, that the voltage increases when their controls are rotated clockwise.

10.7.2.3 Voltage regulators of generators with parallel-excitation shall be so designed that, when the field current is removed, the field winding is automatically connected to the discharge circuit.

10.7.2.4 Compound-wound generators shall have independent devices for voltage regulation within a tolerance of \pm

1 percent for generators rated up to 100 kW, or within $\pm 0,5$ percent for generators exceeding 100 kW.

The above regulation limits shall be maintained with the generator cold and hot at any load within the operating load range of generators.

10.7.2.5 Direct-current sets comprising compound-wound generators shall have such external characteristic, that the voltage of a hot generator adjusted to the rated value with an accuracy of ± 1 percent at 20 percent of the load, does not vary at full load by more than $\pm 1,5$ percent for generators rat-

ed at 50 kW or over, and by more than $\pm 2,5$ percent for generators with lower output.

Voltage variations in a compound-wound generator running at 20 to 100 percent of the rated load shall not exceed the following limits:

- .1 ± 3 percent for generators rated at 50 kW and more;
- .2 ± 4 percent for generators rated over 15 kW but not more than 50 kW;
- .3 ± 5 percent for generators rated at up to 15 kW.

10.7.2.6 Direct-current sets comprising generators with parallel-excitation shall have such external generator characteristic and automatic voltage regulation that voltage is maintained within $\pm 2,5$ percent of the rated value at all load variations from zero to the rated load.

10.8 ELECTROMAGNETIC BRAKES

10.8.1 The brake shall operate when the break operating coil becomes de-energised.

10.8.2 A 30 percent voltage drop below the rated value shall not cause a hot brake to operate.

10.8.3 Electromagnetic brake shall be released manually after being activated.

10.8.4 Electromagnetic brake shall be fitted with at least two pressure springs.

10.8.5 The windings of the brake parallel excitation with the compound excitation shall be capable of holding off the brake even when no current flows through the series winding.

10.8.6 The windings of the brake parallel excitation shall be so constructed, or protected, that they are safe from damage at overvoltages which occur when they are disconnected (see 5.4.3).

11 TRANSFORMERS

11.1 GENERAL PROVISIONS

The requirements of this part of the Rules apply to power and lighting transformers referred to in 3.3.

Additional requirements for transformers with voltages over 1.000 V are set forth in 18.8.

11.2 GENERAL REQUIREMENTS

11.2.1 Dry-type transformers shall be used only. The use and arrangement of other types of transformers shall be subject to special consideration of the *Register* in each particular case.

11.2.2 Primary and secondary windings of transformer shall be electrically separated.

11.3 OVERLOAD, VOLTAGE VARIATION AND RUNNING IN PARALLEL

11.3.1 Transformers shall be so constructed as to be capable of withstanding at least 10 percent overload for 1 hour and 50 percent overload for 5 min.

11.3.2 Voltage variation at any active load between zero and rated load shall not exceed 5 percent for transformers rated at up to 6,3 kVA per phase and 2,5 percent for transformers of higher rating.

11.3.3 Transformers intended for operation in parallel shall have connection groups adjusted to each other and equal transforming ratio and their short circuit voltages shall be such that the load on any transformer does not depart from the corresponding proportional part of power output by more than 10 percent of the rated current of each transformer.

11.3.4 The rated power of the smallest transformer operating in parallel, shall not be less than half the rated power of the largest in the group.

11.3.5 Scope and testing conditions of power and lighting transformers are referred to in Work instruction QW58 of the *Register* (available upon request).

12 POWER SEMICONDUCTOR UNITS

12.1 GENERAL REQUIREMENTS

12.1.1 Semiconductor elements of silicon type shall be used in power semiconductor units, only.

Elements of other type are permitted on special agreement with *Register*.

12.1.2 To prevent condensation in semiconductor units having the dissipation power above 500 W, provision shall be made for heating so that their temperature is at least by 3°C higher than that of the ambient air.

12.1.3 Power semiconductor units shall be air cooled (naturally or forced).

Liquid cooling shall be permitted only on special agreement with the *Register*.

12.1.4 Power semiconductor units with forced cooling shall be fitted with the protection reducing or disconnecting the load in case of ventilation stop.

Activating of protection shall be indicated by visual and audible signalling.

12.2 PERMISSIBLE PARAMETERS OF VOLTAGE DISTORTION

12.2.1 The non-linear distortion factor K_u for the ship's network caused by the operation of the power semiconductor units shall not exceed 8 percent.

The power semiconductor units which cause the sine distortion of the voltage curve above the specified limits are subject to special consideration by the *Register*.

The non-linear distortion factor K_u shall be determined from the formula:

$$K_u = \frac{1}{U_c} \sqrt{\sum_{n=2}^{200} U_n^2} \cdot 100\%$$

where:

- U_c – effective value of the network voltage;
- U_n – effective value of voltage of n-number harmonic;
- n – number of higher harmonic

12.2.2 The maximum relative deviation of instantaneous voltage value from the first harmonic value ΔU_N shall not exceed 30 percent.

Factor ΔU_N shall be determined from the formula:

$$\Delta U_N = \frac{\Delta U_m}{\sqrt{2} U_1} \cdot 100\%$$

where:

- ΔU_m – maximum deviation value;
- U_1 – effective value of the first harmonic of the voltage

Voltage drop of the ship's network distorted voltage shall not exceed the values:

- amplitude of voltage drop
 $\Delta U \leq 30$ percent at $t_B \leq 0,5$ ms
- voltage drop duration
 $t_B \leq 0,8$ ms at $\Delta U \leq 20$ percent

Exceptionally, the *Register* may agree on higher values.

12.3 CONTROL AND SIGNALLING SYSTEMS

12.3.1 Semiconductor arrangements shall be provided with light signals indicating switching on or off of power and control circuits.

12.3.2 The power circuits shall be electrically separated from the control systems

12.3.3 The long-term current deviation in the parallel branches of semiconductor arrangements shall not exceed 10 percent of average current value.

12.3.4 The operation of semiconductor arrangements shall not be hampered by the failure of particular semiconductor valves.

When the load of particular valves exceeds permissible values, it shall be reduced automatically.

The failure of the valves in service shall be indicated by visual and audible signals.

12.3.5 The angle displacement of semiconductor control systems pulse ($\Delta\alpha$) shall be determined from the formula:

$$\Delta\alpha = \delta_k - \frac{360}{n}$$

where:

- δ_k – time interval between the pulses of adjacent channels in electrical degrees;
- n – number of control channels

The angle displacement shall not exceed ± 3 electrical degrees at any point of regulated range

13 ACCUMULATOR BATTERIES

13.1 GENERAL REQUIREMENTS

13.1.1 Accumulator batteries shall be so constructed that the loss of capacity of a fully charged battery due to self-discharge after 28 days of being stored at a temperature of $25 \pm 5^\circ\text{C}$ does not exceed 30 percent of rated capacity for acid batteries and 25 percent for alkaline batteries.

13.1.2 Battery containers and hole pins shall be so constructed as to prevent spilling or splashing of the electrolyte when the container is inclined on any side to an angle of 40° from the vertical.

Pins shall be made from durable material resistant to electrolyte.

Pins design shall not allow building up of excessive gas pressure inside the battery.

13.1.3 The mastics used shall not change their properties or deteriorate at ambient temperature changes within -30 to $+60^\circ\text{C}$.

13.1.4 Material used to fabricate crate to house battery cells shall be resistant to electrolyte.

Individual cells arranged within the crates shall be so secured as to avoid the relative movement between them.

13.2 ARRANGEMENT

13.2.1 Batteries having a voltage in excess of the safety voltage, as well as batteries having a capacity over 2 kW, computed from the maximum charging current and the rated voltage, shall be located in special battery compartments accessible from the open deck or in appropriate boxes installed on open deck. These spaces shall be considered to be special electrical spaces.

Batteries having charge capacity between 0,2 kW and 2 kW may be installed in boxes or cabinets located inside the ship's hull.

In ships with low power electrical installation, the batteries may be installed in the machinery space provided that their upper sections are at least above the highest line of submerging in case the ship is flooded, or it shall be assured in another way, that the flooding will not cause the short-circuit connection.

Batteries intended for the electrical starting of internal combustion engines except those for emergency units may be installed in machinery spaces in special cabinets or boxes with sufficient ventilation.

Batteries having capacity less than 0,2 kW may be installed in any space other than accommodation spaces, provided they are protected from the water action and mechanical damage and do not harmfully affect the surrounding equipment.

13.2.2 The acid and alkaline batteries shall not be installed in one compartment or in one box. Vessels and instruments intended for the batteries with different electrolytes shall be stored separately.

13.2.3 The inside part of a battery compartments or cabinets, as well as all structural parts, which may be exposed to harmful effects of electrolyte or gas shall be suitably protected.

13.2.4 The accumulator batteries and their cells shall be properly fixed. In case they are installed on shelves, the distance from the deck to the pins in the upper row of cells shall not exceed 1500 mm.

13.2.5 The fitting linings and spacers shall be provided between accumulator batteries or individual cells to ensure clearance for circulation of air of not less than 15 mm on all sides.

13.2.6 Warning notices indicating the danger of explosion shall be fitted on the doors leading to the battery compartments and on boxes and cabinets containing the accumulators.

13.3 HEATING

13.3.1 The battery compartments, boxes and cabinets wherein the temperature during the operation may fall down below $+5^\circ\text{C}$ shall be heated. The compartments, boxes and cabinets may be heated either by the heat from adjacent spaces or with water or steam radiators located inside them.

13.3.2 The heating system valves shall be located outside the battery compartments.

13.3.3 The ship's air conditioning system shall not be used for heating the battery compartments.

13.4 VENTILATION

13.4.1 The battery compartments, boxes and cabinets shall be sufficiently ventilated to prevent accumulation of explosive mixtures. The ventilation system shall comply with the requirements of the *Rules for the classification of ships, Part 8. - Piping*, 7.10.

13.4.2 The battery compartments with forced ventilation shall be fitted with interlocking devices which prevent charging of accumulator batteries in case the ventilation is switched off or cut-out charging if the ventilation stops during charging operation.

13.5 CHARGING OF BATTERIES

13.5.1 Charging facility shall be provided to fully charge the discharged accumulator battery intended for essential services within 8 hours.

In case the additional battery is provided which substitutes that being charged, the charging time may exceed 8 hours.

13.5.2 The charging facilities shall have means for measuring the voltage across battery terminals and charging current, and in addition discharging current, if the battery is emergency source of electrical power.

13.5.3 In ships equipped with portable accumulator-fed lamps or with spare accumulator fed signal and navigational lights the facilities shall be provided for charging their accumulator batteries.

13.5.4 The requirements which apply to the accumulator protection are set forth in 8.6.

13.6 INSTALLATION OF ELECTRICAL EQUIPMENT

13.6.1 Only explosion-protected lamps, switches, fan motors and space-heating appliances shall be installed in battery rooms. The following minimum requirements are to be observed:

- Explosion group II C
- Temperature class T 1

Other electrical facilities are permitted only with the special approval of CRS.

13.7 ELECTRICAL STARTING OF INTERNAL COMBUSTION ENGINES

13.7.1 Number of starting batteries

13.7.1.1 In ships equipped with electrically-started internal combustion engines, irrespective of the number of such engines, not less than two starting batteries shall be permanently installed for starting each of the main and auxiliary engines, or not less than two common batteries for starting all the engines. Provision shall be made for a change-over switch that will ensure the use of any battery for starting any of the engines in the group serviced by these batteries.

These batteries shall not be connected in parallel.

13.7.1.2 For ships of restricted area of navigation 4, 5, 6, 7, 8 as well as for ships with the low power electrical installation and the restricted area of navigation 3 (except passenger ships), only one starting accumulator battery may be used for starting all the engines.

13.7.2 Battery selection

13.7.2.1 Each starting battery shall be designed for discharging current that corresponds to the maximum current of the most powerful electric motor to be started.

13.7.2.2 Capacity of each battery shall be sufficient without recharging to provide within 30 min., for 6 subsequent starts of the engine in the ready-for-start condition or in case of two or more engines, for not less than three starts of each engine.

13.7.2.3 When calculating battery capacity, the duration of each start shall be considered not less than 5 sec.

13.7.3 Charging facilities

13.7.3.1 A starting battery charging facility shall be supplied by a separate feeder from the main switchboard even if the battery can be charged from the suspended alternator.

13.7.3.2 In ships of restricted area of navigation 4, 5, 6, 7, 8 as well as in ships with the low power electrical installation and restricted area of navigation 3 (except passenger ships), the starting battery may be charged only from the alternator.

13.8 SEALED BATTERIES

The use of such batteries will be, in each particular case, considered by the *Register*.

13.9 RECORDING OF THE TYPE, LOCATION AND MAINTENANCE CYCLE OF BATTERIES

13.9.1 Where batteries are fitted for use for essential and emergency services a schedule of such batteries is to be compiled and maintained. The schedule, which is to be reviewed by the *Register*, during plan approval or the newbuilding survey, is to include at least the following information regarding the battery(ies):

- Type and manufacturer's type designation.
- Voltage and ampere-hour rating.
- Location.
- Equipment and/or system(s) served.
- Maintenance/replacement cycle dates.
- Date(s) of last maintenance and/or replacement.
- For replacement batteries in storage, the date of manufacture and shelf life.

13.9.2 Procedures are to be put in place to ensure that where batteries are replaced that they are of an equivalent performance type.

13.9.3 Where vented type batteries replace valve-regulated sealed types, it is to be ensured that there is adequate ventilation according to *Rules for the classification of ships, Part 8 Piping*, item 7.10.

13.9.4 Details of the schedule and of the procedures are to be included in the ship's safety management system and be integrated into the ship's operational maintenance routine as appropriate to be verified by the *Register*' surveyor.

14 SWITCHING DEVICES AND INSTALLATION MATERIAL

14.1 SWITCHING DEVICES

14.1.1 General requirements

14.1.1.1 Switching devices provided with replaceable contacts shall be such that the replacement of contacts is possible by means of standard tools without dismantling switching device or its basic components.

14.1.1.2 All switching devices, except those for cabins, shall be provided with mechanical or electrical contact-position indicators located where the switching device is actuated from.

14.1.1.3 The change of position of the controller switching device drums shall be clearly felled in each position, the zero position more than other positions. The drums shall be fitted with a scale and indicator or the position indicating device.

14.1.1.4 Switching devices for starting and regulation, other than those for continuous regulation, shall be so constructed that the end and intermediate positions are easy to feel while the movement beyond the end positions shall be impossible.

14.1.2 Manually operated switching devices

14.1.2.1 The direction of movement of handles or hand wheels of the control, starting and regulation switching devices shall be such that clock wise rotation of a hand wheel or shifting of a handle upwards or forwards correspond to closing of a switching device, start-up of a motor, increased speed, increased voltage etc.

Where lifting or lowering mechanisms are considered, clockwise rotation of a handwheel or shifting of a handle toward oneself shall correspond to lifting movement and counter-clockwise rotation or shifting away from the operator to the lowering movement.

14.1.2.2 Switching device push buttons shall be so designed that they cannot be actuated accidentally.

14.1.3 Motor-operated switching devices

14.1.3.1 Actuators of automatic and other switching devices shall be so constructed that in the event of loss of supply to the actuating motor, switching contacts remain in open or in closed position depending on their positions at the moment of loss of supply.

14.1.3.2 Electrical motor actuator shall ensure the correct closing of switching device under all load conditions and within voltage limits between 85 and 110 percent of the rated value for direct current and in case of alternating current, at rated frequency, also.

14.1.3.3 Actuator operation at 110 percent of the rated control voltage shall not cause mechanical damage of a

switching device or excessive wearing of contacts liable to affect the switching capacity (due to arcing or welding of contacts).

For electromagnetic contractor, this requirement is applicable to contact operation at an ambient temperature of -10°C and with the coil winding cold.

14.1.3.4 Actuator operation at 85 percent of the rated control voltage shall ensure correct closing of a switching device at rated current and at an ambient temperature of +45°C with the actuator winding hot.

14.1.3.5 Actuator operation at 70 percent of the rated control voltage shall not cause separating of movable elements or pressure reduction between them below the minimum permissible at the ambient temperature of +45°C and with the actuator winding hot.

14.1.3.6 Each motor-actuated switching device shall be fitted with manual control, also.

14.1.4 Coils

14.1.4.1 The supply cable or a cable shoe shall be so attached to a coil winding as to avoid mechanical stresses of the connection affecting the coil turns.

The tapings of voltage coils shall be made from flexible stranded conductor, except where the contact terminals are secured directly to the coil frame.

14.1.4.2 The coils of electromagnetic apparatus shall bear notations with their technical data.

14.1.5 Resistor elements

14.1.5.1 Resistor elements shall be easily replaceable, either in sections or in total.

14.1.5.2 Resistors shall be so disposed and ventilated that they do not heat other devices above permissible temperature.

14.1.5.3 The joints between the resistor elements or between them and terminals, if no dismantling is anticipated, shall be welded or mechanically press-fitted.

They may be soldered only where there is no risk of temperature rise at the function joint above the limits required for the solder.

14.1.6 Fuses

14.1.6.1 Housings of melting cartridges shall be of the totally enclosed type and shall allow no arc ejection to the outside, sparking or other harmful effect upon the adjacent parts of the equipment.

14.1.6.2 Melting cartridges shall be made from non-combustible and non-hygrosopic insulating material.

14.2 ELECTRICAL ACCESSORIES

14.2.1 General requirements

14.2.1.1 The enclosures of fixed accessories and fittings shall be constructed from at least flame-retardant material of

adequate mechanical strength and resistant to sea atmosphere and oil vapours or otherwise adequately protected.

The enclosures of accessories and fittings intended for installation on weather decks, in refrigerated cargo spaces, fish processing shops or other humid areas shall be made of metallic or plastic materials of adequate quality in accordance with the requirements of the *Rules for the classification of ships, Part 25. – Metallic Materials*.

These requirements shall be applicable if alloys are used. The use of threaded connections or tight-fit mating of parts in accessories made of aluminium alloys, is not allowed.

14.2.1.2 Insulating parts to which current-carrying components are fitted shall be made of materials which up to 500°C do not evolve gases, which might ignite electrically.

14.2.1.3 The lighting fixtures designed to be mounted on combustible materials or close to, shall not be heated above 90°C.

14.2.2 Lampholders

14.2.2.1 The lampholders fitted with screw caps shall be such as to prevent the lamp from getting loose in service.

14.2.2.2 No switches are allowed to be fitted in lampholders.

14.2.2.3 Each lighting lampholder shall be marked to indicate rated voltage and maximum allowable current or load.

14.2.3 Plug and socket connector

14.2.3.1 The pin jacks of socket outlets shall be so constructed as to ensure permanent pressure in contact with the plug pins.

14.2.3.2 Plugs with slotted pins are not allowed. The plug pins for currents in excess of 10 A shall be cylindrically shaped, solid or hollow.

14.2.3.3 Socket and plugs for the voltage exceeding the safety level shall have contacts for earthing conductors of the cables supplying the consumers.

14.2.3.4 Socket shall be so constructed as to ensure the required degree of mechanical protection regardless of whether the plug is in or out of the socket.

14.2.3.5 Socket rated at over 16A shall be provided with built-in switches.

Provision shall be made for interlocking such sockets to prevent the plug being inserted or withdrawn when the socket switch is in the switched-on position.

14.2.3.6 Where sockets are not interlocked as required in 14.2.3.5, air clearance between contacts and creepage distances shall be such that no short circuit is possible due to arcing when the plug is withdrawn while carrying 150 percent of the rated current at rated voltage.

14.2.3.7 Socket and plugs shall be so designed that it is not possible to insert only one live contact pin into the socket or insert a live contact pin into the earthing contact or to change the sequence of phases or poles in case the motor direction of rotation or the mode of operation of apparatus con-

nected to these socket depends on this sequence. When inserting the plug into the socket, the earthing part of the plug shall make contact with the earthing part of the socket before connecting the live pins.

14.2.3.8 In sockets, plugs and distribution boxes, no fuses shall be installed.

15 ELECTRICAL HEATING, AND PREHEATING APPLIANCES

15.1 GENERAL REQUIREMENTS

15.1.1 Only fixed type of electrical heating appliances shall be permitted for use.

15.1.2 Electrical heating and preheating appliances shall be supplied from the main switchboard or from distribution boards intended for this purpose and also from the lighting distribution boards complying with the requirements of 6.2.1.

15.1.3 The supporting structural parts of electrical heating appliances as well as the internal surfaces of enclosures, shall be manufactured from non-combustible materials.

15.1.4 Permissible current loss shall not exceed 1mA per 1 kW of rated power for each separately connected heating element or 10mA for the appliance as a whole.

15.1.5 Electrical heating and preheating appliances shall be so designed that the temperature of their components which are handled by the personnel or which can be touched inadvertently does not exceed the values indicated in Table 15.1.5.

15.2 HEATING APPLIANCES

15.2.1 Electrical heating appliances intended for space heating shall be fixed and provided with thermal fuses disconnecting the supply source when the temperature rise of the enclosure exceeds the permissible limit.

15.2.2 The heating appliances shall be installed in accordance with the requirements of the *Rules for the classification of ships, Part 17 - Fire protection, 2.1.11*.

15.2.3 If a switch is not built in the heating appliance, switching device shall be installed in the same room wherein this appliance is located. Switches shall disconnect simultaneously all poles or phases.

15.2.4 The enclosures of electrical heating appliances shall be so constructed as to prevent the possibility of any object being placed upon them.

15.2.5 The fixed heating appliances with rated voltage in accordance with Table 4.2.3, No. 1. and 2. respectively, shall have enclosures protected mechanically of such a degree that no access to live parts is possible without special tools. An indication plate shall be fitted on the enclosure bearing the notice of rated voltage.

15.2.6 Electrical cooking appliances shall be so constructed as to avoid possibility of cooking utensils being brought into contact with live parts and to prevent short circuits or damage to insulation due to liquid spilling or leakage.

15.3 OIL AND FUEL PRE-HEATING APPLIANCES

15.3.1 Oil and fuel having a flash point above 60°C may be pre-heated provided the requirements of 15.3.2 and 15.3.3 are complied with.

15.3.2 Electric pre-heaters for oil and fuel pipelines shall be equipped with the temperature regulators visual signal, indicating service condition and also with visual and audible signals indicating the fault conditions or inadmissible temperature rise.

15.3.3 Electrical heaters for oil and fuel tanks shall be provided with the temperature regulators through the transmitters of the surface temperatures of heating coils, low level indicators and means for cut-out of power supply to the heaters in case the uppermost temperature limit or the lowest permissible level of the medium is exceeded.

In addition, provision shall be made for the visual signal indicating service conditions as well as the visual and audible signal of the fault condition of the heating appliance.

15.3.4 In addition to the requirements of 15.3.3, provision shall be made for the automatic power supply cut-out to the heater as soon as its surface temperature reaches 220°C.

Restoring of the automatic power supply cut-out device to its initial position shall be effected only manually.

Table 15.1.5

No.	Part of the appliance	Material	Permissible temperature °C
1	Control handles and other parts to be handled for long period of time	Metallic	55
		Non-metallic	65
2	Same, but where shore-time Contact is concerned	Metallic	60
		Non-metallic	70
3	Enclosures of electrical heating appliances for spaces at ambient temperature of 20°C		80
4	Air coming out from a heating appliance into heated space		110
5	Air outlets		130

16 CABLES AND CONDUCTORS

16.1 GENERAL REQUIREMENTS

16.1.1 Cables are to be of a type approved. Cables manufactured in accordance with the relevant recommendation of IEC 60092-350:2020, 60092-352:2005, 60092-353:2016, 60092-354:2020, 60092-360:2014, 60092-370:2019 and 60092-376:2017 will be accepted by the *Register* provided that are tested to satisfaction.

16.1.2 Cables manufactured and tested to standards other than those specified in 16.1.1 will be accepted provided they are in accordance with an acceptable and relevant international or national standard and are of an equivalent or higher safety level than those listed in 16.1.1. However, cables such as flexible cable, fiber-optic cable, etc. used for special purposes may be accepted provided they are manufactured and tested in accordance with the relevant standards accepted by the *Register*.

16.1.3 The requirements of this Part of the Rules do not apply to the coaxial cables, telephone cables and to power cables designed for voltages above 1000 V.

16.2 CONDUCTORS

16.2.1 Cable conductors intended for supplying essential consumers shall be stranded (see also 16.8.1.2). Table 16.2.1 specifies the minimum required number of wires per conductor with respect to the nominal cross-sectional area.

Table 16.2.1

No.	Nominal cross-sectional area of conductor, (mm ²)	Minimum permissible number of wires per conductor	
		Circular non-tightened conductors	Tightened sector and circular conductors
1	05 - 6,0	7	—
2	10 - 16	7	6
3	25 - 35	19	6
4	50 - 70	19	15
5	95	37	15
6	120 - 185	37	30
7	240 - 300	61	30

Note:
The ratio between nominal diameters of two wires of mechanically tightened cable conductor shall not exceed 1:1,3, and for non-tightened geometrically formed wires 1:1,8.

16.2.2 The mutual cross-position of two adjacent wires of the conductor shall be displaced from one another by at least 500 mm lengthwise. Such crossings shall not impair the mechanical and electrical properties of the conductor.

16.2.3 Particular wires of rubber-insulated copper conductors shall be tinned or coated with suitable alloys.

This requirement may be dispensed with, provided the *Register* states, that the rubber insulation due to corresponding treatment does not affect adversely the metal of the conductor.

No tinning is required for conductors provided with other types of insulation.

16.3 INSULATING MATERIALS

16.3.1 The Table 16.3.1 specifies the insulating materials for cables and conductors.

Application of other insulating materials is subject to special consideration by the *Register* in each particular case.

Table 16.3.1

No.	Type of insulation	Standard types of insulating materials	Permissible conductor service temperature °C
1	PVC/A	Standard polyvinylchloride	60
2	PVC/D	Heat-resistant polyvinylchloride	75
3	EPR	Ethylene-propylene rubber	85
4	XLPE	Cross-linked polyethylene	85
5	S 95	Silicone rubber	95

16.4 COATINGS

16.4.1 Coatings of cables and conductors may be manufactured of the following materials:

- .1 non-metallic materials as specified in Table 16.4.1.
- .2 lead;
- .3 copper.

Application of other materials is subject to special consideration of the *Register* in each case.

Table 16.4.1

No.	Designation	Type of coating	Maximum permissible service temperature of conductor, (°C)
1	ST1	Standard polyvinylchloride	60
2	ST2	Heat-resistant polyvinylchloride	85
3	SE1	Polychloroprene	85
4	S4	Chlorosulfonated polyethylene	85

16.4.2 Cable coating shall be of uniform thickness, within permissible limits, throughout the length and shall envelope the cable cores concentrically. The coating shall be impervious covering tightly the protected cores.

16.4.3 Lead cable coverings shall be made of appropriate alloys in accordance with national standards.

Pure lead coatings may be used only when they are covered with an additional protective envelope.

16.5 PROTECTIVE SHEATHING

16.5.1 Electrical protective sheathing shall consist of braids made of copper wires. Where un-tinned copper wires are used, they shall be protected additionally by suitable sheaths.

The braid shall be uniform and its density shall be such that its mass is at least equal to 90 percent of the mass of the tube of equal diameter made of the same material and with a wall thickness equal to the braid wire diameter.

16.5.2 Mechanical protective sheathing shall consist of armour made of annealed steel wire or tape galvanised and wound helically, with a suitable pitch, over the cable sheath or an intermediate bedding over the sheath in such a way that a continuous cylindrical layer is formed to assure adequate protection and flexibility of the finished cable.

At special request, the armour may be made of non-magnetic metals.

16.5.3 Metal armour or braid made of steel wire or tape shall be protected against corrosion.

16.5.4 Armour bedding shall be made of moisture-resistant materials.

16.6 MARKING

16.6.1 Rubber or polyvinylchloride-insulated cables for limit temperature exceeding 60°C, shall be marked in such a manner as to clearly differ from all other cables.

16.6.2 Cable cores shall be marked with permanently legible identifications.

In multi-core cables with cores arranged in several concentric layers, at least two adjacent cores in each layer shall be marked with different colours.

16.7 CONDUCTOR LAYING

16.7.1 Single-wire insulated conductors may be used for internal wiring of distribution boards and electrical devices.

16.7.2 Non-insulated conductors and busbars are permitted only in internal parts of electrical devices. The external installation of non-insulated wires and busbars shall be allowed only if they are reliably protected.

16.8 CABLING

16.8.1 General requirements

16.8.1.1 Non-combustible and flame-retardant cables and conductors with copper cores manufactured in compliance with the requirements of the present part of the Rules or ap-

proved standards shall be used only. The use of other cables, as well as conductors shall be subject to special consideration by the *Register*.

All electric cables and wiring external to equipment shall be at least of a flame-retardant type (this may be achieved by cables which have been tested in accordance with IEC 60332-1-2:2004+AMD1:2015 or a test procedure equivalent thereto) and shall be so installed as not to impair their original flame-retarding properties (see 16.8.4.3.1 and 16.8.4.3.2).

Cables and wiring serving essential or emergency power, lighting, internal communications or signals shall so far as practicable be routed clear of galleys, laundries, machinery spaces of category A and their casings and other high fire risk areas (high fire risk areas are those considered as such in the *Rules for the classification of ships, Part 17 – Fire protection, Section 9*).

16.8.1.2 Cables and conductors having stranded copper cores may be used with cross-sectional areas being not less than:

- 1 1,0 mm² - for power, control and signalling circuits of essential services as well as for power circuits of other services;
- 2 0,75 mm² - for other power and signalling circuits;
- 3 0,5 mm² - for cables with number of cores not less than 4 for instrumentation and internal communication circuits.

For power circuits supplying non-essential services, the cables with single-wire cores having cross-sectional area up to 1,5 mm² may be used.

16.8.1.3 In circuits with heavy inductive and capacitate loads, the cables intended for working voltage equal to twice the rated voltage of the circuit shall be used.

16.8.1.4 Maximum permissible temperature for the insulating material of the cable cores and conductors shall be at least 10°C higher than the expected ambient temperature.

16.8.1.5 In locations affected by the action of petroleum products or other aggressive media, cables with sheathing resistant to such media shall be used. Cables without such protection may be installed in such locations only, if laid in metallic pipes (see 16.8.8).

16.8.1.6 In locations where cables may be exposed to mechanical damage, the cables with appropriate protective armour shall be used. Cables without protective armour shall be protected, in such locations by special covers or shall be laid in the metallic pipes (see 16.8.8).

16.8.2 Choice of cables and conductors with regard to loads

16.8.2.1 Permissible continuous current loads of cables with different number of cores and insulation materials, at ambient temperature 45°C, shall be in compliance with Tables 16.8.2.1-1 to 16.8.2.1-5.

Table 16.8.2.1-1

Polyvinylchloride insulated cables intended for core maximum permissible service temperature of 60°C					
Nominal cross-sectional area, mm ²	Single-core A	Double-core A	3-4 core A	Multi-core	
				mm ²	A
1	8	7	6	5 x 1,5	7
1,5	12	10	8	7 x 1,5	6
2,5	17	14	12	10 x 1,5	6
4	22	19	15	12 x 1,5	5
6	29	25	20	14 x 1,5	5
10	40	34	28	16 x 1,5	5
16	54	46	38	19 x 1,5	4
25	71	60	50	24 x 1,5	4
35	87	74	61		
50	105	89	74		
70	135	115	95		
95	165	140	116		
120	190	162	133		
150	220	187	154		
185	250	213	175		
240	290	247	203		
300	335	285	235		

Table 16.8.2.1-2

Polyvinylchlorid insulated cables intended for core maximum permissible service temperature of 75°C					
Nominal cross-sectional area, mm ²	Single-core A	Double-core A	3-4 core A	Multi-core	
				mm ²	A
1	13	11	9	5 x 1,5	10
1,5	17	14	12	7 x 1,5	9
2,5	24	20	17	10 x 1,5	8
4	32	27	22	12 x 1,5	7
6	41	35	29	14 x 1,5	7
10	57	48	40	16 x 1,5	7
16	76	65	53	19 x 1,5	6
25	100	85	70	24 x 1,5	6
35	125	106	88		
50	150	128	105		
70	190	162	133		
95	230	196	161		
120	270	230	189		
150	310	264	215		
185	350	298	245		
240	415	353	291		
300	475	404	333		

Table 16.8.2.1-3

Polyvinylchlorid insulated cables intended for core maximum 80°C					
Nominal cross-sectional area, mm ²	Single-core A	Double-core A	3-4 core A	Multi-core	
				mm ²	A
1	15	13	11	5 x 1,5	11
1,5	19	16	13	7 x 1,5	11
2,5	26	22	18	10 x 1,5	9
4	35	30	25	12 x 1,5	8
6	45	38	32	14 x 1,5	8
10	63	54	44	16 x 1,5	7
16	84	71	59	19 x 1,5	7
25	110	94	77	24 x 1,5	7
35	140	119	98		
50	165	140	116		
70	215	183	151		
95	260	221	182		
120	300	255	210		
150	340	289	238		
185	390	332	273		
240	460	391	322		
300	530	450	371		

Table 16.8.2.1-4

Polyvinylchlorid insulated cables intended for core maximum 85°C					
Nominal cross-sectional area, mm ²	Single-core A	Double-core A	3-4 core A	Multi-core	
				mm ²	A
1	16	14	11	5 x 1,5	11
1,5	20	17	14	7 x 1,5	10
2,5	28	24	20	10 x 1,5	9
4	38	32	27	12 x 1,5	8
6	48	41	34	14 x 1,5	7
10	67	57	47	16 x 1,5	6
16	90	77	63	19 x 1,5	6
25	120	102	84	24 x 1,5	6
35	145	123	102		
50	180	153	126		
70	225	191	158		
95	275	234	193		
120	320	272	224		
150	365	310	256		
185	415	353	291		
240	490	417	343		
300	560	476	392		

Table 16.8.2.1-5

Polyvinylchlorid insulated cables intended for core maximum 95°C					
Nominal cross-sectional area, mm ²	Single-core A	Double-core A	3-4 core A	Multi-core	
				mm ²	A
1	20	17	14	5 x 1,5	14
1,5	24	20	17	7 x 1,5	13
2,5	32	27	22	10 x 1,5	11
4	42	36	29	12 x 1,5	10
6	55	47	39	14 x 1,5	10
10	75	64	53	16 x 1,5	9
16	100	85	70	19 x 1,5	9
25	135	115	95	24 x 1,5	8
35	165	140	116		
50	200	175	140		
70	255	217	179		
95	310	264	217		
120	360	306	252		
150	410	349	287		
185	470	400	329		
240	570	485	400		
300	660	580	460		

16.8.2.1.1 Permissible current loads of cores are applicable when installing not more than 6 cables in one plane closely adhering to one another.

16.8.2.1.2 When more than 6 cables are installed in one bunch at simultaneity factor 1, the following correction factors shall be applicable for specifying continuous permissible current loads:

Table 16.8.2.1.2

Number of cables in bunch	Correction factors
7	0,98
8	0,95
9	0,91
10	0,87
11	0,84
12	0,81
13	0,79
14	0,78
15	0,77

16.8.2.2 If the ambient temperature is not 45°C, correction factors shall be applied to determine permissible continuous current ratings in accordance with the Table 16.8.2.2.

16.8.2.3 In case of intermittent current, load correction factors to determine continuous permissible current ratings in accordance with the Table 16.8.2.3 shall be applied.

16.8.2.4 In choosing the cables for final branch circuits of lighting and cooking appliances no correction factors or simultaneity factors shall be applied.

16.8.2.5 Cables provided with short-circuit current protection by means of time-delayed circuit breakers, shall be so designed as to withstand thermal strain due to time/current characteristic of the protective device as well as the peak values of prospective currents of the first one-half period.

16.8.2.6 Cables installed in parallel and laid together shall be of the same type, length and cross-sectional area of at least 10 mm².

Table 16.8.2.2

Permissible core service temperature		Ambient temperature, °C											
		35	40	45	50	55	60	65	70	75	80	85	
°C	Table	Correction factor											
60	16.8.2.1.a	1,29	1,15	1,0	0,82								
75	16.8.2.1.b	1,15	1,08	1,0	0,91	0,82	0,71	0,58					
80	16.8.2.1.c	1,13	1,07	1,0	0,93	0,85	0,76	0,65	0,53				
85	16.8.2.1.d	1,12	1,06	1,0	0,94	0,87	0,79	0,71	0,61	0,50			
95	16.8.2.1.e	1,10	1,05	1,0	0,95	0,89	0,84	0,77	0,71	0,63	0,55	0,45	

Table 16.8.2.3

Nominal core, cross-sectional area mm ²	Intermittent service intermittent ratio 40%		Short-time service S 1 – 30 min.		Short-time service S 2 – 60 min.	
	Cables and conductors					
	with metal metal armour	without metal armour	with metal metal armour	without metal armour	with metal metal armour	without metal armour
1	1,24	1,09	1,06	1,06	1,06	1,06
1,5	1,26	1,09	1,06	1,06	1,06	1,06
2,5	1,27	1,10	1,06	1,06	1,06	1,06
4	1,30	1,14	1,06	1,06	1,06	1,06
6	1,33	1,17	1,06	1,06	1,06	1,06
10	1,36	1,21	1,08	1,06	1,06	1,06
16	1,40	1,26	1,09	1,06	1,06	1,06
25	1,42	1,30	1,12	1,07	1,06	1,06
35	1,44	1,33	1,14	1,07	1,07	1,06
50	1,46	1,37	1,17	1,08	1,087	1,06
70	1,47	1,40	1,21	1,09	1,09	1,06
95	1,49	1,42	1,25	1,12	1,11	1,07
120	1,50	1,44	1,28	1,14	1,12	1,07
150	1,51	1,45	1,32	1,17	1,14	1,08
185	–	–	1,36	1,20	1,16	1,09
240	–	–	1,41	1,24	1,18	1,10
300	–	–	1,46	1,28	1,20	1,12

16.8.3 Selection of cable cross-sectional area with respect to permissible voltage drop

16.8.3.1 Voltage drop on the cables connecting the generators with the main switchboard or emergency switchboard shall not exceed 1 percent of the rated voltage.

16.8.3.2 Voltage drop between busbars of the main or emergency switchboard and any points of the network shall not exceed 6 percent under normal operating conditions and for consumers supplied from the accumulator battery with the rated voltage up to 50 V, 10 percent of the rated voltage.

For circuits of navigational lights in case that luminous intensity is in question, a lesser permissible value may be required.

16.8.3.3 Cables used for feeding directly started electrical motors shall be so selected that the voltage drop on motor terminals at starting, shall not exceed 25 percent of the rated voltage.

16.8.4 Laying of cables

16.8.4.1 Cables shall be laid in runs which shall be straight and accessible in such a manner that they are not exposed to mechanical damage or oil, fuel, water and excessive external heating.

Cable runs shall be installed at a distance not closer than 100 mm to source of heat.

16.8.4.2 No cables shall be installed at a distance less than 50 mm from the double bottom and from the fuel and oil tanks.

Cable runs shall be laid at a distance not less than 20 mm from the shell plating and decks as well as from fireproof, watertight and gaslight bulkheads.

16.8.4.3 Where cables are laid in bunches, special provisions shall be taken to prevent fire spread over cable runs.

16.8.4.3.1 Cables laid in bunches shall be type approved in accordance with the IEC 60332-3-22:2018 Category A or equivalent thereto.

16.8.4.3.2 Where bunches consist of cables which are not approved in accordance with the preceding item, to prevent fire spread the following measures shall be taken (see figure 16.8.4.3.2):

- a) Fire stops having at least BO penetrations fitted as follows:
 1. cable entries at the main and emergency switchboard,
 2. where cables enter engine control rooms,
 3. cable entries at centralised control panels for propulsion machinery and essential auxiliaries,
 4. at each and of totally enclosed cable trunks.
- b) In enclosed and semi-enclosed spaces, cable runs are to comply with the following:
 1. to have fire protection coating applied:
 - 1.1 to at least 1 metre in every 14 metres for horizontal runs,
 - 1.2 to entire length of vertical runs, or
 2. fitted with fire stops having at least BO penetrations every second deck or approximately 6 metres for vertical runs and at every 14 metres for horizontal runs.

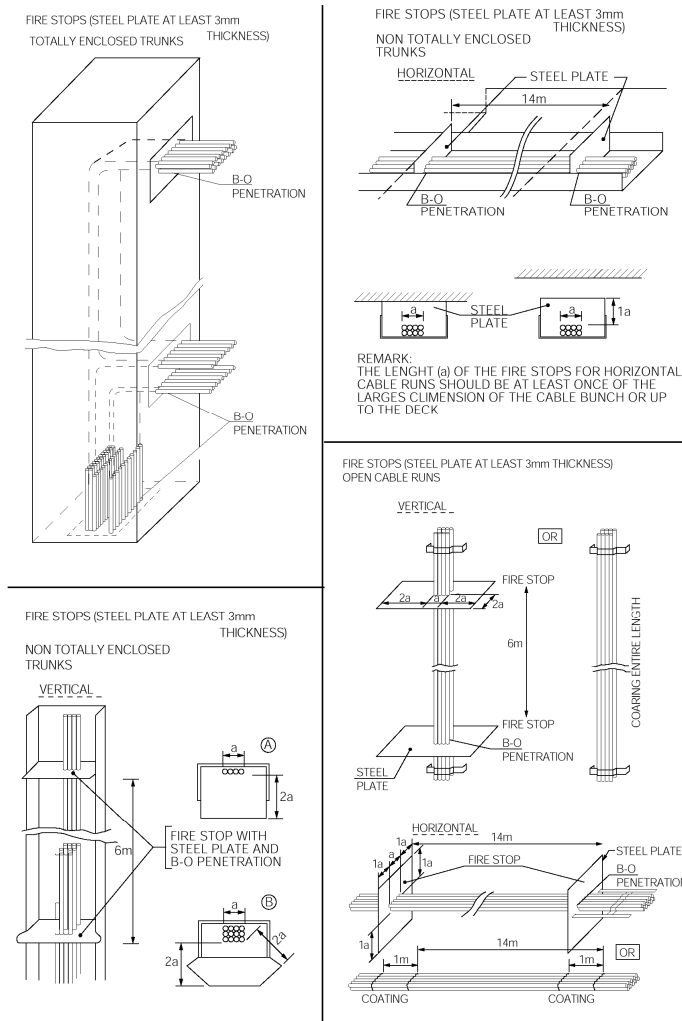

Fig. 16.8.4.3.2

16.8.4.4 Cables provided with metallic sheath may be installed on light metal structures or be fastened by means of light metal cable clips only if reliable anticorrosive protection is foreseen.

16.8.4.5 No cable runs shall be laid through the cargo spaces intended for carriage of dangerous goods.

However, if this cannot be avoided, each particular case shall be subject to special consideration by *Register*.

16.8.4.6 Cables laid in fishing vessels at locations exposed to action of salt shall be adequately protected with covers or shall be provided with salt-resistant sheaths.

16.8.4.7 No cables shall be installed under the machinery space flooring.

If this cannot be avoided, cables shall be laid in metallic pipes or in closed conduits. (see 16.8.8).

16.8.4.8 Cables installed over the expansion points in the hull structure shall be provided with expansion loops with an adequate radius for such joint.

The inside diameter of a loop shall not be less than 12 outside cable diameters.

16.8.4.9 Cables having insulation intended for different permissible temperatures in the common cable runs, shall be laid so that no one is heated above its permissible temperature.

16.8.4.10 Cables with different protective sheatings, the less resistant of which may be damaged, shall not be laid in common ducts, pipes or conduits without being adequately fastened.

16.8.4.11 Cables of the electrical propulsion plant motors shall be laid separately from the cables of lower voltage or for another purpose.

16.8.4.12 Cores of the same multi-core cable shall not be used for power supply and control of essential services not associated with one another.

Multi-core cables shall also not be used simultaneously for safety voltage and service voltage exceeding safety level.

16.8.4.13 If equipment is fed by two separate cables, these cables shall be laid in separate runs as far apart as possible in horizontal and vertical direction.

16.8.4.14 When cables are laid in ducts or other structures of combustible materials the ways of cable laying shall be protected against ignition by means of linings, coatings or impregnation's.

16.8.4.15 Cables shall not be installed into acoustic or thermal insulation if they are made of combustible materials.

Cables shall be separated from such insulation by the lining of non-combustible material or shall be installed at a distance of at least 20 mm from it.

When cables are laid in acoustic or thermal insulation made of non-combustible material, their maximum continuous current rating shall be reduced to 70 percent of nominal rating.

16.8.4.16 Cables in refrigerated spaces shall be provided with protective sheath of metal, polychloroprene rubber or other material resistant to the cooling agent. When cables are

provided with metal sheathing, it shall be adequately protected against corrosion.

16.8.4.17 Cables in refrigerated spaces shall be laid on perforated panels or bridges and fastened in such a manner that a free space is available between cable and walls of the room.

Panels, bridges, clips and screws shall be adequately protected against corrosion.

Where cables are led through the thermal insulation of the refrigerated space, the runs shall be effected perpendicular to it through appropriate gland pockets sealed on both ends.

16.8.4.18 When laying the cables, the cable bending radius shall be in accordance with Table 16.8.4.18.

16.8.4.19 Cables and earthing conductors of the equipment mounted on shock absorbers shall be so installed that they cannot be damaged in service.

Table 16.8.4.18

Type of cable		External diameter of cable (d), mm	Minimum permissible bending radius of cable
Kind of insulation	Kind of protective sheathing		
Rubber or polyvinylchloride	Armoured with metal tapes or wires	Any	10 d
	Protected with metal sheath	Any	6 d
	Lead armour	Any	6 d
	Other sheaths	Up to 9,5	3 d
		9,5 to 25,4	4 d
Over 25,4	6 d		
Varnished cambric	Any	Any	8 d
Mineral insulation	Metallic	Up to 7	2 d
		7 to 12,7	3 d
		Over 12,7	4 d
Ethylene-propylene rubber or cross-lined polyethylene	Semiconducting or metallic	25 and over	10 d

16.8.5 Fastening of cables

16.8.5.1 Cables shall be adequately fastened by means of clips, holders, hangers etc. manufactured of metal or other non-combustible or flame-retardant material.

The fastener surface shall be sufficiently wide and shall have no sharp edges.

The fasteners shall be so tightened that the cables are securely fastened without damage to their outer protective coverings.

16.8.5.2 Distances between cable fastening points when laid horizontally shall not exceed the values referred to in Table 16.8.5.2.

For vertical cable runs these distances may be increased by 25 percent.

Table 16.8.5.2

Ethernal diameter of cable (d) (mm)		Distance between fastening points, mm		
		Without shear	With shear	With mineral insulation
–	8	200	250	300
8	13	250	300	370
13	20	300	350	450
20	30	350	400	450
30		400	450	450

16.8.5.3 Cables shall be so fastened that mechanical strains in cables are not transmitted to their inlets or connections.

16.8.5.4 Cable trays and cables installed parallel to shell plating, shall be fastened to ship's structure and not to shell plating.

On watertight bulkheads and masts, cables shall be fastened on special supports such as tray plates, bridges, etc.

16.8.5.5 Cables running parallel to bulkheads subject to sweating shall be installed on bridges or perforated trays in such a manner that free space is available between cables and bulkheads.

16.8.5.6 Cable trays shall be installed with a minimum number of crossings.

Where cables cross each other, bridges shall be used, so that a distance of not less than 5mm is left between the bridge and the cable tray crossing it over.

16.8.5.7 For ships constructed from non-conducting materials, it is permitted, due to the technology of hull construction from these materials, the properties of the materials used, to accept the equivalent to the requirements for the installation, fastening and sealing of penetrations of cables and cable trays specified in the rules for steel ships.

16.8.6 Cables penetrating decks and bulkheads

16.8.6.1 Penetrations through watertight, gastight and fire bulkheads as well as decks shall be sealed. Sealing where cables penetrate these bulkheads and decks shall not reduce their tightness.

In this case no force shall be transmitted to cables resulting from elastic deformations of ship's hull.

16.8.6.2 When installing the cables through non-tight bulkheads or elements of ship's structure less than 6mm thick, the penetrations of cables shall be fitted with linings or rings to protect cables from damages.

Where bulkheads or ship's structure are more than 6mm thick, no linings or rings shall be required, but the edges of holes shall be rounded.

16.8.6.3 Cables penetrating the decks shall be protected against mechanical damages to a height of 700 mm above the deck and where such damages are not likely to occur, to a height of 200 mm.

Cable penetrations shall be sealed with adequate cable compound.

When installing individual cable sealing gland may be used instead of cable compound.

16.8.7 Packing compounds

16.8.7.1 To fill up cable boxes in watertight bulkheads and decks, the packing compounds shall be used which have good adhesion to the inside surfaces of cable boxes and cable sheaths are resistant to action of water and oil products and which shall not shrink and be liable to cracking, also which shall ensure their tightness under conditions specified in 2.1.1.

16.8.7.2 Packings of cable penetrations through fire-resisting bulkheads shall comply with the requirements for standard fire tests specified for the given type of bulkhead in the *Rules for the classification of ships, Part 17 - Fire protection*.

16.8.8 Installation of cables in pipes and conduits

16.8.8.1 Metallic pipes and conduits wherein cables are laid shall be protected from corrosion on the inside and the outside surfaces. The inside surface shall be even and smooth. Their ends shall be machined so that no damage is caused to the cables when they are drawn through. Cables with lead armour, without additional protective covering, shall not be drawn through pipes or conduits.

16.8.8.2 The pipe and conduit bending radii shall not be smaller than the permissible bending radii for cables of the largest diameter installed in them, in accordance with 16.8.4.18.

16.8.8.3 The total cross-sectional area of all cables laid in pipe or conduit, measured on their outside diameters, shall not exceed 40 percent of the inside cross-sectional area of the pipe or conduit.

16.8.8.4 The pipes and conduits shall be mechanically and electrically continuous and reliably earthed if the earthing has not been already ensured by the pipe or conduit mode of installation.

16.8.8.5 The pipes and conduits shall be installed in such a manner that no water can accumulate therein. If this is not possible, ventilation holes shall be provided in the pipes and conduits, as far as possible, in the highest and lowest points, so that air circulation is ensured and vapour condensation is prevented.

The holes shall be permitted only where they do not enhance the danger of explosion or fire.

16.8.8.6 Cable pipes and conduits installed alongside ship's hull which can be damaged due to the hull deformation shall be provided with compensation facility.

16.8.8.7 If in accordance with 16.8.1.1 the cables with combustible coverings may be used, these cables shall be installed in metallic pipes over their total length.

16.8.8.8 Cables installed in vertical pipes and conduits shall be so fastened that they are not damaged due to their own weight.

16.8.9 Special requirements for a.c. single-core cables

16.8.9.1 A.C. single-core cables are not recommended. When however their use cannot be avoided, they shall comply with the following requirements:

- .1 the cables shall not be armoured with magnetic material;
- .2 cables belonging to the same circuit shall be laid within the same tray or pipe.
The cables may be laid in different pipes only in case pipes of non-magnetic materials are used;
- .3 cable clamps shall include all the single-core cables of a circuit, unless they are made of non-magnetic material;
- .4 cables shall be laid closely to each other and if they shall be spaced in order to avoid heating, the distance between them shall not be greater than one cable diameter.

16.8.9.2 Where single-core cables pass through bulkheads and decks, there shall be no magnetic material between cables belonging to the same circuit.

The clearance between the cables and the magnetic material shall not be less than 75 mm.

16.8.9.3 When single-core cables having a current rating over 250 A are laid along the steel structures, the clearance between such cables and the structure shall be at least 50 mm.

16.8.9.4 When laying single-core cables of 30 m in length and over with cross-section over 185 mm², crossings of cables shall be inter changed at distances not exceeding 15 m.

16.8.9.5 Multicore cables with cores connected in parallel shall be laid as single-core cables and all the requirements for single-core cables apply to this case.

16.8.10 Connection and prolongation of cables

16.8.10.1 Ends of rubber insulated cables, mineral insulated cables and those with metal armour when prolonged, shall be so packed as to prevent moisture penetration inside the cables.

16.8.10.2 Protective covering of cables inserted into a device, apparatus or distribution box shall enter not less than 10 mm inside.

16.8.10.3 Cables may be connected at places of tapping only within the distribution boxes by means of terminals.

16.8.10.4 If during the installation of cables it appears necessary to make additional connections, these shall be effected in suitable distribution boxes fitted with terminals and protected against harmful influence from outside.

The application of other equivalent cable jointing and connection is subject to special consideration by the *Register* in each particular case (see 18.9.6).

16.8.11 Electrical Services Required to be Operable Under Fire Conditions and Fire Resistant Cables

16.8.11.1 Electrical services required to be operable under fire conditions are as follows:

- Fire and general alarms
- Fire-extinguishing systems and fire-extinguishing media release alarms
- Fire detection systems
- Control and power systems to power-operated fire doors and status indication for all fire doors
- Control and power systems to power-operated watertight doors and their status indication
- Emergency lighting
- Public address systems
- Low location lighting
- Emergency fire pump
- Remote emergency stop/shutdown arrangements for systems which may support the propagation of fire and/or explosion

16.8.11.2 Where cables for services specified in 16.8.11.1 including their power supplies pass through high fire risk areas, and in addition for passenger ships, main vertical fire zones, other than those which they serve, they are to be so arranged that a fire in any of these areas or zones does not affect the operation of the service in any other area or zone. This may be achieved by either of the following measures:

- a) Cables being of a fire resistant type complying with IEC 60331-1:2018 for cables of greater than 20 mm overall diameter, otherwise IEC 60331-21:1999+AMD1:2009 or IEC 60331-2:2018 for cables with an overall diameter not exceeding 20 mm, are installed and run continuous to keep the fire integrity within the high fire risk area, see Figure 16.8.11.
- b) At least two-loops/radial distributions run as widely apart as is practicable and so arranged that in the event of damage by fire at least one of the loops/radial distributions remains operational.

Systems that are self-monitoring, fail safe or duplicated with cable runs as widely separated as is practicable may be exempted.

16.8.11.3 The electrical cables to the emergency fire pump are not to pass through the machinery spaces containing the main fire pumps and their source(s) of power and prime mover(s). They are to be of a fire resistant type, in accordance with 2 (a), where they pass through other high fire risk areas.

16.8.11.4 For the purpose of this item application, the definition for “high fire risk areas” is the following:

- a) Machinery spaces as defined by Regulation 3.30 of SOLAS Chapter II-2, as amended by IMO resolutions up to MSC.421(98) (hereinafter the same), except spaces having little or no fire risk as defined by paragraphs (10) of Regulation 9.2.2.3.2.2 of SOLAS Chapter II-2. (Including the interpretations for tables 9.3, 9.4, 9.5, 9.6, 9.7 and 9.8 given in

- MSC/Circ.1120) as amended by MSC.1/Circ.1436 and MSC.1/Circ.1510)
- b) Spaces containing fuel treatment equipment and other highly flammable substances
 - c) Galley and Pantries containing cooking appliances
 - d) Laundry containing drying equipment
 - e) Spaces as defined by paragraphs (8), (12), and (14) of the *Rules for the classification of ships, Part 17 – Fire protection*, item

9.2.2.3.2.2 for ships carrying more than 36 passengers.

16.8.11.5 Fire resistant type cables should be easily distinguishable.

16.8.11.6 For special cables, requirements in the following standards may be used:

- IEC60331-23:1999
- IEC60331-25:1999

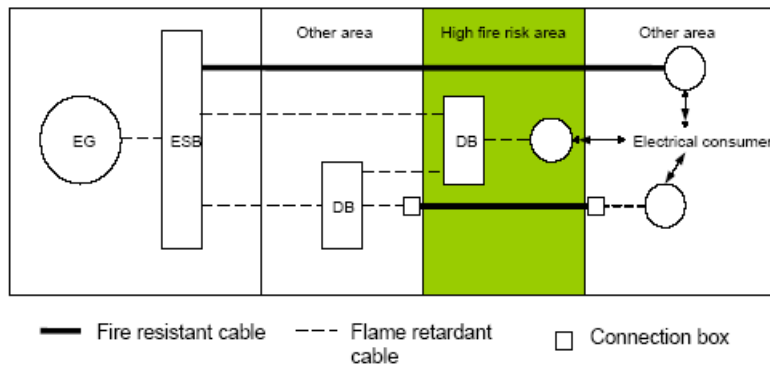

Fig. 16.8.11

16.9 CABLE TRAYS AND PROTECTIVE CASINGS MADE OF PLASTICS MATERIALS

16.9.1 General requirement

16.9.1.1 Cable trays and protective casings made of plastic materials are to be type tested in accordance to the requirements of IACS Recommendation No. 73 - Type approval procedure for cable trays/protective casings made of plastics materials.

16.9.1.2 **Plastic** –means both thermoplastic and thermosetting plastic materials with or without reinforcement, such as PVC and fibre reinforced plastic – FRP.

Protective casing- means a closed cover in the form of a pipe or other closed ducts of non-circular shape.

16.9.2 Installation requirements

16.9.2.1 Cable trays and protective casings made of plastic materials are to be supplemented by metallic fixing and straps such that in the event of the fire tray, and the cables affixed, are prevented from falling and causing an injury to personnel and obstruction to any escape route.

16.9.2.2 When plastics cable trays and protective casings are used on open deck, they are additionally to be protected against UV light.

16.9.2.3 The load on the cable trays and protective casings is to be within to Safe Working Load (SWL).

16.9.2.4 The selection and spacing of cable trays and protective casings supports are to take into account:

- cable trays and protective casings’ dimensions,
- mechanical and physical properties of materials,
- mass of cable trays and protective casings,
- loads due weight of cable, external forces, thrust forces and vibrations,
- maximum accelerations to which the system may be subjected,
- combination of loads.

16.9.2.5 The sum of the cables’ total cross sectional area, based on the cables’ external diameter, is not to exceed 40% of the protective casing’s internal cross section area. This does not apply to a single cable in a protective casing.

17 ELECTRICAL PROPULSION PLANT

17.1 GENERAL REQUIREMENTS

17.1.1 The electrical equipment of the electrical propulsion plant shall comply also with the requirements of other Sections and items of the present part of the Rules, except otherwise specified in this Section.

17.1.2 Propulsion generators may be used for supplying auxiliary electrical machines and devices, provided, voltage and frequency stability can be assured under all running conditions including those of manoeuvring in compliance with 2.1.1.1.

17.1.3 Electrical heating is recommended to be fitted in the spaces with electrical machines, switchboards and control panels.

17.1.4 Fixed installed lighting shall be provided underneath the generators and motors of the electrical propulsion plant.

17.1.5 Part of electrical propulsion machines (generators and motors) located under flooring shall have the degree of mechanical protection not below IPX4.

In case they are installed in a dry compartment or protected against ingress of water by a watertight foundation and also a signal is provided which is activated upon water entering the compartment, IPX3 protection may be permitted.

17.2 PERMISSIBLE SUPPLY VOLTAGES

In the electrical propulsion system, the voltage levels not exceeding the values referred to in 4.2 and 18.2.2 are permitted.

17.3 ELECTRICAL MACHINES

17.3.1 Cooling and ventilation

17.3.1.1 Generators and electrical motors with closed-circuit ventilation shall be provided with thermometers for measuring the temperature outlet of cooling air and water.

17.3.1.2 Generators and electrical motors of the electrical propulsion system shall be provided with visible and audible alarms operating in case of inadmissible winding temperature rise.

17.3.1.3 The closed-cooling ventilation system shall be provided with an air humidity indicator and with visible and audible alarms operating in case of inadmissible rise of the cooling air temperature.

17.3.1.4 The air-cooled electrical propulsion motors shall be equipped with two forced ventilation fans, each having sufficient capacity to ensure cooling air quantity for normal mo-

tor operation. Audible alarms are required to keep fan operation under control.

17.3.1.5 Generators and electrical motors of the electrical propulsion plant shall be fitted with filters for cleaning the cooling air both for open and closed circuit ventilation system.

Ventilation ducts shall be so constructed as to prevent penetration of water inside the machine.

17.3.1.6 Electrical machines cooled with liquid shall be provided with device for control of cooling system.

17.3.2 Bearings and lubrication

17.3.2.1 Pressure lubrication system of electrical propulsion machinery shall have two lubricating oil pumps, each with a capacity sufficient to ensure normal operating conditions of the plant.

17.3.2.2 The oil lubrication system for bearings shall incorporate a filter with a gravity feed tank to ensure oil supply to the bearings for not less than 15 min with the pump out of action unless the bearing design ensures normal lubrication during the ship's inertia movement.

17.3.2.3 Lubrication system shall be equipped with a signal which operates in the event of lubricating oil pressure drop as well as with means for measuring oil outlet temperature.

17.3.3 Machine excitation

17.3.3.1 The excitation system of the propulsion plant machines shall be fed from at least two converters of electric energy.

If one of these fails, the remaining one shall be capable of ensuring the total excitation power even at the increased load which occurs during manoeuvring.

The excitation system may be fed directly from the busbars of the main switchboard, provided the power supply is ensured under all propulsion conditions in accordance with the above requirements.

17.3.3.2 An excitation system for direct-current propulsion motors and generators shall be so designed that in case of excitation loss at the electrical propulsion motors, the generator excitation is immediately de-energized.

This requirement does not apply to systems with constant current or voltage having two or more electrical motors as well as to a special automatic excitation system which makes the above requirement unnecessary.

17.3.3.3 Excitation current circuits shall be provided with a device for discharging the magnetic field energy in the event of disconnecting the excitation winding. (see 5.4.3).

17.3.3.4 Excitation including automatic-control system shall be so designed that electrical propulsion motors are safeguarded from overspending in the event of the propeller breaking down or working clear of water.

For constant-current systems this requirement applies to all the electrical motors of the constant-current circuit.

17.3.3.5 Where the exciters of the electrical propulsion machines are intended to be used for feeding other machinery

or devices too, an interlocking shall be provided to prevent their use while the propulsion plant is in operation.

Instead of it a notice may be fitted in a suitable place to indicate that this source of supply may be used only while the propulsion plant is at a standstill.

This requirement does not apply to standby exciters.

17.3.3.6 The constant-current systems shall be provided with protective devices to ensure disconnection of the generator and electrical motor excitation in case of failure in the main current circuit.

17.4 SWITCHES IN MAIN AND EXCITATION CIRCUITS

17.4.1 No automatic circuit breakers shall be installed in the excitation circuits, other than those designed to control machine excitation in the event of short circuit or a failure in the main current circuit.

17.4.2 Where a definite sequence of switching operations shall be ensured, provision shall be made for a reliable interlock to prevent wrong switching.

17.4.3 Change-over switches intended to operate in de-energised conditions of electrical propulsion plant circuits, shall be suitably interlocked to prevent their opening or closing in the energised condition.

17.4.4 Generators and electrical motors of constant current systems shall be switched on or off by de-excitation without breaking the main current circuit.

17.5 CONTROL OF ELECTRICAL PROPULSION PLANT

17.5.1 The main control console shall be provided for each electrical propulsion plant located in the machinery space or in a special room.

Additional remote control consoles may be installed in the locations from where the ship's control is performed.

17.5.2 Where the electrical propulsion plant is controlled from the console or panel, by means of electrical, pneumatically or hydraulically actuating gear, the failure of such gear shall not render the electrical propulsion plant inoperative and each of the control consoles or the panels shall be ready for manual operation immediately.

17.5.3 When several control consoles of the electrical propulsion plant are provided, a control console room shall be fitted with a change-over switch for selection of corresponding control location. This change-over switch shall ensure that in each switch-position only one console can be activated.

17.5.4 The change-over switch shall be provided with an interlocking device not permitting change-over from one console to another until propulsion plant has been de-excited. This shall be effected by putting the handle of the control console being in operation to "stop" position.

In this case, irrespective of the position of the control handle at a newly selected console, the starting of the

propulsion motor shall be possible only through "stop" position.

17.5.5 Control consoles of electrical propulsion plant shall comply with the requirements of the *Rules for the classification of ships, Part 7 - Machinery Installation*.

17.5.6 The use of mechanically linked control consoles in the bridge is permitted in order to enable synchronous operation using them in turn.

17.5.7 The remote control system of the electric propulsion plant shall be so designed that no time delay is likely to occur when changing the control from one handle to the other on the control consoles located in the bridge.

17.5.8 The control system of the electrical propulsion plant shall incorporate an interlocking device to prevent the operation of plant with the shaft-turning gear engaged.

17.5.9 Others detail of control are mentioned in the *Rules for the classification of ships, Part 13 - Automation, 2.5*.

17.6 ELECTRICAL PROPULSION PLANT WITH SEMICONDUCTOR RECTIFIERS

17.6.1 General requirements

17.6.1.1 The power of sources of electrical power and consumers connected to the busbars of the electric propulsion plant shall be determined taking into account the prospective distortions of the voltage on these busbars as well as additional distortions resulting from asymmetry of the first and higher harmonics during transient conditions of the operation of electrical propulsion motors.

17.6.1.2 Generators, semi-conductor rectifiers, electrical propulsion motors as well as apparatus in the main current circuits shall be capable to withstand over-current of at least 250 percent of rated current during 2 sec.

17.6.1.3 The power of electrical propulsion motors shall be determined taking into account the prospective distortion of voltage on the terminals of semi-conductor rectifiers.

17.6.1.4 Generators and electrical propulsion motors shall ensure the required technical characteristics in accordance with the ship's purpose taking into account distortions of voltage and current due to semi-conductor rectifier operation.

17.6.1.5 Overloading of generators and electrical propulsion motors shall meet the requirements for their use on boardship. If necessary, provisions shall be made for compensation of the reduced overloading possibility due to higher voltage harmonics during operation of semi-conductor rectifiers.

17.6.1.6 Power condensers or filters used in semi-conductor rectifiers for upgrading the quality of electrical energy, shall be provided with discharge devices.

17.6.1.7 Consumers requiring high quality sine-form of supply voltage shall be fed from separate sources or shall be provided with locally installed devices for damping the higher

harmonics up to technically justified level, irrespective of the permissible voltage distortion coefficient.

17.6.2 Electrical propulsion plant with alternating - direct current

17.6.2.1 The coefficient of the current pulsation of electrical propulsion motors operating on rectified current shall be determined by the following formula:

$$K_p = \frac{\sqrt{\sum I_v^2}}{I_{dn}}$$

where:

v = number of harmonic component;

I_v = effective current value for v -harmonic component,

I_{dn} = rated value of rectified current;

This coefficient shall not exceed 2 percent.

17.6.2.2 The dynamic breaking current shall not exceed 200 percent of rated current.

17.6.3 Electrical propulsion plant with alternating - alternating current

17.6.3.1 The generator power shall be determined taking into account the prospective asymmetry of phase loading due to operation of the semiconductor frequency rectifiers.

17.7 PROTECTION OF ELECTRICAL PROPULSION PLANTS

17.7.1 Electrical propulsion plant systems shall have earth-fault protection.

The protective devices shall be so designed that the earth current does not exceed 20 mA.

17.7.2 Melt fuses shall not be used as means of protection in the main and excitation circuits (see 8.2.9 and 8.8.2).

17.7.3 Where direct-current generators of the electrical propulsion machinery are connected in series, protective devices shall be provided to prevent the reversal of the generating set in case of partial or complete loss of the prime mover torque.

Provisions shall also be made to ensure that in this case, only that generator of which prime mover is out of the operation, is switched off.

17.7.4 Arrangements shall be made to limit or utilize the power generated by the electrical propulsion motors under transient conditions or during propeller reversals, if such power is likely to cause over-speeding of generator prime movers.

Speed increase of the generator prime movers forming part of the electrical propulsion plant shall not exceed the values referred to in the *Rules for the classification of ships, Part 9 – Machines*, 2.11.

17.7.5 Electrical propulsion plant shall be protected from self-starting following the operation of any protective device.

17.7.6 The electrical propulsion plant shall have short-circuit and overload protection.

Operation of overload protection shall be preceded by visible and audible alarms.

Overload protection shall not be operable during manoeuvring.

17.7.7 Thyristor converters in the main and excitation circuits of generators and motors of electrical propulsion plant, shall have the following protection:

- .1 against internal and external short circuits and overloads;
- .2 against overvoltage;
- .3 against change of inverter state where the converter is to operate in the inverter mode;
- .4 loss of supply voltage in control system.

17.8 ACCESSORIES FOR MEASURING AND SIGNALLING

17.8.1 Minimum measuring instruments shall be provided to ensure permanent and direct control of the system characteristics which affect the operation of the electrical propulsion plant:

- .1 an ammeter in the main current circuit;
- .2 a voltmeter in the main current circuit;
- .3 an ammeter in the field circuit for adjustable excitation system;
- .4 a voltmeter in the field circuit for adjustable excitation systems;
- .5 a tachometer for propulsion motors or propeller shafts;

Additional requirements for electrical propulsion plant operating with the alternating current systems are:

- .6 a frequency indicator;
- .7 a synchronising device
- .8 a power-meter

17.8.2 The electrical propulsion plant system shall be equipped with an insulation resistance measuring device. The main current circuit shall be provided with the continuous insulation resistance measuring with visible and audible signals operating in the event of inadmissible decrease of insulation resistance.

This requirement is not applicable to electrical distribution systems with the neutral point earthed to the hull and being protected from connection to hull.

17.8.3 Each control console shall be provided with visual alarms to indicate the presence of voltage in the control circuits.

17.9 ELECTRICAL COUPLINGS

17.9.1 General requirements

17.9.1.1 Electrical couplings shall be so designed as to enable their dismantling without disassembling the driving motor or reduction gear.

17.9.1.2 Electrical couplings shall be so designed and arranged as to be freely accessible for maintenance, brush replacement and air gap measurements without dismantling the couplings.

17.9.1.3 Enclosures and end shields shall be made of steel or materials of equivalent strength (see 10.1.1).

17.9.1.4 The rotating parts of couplings and their windings shall be so designed and secured that they cannot be damaged in the event of sudden stop.

17.9.1.5 Electrical couplings shall not cause shaft axial stresses. They shall be balanced to comply with the requirements of the *Rules for the classification of ships, Part 9 – Machines*, 4.1.2.

17.9.1.6 The maximum torque under field forcing conditions shall not exceed twice the rated torque of the coupling.

17.9.1.7 The requirements of the present Section shall also apply to electrical couplings which are not part of electrical propulsion plant.

17.9.2 Protection and interlocking

Electrical couplings shall be so connected or interlocked that their excitation is not possible during the main propulsion motor starting or reversing.

17.9.3 Electrical coupling excitation

17.9.3.1 The field windings of electrical couplings shall be protected against overvoltage.

17.9.3.2 The field circuits of an electrical coupling shall incorporate at least:

- .1 a two-pole switch;
- .2 a magnetic field discharging device;
- .3 short-circuit protection.

18 ADDITIONAL REQUIREMENTS FOR ELECTRICAL EQUIPMENT DESIGNED FOR VOLTAGES ABOVE 1 kV TO 15 kV

18.1 GENERAL

18.1.1 Field of application

The following requirements apply to a.c. three-phase systems with nominal voltage exceeding 1 kV, the nominal voltage is the voltage between phases.

If not otherwise stated herein, construction and installation applicable to low voltage equipment generally apply to high voltage equipment.

18.1.2 Nominal system voltage

The nominal system voltage is not to exceed 15 kV.

Where necessary for special application, higher voltages may be accepted.

18.1.3 High-voltage, low-voltage segregation

Equipment with voltage above about 1 kV is not to be installed in the same enclosure as low voltage equipment, unless segregation or other suitable measures are taken to ensure that access to low voltage equipment is obtained without danger.

18.2 SYSTEM DESIGN

18.2.1 Distribution

18.2.1.1 Network configuration for continuity of ship services.

It is to be possible to split the main switchboard into at least two independent sections, by means of at least one circuit breaker or other suitable disconnecting devices, each supplied by at least one generator. If two separate switchboards are provided and interconnected with cables, a circuit breaker is to be provided at each end of the cable.

Services which are duplicated are to be divided between the sections.

18.2.1.2 Earthed neutral systems

In case of earth fault, the current is not to be greater than full load current of the largest generator on the switchboard or relevant switchboard section and not less than three times the minimum current required to operate any device against earth fault.

It is to be assured that at least one source neutral to ground connection is available whenever the system is in the energised mode. Electrical equipment in directly earthed

neutral or other neutral earthed systems is to withstand the current due to a single phase fault against earth for the time necessary to trip the protection device.

18.2.1.3 Neutral disconnection

Means of disconnection are to be fitted in the neutral earthing connection of each generator so that the generator may be disconnected for maintenance and for insulation resistance measurement.

18.2.1.4 Hull connection of earthing impedance

All earthing impedance's are to be connected to the hull. The connection to the hull is to be so arranged that any circulating currents in the earth connections do not interfere with radio, radar, communication and control equipment circuits.

18.2.1.5 Divided systems

In the systems with neutral earthed, connection of the neutral to the hull is to be provided for each section.

18.2.2 Degrees of protection

18.2.2.1 General

Each part of the electrical installation is to be provided with a degree of protection appropriate to the location, as a minimum the requirements of IEC 60092-201:2019.

18.2.2.2 Rotating machines

The degree of protection of enclosures of rotating electrical machines is to be at least IP 23.

The degree of protection of terminals is to be at least IP44.

For motors installed in spaces accessible to unqualified personnel, a degree of protection against approaching or contact with live or moving parts of at least IP4X is required.

18.2.2.3 Transformers

The degree of protection of enclosures of transformers is to be at least IP23.

For transformers installed in spaces accessible to unqualified personnel a degree of protection of at least IP4X is required.

For transformers not contained in enclosures, see item 18.7.1.

18.2.2.4 Switchgear, controlgear assemblies and converters

The degree of protection of metal enclosed switchgear, controlgear assemblies and static converters is to be at least IP32. For switchgear, control gear assemblies and static converters installed in spaces accessible to unqualified personnel, a degree of protection of at least IP4X is required.

18.2.3 Insulation

18.2.3.1 Air clearance

In general, for Non Type Tested equipment phase-to-phase air clearances and phase-to-earth air clearances between non-insulated parts are to be not less than those specified in Table 2.3.1.

Table 2.3.1

Nominal Voltage kV	Minimum air clearance (mm)
3 (3.3)	55
6 (6.6)	90
10 (11)	120
15	160

Intermediate values may be accepted for nominal voltages provided that the next higher air clearance is observed.

In the case of smaller distances, appropriate voltage impulse test must be applied.

18.2.3.2 Creepage distances

Creepage distances between live parts and between live parts and earthed metal parts are to be in accordance with IEC 60092-503:2007 for the nominal voltage of the system, the nature of the insulation material and the transient overvoltage developed by switch and fault conditions.

18.2.4 Protection

18.2.4.1 Faults on the generator side of circuit breaker

Protective devices are to be provided against phase-to-phase faults in the cables connecting the generators to the main switchboard and against interwinding faults within the generators. The protective devices are to trip the generator circuit breaker and to automatically de-excite the generator.

In distribution systems with a neutral earthed, phase to earth faults are also to be treated as above.

18.2.4.2 Faults to earth

Any earth fault in the system is to be indicated by means of a visual and audible alarm.

In low impedance or direct earthed systems provision is to be made to automatic disconnect the faulty circuits. In high impedance earthed systems, where outgoing feeders will not be isolated in case of an earth fault, the insulation of the equipment is to be designed for the phase to phase voltage.

Earthing factor is defined as the ratio between the phase to earth voltage of the health phase and the phase to phase voltage. This factor may vary between (1/1.73) and 1.

A system is defined effectively earthed (low impedance) when this factor is lower than 0.8. A system is defined non-effectively earthed (high impedance) when this factor is higher than 0.8.

18.2.4.3 Power transformers

Power transformers are to be provided with overload and short circuit protection.

When transformers are connected in parallel, tripping of the protective devices at the primary side has to automatically trip the switch connected at the secondary side.

18.2.4.4 Voltage transformers for control and instrumentation

Voltage transformers are to be provided with overload and short circuit protection on the secondary side.

18.2.4.5 Fuses

Fuses are not to be used for overload protection.

18.2.4.6 Low voltage systems

Lower voltage systems supplied through transformers from high voltage systems are to be protected against overvoltages. This may be achieved by:

- direct earthing of the lower voltage system
- appropriate neutral voltage limiters
- earthed screen between the primary and secondary windings of transformers.

18.3 ROTATING MACHINERY

18.3.1 Stator windings of generators

Generator stator windings are to have all phase ends brought out for the installation of the differential protection.

18.3.2 Temperature detectors

Rotating machinery is to be provided with temperature detectors in their stator windings to actuate a visual and audible alarm in a normally attended position whenever the temperature exceeds the permissible limit.

If embedded temperature detectors are used, means are to be provided to protect the circuit against overvoltage.

18.3.3 Tests

In addition to the tests normally required for rotating machinery, a high frequency high voltage test in accordance with IEC 60034-15:2009 is to be carried out on the individual coils in order to demonstrate a satisfactory withstand level of the inter-turn insulation to steep fronted switching surges.

18.4 POWER TRANSFORMERS

18.4.1 General

Dry type transformers have to comply with IEC Publication 60076-11:2018. Liquid cooled transformers have to comply with the applicable Parts of the IEC 60076 Series. Oil immersed transformers are to be provided with the following alarms and protections:

- liquid level (Low)-alarm
- liquid temperature (High)-alarm
- liquid level (Low)-trip or load reduction

- liquid temperature (High)-trip or load reduction
- gas pressure relay (High)-trip

18.5 CABLES

18.5.1 General

Cables are to be constructed in accordance with the IEC 60092-353:2016 and 60092-354:2020 or other equivalent Standard.

18.6 SWITCHGEAR AND CONTROLGEAR ASSEMBLIES

18.6.1 General

Switchgear and controlgear assemblies are to be constructed according to the IEC 62271-200:2011 and the following additional requirements.

18.6.2 Construction

18.6.2.1 Mechanical construction

Switchgear is to be of metal — enclosed type in accordance with IEC 62271-200:2011 or of the insulation — enclosed type in accordance with the IEC 62271-201:2014.

18.6.2.2 Locking facilities

Withdrawable circuit breakers and switches are to be provided with mechanical locking facilities in both service and disconnected positions. For maintenance purposes, key locking of withdrawable circuit breakers and switches and fixed disconnectors is to be possible.

Withdrawable circuit breakers are to be located in the service position so that there is no relative motion between fixed and moving portions.

18.6.2.3 Shutters

The fixed contacts of withdrawable circuit breakers and switches are to be so arranged that in the withdrawable position the live contacts are automatically covered.

Shutters are to be clearly marked for incoming and outgoing circuits. This may be achieved with the use of colours or labels.

18.6.2.4 Earthing and short-circuiting

For maintenance purposes an adequate number of earthing and short-circuiting devices is to be provided to enable circuits to be worked upon with safety.

18.6.2.5 Internal arc Classification (IAC)

Switchgear and controlgear assemblies shall be internal arc classified (IAC). Where switchgears are accessible by authorized personnel only Accessibility Type A is sufficient (IEC 62271-200:2011; Annex AA; AA 2.2). Accessibility Type B is required if accessible by non-authorized personnel.

Installation and location of the switchgear shall correspond with its internal arc classification and classified sides (F, L and R).

18.6.3 Auxiliary systems

18.6.3.1 Source and capacity of supply

If electrical energy and/or physical energy is required for the operation of circuit breakers and switches, a store supply of such energy is to be provided for at least two operations of all the components.

However, the tripping due to overload or short-circuit, and under-voltage is to be independent of any stored electrical energy sources. This does not preclude shunt tripping provided that alarms are activated upon lack of continuity in the release circuits and power supply failures.

18.6.3.2 Number of external supply sources

When external source of supply is necessary for auxiliary circuits, at least two external sources of supply are to be provided and so arranged that a failure or loss of one source will not cause the loss of more than one generator set and/or set of essential services.

Where necessary one source of supply is to be from the emergency source of electrical power for the start up from dead ship condition.

18.6.4 High voltage test

A power-frequency voltage test is to be carried out on any switchgear and controlgear assemblies. The test procedure and voltages are to be according to the IEC 62271-200:2011 section 7 / routine test.

18.7 INSTALLATION

18.7.1 Electrical equipment

Where equipment is not contained in an enclosure but a room forms the enclosure of the equipment, the access doors are to be so interlocked that they cannot be opened until the supply is isolated and the equipment earthed down.

At the entrance of the spaces where high-voltage electrical equipment is installed, a suitable marking is to be placed which indicates danger of high-voltage. As regard the high-voltage electrical equipment installed out-side a.m. spaces, the similar marking is to be provided.

An adequate, unobstructed working space is to be left in the vicinity of high voltage equipment for preventing potential severe injuries to personnel performing maintenance activities. In addition, the clearance between the switchboard and the ceiling/deckhead above is to meet the requirements of the Internal Arc Classification according to IEC 62271-200:2011 (see 18.6.2.5).

18.7.2 Cables

18.7.2.1 Runs of cables

In accommodation spaces, high voltage cables are to be run in enclosed cable transit systems.

18.7.2.2 Segregation

High voltage cables are to be segregated from cables operating at different voltage ratings each other; in par-

ticular, they are not to be run in the same cable bunch, nor in the same ducts or pipes, or, in the same box.

Where high voltage cables of different voltage ratings are installed on the same cable tray, the air clearance between cables is not to be less than the minimum air clearance for the higher voltage side in item 18.2.3.1. However, high voltage cables are not to be installed on the same cable tray for the cables operating at the nominal system voltage of 1 kV and less.

18.7.2.3 Installation arrangements

High voltage cables, in general, are to be installed on cable trays when they are provided with a continuous metallic sheath or armour which is effectively bonded to earth; otherwise they are to be installed for their entire length in metallic castings effectively bonded to earth.

18.7.2.4 Terminations

Terminations in all conductors of high voltage cables are to be, as far as practicable, effectively covered with suitable insulating material. In terminal boxes, if conductors are not insulated, phases are to be separated from earth and from each other by substantial barriers of suitable insulating materials.

High voltage cables of the radial field type, i.e. having a conductive layer to control the electric field within the insulation, are to have terminations which provide electric stress control.

Terminations are to be of a type compatible with the insulation and jacket material of the cable and are to be provided with means to ground all metallic shielding components (i.e. tapes, wires etc.).

18.7.2.5 Marking

High voltage cables are to be readily identifiable by suitable marking.

18.7.2.6 Test after installation

Before a new high voltage cable installation, or an addition to an existing installation, is put into service a voltage withstand test is to be satisfactorily carried out on each completed cable and its accessories.

The test is to be carried out after an insulation resistance test.

For cables with rated voltage (U_0/U) above 1.8/3 kV ($U_m=3.6$ kV) an a.c. voltage withstand test may be carried out upon advice from high voltage cable manufacturer. One of the following test methods to be used:

- a) test for 5 min with the phase-to-phase voltage of the system applied between the conductor and the metallic screen/sheath;
- b) test for 24h with the normal operating voltage of the system.

Alternatively, a d.c. test voltage equal to 4 U_0 may be applied for 15 minutes.

For cables with rated voltage (U_0/U) up to 1.8/3 kV ($U_m=3.6$ kV) a d.c. voltage equal to 4 U_0 shall be applied for 15 minutes.

After completion of the test, the conductors are to be connected to earth for a sufficient period in order to remove any trapped electric charge.

An insulation resistance test is then repeated.

19 SPECIAL REQUIREMENTS FOR ELECTRICAL EQUIPMENT WITH RESPECT TO SHIP PURPOSE

The present requirements shall be considered as amendments to the relevant requirements referred to in Section 1-17 of the present Part of the Rules.

19.1 PASSENGER SHIPS

19.1.1 Supply and signalling

19.1.1.1 Electrical drives of sea-water pumps, air compressors and control-and-signalling devices of automatic sprinkler systems and other firefighting systems shall be supplied directly from the main and the emergency switchboards by separate feeder. These feeders shall be connected to an automatic change-over switch fitted near the sprinkler system pump.

This switch, normally, shall be connected to the feeder from the main switchboard and in the case of supply failure it shall automatically switch over to the supply feeder from the emergency switchboard. The switches of all feeders on the main and emergency switchboards shall be clearly marked and permanently in the "on" position. No other switches shall be fitted in these current circuits.

19.1.1.2 Supply cables of electrical drive for sea-water pumps, air compressors and control-and-signalling devices of automatic sprinkler systems shall not run through machinery casings, galleys and other enclosed spaces of high fire risk, except where fire resistant type cables are provided or the above devices and machines are installed in such spaces.

19.1.1.3 The lighting fixtures in saloons, stairways, passages and corridors to the boat deck shall be supplied through at least two independent feeders (see 6.2.3).

19.1.1.4 The supply of the essential consumers shall be so arranged that a fire in one of the main fire zones will not damage the supply system in another main fire zone.

This requirement may be considered satisfied if the supply feeders from main and emergency switchboards running through main fire zones are laid as distant from each other as possible, both vertically and horizontally.

19.1.1.5 General alarm system shall consist of two independent groups: one for the crew and the other for passengers.

In ships with low power electrical installation, one group of general alarm is permitted.

19.1.2 Supply from emergency sources of electrical power

19.1.2.1 Emergency source of electrical power in passenger ships of unrestricted area of navigation 1 and that of restricted area 2, shall simultaneously and continuously supply during 36 hours the following services:

- .1 emergency lighting for:

- embarkation station on deck and over sides where life-saving appliances are launched;
 - indicators of exits to the boat deck and notice-plates at the life-saving appliances;
 - exits from the spaces where a large number of passengers, special personnel or crew members can be simultaneously;
 - passages, stairways to accommodations and service spaces, exits to open decks as well as to passenger elevators;
 - machinery spaces and spaces with main sources of electrical power including their local control consoles;
 - all control consoles as well as main and emergency switchboards;
 - emergency diesel generator space;
 - navigating bridge;
 - radio rooms and chartrooms;
 - stowage room for emergency and fireman's outfit and manual fire alarms;
 - steering gear compartment;
 - locations of attendance to emergency fire and bilge pumps, sprinkler pumps as well as locations where the pumps motor starters are installed;
 - helicopter hangers and landing areas;
 - gyrocompass space;
 - medical space;
- .2 navigation lamps, lamps giving signals of difficulties in navigation and other lamps required by the International Regulations for Preventing Collision at Sea in force;
 - .3 radio equipment and navigational equipment in accordance with the requirements of the SOLAS 74 Ch. IV, and SOLAS 74 Ch. V according to the international conventions for the ship's equipment
 - .3.1 VHF radio-installation,
 - .3.2 MF - radio-installation,
 - .3.3 Ship earth station,
 - .3.4 MF/HF radio-installation,
 - .4 internal communication, announcing and emergency general alarm systems;
 - .5 fire detection system, fire door control device and indicators showing the position of fire doors as referred to in the *Rules for the classification of ships, Part 17 - Fire protection*.
 - .6 daylight signalling lamps, audible signal means, manual call signals and other signal devices in emergency conditions;
 - .7 fire and sprinkler pumps and electrical equipment supplying foam generators referred to in the *Rules for the classification of ships, Part 17 - Fire protection*.
 - .8 emergency bilge pump and equipment essential for operation of remote-controlled bilge valves;

- .9 the auxiliary equipment for the emergency diesel generator;
- .10 other systems considered by the *Register* to be vital for ensuring the safety of the ship and persons on board.

Consumers referred to in 19.1.2.1.1 to 19.1.2.1.6 may be fed from their own accumulator batteries located according to 9.2, and having a capacity sufficient for their supply for a period of 36 hrs.

For ships of restricted navigational area 3, the period of 36 hrs may be reduced to 18 hrs and for ships of restricted navigational area 4, 5, 6, 7, 8 it may be reduced to 3 hrs.

19.1.2.2 Emergency source of electrical power shall ensure the supply of steering gear in accordance with 5.5.6.

19.1.2.3 Continuous supply shall be ensure for 3 hours on Ro/Ro passenger ships the supplementary emergency illumination with own storage-battery luminaries, see 19.3.3.

19.1.2.4 Emergency source of electrical power shall be ensure continuous supply from period of one hour for electric operated Low-Location Lighting (LLL-system).

19.1.2.5 Emergency source of electrical power shall ensure the continuous supply of the following consumers for 30 min:

- .1 electrical drives of watertight doors together with their indicators and devices for pre-warning signals for closure. Sequential closing of the doors may be permitted provided that all doors can be closed within 60 s;
- .2 passenger elevator drives.
It is permitted to start the elevators one after the other.

19.1.2.6 Where a diesel generator serves as the emergency source of electrical power, it shall be:

- .1 driven by an internal combustion engine in compliance with the *Rules for the classification of ships, Part 9 - Machines*, Section 2.
- .2 automatically started in case of voltage loss on the busbars of the main switchboard and switched over to emergency switchboard.

The total time for starting the generator and taking over the load shall not exceed 45 sec.

Consumers referred to in 19.1.2.7 shall be automatically switched over to the emergency source of electrical power:

- .3 provided the transitional source of electrical power which shall be activated immediately upon the voltage loss in the main switchboard.

19.1.2.7 Where an accumulator battery serves as the emergency source of electrical power, it shall:

- .1 operate under load without re-charging and with voltage drop within ± 12 percent of the rated voltage during the whole discharge period,

- .2 in case of voltage loss on the main switchboard busbars, be automatically connected to the busbars of the emergency switchboard and supply at least the services listed under 19.1.2.7.

19.1.2.8 The transitional emergency source of electrical power required by 19.1.2.6.3, shall be an accumulator battery which shall operate without re-charging within ± 12 percent of rated voltage.

19.1.2.9 The capacity of the battery serving as a transitional emergency source of electrical power, shall be sufficient for supplying the services listed below during 30 min.:

- .1 lighting according to 19.1.2.1.1 and 19.1.2.1.2;
- .2 internal communication and public address system required in an emergency;
- .3 fire alarm system, fire detection and control devices of fire doors and indicators showing the position of fire doors referred to in the *Rules for the classification of ships, Part 17 - Fire protection*.
- .4 daylight signalling lamps, sound signal means, engineer's call system activated manually as well as other types of signals required under emergency conditions;
- .5 arrangements for closing watertight doors, including position indicators and pre-warning devices of their closing.
Closing of all these doors shall not be simultaneously.
Consumers referred to under subsection 2,3 and 4 may be supplied from their own accumulator batteries, provided that they are capable to ensure their supply during the required time.

19.1.2.10 Where the emergency and/or transitional emergency loads are supplied from a battery via an electronic converter the maximum permitted d.c. voltage variations are to be taken as those the load side of the converter or inverter.

Where the d.c. converted into a.c. the maximum variation are not exceed those given in 2.1

19.1.3 Low-location lighting (LLL system)

19.1.3.1 All escape routes including stairs and exits shall be provided at all points on the route including the corners and intersections with electrically operated or photoluminescent low-location lighting, installed not more than 0,3 m above the deck. The low-location lighting shall enable the passengers to identify all escape routes and to recognise the emergency exits easily.

19.1.3.2 Electrically operated LLL system shall be supplied from the emergency electrical power system and so arranged that a failure of a single light or cut in a lighting strip will not result in the marking being ineffective.

19.1.3.3 The design of electrically operated LLL system must be made in accordance with the technical requirement of IMO resolution A.752(18) and ISO Standard 15370:2001-04-15.

19.1.4 Supplementary lighting

In passenger ships, supplementary lighting shall be provided in all cabins to clearly indicate the exit so that occupants will be able to find their way to the door. Such lighting which may be connected to an emergency source of power or have a self-contained source of electrical power in each cabin, shall automatically illuminate when power to the normal cabin lighting is lost and remain on for a minimum of 30 minutes.

19.2 OIL TANKERS AND OIL RECOVERY SHIPS

19.2.1 General provisions

The requirements of this Section apply to the electrical equipment of oil tankers intended for the carriage of liquids having a flash point $\leq 60^{\circ}\text{C}$ or liquids having a flash point $> 60^{\circ}\text{C}$ (closed cup test) for which heating is required up to a temperature within 15°C of its flash point and also the electrical equipment of ships intended for the recovery and transporting of oil spill on the sea surface, and they are set forth in addition to the requirements referred to in other Sections of the present Rules, in particular to those in section 2.9.

For oil tankers, for condition as specified in this item have to be according to IEC 60092-502:1999.

19.2.2 Distribution of electrical power

19.2.2.1 The following systems for distribution of electrical power may be used:

- .1 direct current two-wire insulated system,
- .2 single-phase, two-wire insulated system,
- .3 three-phase, three-wire insulated system (also for voltages from 1000 V up to 11000 V).
- .4 three-phase, three-wire system with neutral earthed through high resistance for voltages between 1000 V and 11000 V (see 2.9.9).

19.2.2.2 Earthed systems of electrical power distribution may be permitted only for supply of consumers listed below provided that they are located outside hazardous spaces and zones:

- .1 impressed-current cathodic protection system for external hull protection against corrosion;
- .2 system for insulation resistance measurement and monitoring (see 4.6.4.7).
- .3 system for electrical starting of internal combustion engines.

19.2.3 Spaces and areas with high explosion risk

19.2.3.1 Following spaces and areas are with risk of explosion which is likely to occur:

Zone 0:

- .1 internal cargo compartments and tanks, cargo piping and transfer system;

Zone 1:

- .2 open areas at a height up to 1m above oil-covered water surface (for oil recovery ships);
- .1 cofferdams and other spaces adjoining cargo compartments and tanks;
- .2 enclosed and semi-closed spaces containing cargo pumps and cargo piping provided the latter are not all-welded;
- .3 enclosed and semi-enclosed spaces above the deck of cargo compartments and tanks as well as other spaces which have their bulkheads above or in level with the bulkheads of the cargo compartments and tanks;
- .4 enclosed and semi-enclosed spaces above cargo pump rooms and also above vertical cofferdams adjoining cargo compartments and tanks unless separated by a gastight deck and provided with forced ventilation;
- .5 areas and spaces other than cofferdams adjoining cargo compartments and tanks and located below cargo compartment and tank top level;
- .6 areas and semi-enclosed spaces on the open deck within a radius of 3m from ventilation outlets, cargo tank manholes and hatches, pump rooms and cofferdams adjoining the cargo tanks;
- .7 areas on the open deck above cargo compartments and tanks (including ballast tanks when used as cargo tanks) over the full width of the ship and 3m fore and aft of their boundary bulkheads up to a height of 2,4 m above the deck.
For oil recovery ships, this area extends to the full length of the ship;
- .8 **A1** - Areas on open deck, or semi-enclosed spaces on open deck, within 3m of cargo tank ventilation outlets which permit the flow of small volumes of vapour or gas mixtures caused by thermal variation are defined as Zone 1 as specified by IEC 60092-502:1999 para. 4.2.2.7;
- .9 **B1** - Areas on open deck, or semi-enclosed spaces on open deck, within a vertical cylinder of unlimited height and 6m radius centred upon the centre of the outlet, and within a hemisphere of 6m radius below the outlet which permit the flow of large volumes of vapour or gas mixtures during loading/discharging/ballasting are defined as Zone 1 as specified by IEC 60092-502:1999 para 4.2.2.8;
- .10 storage spaces for cargo hoses and equipment for collecting spilt oil;
- .11 enclosed or semi-enclosed spaces having exits or other openings directly into one of the above areas and spaces;
- .12 spaces and areas above cofferdams adjoining cargo compartments and tanks and separated from them by oil and gastight bulkheads and decks not adequately ventilated and entered from an upper deck;

- .13 spaces with electrical motors of cargo pumps and stripping pumps and which are located above pump rooms.

Zone 2:

- .1 Areas above zone 1 over the full width and length of the ship to a height of 6m above the deepest load waterline (for oil recovery ships);
- .2 **A2** - Areas within 2m beyond the zone specified in A1 above are to be considered Zone 2 (as opposed to 1.5m as specified by IEC 60092-502:1999 para 4.2.3.1);
- .3 **B2** - Areas within 4m beyond the zone specified in B1 above are defined as Zone 2 as specified by IEC 60092-502:1999 para 4.2.3.2.

Spaces and areas not included in zones 0, 1 and 2 are considered safe.

19.2.3.2 Where cargo tank deck is extending to the accommodation bulkhead, spaces referred to in 19.2.3.1.7 shall be determined so that the height of an overflow coming is at least equal to that of the side coming which preclude the overflow of liquid cargo from deck.

In this case the hazardous zone shall extend up to 3m from the overflow coming.

19.2.3.3 Spaces below the upper deck having the direct access or other openings into spaces on the upper deck in compliance with 19.2.3.1.7 shall not be considered as hazardous, provided double self-closing, gastight doors are fitted forming an air lock as well as forced ventilation with air suction from locations outside hazardous zones.

19.2.3.4 In oil recovery ships, ventilation openings and other openings into spaces which are not hazardous (such as accommodations, service spaces, control stations and navigating bridge) which have no gastight doors, shall not be located more than 6 m below the deepest waterline and, under all circumstances, shall be outside hazardous zones.

Entrances to safe spaces laying more than 6m below the deepest waterline or within hazardous zones shall be provided with air locks.

Openings to such spaces more than 6m below the waterline shall have gastight closures.

19.2.3.5 Electrical equipment, cables and wiring shall not be installed in hazardous locations unless it conforms with standards not inferior to those acceptable to the *Register* - IEC 60092-502:1999. However, for locations not covered by such standards, electrical equipment, cables and wiring which do not conform to the standards may be installed in hazardous locations based on a risk assessment to the satisfaction of the *Register*, to ensure that an equivalent level of safety is assured.

Where the prescriptive requirements within SOLAS and related Codes (IBC, IGC) and the standards published by the International Electrotechnical Commission, such as but not limited to IEC 60092-502, are not aligned, the prescriptive requirements in SOLAS and Codes take precedence and are to be applied (see UI SC274).

19.2.4 Electrical equipment in hazardous spaces and zones

19.2.4.1 In hazardous spaces only safe-type (explosion-proof) electrical equipment shall be permitted provided that such equipment is designed, manufactured and tested in compliance with IEC 60079 Series and if the Certificate of type testing issued by the respective Authorities is provided:

- .1 lighting fixtures and navigational lanterns with pressurised enclosures (Exp), with flameproof enclosure (Exd) or with increased safety type (Exe);
- .2 junction boxes of increased safety type (Exe) or with flameproof enclosure (Exd);
- .3 Control, monitoring, remote-control and communication equipment of intrinsically safe type (Exi);
- .4 electrical motors:
 - with flameproof enclosure (Exd)
 - at increased safety type (Exe);
 - with pressurised enclosure (Exp)

19.2.4.2 In compartments and cargo tanks, cargo piping and transfer systems only intrinsically safe type (Exi) electrical equipment may be installed.

19.2.4.3 In open spaces extending up to 1m above oil covered water surface, in oil-recovery ships, only intrinsically safe type (Exi) electrical equipment may be installed.

19.2.4.4 In double bottom and spaces separating cofferdams and cargo tanks no electrical equipment shall be permitted except for the following:

- .1 intrinsically safe devices (Exi);
- .2 echo-sounder transducers and the associated cables;
- .3 cables of impressed current cathodic protection system for external hull protection installed in steel gastight, corrosion-resistant pipes up to the main deck.

19.2.4.5 In enclosed and semi-enclosed spaces containing cargo pumps or cargo piping, only the following may be installed.

- .1 electrical equipment referred to in 19.2.4.1.1 to 19.2.4.1.3;
- .2 lighting fixtures fed by at least two independent circuits with fuses and switches in all phases, located outside hazardous spaces and zones.

The following types of the equipment are permitted:

- lighting by means of fixtures arranged outside the hazardous spaces and zones through glazed non-opening parts in gastight bulkheads and decks provided they do not impair strength, gastight or fire integrity of these bulkheads or decks;
- lighting fixtures of safe type with pressurised enclosure (Exp) or flameproof enclosure (Exd) which cables shall be protected with metal armour against mechanical damage;
- .3 cables laid through for the above devices

The electrical motors driving the equipment located in pump rooms shall be installed in adjacent spaces without explosion risk. For the shaft penetrations through bulkheads or decks gastight stuffing boxes shall be provided. The electrical motors shall be provided with remote disconnecting switches fitted outside the space where the motors are installed and above the cargo tank deck a temperature transmitters with overheating control and audible and visual alarm in the cargo control room or the pump control station shall be fitted on glands, shaft bearings and pumps casings.

Lighting fixtures in cargo pump spaces shall be interlocked together with ventilation so that the lighting shall be switched on only if ventilation is activated.

This requirement does not apply to the emergency lighting. Failure at the ventilation system shall not cause lighting to go out.

19.2.4.6 In enclosed and semi-enclosed spaces above the cargo tank deck and in spaces where bulkheads are above or in level with the cargo tank and cargo compartment bulkheads, in enclosed or semi-enclosed spaces above the cargo pumps rooms and above vertical cofferdams adjoining cargo compartments and tanks, unless separated by gastight deck and provided with forced ventilation, in compartments with cargo transfer piping and equipment for collecting spilt oil, the following may be installed:

- .1 intrinsically safe equipment (Exi);
- .2 safe-type lighting fixtures the switches of which shall be located outside the hazardous spaces and zones, designed with:
 - pressurised enclosures (Exp);
 - flame proof enclosures (Exd);
 - increased safe type (Exe);
- .3 cables laid through for the above devices.

19.2.4.7 In spaces and zones other than cofferdams adjoining cargo compartments and tanks and extending to their upper edge, the following may be installed:

- .1 electrical equipment referred to in 19.2.4.4;
- .2 safe-type lighting fixtures which are fed by at least two independent supply circuits with fuses and switches installed in all phases, located outside the hazardous spaces;
- .3 cables laid through for the above devices.

19.2.4.8 In spaces and semi-enclosed spaces on the open deck within 3 m of cargo tank hatchways and other non-ventilation openings, the following may be installed only:

- .1 electrical equipment referred to in 19.2.4.1;
- .2 cable runs in conduits or pipes without compensation loops.

19.2.4.9 In the open deck spaces above cargo compartments and tanks (including ballast tanks, when used as cargo tanks) to the full width of the ship plus 3m fore and aft up to the height of 2,4 m above the deck, as well as in enclosed and

semi-enclosed spaces with direct access or other openings into one of the above spaces, may be installed:

- .1 electrical equipment referred to in 19.2.4.1;
- .2 cable runs in conduits or pipes without compensation loops.

19.2.4.10 Areas on open deck within 3 m of cargo tank openings for pressure release provided to permit the flow of small volumes of gas or vapour mixture caused by thermal variation, the following equipment may be installed:

- .1 electrical equipment referred in 19.2.4.1;
- .2 cable runs in conduits or pipes without compensation loops.

19.2.4.11 Areas on open deck inside a cylinder of unlimited height of 6 m radius around and above gas outlets for the passage of large volumes of gas or vapour mixture during cargo loading and ballasting or during discharging, the following equipment may be installed:

- .1 electrical equipment referred in 19.2.4.1;
- .2 cable runs in conduits or pipes without compensation loops.

19.2.4.12 In spaces and zones above cofferdams adjoining cargo compartments and tanks, not separated by gastight bulkheads or decks and having no adequate ventilation and which have an access from the upper deck, the following equipment may be installed:

- .1 safe-type lighting fixture;
- .2 devices without sparking during operation and external surfaces which are not likely to be overheated.
- .3 increased safe-type equipment (Exe) ventilated with mechanical protection degree of at least IP55 and external surfaces which are not likely to be overheated.

19.2.4.13 In spaces containing electrical motor drives of cargo pumps and stripping pumps located above the pump rooms, the following equipment may be installed:

- .1 safe-type lighting fixtures;
- .2 equipment not sparking during operation and whose external surfaces are not likely to be overheated;
- .3 increased safe-type equipment (Exe), ventilated with mechanical protection degree of at least IP55 and whose external surfaces are not likely to be overheated.

Where the arrangement or structure of spaces may result in accumulation of explosive mixtures of vapours, gases and dusty air, effective ventilation shall be provided.

Besides, an interlock shall be provided between the starting devices of the cargo pump electrical motors and the electrical drive of the space ventilation in order to prevent the cargo pump starting prior to sufficient ventilation space.

19.2.4.14 The possibility shall be considered of accumulation of explosive mixtures of gas and air during cargo transfer, degassing the tanks and balloting outside the spaces and zones referred to in 19.2.3.1.1 to 19.2.3.1.13.

The design of electrical equipment being in service during the above operations such as lighting fixtures, winches, equipment installed in navigating bridge wings, etc. shall be such that no arcs or sparks are formed and the external surfaces of equipment are not overheated.

19.2.4.15 In spaces defined as zone 2, as referred to in 19.2.3.1, the equipment's may be installed if it's are in accordance with 2.9.14.5.

19.2.4.16 Definition of hazardous spaces for tankers less than 500 GT in navigation areas 5,6,7,8 is subject to special consideration by *Register* in each particular case.

19.2.5 Portable electrical equipment used for collecting spilt oil

19.2.5.1 Portable equipment for collecting and transfer of oil shall be of safe type.

19.2.5.2 Distribution boxes and socket outlets for supplying portable oil-collecting and transfer equipment on deck shall be fitted in such a way that cables connected to them would not pass through door coamings or other closed openings adjacent to hazardous spaces and zones.

Distribution boxes or sockets shall provide for an interlock so that the connection to portable equipment is possible only in de-energised condition. Each conductor shall be provided with the short-circuit and overvoltage protection.

19.2.5.3 Flexible cables used for portable electrical equipment intended for collecting spilt oil shall have an outer armour made of oil-resistant material as well as metal protective sheath being water proof.

19.2.6 Installation of cables

19.2.6.1 Cables installed on bridges on decks shall run in suitable conduits or pipes.

19.2.6.2 When cables are installed in conduits the following requirements shall be met:

- .1 cables shall be laid in rows on suitably shaped protective plane of non-metallic materials.

The possibility of lateral displacement of the cables shall be excluded.

Cables may be laid outside the conduits and fixed by clips which shall be approved by the *Register*, but the laying of more than two rows in this way shall not be permitted.

- .2 cables shall not be in contact with metal parts of the conduit.
- .3 cables shall not be subject to constant or variable tensile forces due to deformations of the ship's hull.

In way of detachable or sliding connections of the gangways or platforms with superstructures where it is not possible to avoid such forces, cables shall be suitably protected by means of compensation loops. The inside radius of the loop shall not be less than 10 diameters of the thickest cable.

- .4 cables shall be protected from direct exposure to solar radiation, sea waves, oil products and from mechanical damage.
- .5 cables shall be separated from source of heat by a distance referred to in 16.8.4.1.
- .6 cable trays on the passageway platform or in pipes within zones referred to in 19.2.3.1.3, including compensation loops, shall not be located below 300 mm from the cargo tank deck.
- .7 metal sheaths or armours of cables shall be earthed at both ends. For final subcircuits earthing of the metal sheath may be effected only at the supply end.

19.2.6.3 In distribution systems referred to in 19.2.2.1.4 only cables having copper screens with additional insulation covering may be used. The cross-sectional area of a screen shall be at least the cross-sectional area of a conductor.

The structure of such cables is subject to the special consideration by the *Register*.

19.2.7 Integrated cargo and ballast systems on tankers

19.2.7.1 These requirements are applicable to integrated cargo and ballast systems installed on tankers (i.e. cargo ships constructed or adapted for the carriage of liquid cargoes in bulk), irrespective of the size or type of the tanker.

Within the scope of these requirements, integrated cargo and ballast system means any integrated electric system used to drive both cargo and ballast pumps (including active control and safety systems and excluding passive components, e.g. piping).

19.2.7.2 The operation of cargo and/or ballast systems may be necessary, under certain emergency circumstances or during the course of navigation, to enhance the safety of tankers.

As such, measures are to be taken to prevent cargo and ballast pumps becoming inoperative simultaneously due to a single failure in the integrated cargo and ballast system, including its control and safety systems.

19.2.7.3 The following design features are, inter alia, to be fitted:

- .1 the emergency stop circuits of the cargo and ballast systems are to be independent from the circuits for the control systems. A single failure in the control system circuits or the emergency stop circuits are not to render the integrated cargo and ballast system inoperative;
- .2 manual emergency stops of the cargo pumps are to be arranged in a way that they are not to cause the stop of the power pack making ballast pumps inoperative;
- .3 the control systems are to be provided with backup power supply, which may be satisfied by a duplicate power supply from the main switch board. The failure of any power supply is to provide audible and visible alarm activation at each location where the control panel is fitted.

- .4 in the event of failure of the automatic or remote control systems, a secondary means of control is to be made available for the operation of the integrated cargo and ballast system. This is to be achieved by manual overriding and/or redundant arrangements within the control systems.

19.2.8 Requirements for survey of electrical equipment installed in hazardous areas on tankers

19.2.8.1 For the requirements for survey of electrical equipment installed in hazardous areas on tankers refer to IACS Recommendation No. 120.

19.3 SHIPS INTENDED FOR CARRIAGE OF MOTOR VEHICLES WITH FUEL IN THEIR TANKS, TANK CARS AND TANK WAGONS FOR FLAMMABLE LIQUIDS

19.3.1 General provisions

19.3.1.1 The requirements of this Section apply to electrical equipment of cargo holds and other spaces and zones intended for the carriage of motor vehicles with fuel in their tanks and of tank wagons and tank cars for flammable liquids, and they are set forth in addition to the preceding requirements.

19.3.1.2 Cargo holds and other spaces referred to in 19.3.1.1 belong to the category of hazardous spaces and zones.

19.3.1.3 Cables shall be protected against mechanical damage. Cables installed horizontally shall be positioned at a distance not less than 450 mm above the continuous deck or platform preventing a free propagation of gases from the downward direction.

The sealing where cables penetrate decks and bulkheads shall be gastight.

19.3.1.4 Electrical equipment installed in ventilation ducts shall be of safe type.

19.3.1.5 The lighting in cargo holds and spaces referred to in 19.3.1.1 shall be arranged at least in two groups, each supplied separately from an independent separate circuit.

19.3.2 Installation of electrical equipment in holds and spaces intended for carriage of motor vehicles with fuel in their tanks in passenger and cargo Ro-Ro ships

19.3.2.1 In cargo holds and spaces above the bulkhead deck, (at least 10 air changes/hour) in zones more than 450 mm above the deck or platform preventing a free propagation of gases from the downward direction, electrical equipment with the mechanical protection degree of at least IP55 shall be permitted.

19.3.2.2 In cargo holds and spaces above the bulkhead deck (at least 10 air changes/hour) all the electrical equipment

in zones below 450 mm from the deck or a platform preventing a free propagation of gases upwards, shall be of safe type.

19.3.2.3 In cargo holds and spaces below the bulkhead deck the electrical equipment shall be of safe type.

19.3.2.4 In exhaust ducts from cargo holds the electrical equipment shall be at safe type.

19.3.2.5 On cargo ships, cargo holds fan failure is to be indicated optically or audibly on the bridge.

19.3.3 Additional requirements for passenger ro-ro ships

19.3.3.1 Emergency lighting

19.3.3.1.1 In passenger ro-ro ships, in addition to the emergency lighting referred to in 19.1.2.1.1, special electrical lighting fixtures shall be fitted in passenger public spaces and alleyways which shall serve for 3 hrs at least under any heel of the ship when all other electrical power sources fail.

This special lighting shall make the escape routes clearly visible i.e. ensure illumination intensity of at least 0,5 lx.

19.3.3.1.2 This lighting fixtures shall be fed by accumulator batteries fitted inside the lighting fixtures together with the rectifier, connected to the emergency switchboard.

19.3.3.1.3 In each corridor of crew spaces, in crew recreation rooms and in each space where the crew members normally work, a portable lamp shall be provided supplied from an accumulator battery. This requirement may be dispensed with if corridors and spaces are provided with additional lighting in compliance with 19.3.3.1 and 19.3.3.1.2.

19.3.3.2 Signalling

19.3.3.2.1 Indicators shall be provided on the navigating bridge for all shell doors, loading doors and other closing appliances which, if left open or not properly secured could lead to major flooding of a special category space or spaces for vehicles. The indicator system shall be designed on the fail-safe principle and shall show if the door is not fully closed or not secured. The power supply for the indicator system shall be independent of the power supply for operating and securing the doors.

19.3.3.2.2 Means shall be provided, such as television surveillance or a water leakage detection system, to indicate to the navigating bridge of any leakage through bow doors, stern doors or any other cargo or vehicle loading doors which could lead to major flooding of special category spaces or ro-ro cargo spaces.

19.3.3.2.3 Special category spaces and ro-ro cargo spaces shall either be patrolled or monitored by effective means, such as television surveillance, so that movement of vehicles in adverse weather and unauthorised access by passengers can be observed while the ship is underway.

19.3.3.2.4 A fan failure or failure related to the number of air changes specified for cargo holds shall be indicated optically or audibly on the bridge.

19.3.4 Requirements for installation of electrical equipment in holds and spaces intended for carriage of motor vehicles with fuel in their tanks in cargo ships

19.3.4.1 In cargo holds and spaces in the area above 450 mm from the enclosed deck, it is permitted to install electrical equipment with the degree of mechanical protection not less than IP55 on condition that the ventilation system ensures at least 10 air changes per hour.

19.3.4.2 In cargo holds and spaces, in the area below 450 mm from the enclosed deck, it is permitted to install only electrical equipment of the safe type.

19.4 SPECIAL PURPOSE SHIPS

19.4.1 Supply of essential consumers

In special purpose ships carrying more than 50 persons of the special personnel, the supply circuits of essential consumers shall comply with the requirements referred to in 19.1.1.4.

19.4.2 Emergency sources of electrical power

19.4.2.1 In special purpose ships carrying not more than 50 persons, the emergency source of electrical power shall comply with 9.3.

Ships having a length more than 50 m shall additionally comply with 19.1.2.3.1.

19.4.2.2 In special purpose ships carrying more than 50 persons, the emergency source of electrical power shall comply with 19.1.2.

19.4.3 Electrical equipment in cargo spaces for carrying dangerous goods

19.4.3.1 Electrical equipment in cargo spaces for carrying dangerous goods, as specified in the *Rules for the classification of ships, Part 17. – Fire protection, 2.7*, have to be according to IEC 60092-506 standard, –Special features – Ships carrying specific dangerous goods and materials hazardous only in bulk.

19.4.3.2 Switches of lighting circuits shall be fitted outside store rooms for explosive materials and shall be provided with signals to indicate the presence of voltage in the lighting fixtures.

19.4.3.3 In store rooms for explosive materials, the devices for connection of portable electrical equipment to the ship's mains shall be provided with name plates indicating the rated electrical parameters and shall have the degree of mechanical protection of at least IP56.

19.5 CONTAINER SHIPS

19.5.1 General provisions

The requirements of this section apply to electrical equipment of ships intended for carriage of isotherm containers.

19.5.2 Supply and distribution of electrical power

19.5.2.1 The installed power of the isotherm containers shall be taken as their rated power. The consumed power of the electrical equipment of isotherm containers shall not exceed 15 kW/18,75 kVA under normal operating conditions.

The application of correction factors is subject to special consideration by the *Register* in each particular case.

19.5.2.2 The overload protective devices of electrical power sources referred to in 8.2.3 shall ensure disconnection of isotherm containers from the main switchboard in the last turn (see 20.2.1).

19.5.2.3 The electrical circuits supplying the group of isotherm containers shall be separated from the ship's main by transformers with separate windings.

This transformer shall be fed from the main switchboard.

19.5.2.4 The electrical installations of isotherm containers shall be fed from special distribution boards supplied by separate feeders.

19.5.2.5 Socket outlets installed in cargo holds or in open decks in areas of the isotherm container stowage, shall be supplied by separate feeders from special distribution boards (see 19.5.2.4 and 19.5.3.3).

19.5.2.6 The socket outlets intended for supply of isotherm containers shall be rated for 220 or 380 V at 3-phase, 50 Hz in frequency, or 240 and 440 V at 3-phase, 60 Hz in frequency.

19.5.3 Distribution boards and transformers

19.5.3.1 Distribution boards for supplying isotherm containers, electrical converters, if fitted, and transformers with separate windings shall be installed in special electrical spaces.

19.5.3.2 The secondary windings of transformers with separate windings shall have an isolated zero point.

19.5.3.3 Each distribution board shall be equipped with appliances to ensure:

- .1 visible signalling to indicate the presence of voltage;
- .2 connection and disconnection of each outgoing feeder supplying the socket outlets;
- .3 short-circuit protection of the outgoing socket feeders outlets;
- .4 measurement of insulation resistance.

19.5.4 Socket outlets

19.5.4.1 In cargo holds containing isotherm containers, socket outlets used only for power supply of containers shall be permitted.

The degree of mechanical protection shall be not less than IP55 and on open decks, IP56 .

For the remote control of temperature, humidity, ventilation and other characteristics of isotherm containers in holds or decks, additional socket outlets shall be permitted for their connection.

19.5.4.2 Socket outlets for power supply of the electrical equipment of isotherm containers shall comply with the requirements of 14.2.3 and shall, in addition, be fitted with switch interlocked so that the plug cannot be inserted or withdrawn while the switch is in the "on" position. A nameplate indicating the voltage level shall also be fitted.

19.5.4.3 The electrical installation of isotherm containers shall be supplied from the ship's main at the direct sequence of phases R(A); S(B); T(C), as shown in the scheme:

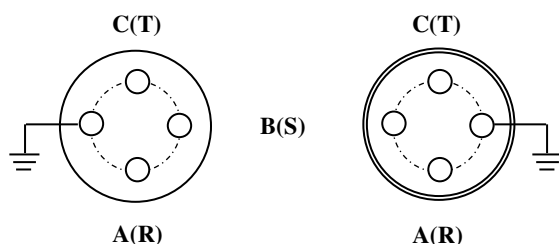

Fig. 19.5.4.3

19.5.4.4 Socket outlets intended for supply of the isotherm containers shall be rated at the following currents:

- 63 A for voltage of 220 V, 50 Hz and 240 V, 60 Hz
- 32A for voltage of 380 V, 50 Hz and 440 V, 60 Hz

19.5.4.5 Socket outlets and plugs shall be so designed as to prevent insertion of plugs rated for one voltage to socket outlets rated for another voltage.

19.5.4.6 Design and dimensions of plugs and sockets shall correspond to international standards.

19.5.5 Protective earthing

The receptacle intended for connection of the earthing conductor in the flexible cable of the isotherm container shall be grounded through the earthing conductor in the supply cable where the distribution board is installed to supply socket outlets of isotherm container.

19.6 CATAMARANS

19.6.1 In each hull of the ship, at least one main source of electrical power shall be provided.

19.6.2 In each hull of the ship, a main switchboard shall be provided. If one board is installed it shall be located above the bulkhead deck.

19.6.3 When one switchboard is provided only, the busbars supplying the ship's hulls shall be sectioned.

19.6.4 The emergency consumers of each hull shall be supplied from the emergency source of electrical power through separate feeders.

19.6.5 The switches for switching – off the electrical drives referred to in 5.7.1, 5.7.2, 5.8.2 and 5.8.3 shall be separated for each hull.

19.7 FLOATING CRANES AND CRANE SHIPS

19.7.1 Where requirements of the *Rules for the classification of ships, Part 17 - Fire protection*, are applicable to crane machinery of floating cranes and crane ships, they shall be applied to the extent agreed with the *Register*.

19.7.2 For self-driven floating cranes, the power of the main source of electrical energy shall meet the requirements both for the crane underway or cargo handling operations.

19.7.3 Accumulator rooms or accumulator boxes and spaces containing emergency sources of electrical power may be located below the bulkhead deck, taking into account the requirements in 9.2 and 13.2.

19.7.4 A sound signal means shall be fitted in the operator's cabin to produce sound signal during cargo handling operation.

19.7.5 Telephone connection shall be provided between the wheelhouse and the operator's cabin.

19.8 BULK CARRIERS

19.8.1 Generally

The requirements of this Section apply to electrical equipment of detection water level in bulk carriers cargo holds, dry and void space.

19.8.2 Bulk carriers shall be fitted with water level detectors.

19.8.2.1 In each cargo hold, giving audible and visual alarms, one when the water level above the inner bottom in any holds reaches a height of 0,5 m and another at a height not less than 15% of the cargo hold but not more than 2 m. The water level detectors shall be fitted in the aft end of the cargo holds. For cargo holds which are used for water ballast, an alarm overriding device may be installed.

The visual alarms clearly discriminate between the two different water levels detected in each holds.

19.8.2.2 In any ballast tank forward of collision bulkhead required with the *Rules for the classification of ships, Part 2. – Hull*, giving an audible and visual alarm when the water in the tank reaches a level not exceeding 10% of the tank capacity. An alarm overriding device may be installed to be activated when the tank is in use.

19.8.2.3 In dry or void space other than a chain cable locker, any part of which extends forward of the foremost cargo hold, giving an audible and visual alarm at water level of 0.1 m above the deck. Such alarms need not be provided in enclosed spaces the volume of which does not exceed 0,1% of the ship's maximum displacement volume.

19.8.3 The audible and visual alarms specified in item 19.8.2 shall be located on the navigation bridge and comply to IMO "Code of Alarms and Indicators, 1995".

19.8.4 Protection of enclosures of electrical components installed in cargo holds, ballast tanks, dry spaces are to be less than IP68.

19.8.5 Electrical equipment installed in cargo holds intended for use with cargoes that required protection against ignition caused by electrical installation are to be certify safe type.

19.8.6 Performance standard of electrical equipment (detectors, alarms panel) are to be in according to IMO Resolution MSC.188(79) and requirements of IACS UI SC 180.

20 REQUIREMENTS FOR ELECTRICAL EQUIPMENT OF REFRIGERATING PLANTS

20.1 GENERAL

The requirements of this Section apply to electrical equipment of the classed refrigerating plants in addition to the requirements referred to in other Section of this Rules.

The requirements of 20.2.3, 20.2.4, 20.3.1 and 20.4 apply to the unclassified refrigerating plants.

20.2 POWER SUPPLY AND CONTROL

20.2.1 The electrical drives of refrigerating plants shall be supplied through separate feeders from the distribution board of the refrigerating plant.

The electrical drives of refrigerating compressors may be supplied directly from the main switchboard. The refrigerating fans may be supplied from the distribution board of the refrigerating plant or other distribution boards supplied directly from the main switchboard.

In any case it is necessary to provide that when generator is overloaded, the refrigerating plant electrical drives are disconnected in the last turn.

The emergency ventilation system shall be supplied through a separate feeder from the distribution board supplied from the main switchboard or directly from the main switchboard.

20.2.2 Electrical drives of isotherm containers shall be supplied in compliance with 19.5.2.

20.2.3 When using the refrigerants of group II in compliance with the *Rules for the classification of ships, Part 11 - Refrigerating Plants*, Table 2.2.1, devices shall be provided for emergency remote disconnection of the refrigerating plant distribution board:

- .1 from the control post of the refrigerating plant in the refrigerating machinery room;
- .2 from a location outside the space that may be contaminated with the refrigerant of group II in case of breakdown in the refrigerating machinery room;
- .3 outside, near every exit from the refrigerating machinery room.

The devices for the remote disconnection shall be so arranged, that there is no possibility of their unintentional activation.

20.2.4 Devices for emergency remote disconnection of the distribution board of the refrigerating plants working with group II refrigerant, shall simultaneously switch off the electrical drives of refrigerating compressors if they are fed directly from the main switchboard (see 20.2.1) and main lighting of the refrigerating machinery compartment and switch on the emergency ventilation, water screen and emergency lighting.

Additionally, near the devices for emergency remote disconnection of the refrigerating plants at locations referred to in 20.2.3.1 and 20.2.3.2, devices shall be provided

for remote starting of emergency ventilation, water screen and emergency lighting in any sequence without disconnection of the refrigerating plant distribution board.

20.2.4 The devices for the remote disconnection shall be so arranged, that there is no possibility of their unintentional activation.

20.2.5 Electrical heating appliances for hatches and doors of refrigerated spaces and freezing chambers are recommended to be supplied at safety voltage.

20.3 VENTILATION

20.3.1 When the refrigerants of group II are used, the suction fan electrical motors of the emergency ventilation in the refrigerating machinery rooms, installed in the suction ducts, shall be of safe type.

20.3.2 The electrical motors of fans located in the stream of air coming from the refrigerated cargo spaces, shall have a degree of mechanical protection not below IP55.

20.4 LIGHTING

When the refrigerants of group II are used, safe-type reserve lighting fixtures shall be installed in the refrigerating machinery room in addition to the main lighting fixtures.

The reserve lighting fixtures shall be supplied separately from the electrical equipment and main lighting fixtures installed in the refrigerating machinery room.

21 SPARE PARTS

21.1 GENERAL REQUIREMENTS

21.1.1 Each ship is recommended to have a store of spare parts in an amount specified in the present Section. For ships of the restricted area of navigation, the amount of spare parts may be reduced on agreement with the *Register*.

21.1.2 Type and the amount of spare parts for electrical propulsion plant and electrical slip couplings are subject to special consideration of the *Register* in each particular case.

21.1.3 Spare parts shall be ready for use without additional processing or adjustment

21.1.4 Spare parts shall comply with the requirements of the present Rules and shall be subjected to testing after their completion.

21.1.5 Spare parts shall be stowed and secured in accessible places, duly marked and reliably protected against environmental effects.

21.1.6 Each ship shall be provided with a set of special tools and accessories required for dismantling and assembling of electrical equipment under service conditions.

Each ship shall be provided with necessary materials for maintenance of accumulator batteries (distilled water, acid, alkali), cables and wires, bulbs, fluorescent lamps and their fittings, terminals, fuse links of all sizes for fuses, insulating materials as well as such materials as may be required for eliminating faults in electrical equipment.

21.1.7 Spare parts are not compulsory for the electrical drives of auxiliary engines, if they are provided in duplicate and if the power of one engine is sufficient under normal service conditions.

21.2 THE QUANTITY OF SPARE PARTS

The review of recommended spare parts is in Table 21.2.

Table 21.2

No.	Equipment	Spare parts	Quality of spare parts	Remarks
1	Generators and exciters	Brush holders	1 set	For 3 generators and 3 exciters of the same type
			1 pc	
		Bearings	1 set	
2	Static exciters	Power thyristors and diodes	1 pc of each type	For 3 exciters one spare exciter is recommended instead of spare parts
		Resistors, condensers power circuit inductances		
3	Electrical motors	Brush holders	1 pc	For 6 motors of the same type
		Bearings	1 set	
4	Steering gear	Brush holders	1 set	For each motor
			1 pc	
		Bearings	1 set	
		Armature with shaft and half of coupling	1 pc	For d. c. steering with one motor
		For d. c. steering gear	1 set	
Complete electrical motor	1 pc	For a. c. steering with one motor		
5	Belt drives	V-belts	1 set	
6	Switchboards, distribution boards, control consoles, etc.	Switch and circuit breakers up to 63 A		Up to 5 pcs of the same type
		Circuit breakers over 63 A	Contacts subject to wear	1 set
			Voltage coil	1 pc
			Are chute	1 pc
Fuses	2 pc			
7	Starting and control apparatuses and contactors	Contacts subject to wear	1 set	Of each type per 6 identical devices
		Voltage coil	1 pc	
8	Emergency lighting	Lamps	1 set	If lighting supply voltage differs from voltage on ship's mains
9	Navigation lanterns	Incandescent lamps	1 set	See COLREG 1972.
10	Navigation lights distribution board	Relay	2 pc	If required by execution
		Pilot lamps	1 set	

No.	Equipment	Spare parts	Quantity of spare parts	Remarks
11	Portable measuring instruments	Insulation resistance measuring instrument	1 pc	A multi-purpose multi-range instrument is recommended
		Ammeter	1 pc	
		Voltmeter	1 pc	
		Ohmmeter	1 pc	
12	Fans for cooled spaces of classed refrigerating plants	Rotor	1 pc	Per 6 d.c. motors of the same type, where no spare motors are available
		Set of coil	1 set	
		Stator	1 pc	Per 6 a.c. motors if the same type where no spare motors are available