

RULES FOR THE CLASSIFICATION OF SHIPS

Part 17 – FIRE PROTECTION
July 2024

CROATIAN REGISTER OF SHIPPING

Hrvatska (Croatia) • 21000 Split • Marasovićeve 67 • P.O.B. 187
Tel.: (...) 385 (0)21 40 81 11
Fax.: (...) 385 (0)21 35 81 59
E-mail: tech.coord@crs.hr
web site: www.crs.hr

By the decision of the General Committee to the Croatian Register of Shipping,

RULES FOR THE CLASSIFICATION OF SHIPS
Part 17 – FIRE PROTECTION

have been adopted on 21st June 2024 and shall enter into force on 1st July 2024

GENERAL TERMS AND CONDITIONS

(March 2022)

Article 1 GENERAL

1.1 CROATIAN REGISTER OF SHIPPING (hereinafter: the *Register*) shall at all times remain an independent contractor and neither the *Register* nor any of its officers, surveyors, auditors, inspectors, agents, appointers, officers or managers shall act as an employee, servant or agent of any other party in the performance of the Services rendered by the *Register*.

1.2 The *Register* acts as a service provider. The Services provided by the *Register* cannot be construed as a commitment by the *Register* to achieve any result or as a warranty.

1.3 The provision of Services is subject to these General Terms and Conditions. No other terms and conditions shall apply, either expressly or by implication, unless expressly agreed in writing between the Parties.

1.4 These General Terms and Conditions shall be incorporated into, or referred to in any Contract and shall prevail over and exclude any other terms and conditions that the Client may wish to impose.

Any amendments to and/or deviations from these General Terms and Conditions, as well as any additional terms and conditions of the Client, shall be binding or valid only if set forth in writing and duly signed by the authorised representatives of both Parties.

1.5 The invalidity of one or more provisions of these General Terms and Conditions shall not affect the remaining provisions.

1.6 The Client acknowledges that the latest version of these General terms and Conditions and the latest version of applicable Rules apply to the Services provided by the *Register*.

1.7 Definitions in these General Terms and Conditions take precedence over other definitions that may appear in other documents issued by the *Register*.

1.8 The Client should at all times be aware of the provisions of these General Terms and Conditions, as they may be further amended, with their latest up to date version available on the web site of the *Register*.

Article 2 DEFINITIONS

2.1 **Certificate** means either a class certificate or statutory certificate, statement, attestation, statement of compliance, and a report following the Services provided by the *Register*.

2.2 **Certification** means the activity of certification in application of international and national standards and international industry practice provided by the *Register*.

Certification is an appraisal given by the *Register* to the Client and cannot be construed as an implied or express warranty of safety, fitness for purpose, seaworthiness of the vessel or its value for sale, insurance or chartering.

The purpose of Certification is to provide classification and statutory services and assistance to the maritime industry, Flag State Administrations, and regulatory authorities relating to maritime safety and pollution prevention.

2.3 **Classification** includes all activities and Services provided by the *Register* in accordance with the Rules. Classification may or may not be accompanied by the issuance of a Certificate of class with reference to the Rules.

Certificate of class is valid only if issued by the *Register*.

However, Certificate of class should not be construed as a guarantee of the safety, fitness for purpose or seaworthiness of the vessel. It is merely an attestation that the vessel complies with the Rules developed and published by the *Register*.

In addition, the *Register* is not a guarantee of the safety of life or property at sea or the seaworthiness of a vessel because, although the classification of a vessel is based on the assumption that the vessel will be properly loaded, operated, and maintained by competent and qualified personnel, the *Register* has no control over how a vessel is operated and maintained between the periodic surveys it conducts.

2.4 **Statutory certification** means certification made by the *Register* on behalf of the Flag State Administrations when and to the extent that the *Register* has been authorised to do so by the respective Flag State.

Statutory certification and services include the assessment of vessels registered by the Flag State and/or ship management companies to determine whether such ships/companies comply with the applicable requirements of international conventions, codes and national legislation, and the issuance of, or assistance in the issuance of, the appropriate certificates and documents.

Statutory certification includes, but is not limited to, certification, survey, and issuance of statutory certificates on behalf of the Flag State.

In cases where the *Register* acts on behalf of Flag State Administrations, the *Register* shall follow guidance issued by IMO (Resolutions, Circulars, etc.) or by IACS through Unified Interpretations (UI), unless otherwise directed by the Flag State.

2.5 **Client** means the shipowner, company, shipyard and/or party requesting Services or taking ownership of a classed vessel. In cases where shipowners have authorized another party to operate the vessel on their behalf, that party shall be considered as the company.

In addition to the above the Client means the person and/or entity that has requested Services from the *Register* and that has entered into a Contract or an agreement for Services with the *Register*.

2.6 **Parties** means the *Register* and Client together.

2.7 **Party** means the *Register* or the Client.

2.8 **Contract** means the contract in the form of a written agreement between the Client and the *Register* requesting Services, including these General Terms and Conditions and the Rules.

The provisions related to the Contract in these General Terms and Conditions shall apply even if there is no written agreement between the Client and the *Register*.

The Client may request the *Register* in writing to make a change to the contracted Services. However, the *Register* shall not be obligated to accept or execute any such change until a written agreement has been signed with the Client regarding the compensation and the possible impact of the change on the schedule as an addendum to the originally contracted Services.

2.9 **Services** shall mean the services specified in 2.2, 2.3 and 2.4, but also other services related to certification, classification and statutory certification, such as, but not limited to: ISM Code certification, ISPS Code, MLC 2006 certification, fuel oil consumption reporting, IHM certification, approval of manufacturers and service providers, certification of materials and products, training activities, conformity assessment, and any other relevant activities such as third party inspections, testing, shore and shipboard trials.

The Services provided by the *Register* are performed on a random basis and in no case include a full inspection of all items.

The *Register* shall provide the Services in accordance with related Contract(s), the provisions of these General Terms and Conditions, Rules, the international and national standards, the international conventions, the EU Regulations, the Flag State requirements and the industry practices applicable to the particular Service and always assuming that the Client is aware of these standards and the industry practices.

When providing Services, the *Register* does not guarantee the accuracy of the information or advice provided.

In providing Services, the *Register* does not assess compliance with standards other than the Rules, international and national standards, international conventions, EU regulations, Flag State requirements and industry practice, to the extent agreed in writing or specified in the Contract.

2.10 The *Register* means the Croatian Register of Shipping, an entity organized and existing under Croatian law, which, according to the Law on the Croatian Register of Shipping (Official Gazette No. 1996/81, 2013/76 and 2020/62) and the Charter of the *Register*, is an independent, not-for-profit, but public welfare oriented, public foundation that performs tasks:

- classification of sea-going ships,
- statutory certification of sea-going ships on behalf of the Flag State Administrations,
- classification of inland navigation vessels,
- statutory certification of inland navigation vessels,
- statutory certification of recreational crafts,
- certification of materials and products,
- conformity assessment of recreational crafts,
- conformity assessment of marine equipment,
- conformity assessment of pressure vessels,
- certification/registration of quality management systems.

2.11 **Vessel** means a ship, vessel, unit or offshore structure of any kind, whether or not connected to the shore or sea/river bed, located at sea or in inland waters and intended for transportation or special operations on the water, as decided by the *Register*.

2.12 **Rules** means the Rules for the classification, guidelines, instructions, or other documented evidence of the *Register* related to the Services provided.

The competent interpretation of the requirements specified in the Rules or other regulations published by the *Register* shall be the exclusive responsibility of the *Register's* Head Office, notwithstanding any possible different interpretations by other parties.

In cases where the Rules do not contain detailed requirements, the specific approval by the *Register* shall be based on the principles of the Rules and shall ensure a safety standard equivalent to that of the Rules.

Article 3 RESPONSIBILITIES

3.1 It is the Client's responsibility to ensure that all surveys required for vessel's class maintenance are conducted in a timely manner and in accordance with the Rules.

3.2 The *Register* may suspend or withdraw the vessel's existing Certificate of class in the event of serious deficiencies and replace it with a new Certificate of class with a shortened period of validity during which the deficiencies are to be rectified.

In addition, the *Register* shall suspend or withdraw a vessel's Certificate of class if the deficiencies are of such a magnitude as to endanger the class of the vessel, its safety and integrity, the safety of the crew, passengers, or the marine environment, and shall require that the vessel is to be inspected at the first port of call where the necessary repairs are to be carried out.

3.3 The Client should inform the *Register*:

- (i) in the event of a change in the intended use of a vessel, a conversion and alteration of the hull, machinery installations and other equipment affecting the Class of the vessel assigned by the *Register*. Conversions and alterations must be made under the supervision of the *Register* and must comply with the requirements of the Rules and/or additional requirements of the *Register*,
- (ii) in cases where the vessel has been damaged to such an extent that the Class of the vessel is likely to be affected and the safety and integrity of the vessel is likely to be compromised. In such cases, the vessel must be surveyed at the first port of call or as further directed by the *Register*. The survey shall be to the extent deemed necessary by the *Register*, by taking into account the extent of the damage.
- (iii) in cases where class-related deficiencies and/or defects are found as a result of a Flag State inspection or Port State Control. Should the Client fail to notify the *Register* of the detention of the vessel by Port State Authorities due to class related deficiencies, the *Register* reserves the right to suspend or withdraw the Certificate of class.

3.4 The *Register* shall have full control over Certificates issued and may suspend or withdraw a Certificate at any time in its sole discretion if the Client fails to comply with the following requirements set forth in the *Rules for the Classification of Ships, Part 1 - General Requirements, Chapter 1 - General Information*, as applicable:

- (i) para. 5.3 - *Maintenance of the validity of Certificate of Class*,
- (ii) para. 5.4 - *Period of Validity*,
- (iii) para. 5.5 - *Extension of the Period of Validity*,
- (iv) para. 5.6 - *Suspension and Reinstatement of Class in the Case of Overdue Surveys*, and
- (v) para. 5.7 - *Withdrawal of Class*.

3.5 The *Register* may suspend or withdraw a Certificate at any time in its sole discretion if the Client fails to comply with the following requirements set forth in the *Rules for the Classification of Inland Navigation Vessels, Part 1 - Classification and Surveys, Chapter 1 - Principles of Classification*, as applicable:

- (i) para. 2.8 - *Maintenance of the Validity of the Certificate of Class*,
- (ii) para. 2.9 - *Extension of validity of the Certificate of Class*, and following requirements set forth in the *Rules for the Classification of Inland Navigation Vessels, Part 1 - Classification and Surveys, Chapter II - Classification*, as applicable:
- (iii) para. 2.1 - *Suspension of Class*,
- (iv) para. 2.2 - *Withdrawal of Class*.

3.6 In addition to clauses 3.2, 3.4 and 3.5 of this Article, the *Register* reserves the right to terminate the Services and related Contract in the event of a breach of the provisions of these General Terms and Conditions.

3.7 If the Client fails to provide the *Register* with the required access or information at the agreed times or fails to prepare for the Service in a timely manner, the *Register* may suspend the provision of the Service until it receives the Client's instructions for access and/or the required information.

The *Register* shall not be liable for the consequences of such suspension, and the Client shall be responsible for the *Register's* additional fees and other unnecessary costs and expenses incurred by the *Register*.

3.8 The Client is obliged to perform timely payments of the invoices for provided Services. However, the *Register* may retain or withhold any Service or Certificate to the Client in the case of outstanding payments, whether mutually related or not, arising out of the entire business relationship with the Client.

Article 4

HEALTH, SAFETY AND ENVIRONMENT

4.1 Both the *Register* and the Client shall apply reasonable standards to promote safety, health, and environmental protection and to provide a safe working environment for their personnel.

4.2 The Client shall provide the *Register* with all access and information necessary for the safe and efficient performance of the requested Services as required by the Rules.

4.3 During the survey, personnel of the *Register* should have secure access to all work that directly or indirectly affects the Service.

4.4 The *Register* has the right to refuse to conduct an activity or visit an area or site if the *Register* in its sole discretion, believes that relevant risks are unacceptable or are not adequately addressed, contained, or otherwise mitigated.

Such a decision shall suspend the obligations of both Parties under the Contract without incurring any liability or penalty until the Parties agree on how to proceed.

Article 5

THIRD PARTIES AND SUBCONTRACTORS

5.1 Each specific Contract, including any Certificates issued, relates specifically to the Client, and no rights, obligations, interests, claims, benefits or Certificates issued shall extend to any third party without the prior written consent of the *Register*.

5.2 The Client shall not be entitled to grant any right to use the Certificates to any third party without the prior written consent of the *Register*.

5.3 The Client shall not without *Register's* consent, cede, assign, transfer, subcontract or deal in any manner with all or any of its rights or obligations under any Service and related Contract.

5.4 With regard to third party rights to access information and Certificates under confidentiality clause reference is to be made to Article 9.

Article 6

TAXES

6.1 Each Party shall be responsible for and shall bear all taxes, duties or similar governmental charges levied or imposed on any activity of that Party.

6.2 Prices, fees, rates, or remuneration are exclusive of any form of sales tax, value added tax, administrative fees and services tax and/or other similar taxes, including any surcharges. If any such indirect tax is or becomes applicable to the Services provided under the Contract, the Client shall be responsible for the payment of such indirect taxes.

Article 7

PAYMENT OF INVOICES

7.1 The provision of Services by the *Register*, whether complete or not, shall include payment of fees thirty (30) days after issuance of the invoice for the portion of the Services performed.

7.2 In the event that the Client fails to meet the requirements for payment in accordance with the instalments and terms of payment contained herein, the *Register* reserves the right to charge the Client with the interest rate in accordance with the applicable laws of the Republic of Croatia.

7.3 If the Client disputes an invoice or part of an invoice, the Client shall notify *Register* thereof in writing without undue delay. If no notification is received by the due date, Client shall be deemed to have accepted the invoice in full. If only part of an invoice is disputed, the undisputed amount must be paid by the due date.

Consequently, no disputes arising between the *Register* and the Client shall interfere with prompt payment of invoices by the Client. Any rights of lien or retention in favour of the Client or otherwise, are hereby excluded.

7.4 In the event of cancellation of all or part of the Services prior to their final completion, the Client shall pay all costs incurred by the *Register* on pro-rata basis for the portion of the Services provided to date. In such event, the *Register* will not claim the Client for loss of profit or reduced income. All reasonable costs directly attributable to the early termination and all amounts due to the *Register* at that time shall become immediately due and payable.

7.5 In the event of termination of the Service and related Contract, the *Register* shall be entitled to retain any payments, deposits or prepayments of fees made by the Client prior to the date of termination up to the amount to which the *Register* is entitled.

Article 8

TERMINATION

8.1 The Parties shall have the right to terminate the Services and the related Contract(s) by written notice to the other Party, and without prejudice to Article 7, in the following cases:

- (i) if the other Party commits a material breach of these General Terms and Conditions and/or the Contract and fails to rectify such breach in accordance with clause 8.4 of this Article,
- (ii) if the other Party becomes insolvent, is unable to pay its debts as they become due, or becomes subject to bankruptcy proceedings, administration, receivership, dissolution, liquidation, winding up or otherwise ceases to carry on its business; or
- (iii) for convenience, after giving the other Party thirty (30) days' prior written notice of termination.

8.2 The Classification issued for the relevant vessel and the Certificates previously issued shall remain valid until the effective date of termination or, in the event of such termination, immediately, subject to compliance with Article 3 and Article 7.

8.3 If, in the reasonable opinion of the *Register*, the Client breaches or is suspected of breaching Article 14 or Article 15, the *Register* shall have the right to terminate the Service and related Contract with immediate effect.

8.4 Notwithstanding the provisions of clause 8.1 of this Article, the Party intending to terminate Services for non-compliance or breach of the provisions of these General Terms and Conditions shall notify the other Party of the non-compliance or violation of the provisions of these General Terms and Conditions and set a reasonable deadline of 15 (fifteen) days for the other Party to remedy the breaches of the provisions of these General Terms and Conditions.

If the Party fails to remedy the breaches of the provisions of these General Terms and Conditions within the aforementioned period, the other Party shall have the right to terminate Services without further notice.

8.5 Termination of the Service and related Contract pursuant to the provisions of these General Terms and Conditions shall not give either Party the right to claim any additional compensation, indemnity or reimbursement from the other Party as a result of such termination, but such termination shall not affect any rights or remedies available to a Party at the time the termination becomes effective or any obligations or liabilities incurred by a Party.

Article 9 CONFIDENTIALITY

9.1 The Parties agree to keep confidential all facts, data, information, etc. related to the other Party's business that they have learned in the course of providing Services. Such information and data shall not be disclosed by the Parties to any third party and shall not be used or misused to the detriment of the other Party.

9.2 The *Register* will keep confidential any data, plans or other technical information received from the Client and will not disclose it to any third party outside the *Register*, unless authorised by the Client. This obligation shall continue to apply after termination of the Services. This obligation shall not apply to any data, plans or other technical information that was in the possession of the *Register* prior to being disclosed to the *Register* by or on behalf of the Client, or that becomes publicly available through no fault of the *Register*, or is otherwise provided to the *Register* by an independent source that is under no obligation of confidentiality to the *Register*.

9.3 Certificates issued by the *Register* to the Client as a result of the Services provided shall not be covered by the confidentiality Article.

Notwithstanding the foregoing, the Client shall be entitled to disclose any data to its affiliates involved in the transactions related to the Services or the Client's core activities.

9.4 Notwithstanding clause 9.1 and clause 9.2 of this Article, the *Register* shall have the right to disclose the Confidential Information to the following parties if required by regulations of:

- (i) authorised representatives of the Flag State Administration,
- (ii) authorised audit teams (i.e., accreditation body or EC auditors),
- (iii) the International Association of Classification Societies (IACS),
- (iv) a court of competent jurisdiction, government agency, or other relevant public authority, in accordance with applicable law, court order, or other public regulation.

9.5 The Client acknowledges that the *Register* is required to provide access to information to the EU Commission or any person acting on its behalf in accordance with applicable EU requirements and that the Client shall give the EU Commission with unrestricted access to the vessels for the purpose of inspection.

9.6 The obligations in this Article shall survive the conclusion of the Service or the termination of related Contract and shall continue for as long as the relevant information remains confidential.

Article 10 INTELLECTUAL PROPERTY

10.1 Each Party shall be the sole owner of all rights to its Intellectual Property created before or after the effective date of these General Terms and Conditions, whether or not associated with any Contract between the Parties.

10.2 The Intellectual Property developed by the *Register* for the provision of the Services, including but not limited to drawings, calculations and reports, shall remain the exclusive property of the *Register*.

Article 11 PROFESSIONAL ETHICS

11.1 Each of the Parties warrants that, with respect to the matters contemplated herein, neither it nor its affiliates has made or will make, directly or indirectly, any offer, payment, gift or authorization of money to any government official or employee, political party, public official or candidate for the benefit or advantage thereof.

11.2 In providing the Services, the *Register* shall strictly adhere to the requirements of its Code of Ethics relating to business activities.

Article 12 FORCE MAJEURE

12.1 For the purposes of these General Terms and Conditions, the term "Force Majeure" includes any event that directly or indirectly prevents the Parties from fulfilling their obligations due to events beyond their control, such as: strikes, wars, riots, piracy, civil commotion, malicious damage, pandemic, compliance with laws or government orders, rules, regulations or directives, sanctions and embargoes, accidents, defects of plants or machinery, seizures, fires, floods, storms and the like.

12.2 If either Party is prevented or delayed from performing its obligations by Force Majeure, such Party shall promptly notify the other Party in writing of the circumstances of the Force Majeure and its influence and, after such notification, shall not be liable for performance of any obligations prevented by the influence of the Force Majeure during its duration. Upon termination of the influence of the Force Majeure, the same Party should proceed with the planned activities in order to fulfil its obligations.

12.3 If one of the Parties is prevented by Force Majeure in its activities and fulfilment of its obligations and this event lasts continuously for three (3) months, the other Party shall be entitled to terminate the Service and related Contract without liability.

12.4 Neither of the Parties shall be liable for non-compliance with these General Terms and Conditions due to Force Majeure. If one of the Parties is prevented from fulfilling its obligations under these General Terms and Conditions due to Force Majeure, it shall immediately notify the other Party in writing within a reasonable period of time, stating the reasons for the Force Majeure and providing relevant evidence, if any.

Article 13 INDEMNIFICATIONS

13.1 Each Party shall indemnify the other Party against all claims arising out of the performance of the Services in respect of bodily injury, illness or death of any of its employees or other representatives and in respect of loss of or damage to the Party's property.

This provision shall apply whether or not the damage is caused or contributed to by the negligence of the other Party. Both Parties are obliged to take out separate insurances for these liabilities.

13.2 The Client shall indemnify the *Register* from and against all claims arising from the Client's violation of the provisions of these General Terms and Conditions and from the misuse of the Certificates issued by the *Register*.

13.3 The Client shall indemnify the *Register* against any financial responsibility or amounts arising from non-payment, late payment or payment of withholding taxes to the non-relevant tax authority or any other relevant governmental body.

13.4 Each Party shall notify the other Party without undue delay as soon as it becomes aware of any incident that could give rise to a claim against the other Party in respect of the Service provided and related Contract.

Article 14 ANTI-CORRUPTION

14.1 Each Party agrees that in performing its obligations under any Service, it will ensure that its affiliates, employees and/or agents, subsidiaries, subcontractors, consultants, and any other persons providing Services will:

- (i) comply with all applicable anti-bribery and anti-corruption laws (collectively, Anti-Bribery Laws) and, in particular, do not, directly or indirectly, offer, promise, grant, authorise the payment of, or confer any financial or other benefit on any public or government official:
 - to a public or governmental official to obtain or retain business with the intent to influence such official in his or her capacity as an official, if such official is not permitted or required by written law to be influenced by the offer, promise or gift; or
 - to another person with the intent to induce or reward the improper performance of a function or activity or for any other illegal purpose,
- (ii) maintain adequate systems and procedures designed to prevent activities, practises, or conduct in connection with services that would constitute an offence under an anticorruption law; and
- (iii) take reasonable steps to prevent similar acts by customers, contractors, subcontractors, agents and other third parties, persons under its control or influence.

14.2 Any failure by a Party to comply with or ensure compliance with its obligations under this Article shall, notwithstanding anything to the contrary in these General Terms and Conditions, be deemed a breach of these General Terms and Conditions which shall entitle the other Party to suspend and/or terminate the Services by notice in writing with immediate effect without further liability to the other Party except for any liability which may have arisen prior to the date of termination or suspension (as the case may be).

14.3 If a Party elects to suspend the provision of Services under these General Terms and Conditions pursuant to this Article, it shall have the sole and absolute discretion to determine:

- (i) when it will resume performance (if at all); and
- (ii) extend the period for performance of its obligations under the Services in its sole discretion.

Article 15 SANCTIONS

15.1 Each Party shall conduct all activities in compliance with all laws, statutes, rules, economic and trade sanctions (including, but not limited to, U.S. sanctions and EU sanctions) and regulations applicable to such Party, including, but not limited to: child labour, forced labour, collective bargaining, discrimination, abuse, working hours and minimum wages, anti-bribery, anti-corruption, copyright and trademark protection, personal data protection.

15.2 Each Party hereby represents and warrants that it is not or will not be subject to any economic or trade sanctions ("Sanctions") imposed by the United States of America, the European Union, the United Kingdom, any EU Member State, or the United Nations with respect to any country and/or by any sanction giver with respect to any company/individual.

15.3 Each Party represents and warrants that it will strictly comply with all Sanctions.

15.4 Nothing in these General Terms and Conditions shall be construed as causing or obligating either Party to act or refrain from acting in a manner inconsistent with, punishable by, or prohibited by any Sanctions.

15.5 Neither Party shall be obligated to perform any obligation arising under these Terms and Conditions (including, without limitation, the obligation to):

- (i) perform, deliver, accept, sell, purchase, pay or receive any funds to, from or through any person or entity; or
- (ii) engage in any other action whatsoever,
if doing so violates or is inconsistent with sanctions and/or recommendations of international (intergovernmental) organisations to combat the financing of terrorism and other criminal activities and/or money laundering or exposes such Party to investigation or penalties.

15.6 In the event that a Party breaches any Sanctions or the Party's Business and/or Transactions arising out of or in connection with these General Terms and Conditions breach any Sanctions or otherwise violate the recommendations of one or more international (intergovernmental) organisations for combating the financing of terrorism and other criminal activities and/or money laundering, the other Party shall be entitled to terminate these General Terms and Conditions by written notice with immediate effect without incurring any liability to the other Party, except for liabilities (if any) incurred prior to the date of termination.

Article 16 LIABILITY

16.1 The *Register* is not, and cannot be considered as, an underwriter, consulting engineer, naval architect, shipbuilder, shipowner, or ship management company, nor can it assume the obligations and responsibilities associated with such functions, although the *Register's* experience may enable it to respond to inquiries about matters not covered by its Rules, policies, instructions, or other documented evidence.

16.2 The practices and procedures of the *Register* shall be selected by the *Register* in its sole and absolute discretion based on its experience and knowledge and in accordance with generally accepted professional standards in the relevant field of classification societies.

16.3 Nothing herein contained shall release any designer, naval architect or engineer, shipbuilder or manufacturer, shipyard, vendor, supplier, contractor or subcontractor, repairer or owner, from any information, report, certificate or similar document issued in connection with the provision of Services by the *Register*, operator, manager or other person or entity from any express or implied warranty or other contractual obligation or responsibility, or from any negligent act, error or omission of any kind whatsoever, nor shall they create any right, claim or benefit for any third party.

16.4 The *Register* shall exercise due care in the selection or appointment of its surveyors and all other employees whose presence and work is necessary for the provision of the Services.

16.5 If any person or entity using the Services of the *Register* suffers any loss, damage or expense that is or is shown to have been caused by a negligent act, omission or error of the *Register's* officers, surveyors, auditors, inspectors, agents, appointers, officers or managers, or those purporting to act in the name of and on behalf of the *Register*, or a negligent inaccuracy, advice, report or evidence given by or in the name of or/and on behalf of the *Register*, then the liability of the *Register* is limited in respect of any direct or indirect claim shall be limited to an amount not exceeding five times the fee charged or to be charged by the *Register* for the relevant Service.

16.6 Any liability for consequential damages is expressly excluded.

For purposes of this clause, consequential damages include, without limitation:

- (i) indirect or consequential damages,

- (ii) loss and/or delay of production, loss of products, loss of use, loss of bargain, loss of revenue, loss of profit or anticipated profit, loss of business and business interruption, in each case directly or indirectly.

16.7 The Parties are not entitled to assign the performance of obligations under these General Terms and Conditions or parts thereof to third parties without the prior written consent of the other Party.

16.8 If during the term of the Contract, there is a transfer of function due to change of status (merger, acquisition, division, etc.), all obligations and rights under these General Terms and Conditions and associated Contract will be transferred to the legal successor of the Party concerned.

Article 17 GOVERNING LAW AND RESOLVING OF DISPUTES

17.1 These General Terms and Conditions and any dispute or claim between the Parties arising from or in connection with it, or the Services provided hereunder, will be governed and interpreted in accordance with the English law.

17.2 The Parties shall use their reasonable efforts to resolve any claim or dispute arising in relation to rendered Service by negotiations within a reasonable time.

17.3 Should the Parties fail to resolve any claim or dispute by negotiations, the dispute shall be exclusively subject to the jurisdiction of the Permanent Arbitration Court with the Croatian Chamber of Economy in Zagreb, Republic of Croatia.

17.4 The Parties agree to keep the any arbitration proceedings confidential.

17.5 Notwithstanding the above, any claim not presented within three (3) months of the completion of the particular Services, or within three (3) months of the date when the events which are relied on were first discovered by the Client, shall be deemed waived and absolutely time barred.

17.6 Any objections against the line adopted by any of the *Register's* servants in fulfilling their duties or against the conclusions reached are to be raised to the *Register* by the Party as soon as possible.

If the Party is not satisfied with the final conclusions and interpretations by the *Register* the arbitration lays upon the Commission for appeal for Classification and Statutory certification of ships, which is to be formed according to the Regulation 39 of the Charter of the *Register*.

REVIEW OF AMENDMENTS IN RELATION TO PREVIOUS EDITION OF THE RULES

RULES FOR THE CLASSIFICATION OF SHIPS

Part 17 – FIRE PROTECTION

All major changes in respect to the Rules for the classification of ships, Part 17 – Fire protection, edition January 2022, as last amended by Amendments No. 4, edition January 2024, throughout the text are shaded (if any).

Items not being indicated as corrected have not been changed.

The grammar and print errors, have been corrected throughout the Rules for the classification of ships and are not subject to above indication of changes.

This Part of the Rules for the classification of ships includes the requirements of the following international Organisations:

International Maritime Organization (IMO)

Conventions: International Convention for the Safety of Life at Sea, 1974 (SOLAS 74) and all subsequent and applicable amendments adopted up to MSC 106
Protocol of 1988 relating to the International Convention for the Safety of Life at Sea, 1974, as amended (SOLAS PROT 1988)

Resolutions: A.123(V), A.567(14), A.654(16), A.752(18), A.756(18), A.800(19), A.951(23), A.952(23), A.1021(26) and A.1116(30); MSC.62(67)/Rev.1; MSC.98(73), MSC.206(81), MSC.217(82), MSC.256(84), MSC.265(84), MSC.266(84), MSC.269(85), MSC.284(86), MSC.291(87), MSC.292(87), MSC.307(88), MSC.308(88), MSC.311(88), MSC.327(90), MSC.338(91), MSC.339(91), MSC.365(93), MSC.367(93), MSC.380(94), MSC.392(95), MSC.403(96), MSC.404(96), MSC.408(96), MSC.409(97), MSC.410(97), MSC.421(98), MSC.437(99), MSC.457(101) and MSC.484(103)

Circulars: MSC/Circ.353, MSC/Circ.387, MSC/Circ.451, MSC/Circ.474, MSC/Circ.485, MSC/Circ.553, MSC/Circ.606, MSC/Circ.608 Rev.1, MSC/Circ.670, MSC/Circ.677, MSC/Circ.730, MSC/Circ.731, MSC/Circ.777, MSC/Circ.798, MSC/Circ.808, MSC/Circ.848, MSC/Circ.849, MSC/Circ.858, MSC/Circ.910, MSC/Circ.917, MSC/Circ.917/Corr.1, MSC/Circ.1002, MSC/Circ.1003, MSC/Circ.1005, MSC/Circ.1009, MSC/Circ.1035, MSC/Circ.1036, MSC/Circ.1037, MSC/Circ.1050, MSC/Circ.1081, MSC/Circ.1082, MSC/Circ.1084, MSC/Circ.1085, MSC/Circ.1086, MSC/Circ.1087, MSC/Circ.1120, MSC/Circ.1129, MSC/Circ.1142, MSC/Circ.1165, MSC/Circ.1167 and MSC/Circ.1168;
MSC.1/Circ.1002/Corr.1, MSC.1/Circ.1002/Corr.2, MSC.1/Circ.1120/Corr.1, MSC.1/Circ.1203, MSC.1/Circ.1237, MSC.1/Circ.1240, MSC.1/Circ.1242, MSC.1/Circ.1266, MSC.1/Circ.1267, MSC.1/Circ.1268, MSC.1/Circ.1269, MSC.1/Circ.1270, MSC.1/Circ.1270/Corr.1, MSC.1/Circ.1275, MSC.1/Circ.1275/Corr.1, MSC.1/Circ.1276/Rev.1, MSC.1/Circ.1312, MSC.1/Circ.1312/Corr.1, MSC.1/Circ.1314, MSC.1/Circ.1316, MSC.1/Circ.1317, MSC.1/Circ.1319, MSC.1/Circ.1320, MSC.1/Circ.1322, MSC.1/Circ.1324, MSC.1/Circ.1368, MSC.1/Circ.1369/Add.1, MSC.1/Circ.1370, MSC.1/Circ.1384, MSC.1/Circ.1385, MSC.1/Circ.1386, MSC.1/Circ.1387/Corr.1, MSC.1/Circ.1388, MSC.1/Circ.1395/Rev.6, MSC.1/Circ.1422, MSC.1/Circ.1430/Rev.3, MSC.1/Circ.1431, MSC.1/Circ.1432, MSC.1/Circ.1433, MSC.1/Circ.1434, MSC.1/Circ.1435, MSC.1/Circ.1436, MSC.1/Circ.1437, MSC.1/Circ.1456, MSC.1/Circ.1458, MSC.1/Circ.1459, MSC.1/Circ.1471, MSC.1/Circ.1472, MSC.1/Circ.1480, MSC.1/Circ.1487, MSC.1/Circ.1488, MSC.1/Circ.1491, MSC.1/Circ.1492, MSC.1/Circ.1499, MSC.1/Circ.1501, MSC.1/Circ.1505, MSC.1/Circ.1510, MSC.1/Circ.1511, MSC.1/Circ.1514, MSC.1/Circ.1515, MSC.1/Circ.1516, MSC.1/Circ.1527, MSC.1/Circ.1528, MSC.1/Circ.1533, MSC.1/Circ.1539/Rev.1, MSC.1/Circ.1550, MSC.1/Circ.1552, MSC.1/Circ.1554, MSC.1/Circ.1555, MSC.1/Circ.1556, MSC.1/Circ.1573, MSC.1/Circ.1581, MSC.1/Circ.1582/Rev.1, MSC.1/Circ.1616, MSC.1/Circ.1634; MSC.1/Circ.1655; BLG.1/Circ.23

International Association of Classification Societies (IACS)

Unified requirements (UR):

F1(2002), F2(2012), F3(1971), F5(1973), F6(1996), F7 (rev. 3, June 2020; corr. 1 Nov. 2020), F13(1977), F16(2000), F20(2015), F21(1974), F26(2004), F27(1978), F29(2005), F32(1976), F33(1981), F35(2005), F41(1993), F43(2002), F44(2010); F45(2021) and F46 (2021)

Unified Interpretations (UI):

SC16(2006), SC17(2020), SC25(2005), SC30(2023), SC35(2013), SC39(2005), SC41(2005), SC42(2021), SC43(2021), SC45(2005), SC46(2005), SC48(2005), SC49(2021), SC52(2005), SC54(2005), SC55(2005), SC57(2021), SC58(2005), SC62(2020), SC64(2021), SC70(2023), SC73(2005), SC75(2005), SC79(2021), SC84(2005), SC85(2021), SC87(2021), SC89(2018), SC90(2005), SC91(2020), SC92(2005), SC97(2005), SC98(2005), SC99(2014), SC100(2014), SC101(2005), SC102(2005), SC103(2005), SC106(2005), SC107(2005), SC108(2005), SC109(2005), SC110(2005), SC111(2005), SC114(2005), SC118(2015), SC119(2005), SC120(2023), SC121(2023), SC125(2020), SC126(2021), SC127(2023), SC129(2005), SC130(2005), SC132(2013), SC140(2011), SC146(2021), SC147(2021), SC148(2015), SC149(2012), SC150(2005), SC158(2005), SC159(2021), SC160(2005), SC162(2005), SC163(2009), SC164(2005), SC166(2005), SC167(2021), SC168(2005), SC169(2021), SC172(2005), SC173(2003), SC174(2006), SC175(2003), SC176(2004), SC178(2011), SC188(2015), SC192(2004), SC196(2005), SC197(2021), SC198(2022), SC199(2005), SC200(2022), SC201(2022), SC204(2022), SC205(2006), SC211(2007),

SC214(2006), SC217(2022), SC218(2022), SC219(2022), SC239(2010), SC240(2011), SC241(2010), SC243(2012), SC245(2023), SC247(2011), SC250(2022), SC252(2011), SC253(2016), SC260(2015), SC262(2015), SC264(2023), SC268(2014), SC269(2016), SC270(2015), SC271(2015), SC272(2015), SC273(2015), SC275(2016), SC276(2016), SC277(2016), SC278(2016), SC282(2016), SC284(2018), SC285(2018), SC286(2018), SC287(2018), SC288(2018), SC291(2018), SC294(2018) and **SC300(2023)**;

FTP3(2021), FTP4(2022), FTP5(2022) and FTP6(2015)

Recommendations (Rec.):

No.123 (2012), No.131(2023) and No.135(2014)

Contents:

Page

| | | |
|----------|---|-----------|
| 1 | GENERAL..... | 1 |
| 1.1 | APPLICATION | 1 |
| 1.2 | SCOPE OF SURVEY AND TECHNICAL DOCUMENTATION | 3 |
| 2 | FIRE SAFETY OBJECTIVES AND FUNCTIONAL REQUIREMENTS | 5 |
| 2.1 | FIRE SAFETY OBJECTIVES | 5 |
| 2.2 | FUNCTIONAL REQUIREMENTS | 5 |
| 2.3 | ACHIEVEMENT OF THE FIRE SAFETY OBJECTIVES | 5 |
| 3 | DEFINITIONS AND EXPLANATIONS..... | 6 |
| 3.1 | DEFINITIONS | 6 |
| 4 | PROBABILITY OF IGNITION..... | 11 |
| 4.1 | GENERAL REQUIREMENTS | 11 |
| 4.2 | ARRANGEMENTS FOR OIL FUEL, LUBRICATION OIL AND OTHER FLAMMABLE OILS | 11 |
| 4.3 | ARRANGEMENTS FOR GASEOUS FUEL FOR DOMESTIC PURPOSES | 15 |
| 4.4 | MISCELLANEOUS ITEMS OF IGNITION SOURCES AND IGNITABILITY..... | 16 |
| 4.5 | CARGO AREAS OF TANKERS | 16 |
| 4.6 | HOT WORK, GAS WELDING EQUIPMENT AND GAS CYLINDERS ROOMS | 24 |
| 5 | FIRE GROWTH POTENTIAL..... | 25 |
| 5.1 | GENERAL REQUIREMENTS | 25 |
| 5.2 | CONTROL OF AIR SUPPLY AND FLAMMABLE LIQUID TO THE SPACE..... | 25 |
| 5.3 | FIRE PROTECTION MATERIALS | 25 |
| 5.4 | STORE-ROOMS FOR FLAMMABLE LIQUIDS AND READILY COMBUSTIBLE MATERIALS..... | 27 |
| 6 | SMOKE GENERATION POTENTIAL AND TOXICITY | 28 |
| 6.1 | GENERAL REQUIREMENTS | 28 |
| 6.2 | PAINTS, VARNISHES AND OTHER FINISHES | 28 |
| 6.3 | PRIMARY DECK COVERINGS | 28 |
| 7 | FIRE DETECTION AND ALARM | 29 |
| 7.1 | PURPOSE..... | 29 |
| 7.2 | GENERAL REQUIREMENTS | 29 |
| 7.3 | INITIAL AND PERIODICAL TESTS | 29 |
| 7.4 | PROTECTION OF MACHINERY SPACES | 29 |
| 7.5 | PROTECTION OF ACCOMMODATION AND SERVICE SPACES AND CONTROL STATIONS..... | 29 |
| 7.6 | PROTECTION OF CARGO SPACES IN PASSENGER SHIPS..... | 30 |
| 7.7 | MANUALLY OPERATED CALL POINTS..... | 30 |
| 7.8 | FIRE PATROLS IN PASSENGER SHIPS | 30 |
| 7.9 | FIRE ALARM SIGNALLING SYSTEMS IN PASSENGER SHIPS | 30 |
| 7.10 | PROTECTION OF CABIN BALCONIES ON PASSENGER SHIPS | 31 |
| 8 | CONTROL OF SMOKE SPREAD..... | 32 |
| 8.1 | GENERAL REQUIREMENTS | 32 |
| 8.2 | PROTECTION OF CONTROL STATIONS OUTSIDE MACHINERY SPACES | 32 |
| 8.3 | RELEASE OF SMOKE FROM MACHINERY SPACES | 32 |
| 8.4 | DRAUGHT STOPS | 32 |
| 8.5 | SMOKE EXTRACTION SYSTEMS IN ATRIUMS OF PASSENGER SHIPS | 32 |
| 9 | CONTAINMENT OF FIRE..... | 33 |
| 9.1 | GENERAL REQUIREMENTS | 33 |
| 9.2 | THERMAL AND STRUCTURAL BOUNDARIES | 33 |
| 9.3 | PENETRATIONS IN FIRE-RESISTING DIVISIONS AND PREVENTION OF HEAT TRANSMISSION..... | 47 |
| 9.4 | PROTECTION OF OPENINGS IN FIRE-RESISTING DIVISIONS | 48 |
| 9.5 | PROTECTION OF OPENINGS IN MACHINERY SPACE BOUNDARIES | 50 |
| 9.6 | PROTECTION OF CARGO SPACE BOUNDARIES | 51 |
| 9.7 | VENTILATION SYSTEMS..... | 51 |
| 9.8 | TANKERS (> 60°C)..... | 54 |

| | | |
|-----------|--|-----------|
| 9.9 | SPECIAL PURPOSE SHIPS | 54 |
| 9.10 | OIL RECOVERY SHIPS..... | 54 |
| 9.11 | FIRE FIGHTING SHIPS..... | 55 |
| 10 | FIRE FIGHTING..... | 57 |
| 10.1 | GENERAL REQUIREMENTS..... | 57 |
| 10.2 | WATER SUPPLY SYSTEMS..... | 57 |
| 10.3 | PORTABLE FIRE EXTINGUISHERS | 60 |
| 10.4 | FIXED FIRE-EXTINGUISHING SYSTEMS | 60 |
| 10.5 | FIRE-EXTINGUISHING ARRANGEMENTS IN MACHINERY SPACES..... | 61 |
| 10.6 | FIRE-EXTINGUISHING ARRANGEMENTS IN CONTROL STATIONS, ACCOMMODATION AND SERVICE SPACES | 63 |
| 10.7 | FIRE-EXTINGUISHING ARRANGEMENTS IN CARGO SPACES | 63 |
| 10.8 | CARGO TANK PROTECTION | 64 |
| 10.9 | PROTECTION OF CARGO PUMP-ROOMS IN TANKERS..... | 65 |
| 10.10 | FIRE-FIGHTER’S OUTFITS | 65 |
| 11 | STRUCTURAL INTEGRITY | 67 |
| 11.1 | GENERAL REQUIREMENTS..... | 67 |
| 11.2 | MATERIAL OF HULL, SUPERSTRUCTURES, STRUCTURAL BULKHEADS, DECKS AND DECKHOUSES..... | 67 |
| 11.3 | STRUCTURE OF ALUMINIUM ALLOY..... | 67 |
| 11.4 | MACHINERY SPACES OF CATEGORY A..... | 67 |
| 11.5 | MATERIALS OF OVERBOARD FITTINGS..... | 67 |
| 11.6 | PROTECTION OF CARGO TANK STRUCTURE AGAINST PRESSURE OR VACUUM IN TANKERS | 67 |
| 12 | NOTIFICATION OF CREW AND PASSENGERS..... | 69 |
| 12.1 | GENERAL REQUIREMENTS..... | 69 |
| 12.2 | GENERAL EMERGENCY ALARM SYSTEM..... | 69 |
| 12.3 | PUBLIC ADDRESS SYSTEMS IN PASSENGER SHIPS | 69 |
| 13 | MEANS OF ESCAPE..... | 70 |
| 13.1 | PURPOSE..... | 70 |
| 13.2 | GENERAL REQUIREMENTS..... | 70 |
| 13.3 | MEANS OF ESCAPE FROM CONTROL STATIONS, ACCOMMODATION SPACES AND SERVICE SPACES | 70 |
| 13.4 | MEANS OF ESCAPE FROM MACHINERY SPACES | 72 |
| 13.5 | MEANS OF ESCAPE ON PASSENGER SHIPS FROM SPECIAL CATEGORY AND OPEN RO-RO SPACES TO WHICH ANY PASSENGERS CARRIED CAN HAVE ACCESS..... | 74 |
| 13.6 | MEANS OF ESCAPE FROM RO-RO SPACES | 74 |
| 13.7 | ADDITIONAL REQUIREMENTS FOR RO-RO PASSENGER SHIPS | 74 |
| 14 | OPERATIONAL READINESS AND MAINTENANCE | 75 |
| 14.1 | PURPOSE..... | 75 |
| 14.2 | GENERAL REQUIREMENTS..... | 75 |
| 14.3 | ADDITIONAL REQUIREMENTS FOR PASSENGER SHIPS | 75 |
| 14.4 | ADDITIONAL REQUIREMENTS FOR TANKERS..... | 75 |
| 15 | INSTRUCTIONS, ONBOARD TRAINING AND DRILLS | 76 |
| 15.1 | PURPOSE..... | 76 |
| 15.2 | GENERAL REQUIREMENTS..... | 76 |
| 15.3 | ADDITIONAL REQUIREMENTS FOR PASSENGER SHIPS | 77 |
| 16 | OPERATIONS | 78 |
| 16.1 | GENERAL REQUIREMENTS..... | 78 |
| 16.2 | FIRE SAFETY OPERATIONAL BOOKLETS..... | 78 |
| 16.3 | ADDITIONAL REQUIREMENTS FOR TANKERS..... | 78 |
| 17 | ALTERNATIVE DESIGN AND ARRANGEMENTS | 80 |
| 17.1 | PURPOSE..... | 80 |
| 17.2 | GENERAL..... | 80 |
| 17.3 | ENGINEERING ANALYSIS | 80 |
| 17.4 | EVALUATION OF THE ALTERNATIVE DESIGN AND ARRANGEMENTS | 80 |
| 17.5 | EXCHANGE OF INFORMATION | 80 |

| | | |
|-------------|---|-----------|
| 17.6 | RE-EVALUATION DUE TO CHANGE OF CONDITIONS | 80 |
| 18 | HELICOPTER FACILITIES..... | 81 |
| 18.1 | GENERAL REQUIREMENTS | 81 |
| 18.2 | APPLICATION | 81 |
| 18.3 | STRUCTURE..... | 81 |
| 18.4 | MEANS OF ESCAPE | 81 |
| 18.5 | FIRE-FIGHTING APPLIANCES..... | 81 |
| 18.6 | DRAINAGE FACILITIES | 82 |
| 18.7 | HELICOPTER REFUELLING AND HANGAR FACILITIES | 82 |
| 18.8 | OPERATIONS MANUAL AND FIRE-FIGHTING ARRANGEMENTS..... | 82 |
| 19 | CARRIAGE OF DANGEROUS GOODS | 83 |
| 19.1 | PURPOSE..... | 83 |
| 19.2 | GENERAL REQUIREMENTS | 83 |
| 19.3 | SPECIAL REQUIREMENTS..... | 83 |
| 19.4 | DOCUMENT OF COMPLIANCE..... | 86 |
| 19.5 | ADDITIONAL REQUIREMENTS FOR PASSENGER SHIPS, INCLUDING RO-RO PASSENGER SHIPS | 86 |
| 20 | PROTECTION OF VEHICLE, SPECIAL CATEGORY AND RO-RO SPACES..... | 90 |
| 20.1 | PURPOSE..... | 90 |
| 20.2 | GENERAL REQUIREMENTS | 90 |
| 20.3 | PRECAUTION AGAINST IGNITION OF FLAMMABLE VAPOURS IN CLOSED VEHICLE SPACES, CLOSED RO-RO SPACES AND SPECIAL CATEGORY SPACES | 90 |
| 20.4 | DETECTION AND ALARM | 91 |
| 20.5 | STRUCTURAL FIRE PROTECTION | 92 |
| 20.6 | FIRE EXTINGUCTION..... | 92 |
| 20-1 | REQUIREMENTS FOR VEHICLE CARRIERS CARRYING MOTOR VEHICLES WITH COMPRESSED HYDROGEN OR NATURAL GAS IN THEIR TANKS FOR THEIR OWN PROPULSION AS CARGO | 94 |
| 20-1.1 | PURPOSE..... | 94 |
| 20-1.2 | APPLICATION | 94 |
| 20-1.3 | REQUIREMENTS FOR SPACES INTENDED FOR CARRIAGE OF MOTOR VEHICLES WITH COMPRESSED NATURAL GAS IN THEIR TANKS FOR THEIR OWN PROPULSION AS CARGO | 94 |
| 20-1.4 | REQUIREMENTS FOR SPACES INTENDED FOR CARRIAGE OF MOTOR VEHICLES WITH COMPRESSED HYDROGEN IN THEIR TANKS FOR THEIR OWN PROPULSION AS CARGO..... | 94 |
| 20-1.5 | DETECTION..... | 94 |
| 21 | CASUALTY THRESHOLD, SAFE RETURN TO PORT AND SAFE AREAS | 95 |
| 21.1 | APPLICATION | 95 |
| 21.2 | GENERAL REQUIREMENTS | 95 |
| 21.3 | CASUALTY THRESHOLD | 95 |
| 21.4 | SAFE RETURN TO PORT | 95 |
| 21.5 | SAFE AREA(S)..... | 95 |
| 22 | DESIGN CRITERIA FOR SYSTEMS TO REMAIN OPERATIONAL AFTER A FIRE CASUALTY ... | 96 |
| 22.1 | APPLICATION | 96 |
| 22.2 | GENERAL REQUIREMENTS | 96 |
| 22.3 | SYSTEMS | 96 |
| 23 | SAFETY CENTRE ON PASSENGER SHIPS..... | 97 |
| 23.1 | APPLICATION | 97 |
| 23.2 | GENERAL REQUIREMENTS | 97 |
| 23.3 | LOCATION AND ARRANGEMENT | 97 |
| 23.4 | LAYOUT AND ERGONOMIC DESIGN | 97 |
| 23.5 | COMMUNICATIONS | 97 |
| 23.6 | CONTROL AND MONITORING OF SAFETY SYSTEMS..... | 97 |
| 24 | FIRE SAFETY SYSTEMS | 98 |
| 24.1 | GENERAL REQUIREMENTS | 98 |
| 24.2 | INTERNATIONAL SHORE CONNECTIONS | 98 |

| | | |
|---------------------|--|------------|
| 24.3 | PERSONNEL PROTECTION..... | 98 |
| 24.4 | FIRE EXTINGUISHERS..... | 99 |
| 24.5 | FIXED GAS FIRE-EXTINGUISHING SYSTEMS | 100 |
| 24.6 | FIXED FOAM FIRE-EXTINGUISHING SYSTEMS..... | 103 |
| 24.7 | FIXED PRESSURE WATER-SPRAYING AND WATER-MIST FIRE-EXTINGUISHING SYSTEMS | 107 |
| 24.8 | AUTOMATIC SPRINKLER, FIRE DETECTION AND FIRE ALARM SYSTEMS..... | 107 |
| 24.9 | FIXED FIRE DETECTION AND FIRE ALARM SYSTEMS | 110 |
| 24.10 | SAMPLE EXTRACTION SMOKE DETECTION SYSTEMS | 114 |
| 24.11 | LOW-LOCATION LIGHTING SYSTEMS | 116 |
| 24.12 | FIXED EMERGENCY FIRE PUMPS..... | 116 |
| 24.13 | ARRANGEMENT OF MEANS OF ESCAPE..... | 117 |
| 24.14 | FIXED DECK FOAM SYSTEMS | 122 |
| 24.15 | INERT GAS SYSTEMS | 124 |
| 24.16 | FIXED HYDROCARBON GAS DETECTION SYSTEMS..... | 130 |
| 24.17 | HELICOPTER FACILITY FOAM FIREFIGHTING APPLIANCES..... | 131 |
| 24.18 | DRENCHING SYSTEM..... | 132 |
| 24.19 | DRY POWDER SYSTEM..... | 132 |
| 24.20 | GAS FIRE-EXTINGUISHING SYSTEMS USING MEDIA OTHER THAN CARBON DIOXIDE | 133 |
| 24.21 | FIXED LOCAL APPLICATION FIRE-EXTINGUISHING SYSTEMS | 135 |
| 24.22 | PRESSURE TESTING OF FIRE-EXTINGUISHING SYSTEMS..... | 136 |
| 24.23 | WATER-SCREEN SYSTEM | 136 |
| 25 | FIRE-EXTINGUISHING APPLIANCES, SPARE PARTS AND TOOLS | 138 |
| 25.1 | FIRE-EXTINGUISHING APPLIANCES..... | 138 |
| 25.2 | SPARE PARTS AND TOOLS..... | 146 |
| ANNEX 1 | MATERIALS USED IN ACCOMMODATION SPACES MSC/CIRC. 1120 | 148 |
| ANNEX 2 | PETROLEUM PRODUCTS SUITABLE FOR CARRIAGE IN TANKERS (≤ 60°C) | 151 |
| ANNEX 3 | LIQUID CARGOES (> 60°C)..... | 152 |
| ANNEX 4 | NON COMBUSTIBLE AND LOW FIRE RISK CARGOES / CARGOES FOR WHICH A FIXED GAS FIRE-EXTINGUISHING SYSTEM IS INEFFECTIVE (SOLAS REGULATION II-2/10.7.1 AND 10.7.2)..... | 153 |
| ANNEX 5..... | | 156 |
| 1 | FIRE EXTINGUISHING ARRANGEMENTS..... | 156 |
| 2 | SYSTEMS, APPLIANCES AND EXTINGUISHERS IN MACHINERY SPACES..... | 158 |
| ANNEX 6 | FIRE PROTECTION REQUIREMENTS OF INSTALLATION OF BWMS ON-BOARD SHIPS (IACS UR F45) | 160 |
| 1 | GENERAL | 160 |
| 2 | FIRE CATEGORIZATION | 162 |
| 3 | BWMR LOCATION AND BOUNDARIES..... | 163 |
| 4 | FIRE FIGHTING | 163 |
| 5 | FIRE PREVENTION | 163 |
| 6 | VENTILATION | 164 |
| 7 | PERSONAL EQUIPMENT | 164 |

1 GENERAL

1.1 APPLICATION

1.1.1 The requirements of this Part of the Rules for the classification of ships for the Classification of Ships (hereinafter referred to as: the Rules for the classification of ships), shall apply to ship's structural fire protection, fire-extinguishing systems and fire detection and fire alarm systems as well as to fire-extinguishing appliances and tools on new ships.

Unless expressly provided otherwise, for the application of the present requirements to existing ships see *Rules for the classification of ships, Part 1 - General Requirements, Chapter 1 – General information*, 1.3. See also 1.1.10.

For the purpose of this Part of the Rules for the classification of ships:

- .1 the expression *ships constructed* means ships the keels of which are laid or which are at a similar stage of construction;
- .2 the expression *all ships* means ships, irrespective of type and date of construction;
- .3 a cargo ship, whenever built, which is converted to a passenger ship shall be treated as a passenger ship constructed on the date on which such a conversion commences;
- .4 the expression *a similar stage of construction* means the stage at which construction identifiable with a specific ship begins and assembly of that ship has commenced comprising at least 50 tonnes or one per cent of the estimated mass of all structural material, whichever is less.

This Part of the Rules for the classification of ships includes requirements of Chapter II-2 of SOLAS 1974, as amended, and International Maritime Organization (IMO) Assembly Resolutions specified in the text; in reproducing the above text in this Part of the Rules for the classification of ships applicable for the purpose of classification, the word "Administration", wherever mentioned, has been replaced by the word "Register".

IACS Unified Requirements are included in text of Rules for the classification of ships.

Unified Interpretations are included in text of Rules for the classification of ships and printed in italic text.

Additional classification requirements of the *Register*, where applicable, are stated at the end of the referred head or item or sub-item, as applicable.

1.1.2 In addition to the requirements specified in this Part of the Rules for the classification of ships and in order to define fire-integrity properties of materials and products as well as test procedures for their acceptance, where applicable, the requirements of the Fire Test Procedures Code (FTP Code) shall apply. For ships navigating in Polar waters and Ice class ships, see also the *Rules for the classification of ships for the classification of ships, Part 29 - Polar class ships and Ice class ships*, 7.

1.1.3 The fire protection requirements relating to the machinery and parts thereof, electrical equipment, pumping and piping, fuel and lubrication oil tanks, boilers, refrigerating plants etc. are set out in other relevant Parts of the Rules for the classification of ships.

1.1.4 Unless expressly provided otherwise in this Part of the Rules for the classification of ships, the requirements of this Part of the Rules for the classification of ships shall apply to passenger ships intended for international voyages irrespective of size and to cargo ships of 500 gross tonnage and upwards intended for international voyages.

For ships of less than 24 m in length, requirements of the *Rules for the classification of ships, Part 34 – Rules for the classification of ships for the classification of vessels of less than 24 meters in length, Section 10* applies.

For yachts of 24 m in length and upwards, *Rules for the classification of ships for the classification of ships, Part 35 – Yachts, Section 22* applies.

1.1.5 Where expressly specified in this Part of the Rules for the classification of ships, requirements of this Part of the Rules for the classification of ships may also be applied to:

- .1 passenger ships not intended for international voyages (see 1.1.6);
- .2 cargo ships of less than 500 gross tonnage intended for international voyages (see 1.1.7);
- .3 cargo ships not intended for international voyages (see 1.1.7).

However, the application of the requirements of this Part of the Rules for the classification of ships to ships specified in this item is subject to special consideration by the *Register* in each particular case.

1.1.6 For passenger ships not intended for international voyages, when the Administration of the State whose flag the ship is entitled to fly has issued specific Rules for the classification of ships covering fire protection (e.g. *Directive 2009/45/EC of the European Parliament and of the Council on safety Rules for the classification of ships and standards for passenger ships*, as amended), or instructions regarding acceptance of equivalent Rules for the classification of ships, the *Register* may accept such Rules for the classification of ships for classification purposes in lieu of those given in this Part of the Rules for the classification of ships.

1.1.7 For cargo ships of less than 500 GT intended for international voyages, and for cargo ships not intended for international voyages, when the Administration of the State whose flag the ship is entitled to fly has issued specific Rules for the classification of ships covering fire protection, or instructions regarding acceptance of equivalent Rules for the classification of ships, the *Register* may accept such Rules for the classification of ships for classification purposes in lieu of those given in this Part of the Rules for the classification of ships.

1.1.8 The *Register* may, if it considers that the sheltered nature and conditions of the international voyage are such as to render the application of any specific requirements of this Part of the Rules for the classification of ships unreasonable or unnecessary, exempt from those requirements individual ships or classes of ships which, in the course of their voyage, do not proceed more than 20 nautical miles from the

nearest land. Such exemption shall be, prior to the issuance of exemption certificates, agreed with flag state Administration and affected port State Administration, see *MSC/Circ.606*.

1.1.9 The application of the requirements of this Part of the Rules for the classification of ships to:

- .1 floating units;
- .2 technical floating units;
- .3 passenger ships which are intended for special trades for the carriage of large numbers of special trade passengers, such as the pilgrim trade;

is subject to special consideration by the *Register* in each particular case.

1.1.10 Applicable requirements to existing ships

1.1.10.1 Unless expressly provided otherwise, ships constructed before this Part of the Rules for the classification of ships entered into force shall comply, as a minimum, with the previous requirements of the Rules for the classification of ships applicable at the time the ship was constructed.

Ships constructed before 1 July 2002 shall also comply with:

- .1 requirements in 1.1.11, 1.1.13.5 and 1.1.13.7 as appropriate;
- .2 requirements in 13.3.4.2 to 13.3.4.5, 13.4.3 and Sections 14 to 16, except 16.3.2.2 and 16.3.2.3 thereof, as appropriate;
- .3 requirements in 10.4.1.3 and 10.6.4 for new installations only;
- .4 requirements in 10.5.6 for passenger ships of 2,000 gross tonnage and above;
- .5 requirements in 5.3.1.3.2 and 5.3.4 to passenger ships, and
- .6 requirements in 4.5.7.1.

Ships constructed on or after 1 July 2002 and before 1 July 2010 shall comply with SOLAS, Ch. II-2, Reg. 9, paragraphs 7.1.1, 7.4.4.2, 7.4.4.3 and 7.5.2.1.2 (as adopted by resolution MSC.99(73)).

1.1.10.2 The following existing ships, with cargo spaces intended for the carriage of packaged dangerous goods, shall comply with 19.3, except when carrying dangerous goods specified as classes 6.2 and 7 and dangerous goods in limited quantities (refer to Chapter 3.4 of the IMDG Code) and excepted quantities (refer to Chapter 3.5 of the IMDG Code) in accordance with tables 19.1 and 19.3:

- .1 cargo ships of 500 gross tonnage and upwards and passenger ships constructed on or after 1 September 1984 but before 1 January 2011; and
- .2 cargo ships of less than 500 gross tonnage constructed on or after 1 February 1992 but before 1 January 2011,

and notwithstanding these provisions:

- .3 cargo ships of 500 gross tonnage and upwards and passenger ships constructed on or after 1 September 1984 but before 1 July 1986 need not comply with 19.3.3 provided that they comply with SOLAS, Ch. II-2, regulation 54.2.3 as adopted by resolution MSC.1(XLV);

- .4 cargo ships of 500 gross tonnage and upwards and passenger ships constructed on or after 1 July 1986 but before 1 February 1992 need not comply with 19.3.3 provided that they comply with SOLAS, Ch. II-2, regulation 54.2.3 as adopted by resolution MSC.6(48);
- .5 cargo ships of 500 gross tonnage and upwards and passenger ships constructed on or after 1 September 1984 but before 1 July 1998 need not comply with 19.3.10.1 and 19.3.10.2;
- .6 cargo ships of less than 500 gross tonnage constructed on or after 1 February 1992 but before 1 July 1998 need not comply with regulations 19.3.10.1 and 19.3.10.2;
- .7 cargo ships of 500 gross tonnage and upwards and passenger ships constructed on or after 1 February 1992 but before 1 July 2002 need not comply with 19.3.3 provided that they comply with SOLAS, Ch. II-2, regulation 54.2.3 as adopted by resolution MSC.13(57); and
- .8 cargo ships of 500 gross tonnage and upwards and passenger ships constructed on or after 1 September 1984 but before 1 July 2002 need not comply with 19.3.1, 19.3.5, 19.3.6 and 19.3.9, provided that they comply with SOLAS, Ch. II-2, regulations 54.2.1, 54.2.5, 54.2.6 and 54.2.9 as adopted by resolution MSC.1(XLV).

1.1.10.3 Ships constructed before 1 July 2012 shall also comply with 10.10.1.2.

1.1.10.4 Vehicle carriers constructed before 1 January 2016, including those constructed before 1 July 2012, shall comply with 20-1.2.2.

1.1.10.5 Tankers constructed before 1 January 2016, including those constructed before 1 July 2012, shall comply with 16.3.3 except 16.3.3.3.

1.1.10.6 Requirements in 4.5.5.1.1 and 4.5.5.1.3 apply to ships constructed on or after 1 July 2002 but before 1 January 2016, and 4.5.5.2.1 applies to all ships constructed before 1 January 2016.

1.1.11 Repairs, alterations, modifications and outfitting

1.1.11.1 All existing ships which undergo repairs, alterations, modifications and outfitting related thereto shall continue to comply with at least the requirements previously applicable to these ships. Such ships shall, as a rule, comply with the requirements for new ships to at least the same extent as they did before undergoing such repairs, alterations, modifications or outfitting.

1.1.11.2 Repairs, alterations and modifications which substantially alter the dimensions of a ship or the passenger accommodation spaces, or substantially increase a ship's service life and outfitting related thereto, shall meet the requirements for new ships in so far as the *Register* considers reasonable and practicable, subject to special consideration by the *Register* in each particular case.

1.1.11.3 A cargo ship, whenever built, which is converted to a passenger ship shall be treated as a passenger ship constructed on the date on which such a conversion commences.

1.1.12 Applicable requirements depending on ship type

1.1.12.1 Unless expressly provided otherwise:

- .1 requirements not referring to a specific ship type shall apply to ships of all types; and
- .2 requirements referring to "tankers" shall apply to tankers subject to the requirements specified in 1.1.13.

1.1.13 Application of requirements for tankers

1.1.13.1 Requirements for tankers in this Part of the Rules for the classification of ships shall apply to tankers carrying crude oil or petroleum products having a flashpoint not exceeding 60°C (closed cup test), as determined by an approved flashpoint apparatus, and a Reid vapour pressure which is below atmospheric pressure or other liquid products having a similar fire hazard.

1.1.13.2 Where liquid cargoes other than those referred to in 1.1.13.1 which introduce additional fire hazards are intended to be carried, additional safety measures shall be required, having due regard to the provisions of the *Rules for the classification of ships for the classification of ships, Part 27 – Chemical tankers*.

1.1.13.2.1 A liquid cargo with a flashpoint of less than 60°C for which a regular foam fire-fighting system complying with the Fire Safety Systems Code is not effective, is considered to be a cargo introducing additional fire hazards in this context. The following additional measures are required:

- .1 the foam shall be of alcohol resistant type;
- .2 the type of foam concentrates for use in chemical tankers shall be to the satisfaction of the *Register* taking into account the guidelines developed by the IMO, see Revised Guidelines for the performance and testing criteria, and surveys of foam concentrates for fixed fire-extinguishing systems (*MSC.1/Circ.1312* and *Corr.1*); and
- .3 the capacity and application rates of the foam extinguishing system shall comply with the *Rules for the classification of ships, Part 27 – Chemical tankers*, Section 11, except that lower application rates may be accepted based on performance tests. For tankers fitted with inert gas systems, a quantity of foam concentrate sufficient for 20 min of foam generation may be accepted, see Information on flashpoint and recommended fire-fighting media for chemicals to which neither the IBC nor BCH Codes apply (*MSC/Circ.553*).

1.1.13.2.2 For the purpose of requirements in 1.1.13, a liquid cargo with a vapour pressure greater than 1.013 bar absolute at 37.8 °C is considered to be a cargo introducing additional fire hazards. Ships carrying such substances shall comply with the *Rules for the classification of ships, Part 27 – Chemical tankers*, 15.4. When ships operate in restricted areas

and at restricted times, the Register may agree to waive the requirements for refrigeration systems in accordance with the *Rules for the classification of ships, Part 27 – Chemical tankers*, 15.4.3.

1.1.13.3 Liquid cargoes with a flashpoint exceeding 60°C other than oil products or liquid cargoes subject to the requirements of the *Rules for the classification of ships, Part 27 – Chemical tankers* are considered to constitute a low fire risk, not requiring the protection of a fixed foam extinguishing system.

1.1.13.4 Tankers carrying petroleum products with a flashpoint exceeding 60 °C (closed cup test), as determined by an approved flashpoint apparatus, shall comply with the requirements provided in 10.2.1.4.4 and 10.10.2.3 and the requirements for cargo ships other than tankers, except that, in lieu of the fixed fire extinguishing system required in 10.7, they shall be fitted with a fixed deck foam system which shall comply with the provisions of the Section 24.

1.1.13.5 Combination carriers constructed before, on or after 1 July 2002 shall not carry cargoes other than oil unless all cargo spaces are empty of oil and gas-freed or unless the arrangements provided in each case have been approved by the *Register* taking into account the guidelines developed by IMO, see *Guidelines for inert gas systems (MSC/Circ.353)*, as amended by *MSC/Circ.387*.

1.1.13.6 Chemical tankers shall comply with the requirements for tankers, except where alternative and supplementary arrangements are provided to the satisfaction of *Register*, having due regard to the provisions of the *Rules for the classification of ships, Part 27 – Chemical tankers*.

1.1.13.7 On tankers constructed before 1 July 2002, the requirements of 4.5.10.1.1 and 4.5.10.1.4 and a system for continuous monitoring of the concentration of hydrocarbon gases shall also be fitted. Sampling points or detector heads shall be located in suitable positions in order that potentially dangerous leakages are readily detected. Suitable positions may be the exhaust ventilation duct and lower parts of the pump-room above floor plates. When the hydrocarbon gas concentration reaches a pre-set level which shall not be higher than 10% of the lower flammable limit, a continuous audible and visual alarm signal shall be automatically effected in the pump-room and cargo control room to alert personnel to the potential hazard. However, existing monitoring systems already fitted having a pre-set level not greater than 30% of the lower flammable limit may be accepted.

1.2 SCOPE OF SURVEY AND TECHNICAL DOCUMENTATION

1.2.1 General requirements for supervision of ship during construction as well as the requirements for the documentation to be submitted to the *Register* for consideration and approval are specified in the *Rules for the classification of ships, Part 1 - General Requirements, Chapter 2 – Survey during construction and initial survey*, 1.2.

1.2.2 Subject to supervision by the *Register* during construction of a ship are: structural fire protection, materials used for the interior finishing of ship's spaces with regards to their fire hazardous properties, fire-extinguishing systems, fire detection and fire alarm systems as well as fire-extinguishing

appliances, tools and spare parts specified in this Part of the Rules for the classification of ships.

1.2.3 Subject to supervision by the *Register* during manufacture are:

- .1 constructions and products intended for structural fire protection (division bulk-heads, linings, ceilings, insulation, doors, windows and scuttles);
- .2 materials and products intended for surface finish and furnishing of ship's spaces (veneers, floor coverings, textile and similar materials for upholstery and curtains);
- .3 materials for primary deck coverings;
- .4 items and parts of fire-extinguishing systems: hydrants, fire hoses, couplings, fire hose nozzles, sprinklers, spray nozzles, foam proportionators, generators, monitors, foam nozzles and foam concentrate tanks, inert gas generators, scrubbers and water seals, (see also other relevant Parts of the Rules for the classification of ships);
- .5 fire-extinguishing appliances and tools: fire extinguishers, fireman's outfit, foam concentrate, etc.

The *Register* may request type approval for other materials, equipment, systems or products required by the applicable provisions for ships or installations of special types.

1.2.4 The following plans and particulars shall be submitted to the *Register* for approval of newly applied active fire means intended for fire extinguishing and passive means of structural fire protection:

- .1 copies of Type Approval Certificates (if available), test reports and other essential documents on fire tests run by recognized institutions, confirming compliance of a fire extinguishing medium with the acceptable standards on a composition and application rates, and including information on storage life and conditions;
- .2 copies of Type Approval Certificates (if available) test reports and other essential documents on the fire tests of "A" and "B" class fire divisions including openings and their means of closure for such divisions (including "A" and "B" class doors);
- .3 drawings of "A" and "B" class divisions including details of any joints, where appropriate;
- .4 data on the combustibility of the materials and relevant documents confirming that appropriate tests of the materials concerned were carried out;
- .5 drawings and calculations of the particular equipment of the fire-extinguishing, fire detection and fire alarm systems;
- .6 drawings showing plans and components of ventilation systems for accommodation spaces, control stations, service spaces, workshops, cargo spaces and machinery spaces, essential for fire safety of the ship.

2 FIRE SAFETY OBJECTIVES AND FUNCTIONAL REQUIREMENTS

2.1 FIRE SAFETY OBJECTIVES

2.1.1 The fire safety objectives of this Part of the Rules for the classification of ships are to:

- .1 prevent the occurrence of fire and explosion;
- .2 reduce the risk to life caused by fire;
- .3 reduce the risk of damage caused by fire to the ship, its cargo and the environment;
- .4 contain, control and suppress fire and explosion in the compartment of origin; and
- .5 provide adequate and readily accessible means of escape for passengers and crew.

2.2 FUNCTIONAL REQUIREMENTS

2.2.1 In order to achieve the fire safety objectives set out in 2.1, the following functional requirements are embodied in the Sections of this Part of the Rules for the classification of ships as appropriate:

- .1 division of the ship into main vertical and horizontal zones by thermal and structural boundaries;
- .2 separation of accommodation spaces from the remainder of the ships by thermal and structural boundaries;
- .3 restricted use of combustible materials;
- .4 detection of any fire in the zone of origin;
- .5 containment and extinction of any fire in the space of origin;
- .6 protection of means of escape and access for firefighting;
- .7 ready availability of fire-extinguishing appliances; and
- .8 minimization of possibility of ignition of flammable cargo vapour.

2.3 ACHIEVEMENT OF THE FIRE SAFETY OBJECTIVES

2.3.1 The fire safety objectives set out in 2.1 shall be achieved by ensuring compliance with the prescriptive requirements specified in Sections 3 to 16 and 18 to 25, as applicable; or by alternative design and arrangements which comply with Section 17. A ship shall be considered to meet the functional requirements set out in 2.2 and to achieve the fire safety objectives set out in 2.1 when either:

- .1 the ship's design and arrangements, as a whole, comply with the relevant prescriptive requirements in Sections 3 to 16 and 18 to 25, as applicable;
- .2 the ship's design and arrangements, as a whole, have been reviewed and approved in accordance with Section 17; or
- .3 part(s) of the ship's design and arrangements have been reviewed and approved in accordance with Section 17 and the remaining parts of the ship comply with the relevant prescriptive requirements in Sections 3 to 16 and 18 to 25, as applicable.

3 DEFINITIONS AND EXPLANATIONS

3.1 DEFINITIONS

3.1.1 Definitions and explanations relating to the general terminology of the Rules for the classification of ships are given in Rules for the classification of ships, *Part 1 - General Requirements, Chapter 1 – General information, Section 2*. For other definitions and explanations see other relevant Parts of the Rules for the classification of ships.

3.1.2 For the purpose of this Part of the Rules for the classification of ships the following definitions are adopted:

- .1 *Accommodation spaces* – those spaces used for public spaces, corridors, lavatories, cabins, offices, hospitals, cinemas, game and hobby rooms, barber shops, pantries containing no cooking appliances and similar spaces.

See *MSC.1/Circ.1436*.

- .2 *“A” class divisions* – those divisions formed by bulkheads and decks which comply with the following:

- .1 they shall be constructed of steel or other equivalent material;
.2 they shall be suitably stiffened;
.3 they shall be so constructed as to be capable of preventing the passage of smoke and flame to the end of the one-hour standard fire test (see FTP Code);
.4 they shall be insulated with approved non-combustible materials such that the average temperature of the unexposed side will not rise more than 140 °C above the original temperature, nor will the temperature, at any one point, including any joint, rise more than 180 °C above the original temperature.

Depending on the time within which the above-indicated temperature rise is ensured in the course of the standard fire test, they may be assigned the following fire integrity standards:

- .4.1 Class "A-60" for 60 min;
.4.2 Class "A-30" for 30 min;
.4.3 Class "A-15" for 15 min;
.4.4 Class "A-0" for 0 min.

Register requires a test of a prototype bulkhead or deck in accordance with the Fire Test Procedures Code to ensure that it meets the above requirements for integrity and temperature rise. Insulated “A” class bulkheads and decks used on board ships, including the means of affixing the insulation to the “A” class structural members, shall be consistent with the materials, details and arrangements used during, and documented in the test reports issued for the approval test for that insulating material (see *MSC.1/Circ.1434*).

See also *IACS UI SC239*.

- .3 *Atriums* – public spaces within a single main vertical zone spanning three or more open decks.

- .4 *“B” class divisions* – those divisions formed by bulkheads, decks, ceilings or linings which comply with the following:

- .1 they shall be constructed of approved noncombustible materials (combustible veneers are permitted, if in compliance with other applicable requirements of this part of the Rules for the classification of ships);

- .2 they shall be constructed as to be capable of preventing the passage of flame to the end of the first half an hour of the standard fire test (see FTP Code).

- .3 they shall have an insulation value such that the average temperature of the unexposed side will not rise more than 140 °C above the original temperature, nor will the temperature at any one point, including any joint, rise more than 225 °C above the original temperature.

Depending on the time within which the above-indicated temperature rise is ensured in the course of the standard fire test, they may be assigned the following fire integrity standards:

- .3.1 Class "B-15" for 15 minutes;
.3.2 Class "B-0" for 0 minutes.

Register requires a test of a prototype division in accordance with the Fire Test Procedures Code to ensure that it meets the above requirements for integrity and temperature rise.

“B” class divisions used on board ships shall be consistent with the materials, details and arrangements used during, and documented in the test reports issued for, the approval test for that divisions.

The type approval process for all “B” class panels to which handrails are attached on ro-ro passenger ships shall include a suitable structural test (see *MSC/Circ. 910*).

See *IACS UI SC125 Rev.3*.

- .5 *Bulkhead deck* – the uppermost deck up to which the transverse watertight bulkheads are carried.

- .6 *Cargo area* – that part of the ship that contains, cargo tanks, slop tanks and cargo pump-rooms including pump-rooms, cofferdams, ballast and void spaces adjacent to cargo tanks and also deck areas throughout the entire length and breadth of the part of the ship over the aforementioned spaces. See *IACS UI SC211/Corr.1*.

- .7 *Cargo ship* – any ship which is not a passenger ship.

- .8 *Cargo spaces* – spaces used for cargo (such as ro-ro spaces, vehicle spaces, container spaces, general cargo, bulk cargo and refrigerated cargo spaces and similar), cargo oil tanks, cargo tanks for liquids other than oil cargo and trunks to such spaces.
- .9 *Central control station* – a control station in which the following control and indicator functions are centralized:
- .1 fixed fire detection and fire alarm systems;
 - .2 automatic sprinkler, fire detection and fire alarm systems;
 - .3 fire door indicator panels;
 - .4 fire door closure;
 - .5 watertight door indicator panels;
 - .6 watertight door closures;
 - .7 ventilation fans;
 - .8 general/fire alarms;
 - .9 communication system including telephones; and
 - .10 microphones to public address systems.
- .10 *“C” class divisions* – fire-resisting divisions constructed of approved non-combustible materials. They need meet neither requirements relative to the passage of smoke and flame nor limitations relative to the temperature rise. Combustible veneers are permitted provided they meet the requirements of this Part of the Rules for the classification of ships. See *IACS UI SC125 Rev.3*.
- .11 *Chemical tanker* – a cargo ship constructed or adapted and used for the carriage in bulk of any liquid product of a flammable nature listed in Chapter 17 of the International Bulk Chemical Code.
- .12 *Closed ro-ro spaces* – ro-ro spaces which are neither open ro-ro spaces nor weather decks.
- .13 *Closed vehicle spaces* – vehicle spaces which are neither open vehicle spaces nor weather decks.
- .14 *Combination carrier* – a cargo ship designed to carry both oil and solid cargoes in bulk.
- .15 *Combustible material* – any material other than a non-combustible material.
- .16 *Continuous “B” class ceilings or linings* – those “B” class ceilings or linings which terminate at an “A” or “B” class division.
- .17 *Continuously manned central control station* – a central control station which is continuously manned by a responsible member of the crew.
- .18 *Control stations* – those spaces in which the ship’s radio or main navigating equipment or the emergency source of power is located or where the fire recording or fire control equipment is centralized. Spaces where the fire recording or fire control equipment is centralized are also considered to be a fire control station. Control stations are also:
- Safety center dedicated to the management of emergency situations.
 - Control room for propulsion machinery when located outside the machinery spaces.
 - Spaces in which the following battery sources regardless of battery capacity are located:
 - .1 emergency batteries for power supply from blackout till start of emergency generator;
 - .2 emergency batteries as reserve source of energy to radiotelegraph installation;
 - .3 batteries for start of emergency generator; and
 - .4 in general, all emergency batteries required in the *Rules for the classification of ships, Part 12 – Electrical Equipment*, Section 9.
- See also *IACS UI SC17 Rev.3* and *IACS UI SC260 Rev.1*.
- .19 *Crude oil* – any oil occurring naturally in the earth, whether or not treated to render it suitable for transportation, and includes crude oil where certain distillate fractions may have been removed from or added to.
- .20 *Dangerous goods* – for transport by sea, substances, materials and articles as specified and classified in the IMDG Code, as amended, and carried in packaged form or in solid form in bulk. Dangerous goods are subdivided into the following classes:
- Class 1: Explosives;
 - Class 2: Gasses compressed, liquefied or dissolved under pressure;
 - Class 3: Flammable liquids;
 - Class 4: Flammable solids; substances liable to spontaneous combustion; and substances which, in contact with water, emit flammable gases;
 - Class 5: Oxidizing substances and organic peroxides;
 - Class 6: Toxic substances and infectious substances;
 - Class 7: Radioactive materials;
 - Class 8: Corrosives;
 - Class 9: Miscellaneous dangerous substances and articles (for which experience has shown, or may show, to be of such a dangerous character that the requirements of this Part of the Rules for the classification of ships shall apply to it).
- .21 *Deadweight* – the difference in tonnes between the displacement of a ship in water of a specific gravity of 1.025 at the load waterline corresponding to the assigned summer freeboard and the lightweight of the ship. See *MSC.1/Circ.1573*.

- .22 *Fire Safety Systems Code* – the International Code for Fire Safety Systems (FSS Code), as adopted by resolution MSC.98(73), as amended by resolutions MSC.206(81), MSC.217(82), MSC.292(87), MSC.311(88), MSC.327(90), MSC.339(91) and MSC.367(93). FSS Code is included in text of this Part of the Rules for the classification of ships (in Section 24).
- .23 *Fire Test Procedures Code* – the International Code for Application of Fire Test Procedures, 2010 (2010 FTP Code), as adopted by resolution MSC.307(88), as amended by resolution MSC.437(99); taking into account IMO interpretations (*MSC.1/Circ.1435*, *MSC.1/Circ.1456* and *MSC.1/Circ.1488*), IMO Recommendation (*MSC.1/Circ.1435*) and IACS unified interpretations *UI FTP 2*, *UI FTP3 Rev.3*, *UI FTP4, Rev.2*, *UI FTP5, Corr.1* and *UI FTP6 Rev.1*.
- .24 *Flashpoint* – the temperature in degrees Celsius (closed cup test) at which a product will give off enough flammable vapour to be ignited, as determined by an approved flashpoint apparatus.
- .25 *Gas carrier* – a cargo ship constructed or adapted and used for the carriage in bulk of any liquefied gas or other products of a flammable nature listed in Chapter 19 of the International Gas Carrier Code. Not applicable for services classification provided by the Register.
- .26 *Helideck* – a purpose-built helicopter landing area located on a ship including all structure, fire-fighting appliances and other equipment necessary for the safe operation of helicopters.
- .27 *Helicopter facility* – a helideck including any refuelling and hangar facilities.
- .28 *Lightweight* – the displacement of a ship in tonnes without cargo, fuel, lubricating oil, ballast water, fresh water and feedwater in tanks, consumable stores, and passengers and crew and their effects.
See *IACS UI SC273*.
- .29 *Low flame-spread* – means that the surface thus described will adequately restrict the spread of flame, this being determined in accordance with the Fire Test Procedures Code.
- .30 *Machinery spaces* – machinery spaces of category A and other spaces containing propulsion machinery, boilers, oil fuel units, steam and internal combustion engines, generators and major electrical machinery, oil filling stations, refrigerating, stabilizing, ventilation and air conditioning machinery, and similar spaces, and trunks to such spaces. See *IACS UI SC294*.
- .31 *Machinery spaces of category A* – those spaces and trunks to such spaces which contain either:
- .1 internal combustion machinery used for main propulsion;
 - .2 internal combustion machinery used for purposes other than main propulsion where such machinery has in the aggregate a total power output of not less than 375 kW; or
 - .3 any oil-fired boiler or oil fuel unit, or any oil-fired equipment other than boilers, such as inert gas generators, incinerators, etc.
- .32 *Main vertical zones* – those sections into which the hull, superstructure and deck-houses are divided by A” class divisions, the mean length and width of which on any deck does not in general exceed 40 m.
- .33 *Non-combustible material* – a material which neither burns nor gives off flammable vapours in sufficient quantity for self-ignition when heated to approximately 750°C, this being determined in accordance with the Fire Test Procedures Code.
- .34 *Oil fuel unit* – any equipment used for the preparation and delivery of oil fuel, heated or not, to boilers (including inert gas generators) and engines (including gas turbines) at a pressure of more than 0.18 N/mm². Oil fuel transfer pumps are not considered as oil fuel units (see *MSC.1/Circ.1203*). See also *IACS UI SC16 Rev.2*.
- .35 *Open ro-ro spaces* – those ro-ro spaces which are either open at both ends or have an opening at one end, and are provided with adequate natural ventilation effective over their entire length through permanent openings distributed in the side plating or deckhead or from above, having a total area of at least 10% of the total area of the space sides.
- .36 *Open vehicle spaces* – those vehicle spaces which are either open at both ends or have an opening at one end and are provided with adequate natural ventilation effective over their entire length through permanent openings distributed in the side plating or deckhead or from above, having a total area of at least 10% of the total area of the space sides.
- .37 *Passenger ship* – a ship which carries more than twelve passengers.
- .38 *Prescriptive requirements* – the construction characteristics, limiting dimensions, or fire safety systems specified in this Part of this part of the Rules for the classification of ships, except in Section 17.
- .39 *Public spaces* – those portions of the accommodation which are used for halls, dining rooms, lounges and similar permanently enclosed spaces.
- .40 *Rooms containing furniture and furnishings of restricted fire risk* – for the purpose of Section 9, those rooms containing furniture and furniture and furnishings of re-

stricted fire risk (whether cabins, public spaces, offices or other types of accommodation) in which:

- .1 case furniture such as desks, wardrobes, dressing tables, bureaux, or dressers are constructed entirely of approved non-combustible materials, except that a combustible veneer not exceeding 2 mm may be used on the working surface of such articles;
 - .2 free-standing furniture such as chairs, sofas, or tables are constructed with frames of non-combustible materials;
 - .3 draperies, curtains and other suspended textile materials have qualities of resistance to the propagation of flame not inferior to those of wool having a mass of 0.8 kg/m², this being determined in accordance with the Fire Test Procedures Code;
 - .4 floor coverings have low flame-spread characteristics;
 - .5 exposed surfaces of bulkheads, linings and ceilings have low flame-spread characteristics;
 - .6 upholstered furniture has qualities of resistance to the ignition and propagation of flame, this being determined in accordance with the Fire Test Procedures Code; and
 - .7 bedding components have qualities of resistance to the ignition and propagation of flame, this being determined in accordance with the Fire Test Procedures Code.
- .41 *Ro-ro spaces* – cargo spaces not normally subdivided in any way and normally extending to either a substantial length or the entire length of the ship in which motor vehicles with fuel in their tanks for their own propulsion and/or goods (packaged or in bulk, in or on rail or road cars, vehicles, including road or rail tankers), trailers, containers, pallets, demountable tanks or in or on similar stowage units or other receptacles) can be loaded and unloaded normally in a horizontal direction.
 - .42 *Ro-ro passenger ship* – a passenger ship with ro-ro spaces or special category spaces.
 - .43 *Steel or other equivalent material* – any non-combustible material which, by itself or due to insulation provided, has structural and integrity properties equivalent to steel at the end of the applicable exposure to the standard fire test (e.g., aluminium alloy with appropriate insulation).
 - .44 *Sauna* – a hot room with temperatures normally varying between 80°C and 120°C where the heat is provided by a hot surface (e.g., by an electrically heated oven). The hot room may also include the space where the oven is located and adjacent bathrooms.
 - .45 *Service spaces* – spaces used for galleys, pantries containing cooking appliances, lockers, mail and specie rooms, store-rooms, work-shops other than those forming part of the machinery spaces, and similar spaces and trunks to such spaces.
For further clarification regarding distinguishing between galleys and pantries, regarding applicable fire protection requirements, see *MSC.1/Circ.1436*.
 - .46 *Special category spaces* – enclosed vehicle spaces above and below the bulkhead deck, into and from which vehicles can be driven and to which passengers have access. Special category spaces may be accommodated on more than one deck provided that the total overall clear height for vehicles does not exceed 10 m.
 - .47 *Standard fire test* – a test in which specimens of the relevant bulkheads or decks are exposed in a test furnace to temperatures corresponding approximately to the standard time-temperature curve in accordance with the test method specified in the FTP Code.
 - .48 *Tanker* – a cargo ship constructed or adapted for the carriage in bulk of liquid cargoes of an inflammable nature. Oil tankers shall be considered (see IACS UR F6, Rev. 1) as vessels capable of carrying oil having a flash point not exceeding 60°C (closed cup test).
 - .49 *Vehicle spaces* – cargo spaces intended for carriage of motor vehicles with fuel in their tanks for their own propulsion.
 - .50 *Weather deck* – a deck which is completely exposed to the weather from above and from at least two sides.
 - .51 *Safe area* – in the context of a casualty and from the perspective of habitability, any area(s) which is not flooded or which is outside the main vertical zone(s) in which a fire has occurred such that it can safely accommodate all persons onboard to protect them from hazards to life or health and provide them with basic services.
 - .52 *Safety centre* – a control station dedicated to the management of emergency situations. Safety systems' operation, control and/or monitoring are an integral part of the safety centre.
 - .53 *Cabin balcony* – an open deck space which is provided for the exclusive use of the occupants of a single cabin and has direct access from such a cabin.
 - .54 *Fire damper* (for the purpose of implementing of Head 9.7) - a device installed in a ventilation duct, which under normal conditions remains open allowing flow in the duct, and is closed during a fire, preventing the flow in the duct to restrict the passage of fire. In using the above definition the following terms may be associated:

- .1 *automatic fire damper* is a fire damper that closes independently in response to exposure to fire products;
 - .2 *manual fire damper* is a fire damper that is intended to be opened or closed by the crew by hand at the damper itself; and
 - .3 *remotely operated fire damper* is a fire damper that is closed by the crew through a control located at a distance away from the controlled damper.
- .55 *Smoke damper* (for the purpose of implementing regulation 9.7) - a device installed in a ventilation duct, which under normal conditions remains open allowing flow in the duct, and is closed during a fire, preventing the flow in the duct to restrict the passage of smoke and hot gases. A smoke damper is not expected to contribute to the integrity of a fire rated division penetrated by a ventilation duct. In using the above definition the following terms may be associated:
- .1 *automatic smoke damper* is a smoke damper that closes independently in response to exposure to smoke or hot gases;
 - .2 *manual smoke damper* is a smoke damper intended to be opened or closed by the crew by hand at the damper itself; and
 - .3 *remotely operated smoke damper* is a smoke damper that is closed by the crew through a control located at a distance away from the controlled damper.
- .56 *Vehicle carrier* - a cargo ship which only carries cargo in ro-ro spaces or vehicle spaces, and which is designed for the carriage of unoccupied motor vehicles without cargo, as cargo.
See *MSC.1/Circ.1555*.
- .57 *Helicopter landing area* - an area on a ship designated for occasional or emergency landing of helicopters but not designed for routine helicopter operations.
- .58 *Winching area* - a pick-up area provided for the transfer by helicopter of personnel or stores to or from the ship, while the helicopter hovers above the deck.

3.1.3 For the purpose of this Part of the Rules for the classification of ships the following additional definitions are adopted:

- .1 *Non-sparking fan* - a fan that complies with the requirements of IACS UR F29 Rev. 6.
- 2 *Ballast Water Management System (BWMS)* - a system for treatment of ballast water. Additional fire safety measures when BWMS is installed on board ship shall be in compliance with the requirements of Annex VI (*IACS UR F 45*).

4 PROBABILITY OF IGNITION

4.1 GENERAL REQUIREMENTS

4.1.1 The purpose of this Section is to prevent the ignition of combustible materials or flammable liquids. For this purpose, the following functional requirements shall be met:

- .1 means shall be provided to control leaks of flammable liquids;
- .2 means shall be provided to limit the accumulation of flammable vapours;
- .3 the ignitability of combustible materials shall be restricted;
- .4 ignition sources shall be restricted;
- .5 ignition sources shall be separated from combustible materials and flammable liquids; and
- .6 the atmosphere in cargo tanks shall be maintained out of the explosive range.

For application of materials other than steel on engine, turbine and gearbox installations see *MSC.1/Circ.1527*.

4.2 ARRANGEMENTS FOR OIL FUEL, LUBRICATION OIL AND OTHER FLAMMABLE OILS

4.2.1 Limitations in the use of oils as fuel

The following limitations shall apply to the use of oil as fuel:

- .1 except as otherwise permitted by this item, no oil fuel with a flashpoint of less than 60°C shall be used, see *Recommended procedures to prevent the illegal or accidental use of low flashpoint cargo oil as fuel* (resolution A.565(14));
- .2 in emergency generators, oil fuel with a flashpoint of not less than 43°C may be used;
- .3 the use of oil fuel having a flashpoint of less than 60°C but not less than 43°C may be permitted (e.g. for feeding the emergency fire pump's engines and the auxiliary machines which are not located in the machinery spaces of category A) subject to the following:
 - .3.1 fuel oil tanks except those arranged in double-bottom compartments shall be located outside of machinery spaces of category A;
 - .3.2 provisions for the measurement of oil temperature are provided on the suction pipe of the oil fuel pump;
 - .3.3 stop valves and/or cocks are provided on the inlet side and outlet side of the oil fuel strainers; and

- .3.4 pipe joints of welded construction or of circular cone type or spherical type union joint are applied as much as possible;
- .4 in cargo ships, to which part G of SOLAS, Ch. II-1 is not applicable, the use of oil fuel having a lower flashpoint than otherwise specified in 4.2.1.1, for example crude oil, may be permitted provided that such fuel is not stored in any machinery space and subject to the approval by the *Register* of the complete installation; and
- .5 in ships, to which part G of Chapter II-1 is applicable, the use of oil fuel having a lower flashpoint than otherwise specified in 4.2.1.1 is permitted.

In addition, the requirements specified in *Rules for the classification of ships, Part 7 - Machinery installation, 1.1, Part 8 - Piping, 8 and Part 9 - Machines, 2.6* shall be complied with

4.2.2 Arrangements for oil fuel

In a ship in which oil fuel is used, the arrangements for the storage, distribution and utilization of the oil fuel shall be such as to ensure the safety of the ship and persons on board and shall at least comply with the following provisions.

Following additional requirements (IACS UR F35, Rev. 8) apply:

Oil fuel in storage tanks should not be heated to temperatures within 10°C below the flash point of the fuel oil, except that where oil fuel in service tanks, settling tanks and any other tanks in supply system is heated the following arrangements shall be provided:

- .1 the length of the vent pipes from such tanks and/or a cooling device is sufficient for cooling the vapours to below 60°C, or the outlet of the vent pipes is located 3m away from a source of ignition;
- .2 the vent pipes are fitted with flame screens;
- .3 there are no openings from the vapour space of the fuel tanks into machinery spaces (bolted manholes are acceptable);
- .4 enclosed spaces are not located directly over such fuel tanks, except for vented cofferdams;
- .5 electrical equipment is not fitted in the vapour space of the tanks, unless it is certified to be intrinsically safe.

4.2.2.1 Location of oil fuel systems

As far as practicable, parts of the oil fuel system containing heated oil under pressure exceeding 0.18 N/mm² shall not be placed in a concealed position such that defects and leakage cannot readily be observed. The machinery spaces in way of such parts of the oil fuel system shall be adequately illuminated.

4.2.2.2 Ventilation of machinery spaces

The ventilation of machinery spaces shall be sufficient under normal conditions to prevent accumulation of oil vapour.

4.2.2.3 Oil fuel tanks

- .1 Fuel oil, lubrication oil and other flammable oils shall not be carried in forepeak tanks.
- .2 As far as practicable, oil fuel tanks shall be part of the ship's structure and shall be located outside machinery spaces of category A. Where oil fuel tanks, other than double-bottom tanks, are necessarily located adjacent to or within machinery spaces of category A, at least one of their vertical sides shall be contiguous to the machinery space boundaries, and shall preferably have a common boundary with the double bottom tanks, and the area of the tank boundary common with the machinery spaces shall be kept to a minimum, see *MSC.1/Circ.1322*. Where such tanks are situated within the boundaries of machinery spaces of category A they shall not contain oil fuel having a flashpoint of less than 60°C. In general, the use of free-standing oil fuel tanks shall be avoided. When such tanks are employed their use shall be prohibited in category A machinery spaces on passenger ships. Where permitted, they shall be placed in an oil-tight spill tray of ample size having a suitable drain pipe leading to a suitably sized spill oil tank.
- .3 No oil fuel tank shall be situated where spillage or leakage therefrom can constitute a fire or explosion hazard by falling on heated surfaces.
- .4 Oil fuel pipes, which, if damaged, would allow oil to escape from a storage, settling or daily service tank having a capacity of 500 liters and above situated above the double bottom, shall be fitted with a cock or valve directly on the tank capable of being closed from a safe position outside the space concerned in the event of a fire occurring in the space in which such tanks are situated. In the special case of deep tanks situated in any shaft or pipe tunnel or similar space, valves on the tank shall be fitted, but control in the event of fire may be effected by means of an additional valve on the pipe or pipes outside the tunnel or similar space. If such an additional valve is fitted in the machinery space, it shall be operated from a position outside this space. The controls for remote operation of the valve for the emergency generator fuel tank shall be in a separate location from the controls for remote operation of other valves for tanks located in machinery spaces, see *MSC/Circ.1037*.
- .5 Safe and efficient means of ascertaining the amount of oil fuel contained in any oil fuel tank shall be provided.
 - .5.1 Where sounding pipes are used, they shall not terminate in any space where the risk of ignition of spillage from the sounding

pipe might arise. In particular, they shall not terminate in passenger or crew spaces. As a general rule, they shall not terminate in machinery spaces. However, where the *Register* considers that these latter requirements are impracticable, it may permit termination of sounding pipes in machinery spaces on condition that all of the following requirements are met:

- (1) an oil-level gauge is provided meeting the requirements of 4.2.2.3.5.2;
- (2) the sounding pipes terminate in locations remote from ignition hazards unless precautions are taken, such as the fitting of effective screens, to prevent the oil fuel in the case of spillage through the terminations of the sounding pipes from coming into contact with a source of ignition; and
- (3) the terminations of sounding pipes are fitted with self-closing blanking devices and with a small-diameter self-closing control cock located below the blanking device for the purpose of ascertaining before the blanking device is opened that oil fuel is not present. Provisions shall be made so as to ensure that any spillage of oil fuel through the control cock involves no ignition hazard.

Following additional requirements (IACS UR F35, Rev. 8) apply:

Short sounding pipes may be used for tanks other than double bottom tanks without the additional closed level gauge provided an overflow system is fitted.

- .5.2 Other oil-level gauges may be used in place of sounding pipes subject to the following conditions:
 - (1) in passenger ships, such gauges shall not require penetration below the top of the tank and their failure or overflowing of the tanks shall not permit release of fuel; and
 - (2) in cargo ships, the failure of such gauges or overflowing of the tank shall not permit release of fuel into the space. The use of cylindrical gauge glasses is prohibited. The *Register* may permit the use of oil-level gauges with flat glasses and self-closing valves between the gauges and fuel tanks.
- .5.3 The means prescribed in 4.2.2.3.5.2 which are acceptable to the *Register* shall be maintained in the proper condition to ensure their continued accurate functioning in service.

Following additional requirement (IACS UR F35, Rev. 8) applies:

Level switches may be used below the tank top provided they are contained in a steel enclosure or other enclosures not capable of being destroyed by fire.

4.2.2.4 Prevention of overpressure

Provisions shall be made to prevent overpressure in any oil tank or in any part of the oil fuel system, including the filling pipes served by pumps on board. Air and overflow pipes and relief valves shall discharge to a position where there is no risk of fire or explosion from the emergence of oils and vapour and shall not lead into crew spaces, passenger spaces nor into special category spaces, closed ro-ro spaces, machinery spaces or similar spaces.

Following additional requirements (IACS UR F35, Rev. 8) apply:

- .1 Air pipes from oil fuel tanks should be led to a safe position on the open deck. Air pipes from lubricating oil storage tanks may terminate in the machinery space, provided that the open ends are so situated that issuing oil cannot come into contact with electrical equipment or heated surfaces.
- .2 Any overflow pipe should have a sectional area of at least 1,25 times that of the filling pipe and should be led to an overflow tank of adequate capacity or to a storage tank having space reserved for overflow purposes.
- .3 An alarm device should be provided to give warning when the oil reaches a predetermined level in the tank, or alternatively, a sight glass should be provided in the overflow pipe to indicate when any tank is overflowing. Such sight glasses should be placed on vertical pipes only and in readily visible positions.

4.2.2.5 Oil fuel piping

- .1 Oil fuel pipes and their valves and fittings shall be of steel or other approved material, see *IACS UI SC282*, except that restricted use of flexible pipes shall be permissible in positions where the *Register* is satisfied that they are necessary, see *recommendations published by the International Organization for Standardization, in particular publications ISO 15540:1999, Fire resistance of hose assemblies – test methods and ISO 15541:1999, Fire resistance of hose assemblies – requirements for the test bench*. Such flexible pipes and end attachments shall be of approved fire-resisting materials of adequate strength and shall be constructed to the satisfaction of the *Register*. For valves fitted to oil fuel tanks and under static pressure, steel or spheroidal-graphite cast iron may be accepted. However, ordinary cast iron valves may be used in piping systems where the design pressure is lower than 7 bar and the design temperature is below 60°C.

Following additional requirement (IACS UR F35, Rev. 8) applies:

Hose clamps and similar types of attachments for flexible pipes should not be permitted.

- .2 External high-pressure fuel delivery lines between the high-pressure fuel pumps and fuel injectors shall be protected with a jacketed piping system capable of containing fuel from a high-pressure line failure. A jacketed pipe incorporates an outer pipe into which the high-pressure fuel pipe is placed, forming a permanent assembly. The jacketed piping system shall include a means for collection of leakages and arrangements shall be provided with an alarm in case of a fuel line failure.
- .3 Oil fuel lines shall not be located immediately above or near units of high temperature, including boilers, steam pipelines, exhaust manifolds, silencers or other equipment required to be insulated by 4.2.2.6. As far as practicable, oil fuel lines shall be arranged far apart from hot surfaces, electrical installations or other sources of ignition and shall be screened or otherwise suitably protected to avoid oil spray or oil leakage onto the sources of ignition. The number of joints in such piping systems shall be kept to a minimum.
- .4 Components of a diesel engine fuel system shall be designed considering the maximum peak pressure which will be experienced in service, including any high-pressure pulses which are generated and transmitted back into the fuel supply and spill lines by the action of fuel injection pumps. Connections within the fuel supply and spill lines shall be constructed having regard to their ability to prevent pressurized oil fuel leaks while in service and after maintenance.
- .5 In multi-engine installations which are supplied from the same fuel source, means of isolating the fuel supply and spill piping to individual engines shall be provided. The means of isolation shall not affect the operation of the other engines and shall be operable from a position not rendered inaccessible by a fire on any of the engines. This requirement is considered satisfied if operating position is located at least 5 m away from engines in any direction. If this is not possible, operating position should be protected from fire by an obstruction. The application of this criterion is not mandatory for ship of less than 500 gross tonnage navigating in restricted navigation areas 5 to 8.
- .6 Where the *Register* may permit the conveying of oil and combustible liquids through accommodation and service spaces, the pipes conveying oil or combustible liquids shall be of a material approved by the *Register* having regard to the fire risk.

4.2.2.6 Protection of high-temperature surfaces

- .1 Surfaces with temperatures above 220°C which may be impinged as a result of a

fuel system failure shall be properly insulated.

- .2 Precautions shall be taken to prevent any oil that may escape under pressure from any pump, filter or heater from coming in contact with heated surfaces.

4.2.2.7 In addition, the requirements specified in the *Rules for the classification of ships, Part 7 - Machinery installation*, 1.11 and 1.12 and in the *Rules for the classification of ships, Part 9 - Machines*, 2.6 shall be complied with.

4.2.3 Arrangements for lubricating oil

4.2.3.1 The arrangements for the storage, distribution and utilization of oil used in pressure lubrication systems shall be such as to ensure the safety of the ship and persons on board. The arrangements made in machinery spaces of category A, and whenever practicable in other machinery spaces, shall at least comply with the provisions of 4.2.2.1, 4.2.2.3.3, 4.2.2.3.4, 4.2.2.3.5, 4.2.2.4, 4.2.2.5.1, 4.2.2.5.3 and 4.2.2.6, except that:

- .1 this does not preclude the use of sight-flow glasses in lubricating systems provided that they are shown by testing to have a suitable degree of fire resistance; and
- .2 sounding pipes may be authorized in machinery spaces; however, the requirements of 4.2.2.3.5.1(1) and 4.2.2.3.5.1(3) need not be applied on condition that the sounding pipes are fitted with appropriate means of closure.

4.2.3.2 The provisions of 4.2.2.3.4 shall also apply to lubricating oil tanks except those having a capacity less than 500 liters, storage tanks on which valves are closed during the normal operation mode of the ship, or where it is determined that an unintended operation of a quick-closing valve on the oil lubricating tank would endanger the safe operation of the main propulsion and essential auxiliary machinery.

4.2.3.3 In addition, the requirements specified in the *Rules for the classification of ships, Part 8 - Piping*, 9 and *Part 9 - Machines*, 2.7 shall be complied with.

4.2.4 Arrangements for other flammable oils

4.2.4.1 The arrangements for the storage, distribution and utilization of other flammable oils employed under pressure in power transmission systems, control and activating systems and heating systems shall be such as to ensure the safety of the ship and persons on board. Suitable oil collecting arrangements for leaks shall be fitted below hydraulic valves and cylinders. In locations where means of ignition are present, such arrangements shall at least comply with the provisions of 4.2.2.3.3, 4.2.2.3.5, 4.2.2.5.3 and 4.2.2.6 and with the provisions of 4.2.2.4 and 4.2.2.5.1 in respect of strength and construction, see *MSC/Circ.1037*.

4.2.4.2 In addition, the requirements specified in the *Rules for the classification of ships, Part 7 - Machinery installation*, 1.12 shall be complied with.

4.2.5 Arrangements for oil fuel in periodically unattended machinery spaces

In addition to the requirements of 4.2.1 to 4.2.4, the oil fuel and lubricating oil systems in a periodically unattended machinery space shall comply with the following:

- .1 where daily service oil fuel tanks are filled automatically, or by remote control, means shall be provided to prevent overflow spillages. Other equipment which treats flammable liquids automatically (e.g. oil fuel purifiers) which, whenever practicable, shall be installed in a special space reserved for purifiers and their heaters, shall have arrangements to prevent overflow spillages; and
- .2 where daily service oil fuel tanks or settling tanks are fitted with heating arrangements, a high temperature alarm shall be provided if the flashpoint of the oil fuel can be exceeded.

Following additional requirements (IACS UR F35, Rev. 8) shall be applied:

Oil fuel in storage tanks should not to be heated to temperatures within 10°C below the flash point of the fuel oil, except that where oil fuel in service tanks, settling tanks and any other tanks in supply system is heated the following arrangements shall be provided:

- .1 the length of the vent pipes from such tanks and/or a cooling device is sufficient for cooling the vapours to below 60°C, or the outlet of the vent pipes is located 3m away from a source of ignition;
- .2 the vent pipes are fitted with flame screens;
- .3 there are no openings from the vapour space of the fuel tanks into machinery spaces (bolted manholes are acceptable);
- .4 enclosed spaces are not located directly over such fuel tanks, except for vented cofferdams ;
- .5 electrical equipment is not fitted in the vapour space of the tanks, unless it is certified to be intrinsically safe.

In addition, the requirements specified in other relevant Parts of the Rules for the classification of ships shall be complied with.

4.2.6 Flexible pipes

Flexible pipes, if used, shall be in accordance with other requirements specified in this part of the Rules for the classification of ships. In addition, the requirements specified in the *Rules for the classification of ships, Part 8 - Piping*, 1.3 shall be complied with.

4.3 ARRANGEMENTS FOR GASEOUS FUEL FOR DOMESTIC PURPOSES

4.3.1 Requirements of this head shall be applied to ships specified in 1.1.4 and also to: passenger ships not intended for international voyages, cargo ships of less than 500 gross tonnage intended for international voyages and cargo ships of 500 gross tonnage and upwards not intended for international voyages.

Gaseous fuel systems used for domestic purposes shall be approved by the *Register*. *Register* may accept the use of gaseous fuel for domestic purposes if gaseous fuel and all components of gaseous fuel arrangement (gas cylinders, gaseous fuel consumers, etc.) comply with recognized standards.

The use of gaseous fuel for domestic purposes in passenger ships and oil tankers shall be subject to the special consideration by the *Register*.

4.3.2 Gaseous fuel may be used for galley ranges, rapid water-heaters and provision refrigerators consuming not more than 1 kg of gas per hour.

4.3.3 Gaseous fuel consumers shall be fitted with automatic shutdown valve for stopping flow of gas in the event of burners flame failure.

For rapid water-heaters pilot flame shall be provided in addition.

4.3.4 Enclosed spaces intended for gas-cylinders store-room shall be efficiently ventilated. Store-room shall be located on the weather deck and have direct access from the weather deck. Access door shall be opened outwards and shall be fitted with lock and a conspicuous warning signs: "Danger-Explosion"; "No smoking".

4.3.5 Location for the storage of gas cylinders on the open deck (not more than two cylinders) shall be so chosen as to preclude mechanical damage of the cylinders and shall be at a distance of not less than 2 m from the accommodation spaces and control stations and shall not be contiguous with store-rooms for flammable liquids. Such a location shall be at a safe distance from the life-saving equipment also.

The cylinders shall be protected from the direct sun-light and from the access of the unauthorized persons thereto by the grating walls and door. In the close vicinity of the cylinders corresponding warning signs shall be exhibited (see 4.3.4).

The depth of a recess into a deck structure, used for the exclusive storage of gas cylinders, shall be not greater than 1 m (see *MSC.1/Circ.1276/Rev.1*). See also *IACS UI SC214*.

Galleys provided with gas-fired equipment shall not be located adjacent to store-rooms for flammable liquids and combustible materials.

4.3.6 Electric equipment located in store-room for gas cylinders shall comply with the requirements specified in the *Rules for the classification of ships, Part 12 – Electrical Equipment*, Section 19.

4.3.7 Stowage of gas cylinders shall comply with the following requirements:

- .1 cylinders shall be stowed in upright position with stop valves on top and secured with straps or similar quick release arrangements;
- .2 pressure reducing valve shall be provided between gas cylinder and piping;
- .3 where stowage of more than two gas cylinders is provided, a manifold with only one pressure reduction valve may be fitted. Copper pipes shall be used for connection between gas cylinders and the manifold.
- .4 shut-off valve or cock shall be fitted between each cylinder and the manifold. Warning sign prohibiting use of more than one cylinder at the same time shall be provided in close vicinity.

4.3.8 Enclosed spaces in which gaseous fuel consumers are installed shall comply with following:

- .1 the space shall not be located below the lowest open deck;
- .2 rapid water-heaters shall be provided with separate flue-gas discharge ducts.

4.3.9 Seamless-steel or copper pipes shall be used for gas-distribution piping. Steel pipes shall be protected against corrosion.

4.3.10 The wall thickness of pipes shall comply with the requirements prescribed in the *Rules for the classification of ships, Part 8 – Piping*, 1.3.

4.3.11 Distribution piping between cylinders and gaseous fuel consumers shall be led on weather deck and protected from mechanical damage.

4.3.12 Piping joints shall be of the welded type. Threaded joints or flange joints may be used only for control-measuring instruments, fittings and gaseous fuel consumers.

4.3.13 A shut-off valve or cock shall be fitted on distribution piping which shall be operated from outside the cylinder store-room. The shut-off valve or cock shall have indication for open and closed position.

4.3.14 Where provision is made for more than one gaseous fuel consumer, distribution piping for each consumer shall be fitted with shut-off valve or cock with indication for open and closed position. If such valves or cocks are located in the store-room, arrangements shall be provided to operate them from outside the store-room.

In latter case no shut-off valve or cock on manifold is required (see 4.3.13).

4.3.15 Pressure reducing valve setting shall not be higher than 5 kPa.

4.3.16 A safety valve with a setting pressure of less than 7 kPa shall be provided with gas outlet leading to a safe place on the open deck and fitted close-after to the pressure reducing valve. The safety valve need not be provided if the reducing valve is so designed that gas flow to the low pressure side is avoided in the case of failure or break of membrane.

4.3.17 Piping fittings shall be made of bronze, brass or other non-sparking corrosion-resistant material.

4.3.18 Pipeline from gas cylinder to pressure reducing valves shall be tested:

- .1 in a workshop, by hydraulic pressure of 2.5 MPa.
- .2 after installation on board, by air pressure of 1.7 MPa.

Pipelines from pressure reducing valve to gaseous fuel consumers shall be tested for tightness by air pressure of 0.02 MPa, after installation on board.

4.3.19 Galley flue gas ducts from gas-fired equipment, when passing through and/or being contiguous with accommodation spaces, service spaces and control stations, shall comply with the requirements for construction and fire insulation as required for exhaust ducts from galley ranges and shall be provided with automatic fire damper close to the boundaries penetrated (see *MSC/Circ.1276/Rev.1*).

4.3.20 Except wooden chopping board, no combustible materials shall be used in galleys provided with gas-fired equipment.

4.3.21 The relaxation of application of the requirements of 4.3.5 in ships of restricted service, other than ships specified in 4.3.22, is subject to special consideration by the *Register* in each particular case.

4.3.22 For ships of less than 500 gross tonnage, not engaged neither in international navigation nor on domestic line service, navigating only in summer period (April 1st to October 31st) in navigation area (6), 7 or 8, having gas-cylinders store-room located on sun deck above accommodations (e.g. salon, cabins), in case that additional safety measures are provided, the *Register* may waive the requirement for distance of not less than 2 m between gas-cylinders store-room and the accommodation spaces below, and approve location of gas-cylinders store-room above accommodation.

Required additional safety measures are:

- .1 passenger access to sun deck shall be prohibited; and
- .2 "No smoking" signs shall be provided at sun deck; and
- .3 gas-cylinders store-room boundaries, including weakened top boundary, shall be of approved design (drawing showing details shall be submitted for approval); and
- .4 gas-cylinders store-room floor deck shall be "A-60" insulated from the accommodation rooms below; and
- .5 not more than 2 gas cylinders for domestic use (cylinders for industrial use are not permitted) could be kept aboard (in gas-cylinders store-room); and
- .6 gas-cylinders store-room shall be located at least 3 m away from ventilation inlets/outlets and sources of heat; and
- .7 gas-cylinders store-room shall be located at least 3 m away from life rafts and life-boats.

4.4 MISCELLANEOUS ITEMS OF IGNITION SOURCES AND IGNITABILITY

4.4.1 Electric radiators

4.4.1.1 Electric radiators, if used, shall be fixed in position and so constructed as to reduce fire risks to a minimum. No such radiators shall be fitted with an element so exposed that clothing, curtains, or other similar materials can be scorched or set on fire by heat from the element.

4.4.1.2 Electric heating shall comply with the requirements specified in the *Rules for the classification of ships, Part 12 – Electrical Equipment*, 15.1 and 15.2.

4.4.1.3 Steam and electric radiators shall be fixed in a position at a distance of not less than 50 mm from bulkheads or linings. If the bulkheads and linings are of combustible material, the portions located against the heating elements shall be screened with heat deflectors of non-combustible material, otherwise the heating elements shall be at a distance of not less than 150 mm from the bulkheads and linings made of combustible materials.

4.4.2 Waste receptacles

Waste receptacles shall be constructed of non-combustible materials with no openings in the sides or bottom. See *IACS UI SC166 Rev.1*.

4.4.3 Insulation surfaces protected against oil penetration

In spaces where penetration of oil products is possible, the surface of insulation shall be impervious to oil or oil vapours.

4.4.4 Primary deck coverings

Primary deck coverings, if applied within accommodation and service spaces and control stations, shall be of approved material which will not readily ignite or give rise to smoke and toxic or explosive hazards at elevated temperatures, this being determined in accordance with the FTP Code.

In passenger ships, primary deck coverings on cabin balconies shall not give rise to smoke, toxic or explosive hazards at elevated temperatures, this being determined in accordance with the FTP Code.

4.5 CARGO AREAS OF TANKERS

4.5.1 Separation of cargo oil tanks

See *IACS UI SC54 Rev.3*.

4.5.1.1 Cargo pump-rooms, cargo tanks, slop tanks and cofferdams shall be positioned forward of machinery spaces. However, oil fuel bunker tanks need not be forward of machinery spaces. Cargo tanks and slop tanks shall be isolated from machinery spaces by cofferdams, cargo pump-rooms, oil bunker tanks or ballast tanks.

Pump-rooms containing pumps and their accessories for ballasting those spaces situated adjacent to cargo tanks and slop tanks and pumps for oil fuel transfer shall be

considered as equivalent to a cargo pump-room within the context of this Section provided that such pump-rooms have the same safety standard as that required for cargo pump-rooms. Pump-rooms intended solely for ballast or oil fuel transfer, however, need not comply with the requirements of head 10.9. The lower portion of the pump-room may be recessed into machinery spaces of category A to accommodate pumps, provided that the deck head of the recess is in general not more than one third of the moulded depth above the keel, except that in the case of ships of not more than 25,000 tonnes deadweight, where it can be demonstrated that for reasons of access and satisfactory piping arrangements this is impracticable, the *Register* may permit a recess in excess of such height, but not exceeding one half of the moulded depth above the keel. See *IACS UI SC188 Rev.3* and *IACS UI SC211/Corr.1*. See also *MSC/Circ.1037*.

4.5.1.2 Main cargo control stations, control stations, accommodation and service spaces (excluding isolated cargo handling gear lockers) shall be positioned aft of cargo tanks, slop tanks, and spaces which isolate cargo or slop tanks from machinery spaces, but not necessarily aft of the oil fuel bunker tanks and ballast tanks, and shall be arranged in such a way that a single failure of a deck or bulkhead shall not permit the entry of gas or fumes from the cargo tanks into main cargo control stations, control stations, or accommodation and service spaces. A recess provided in accordance with 4.5.1.1 need not be taken into account when the position of these spaces is being determined. See *IACS UI SC201 Rev.1 Corr.1*.

4.5.1.3 However, where deemed necessary, the *Register* may permit main cargo control stations, control stations, accommodation and service spaces forward of the cargo tanks, slop tanks and spaces which isolate cargo and slop tanks from machinery spaces, but not necessarily forward of oil fuel bunker tanks or ballast tanks.

Machinery spaces, other than those of category A, may be permitted forward of the cargo tanks and slop tanks provided they are isolated from the cargo tanks and slop tanks by cofferdams, cargo pump-rooms, oil fuel bunker tanks or ballast tanks, and have at least one portable fire extinguisher. In cases where they contain internal combustion machinery, one approved foam-type extinguisher of at least 45 l capacity or equivalent shall be arranged in addition to portable fire extinguishers. If operation of a semi-portable fire extinguisher is impracticable, this fire extinguisher may be replaced by two additional portable fire extinguishers.

Main cargo control stations, control stations and accommodation and service spaces shall be arranged in such a way that a single failure of a deck or bulkhead shall not permit the entry of gas or fumes from the cargo tanks into such spaces.

In addition, where deemed necessary for the safety or navigation of the ship, the *Register* may permit machinery spaces containing internal combustion machinery not being main propulsion machinery having an output greater than 375 kW to be located forward of the cargo area provided the arrangements are in accordance with the provisions of this head. See *IACS UI SC201 Rev.1 Corr.1*.

4.5.1.4 In combination carriers only:

- .1 The slop tanks shall be surrounded by cofferdams except where the boundaries of the slop tanks are part of the hull, main cargo deck, cargo pump-room bulkhead or

oil fuel bunker tank. These cofferdams shall not be open to a double bottom, pipe tunnel, pump-room or other enclosed space, nor shall they be used for cargo or ballast and shall not be connected to piping systems serving oil cargo or ballast. Means shall be provided for filling the cofferdams with water and for draining them. Where the boundary of a slop tank is part of the cargo pump-room bulkhead, the pump-room shall not be open to the double bottom, pipe tunnel or other enclosed space; however, openings provided with gastight bolted covers may be permitted;

- .2 Means shall be provided for isolating the piping connecting the pump-room with the slop tanks referred to in 4.5.1.4.1. The means of isolation shall consist of a valve followed by a spectacle flange or a spool piece with appropriate blank flanges. This arrangement shall be located adjacent to the slop tanks, but where this is unreasonable or impracticable, it may be located within the pump-room directly after the piping penetrates the bulkhead. A separate permanently installed pumping and piping arrangement incorporating a manifold, provided with a shut-off valve and a blank flange, shall be provided for discharging the contents of the slop tanks directly to the open deck for disposal to shore reception facilities when the ship is in the dry cargo mode. When the transfer system is used for slop transfer in the dry cargo mode, it shall have no connection to other systems. Separation from other systems by means of removal of spool pieces may be accepted;
- .3 Hatches and tank cleaning openings to slop tanks shall only be permitted on the open deck and shall be fitted with closing arrangements. Except where they consist of bolted plates with bolts at watertight spacing, these closing arrangements shall be provided with locking arrangements under the control of the responsible ship's officer;
- .4 Where cargo wing tanks are provided, cargo oil lines below deck shall be installed inside these tanks. However, the *Register* may permit cargo oil lines to be placed in special ducts provided these are capable of being adequately cleaned and ventilated to the satisfaction of the *Register*. Where cargo wing tanks are not provided, cargo oil lines below deck shall be placed in special ducts.
- .5 Cargo spaces and any enclosed spaces adjacent to cargo spaces shall be capable of being mechanically ventilated. The mechanical ventilation may be provided by portable fans.
- .6 An approved fixed gas warning system capable of monitoring flammable vapours

shall be provided in pipe tunnels and cofferdams, as referred to in paragraph .1, adjacent to slop tanks. Suitable arrangements shall be made to facilitate measurement of flammable vapours in cargo tanks and all other spaces within the cargo area. Such measurements shall be made possible from the weather deck or other easily accessible positions.

- .7 The arrangements for isolating slop tanks containing oil or oil residues from other cargo tanks shall consist of blank flanges which will remain in position at all times when cargoes other than liquid cargoes referred to in 9.2.4.1.2 are carried.
- .8 An instruction manual shall be kept onboard describing all essential procedures for conversion from oil to dry cargo service and vice versa including the carriage of slop on dry cargo voyages.

4.5.1.5 Where the fitting of a navigation position above the cargo area is shown to be necessary, it shall be for navigation purposes only and it shall be separated from the cargo tank deck by means of an open space with a height of at least 2 m. The fire protection requirements for such a navigation position shall be those required for control stations, as specified in 9.2.4.2 and other provisions for tankers, as applicable.

4.5.1.6 Means shall be provided to keep deck spills away from the accommodation and service areas. This may be accomplished by provision of a permanent continuous coaming of a height of at least 300 mm, extending from side to side. Special consideration shall be given to the arrangements associated with stern loading.

4.5.1.7 Prohibition of carriage in fore peak tanks of oil or other liquid substances which are flammable (IACS UR F33)

On ships of 400 GT and above, compartments forward of the collision bulkhead shall not be arranged for the carriage of oil or other liquid substances which are flammable.

4.5.2 Restriction on boundary openings

4.5.2.1 Except as permitted in 4.5.2.2, access doors, air inlets and openings to accommodation spaces, service spaces, control stations and machinery spaces shall not face the cargo area. They shall be located on the transverse bulkhead not facing the cargo area or on the outboard side of the superstructure or deckhouse at a distance of at least 4% of the length of the ship, but not less than 3 m from the end of the superstructure or deckhouse facing the cargo area. This distance need not exceed 5 m. See *IACS UI SC120, Rev.2, Corr.2*. See also *MSC.1/Circ.1459*.

4.5.2.2 The *Register* may permit access doors in boundary bulkheads facing the cargo area or within the 5 m limits specified in 4.5.2.1, to main cargo control stations and to such service spaces used as provision rooms, store-rooms and lockers, provided they do not give access directly or indirectly to any other space containing or providing for accommodation, control stations or service spaces such as galleys, pantries or workshops, or similar spaces containing sources of vapour ignition. The boundary of such a space shall be insulated to “A-

60” class standard, with the exception of the boundary facing the cargo area. Bolted plates for the removal of machinery may be fitted within the limits specified in 4.5.2.1. Wheelhouse doors and windows may be located within the limits specified in 4.5.2.1 so long as they are designed to ensure that the wheelhouse can be made rapidly and efficiently gastight and vapourtight. See *IACS UI SC55 Rev.2* and *IACS UI SC120, Rev.2, Corr.2*. See also *MSC.1/Circ.1459*.

4.5.2.3 Windows and sidescuttles facing the cargo area and on the sides of the superstructures and deckhouses within the limits specified in 4.5.2.1 shall be of the fixed (non-opening) type. Such windows and sidescuttles, except wheelhouse windows, shall be constructed to “A-60” class standard except that “A-0” class standard is acceptable for windows and sidescuttles outside the limit specified in 9.2.4.2.5.

4.5.2.4 Where there is permanent access from a pipe tunnel to the main pump-room, a watertight door shall be fitted complying with the requirements of the *Rules for the classification of ships, Part 3 – Hull equipment, 7.12* and, in addition, with the following:

- .1 in addition to the bridge operation, the watertight door shall be capable of being manually closed from outside the main pump-room entrance; and,
- .2 the watertight door shall be kept closed during normal operations of the ship except when access to the pipe tunnel is required.

See also 4.5.2.7.

4.5.2.5 Permanent approved gastight lighting enclosures for illuminating cargo pump-rooms may be permitted in bulkheads and decks separating cargo pump-rooms and other spaces provided they are of adequate strength and the integrity and gastightness of the bulkhead or deck is maintained.

4.5.2.6 The arrangement of ventilation inlets and outlets and other deckhouse and superstructure boundary space openings shall be such as to complement the provisions of 4.5.3 and 11.6. Such vents, especially for machinery spaces, shall be situated as far aft as practicable. Due consideration in this regard shall be given when the ship is equipped to load or discharge at the stern. Sources of ignition such as electrical equipment shall be so arranged as to avoid an explosion hazard.

4.5.2.7 If, owing to the design of a ship, it is impossible in practice, or unreasonable, to fulfil the requirements relating to the location of access doors, air inlets or other openings in superstructures and/or deckhouses, the *Register* may adopt alternative provisions provided that, as a consequence of doing so, no ignition source is located in the hazardous areas defined in publication IEC 60092-502, except for electrical installations that have the required protection and have been certified as safe under that standard. See *MSC.1/Circ.1459*.

4.5.2.8 Safety aspects of double bottoms and duct keels under cargo oil tanks (IACS UR F26, Rev. 3)

For all ships, irrespective of navigation area, pipe ducts in the double bottom shall comply with the following requirements:

- .1 They should not communicate with the engine room.

- .2 Provision shall be made for at least two exits to the open deck arranged at a maximum distance from each other. One of these exits fitted with a watertight closure may lead to the cargo pump room.
- .3 In the duct, provision shall be made for adequate mechanical ventilation.

4.5.2.9 Cargo openings in the bottoms of topside tanks of ships carrying alternatively oil and dry cargoes (grain, etc.) (IACS UR F27)

On ships carrying alternatively oil having a flash point not exceeding 60°C (closed cup test) or dry cargoes, openings which may be used for cargo operations are not permitted in bulkheads and decks separating oil cargo spaces from other spaces not designed and equipped for the carriage of oil cargoes unless alternative approved means are provided to ensure equivalent integrity.

4.5.3 Cargo tank venting

4.5.3.1 General requirements

The venting systems of cargo tanks shall be entirely distinct from the air pipes of the other compartments of the ship. The arrangements and position of openings in the cargo tank deck from which emission of flammable vapours can occur shall be such as to minimize the possibility of flammable vapours being admitted to enclosed spaces containing a source of ignition, or collecting in the vicinity of deck machinery and equipment which may constitute an ignition hazard. In accordance with this general principle, the criteria in 4.5.3.2 to 4.5.3.5 and 11.6 will apply.

4.5.3.2 Venting arrangements

4.5.3.2.1 The venting arrangements in each cargo tank may be independent or combined with other cargo tanks and may be incorporated into the inert gas piping.

4.5.3.2.2 Where the arrangements are combined with other cargo tanks, either stop valves or other acceptable means shall be provided to isolate each cargo tank. Where stop valves are fitted, they shall be provided with locking arrangements which shall be under the control of the responsible ship's officer. There shall be a clear visual indication of the operational status of the valves or other acceptable means. Where tanks have been isolated, it shall be ensured that relevant isolating valves are opened before cargo loading or ballasting or discharging of those tanks is commenced.

Any isolation must continue to permit the flow caused by thermal variations in a cargo tank in accordance with 11.6.1.1.

Any isolation shall also continue to permit the passage of large volumes of vapour, air or inert gas mixtures during cargo loading and ballasting, or during discharging in accordance with 11.6.1.2.

See *IACS UI SC140, Rev.3*.

4.5.3.2.3 If cargo loading and ballasting or discharging of a cargo tank or cargo tank group which is isolated from a common venting system is intended, that cargo tank or cargo tank group shall be fitted with a means for over-pressure or under-pressure protection as required in 11.6.3.2.

4.5.3.2.4 The venting arrangements shall be connected to the top of each cargo tank and shall be self-draining to the cargo tanks under all normal conditions of trim and list of the ship. Where it may not be possible to provide self-draining lines, permanent arrangements shall be provided to drain the vent lines to a cargo tank.

4.5.3.3 Safety devices in venting systems

The venting system shall be provided with devices to prevent the passage of flame into the cargo tanks. The design, testing and locating of these devices shall comply with the requirements established by the *Register* based on the guidelines developed by IMO and adopted by *Register*, see *Revised standards for the design, testing and locating of devices to prevent the passage of flame into cargo tanks in tankers (MSC/Circ.677, as amended)* and *Revised factors to be taken into consideration when designing cargo tank venting and gas-freeing arrangements (MSC/Circ.731)*.

Ullage openings shall not be used for pressure equalization. They shall be provided with self-closing and tightly sealing covers. Flame arresters and screens are not permitted in these openings. See *IACS UI SC173*.

4.5.3.4 Vent outlets for cargo handling and ballasting

4.5.3.4.1 Vent outlets for cargo loading, discharging and ballasting required by 11.6.1.2 shall:

- .1(1) permit the free flow of vapour mixtures; or
- .1(2) permit the throttling of the discharge of the vapour mixtures to achieve a velocity of not less than 30 m/s;
- .2 be so arranged that the vapour mixture is discharged vertically upwards;
- .3 where the method is by free flow of vapour mixtures, be such that the outlet shall be not less than 6 m above the cargo tank deck or fore and aft gangway if situated within 4 m of the gangway and located not less than 10 m measured horizontally from the nearest air intakes and openings to enclosed spaces containing a source of ignition and from deck machinery, which may include anchor windlass and chain locker openings, and equipment which may constitute an ignition hazard; (see *IACS UI SC 70, Rev.4, Corr.1*) and
- .4 where the method is by high-velocity discharge, be located at a height not less than 2 m above the cargo tank deck and not less than 10 m measured horizontally from the nearest air intakes and openings to enclosed spaces containing a source of ignition and from deck machinery, which may include anchor windlass and chain locker openings, and equipment which may constitute an ignition hazard. These outlets shall be provided with high-velocity devices of an approved type.

See *IACS UI SC 57, Rev.2*. See also *MSC.I/Circ.1459*.

4.5.3.4.2 The arrangements for the venting of vapours displaced from the cargo tanks during loading and ballasting shall comply with 4.5.3 and 11.6 and shall consist of either

one or more mast risers, or a number of high-velocity vents. The inert gas supply main may be used for such venting.

4.5.3.5 Isolation of slop tanks in combination carriers

4.5.3.5.1 In combination carriers, the arrangements for isolating slop tanks containing oil or oil residues from other cargo tanks shall consist of blank flanges which will remain in position at all times when cargoes other than liquid cargoes (see 3.1.2.48) are carried.

4.5.4 Ventilation

4.5.4.1 Ventilation systems in cargo pump-rooms

Cargo pump-rooms shall be mechanically ventilated and discharges from the exhaust fans shall be led to a safe place on the open deck. The ventilation of these rooms shall have sufficient capacity to minimize the possibility of accumulation of flammable vapours. The number of air changes shall be at least 20 per hour, based upon the gross volume of the space. The air ducts shall be arranged so that all of the space is effectively ventilated. The ventilation shall be of the suction type using fans of the non-sparking type.

See also 4.5.4.3.

4.5.4.2 Ventilation systems in combination carriers

In combination carriers, cargo spaces and any enclosed spaces adjacent to cargo spaces shall be capable of being mechanically ventilated. The mechanical ventilation may be provided by portable fans. An approved fixed gas warning system capable of monitoring flammable vapours shall be provided in cargo pump-rooms, pipe ducts and cofferdams, as referred to in 4.5.1.4, adjacent to slop tanks. Suitable arrangements shall be made to facilitate measurement of flammable vapours in all other spaces within the cargo area. Such measurements shall be made possible from the open deck or easily accessible positions.

4.5.4.3 Pump room ventilation (IACS UR F21)

With the following arrangement of exhaust trunking there should be 20 air changes per hour on the total volume of the pump room:

- .1 In the pump room bilges just above the transverse floor plates on bottom longitudinals, so that air can flow over the top from adjacent spaces.
- .2 An emergency intake located about 2 m above the pump room lower grating. This emergency intake would be used when the lower intakes are sealed off due to flooding in the bilges. The emergency intake should have a damper fitted which is capable of being opened or closed from the exposed main deck and lower grating level.
- .3 The foregoing exhaust system is in association with open grating floor plates to allow the free flow of air.
- .4 Arrangements involving a specific ratio of areas of upper emergency and lower main ventilator openings, which can be shown to result in at least the required 20 air changes per hour through the lower inlets, can be adopted without the use of damp-

ers. When the lower access inlets are closed then at least 15 air changes per hour should be obtained through the upper inlets.

4.5.5 Inert gas systems

4.5.5.1 Application

4.5.5.1.1 For tankers of 20,000 tonnes deadweight and upwards constructed on or after 1 July 2002 but before 1 January 2016, the protection of the cargo tanks shall be achieved by a fixed inert gas system in accordance with the requirements of the Fire Safety Systems Code, as adopted by resolution MSC.98(73), except that the *Register* may accept other equivalent systems or arrangements, as described in 4.5.5.4.

4.5.5.1.2 For tankers of 8,000 tonnes deadweight and upwards constructed on or after 1 January 2016 when carrying cargoes described in 1.1.13.1 or 1.1.13.2, the protection of the cargo tanks shall be achieved by a fixed inert gas system in accordance with the requirements of Section 24, except that the *Register* may accept other equivalent systems or arrangements, as described in 4.5.5.4.

4.5.5.1.3 Tankers operating with a cargo tank cleaning procedure using crude oil washing shall be fitted with an inert gas system complying with the Section 24 and with fixed tank washing machines. However, inert gas systems fitted on tankers constructed on or after 1 July 2002 but before 1 January 2016 shall comply with the Fire Safety Systems Code, as adopted by resolution MSC.98(73).

4.5.5.1.4 Tankers required to be fitted with inert gas systems shall comply with the following provisions:

- .1 double hull spaces shall be fitted with suitable connections for the supply of inert gas.
See *IACS UI SC272*. See *MSC.1/Circ.1555*;
- .2 where hull spaces are connected to a permanently fitted inert gas distribution system, means shall be provided to prevent hydrocarbon gases from the cargo tanks entering the double hull spaces through the system; and
- .3 where such spaces are not permanently connected to an inert gas distribution system, appropriate means shall be provided to allow connection to the inert gas main.

4.5.5.2 Inert gas systems of chemical tankers

4.5.5.2.1 The requirements for inert gas systems contained in the Section 24 need not be applied to chemical tankers constructed before 1 January 2016, including those constructed before 1 July 2012:

- .1 when carrying cargoes described in 1.1.13.1, provided that they comply with the requirements for inert gas systems on chemical tankers established by the Register, based on the guidelines developed by the IMO, see *Regulation for inert gas systems on chemical tankers*, adopted by the IMO by resolution *A.567(14)*, and Corr.1.; or

- .2 when carrying flammable cargoes other than crude oil or petroleum products such as cargoes listed in Chapters 17 and 18 of the International Bulk Chemical Code, provided that the capacity of tanks used for their carriage does not exceed 3,000 m³ and the individual nozzle capacities of tank washing machines do not exceed 17.5 m³/h and the total combined throughput from the number of machines in use in a cargo tank at any one time does not exceed 110 m³/h.

4.5.5.3 General requirements for inert gas systems

4.5.5.3.1 The inert gas system shall be capable of inerting, purging and gas-freeing empty tanks and maintaining the atmosphere in cargo tanks with the required oxygen content.

4.5.5.3.2 Tankers fitted with a fixed inert gas system shall be provided with a closed ullage system.

4.5.5.4 Requirements for equivalent systems

4.5.5.4.1 The *Register* may, after having given consideration to the ship's arrangement and equipment, accept other fixed installations, in accordance with SOLAS, Regulation I/5 and 4.5.5.4.3.

4.5.5.4.2 For tankers of 8,000 tonnes deadweight and upwards but less than 20,000 tonnes deadweight constructed on or after 1 January 2016, in lieu of fixed installations as required by 4.5.5.4.1, the *Register* may accept other equivalent arrangements or means of protection in accordance with SOLAS, Regulation I/5 and 4.5.5.4.3.

4.5.5.4.3 Equivalent systems or arrangements shall:

- .1 be capable of preventing dangerous accumulations of explosive mixtures in intact cargo tanks during normal service throughout the ballast voyage and necessary in-tank operations; and
- .2 be so designed as to minimize the risk of ignition from the generation of static electricity by the system itself.

4.5.6 Inerting, purging and gas-freeing

4.5.6.1 Arrangements for purging and/or gas-freeing shall be such as to minimize the hazards due to dispersal of flammable vapours in the atmosphere and to flammable mixtures in a cargo tank.

4.5.6.2 The procedure for cargo tank purging and/or gas-freeing shall be carried out in accordance with 16.3.2.

4.5.6.3 The arrangements for inerting, purging or gas-freeing of empty tanks as required in 4.5.5.3.1 shall be to the satisfaction of the *Register* and shall be such that the accumulation of hydrocarbon vapours in pockets formed by the internal structural members in a tank is minimized and that:

- .1 on individual cargo tanks, the gas outlet pipe, if fitted, shall be positioned as far as practicable from the inert gas/air inlet and in accordance with 4.5.3 and 11.6. The inlet of such outlet pipes may be located ei-

ther at deck level or at not more than 1 m above the bottom of the tank;

- .2 the cross-sectional area of such gas outlet pipe referred to in 4.5.6.3.1 shall be such that an exit velocity of at least 20 m/s can be maintained when any three tanks are being simultaneously supplied with inert gas. Their outlets shall extend not less than 2 m above deck level; and
- .3 each gas outlet referred to in 4.5.6.3.2 shall be fitted with suitable blanking arrangements.

See *IACS UI SC58 Rev.2*.

4.5.7 Gas measurement and detection

4.5.7.1 Portable instrument

Tankers shall be equipped with at least one portable instrument for measuring oxygen and one for measuring flammable vapour concentrations, together with a sufficient set of spares. Suitable means shall be provided for the calibration of such instruments. See *IACS UI SC149 Rev.2*. See also *MSC.1/Circ.1456 1456 and MSC.1/Circ.1581*.

In addition, portable instruments for measuring oxygen and flammable vapour concentrations on oil tankers shall be in compliance with following requirements (IACS UR F7 Rev. 3, Corr.1):

1. Every oil tanker is to be provided with at least two portable gas detectors capable of measuring flammable vapour concentrations in air (% LEL) and at least two portable O₂ analysers. Alternatively, at least two gas detectors, each capable of measuring both oxygen and flammable vapour concentrations in air (% LEL), are to be provided.
2. In addition, for tankers fitted with inert gas systems, at least two portable gas detectors are to be capable of measuring concentrations of flammable vapours in inerted atmosphere (% gas by volume).

4.5.7.2 Arrangements for gas measurement in double-hull spaces and double-bottom spaces

4.5.7.2.1 Suitable portable instruments for measuring oxygen and flammable vapour concentrations in double-hull spaces and double-bottom spaces shall be provided. In selecting these instruments, due attention shall be given to their use in combination with the fixed gas sampling line systems referred to in 4.5.7.2.2.

4.5.7.2.2 Where the atmosphere in double-hull spaces cannot be reliably measured using flexible gas sampling hoses, such spaces shall be fitted with permanent gas sampling lines. The configuration of gas sampling lines shall be adapted to the design of such spaces.

4.5.7.2.3 The materials of construction and dimensions of gas sampling lines shall be such as to prevent restriction. Where plastic materials are used, they shall be electrically conductive.

4.5.7.3 Arrangements for fixed hydrocarbon gas detection systems in double hull and double-bottom spaces of oil tankers

4.5.7.3.1 In addition to the requirements in 4.5.7.1 and 4.5.7.2, oil tankers of 20,000 tonnes deadweight and above shall be provided with a fixed hydrocarbon gas detection system complying with the Section 24 for measuring hydrocarbon gas concentrations in all ballast tanks and void spaces of double-hull and double-bottom spaces adjacent to the cargo tanks, including the forepeak tank and any other tanks and spaces under the bulkhead deck adjacent to cargo tanks.

See *MSC.1/Circ.1527*. See also *IACS Rec. No.123*, *IACS UI SC268*, *IACS UI SC272* and *Rec. No.131, Rev.1*.

4.5.7.3.2 Oil tankers provided with constant operative inerting systems for such spaces need not be equipped with fixed hydrocarbon gas detection equipment.

See *IACS Rec. No. 131, Rev.1*.

4.5.7.3.3 Notwithstanding the above, cargo pump-rooms subject to the provisions of 4.5.10 need not comply with the requirements of this item.

4.5.7.4 Installation requirements for analysing units for continuous monitoring of flammable vapours (IACS UR F43 Rev. 2)

This requirements applies to gas analysing units of the sampling type located outside gas dangerous zones and fitted on board oil/chemical tankers.

Gas analysing units with non-explosion proof measuring equipment may be located in areas outside cargo areas, e.g. in cargo control room, navigation bridge or engine room when mounted on the forward bulkhead provided the following requirements are observed:

- .1 Sampling lines shall not run through gas safe spaces, except where permitted under 4.5.7.4.5.
- .2 The gas sampling pipes shall be equipped with flame arresters. Sample gas is to be led to the atmosphere with outlets arranged in a safe location.
- .3 Bulkhead penetrations of sample pipes between safe and dangerous areas shall be of approved type and have same fire integrity as the division penetrated. A manual isolating valve shall be fitted in each of the sampling lines at the bulkhead on the gas safe side.
- .4 The gas detection equipment including sample piping, sample pumps, solenoids, analysing units etc. shall be located in a reasonably gas tight enclosure (e.g. a fully enclosed steel cabinet with a gasketed door) which is to be monitored by its own sampling point. At gas concentrations above 30% LFL inside the enclosure the entire gas analysing unit is to be automatically shut down.
- .5 Where the enclosure cannot be arranged directly on the bulkhead, sample pipes shall be of steel or other equivalent material and without detachable connections, ex-

cept for the connection points for isolating valves at the bulkhead and analysing units, and are to be routed on their shortest ways.

4.5.8 Air supply to double-hull spaces and double-bottom spaces

4.5.8.1 Double-hull spaces and double-bottom spaces shall be fitted with suitable connections for the supply of air.

4.5.9 Protection of cargo area

4.5.9.1 Drip pans for collecting cargo residues in cargo lines and hoses shall be provided in the area of pipe and hose connections under the manifold area. Cargo hoses and tank washing hoses shall have electrical continuity over their entire lengths, including couplings and flanges (except shore connections), and shall be earthed for removal of electrostatic charges.

4.5.9.2 Bow and stern loading and unloading arrangements on oil tankers (IACS UR F16 Rev.1)

Where a cargo hose connection is arranged outside the cargo tank area, the pipe leading to such connections is to be provided with means of segregation such as a spectacle flange, removable spool piece or equivalent (see *MSC/Circ. 474*) located within the cargo area. The space within 3 m of the manifold is to be considered as a dangerous area with regard to electrical or incendive equipment.

4.5.9.3 Fore peak ballast system on oil tankers (IACS UR F44 Rev.2)

The fore peak tank can be ballasted with the system serving other ballast tanks within the cargo area, provided:

- .1 The fore peak tank is considered as a hazardous area;
- .2 The vent pipe openings are located on open deck at an appropriate distance from sources of ignition. In this respect, the hazardous zones distances are to be defined in accordance to *IEC 60092-502: Electrical installations in ships - Tankers - Special features*;
- .3 Means are provided, on the open deck, to allow measurement of flammable gas concentrations within the fore peak tank by a suitable portable instrument;
- .4 The sounding arrangement to the fore peak tank is direct from open deck;
- .5 The access to the fore peak tank is direct from open deck. Alternatively, indirect access from the open deck to the fore peak tank through an enclosed space may be accepted provided that:
 - .5.1 In case the enclosed space is separated from the cargo tanks by cofferdams, the access is through a gas tight bolted manhole located in the enclosed space and a warning sign is to be provided at the manhole stating that the fore peak tank may only be opened after:
 - it has been proven to be gas free; or

any electrical equipment which is not certified safe in the enclosed space is isolated.

- 5.2 In case the enclosed space has a common boundary with the cargo tanks and is therefore a hazardous area, the enclosed space can be well ventilated.

In respect to all paragraphs of this unified requirement, the hazardous area classification is to be defined in accordance to *IEC 60092-502: Electrical installations in ships - Tankers - Special features*.

4.5.10 Protection of cargo pump-rooms

4.5.10.1 In tankers:

- .1 cargo pumps, ballast pumps and stripping pumps, installed in cargo pump-rooms and driven by shafts passing through pump-room bulkheads shall be fitted with temperature sensing devices for bulkhead shaft glands, bearings and pump casings. A continuous audible and visual alarm signal shall be automatically effected in the cargo control room or the pump control station;
- .2 lighting in cargo pump-rooms, except emergency lighting, shall be interlocked with ventilation such that the ventilation shall be in operation when switching on the lighting. Failure of the ventilation system shall not cause the lighting to go out (see *MSC/Circ.1037*);
- .3 a system for continuous monitoring of the concentration of hydrocarbon gases shall be fitted. Sampling points or detector heads shall be located in suitable positions in order that potentially dangerous leakages are readily detected. When the hydrocarbon gas concentration reaches a preset level, which shall not be higher than 10% of the lower flammable limit, a continuous audible and visual alarm signal shall be automatically effected in the pump-room, engine control room, cargo control room and navigation bridge to alert personnel to the potential hazard, see *IACS UI SC172 Rev.1*; and
- .4 all pump-rooms shall be provided with bilge level monitoring devices together with appropriately located alarms.

See *MSC/Circ.1037*.

4.5.10.2 See 1.1.13.7.

4.5.10.3 Cargo pump-rooms shall be arranged within separate spaces bounded with gastight bulkheads and decks constructed of steel, and may not give direct access to other spaces except as permitted in 4.5.2.4.

4.5.10.4 Gland seals in pump room bulkheads (IACS UR F13 Rev.1)

Where drive shafts pass through pump room bulkhead or deck plating, gastight glands are to be fitted.

The glands are to be efficiently lubricated from outside the pump room. The seal parts of the glands are to be of material that will not initiate sparks. The glands are to be

constructed and fitted in accordance with the relative Rules for the classification of ships for fittings attached to watertight bulkheads, and if a bellows piece is incorporated in the design, it should be pressure tested before fitting.

4.5.10.5 Bulkheads and decks separating cargo pump-rooms and machinery spaces of category A may be penetrated by shaft glands, electric cables and similar penetrations, provided that gastight seals with efficient lubrication or other means of ensuring the permanence of the gas seal, approved by the *Register*, are fitted in way of the bulkhead or deck.

4.5.11 Miscellaneous items

4.5.11.1 Access and control hatches, tank cleaning openings and other similar openings to cargo tanks and slop tanks shall only be permitted on the weather deck and shall be fitted with closing arrangements approved by the *Register*.

4.5.11.2 Access to fuel oil double bottom tanks situated immediately below the cargo tanks shall not be located in cargo tanks and machinery spaces.

4.5.11.3 Pipe tunnels passing through double hull and double bottom spaces shall be provided with not less than two separate access openings fitted on opposite ends of tunnel, at distances not exceeding 60 m, and leading to the open deck. The *Register* may accept pipe tunnel openings leading to the cargo pump-room, pump-room or void spaces in the cargo area provided they are fitted with means of closure approved by the *Register* (see 4.5.2.4).

Pipe tunnel shall not communicate with machinery spaces.

4.5.11.4 Dimensions and structure of pipe tunnels shall be such as to ensure their complete inspection and repair of piping and removal of an injured person.

4.5.11.5 Pipe tunnels shall be adequately ventilated and shall comply with the requirements specified in 4.5.10.1.2 and 4.5.10.1.3.

Where an enclosed pipe trunk is situated within the cargo tanks deck area, the requirements as specified in *MSC/Circ.1276/Rev.1* shall be complied with.

4.5.11.6 Arrangements for ballasting permanent ballast tanks adjacent to cargo tanks shall be located in the cargo area and shall be separate of piping systems serving spaces forward and aft of the cofferdams.

4.5.11.7 Tankers required to be fitted with inert gas system (see 4.5.5) shall be provided with suitable arrangements for inerting double hull and double bottom spaces and cofferdams, when necessary. The application of the requirements of sub-items 4.5.11.7 to 4.5.11.13 is subject to special consideration by the *Register* in each particular case.

4.5.11.8 The arrangements for inerting of spaces referred to in 4.5.11.7 may be through portable connections to the inert gas system for cargo tanks or by fixed piping connections. Where necessary fixed purge pipes arranged such as to take into account the configuration of these spaces shall be fitted (see *MSC/Circ. 730*).

4.5.11.9 If fixed piping is used the arrangements for inerting shall include a separate deck water seal and a non-return valve in order to prevent hydrocarbon gases from cargo tanks

entering the double hull, double bottom and cofferdams through the system.

Where such spaces are not permanently connected to the inert gas system, appropriate means shall be provided to allow connection to the inert gas main.

4.5.11.10 The double hull, double bottom and cofferdams may be inerted either at all times when empty, or only if hydrocarbon gases are detected indicating leakage between cargo tanks and such spaces in which case the fixed piping system shall be considered necessary.

4.5.11.11 Double hull, double bottom and, where appropriate, cofferdams shall be fitted with suitable connections for the supply of air.

4.5.11.12 The ventilation arrangements shall be capable of gasfreeing:

- .1 inerted spaces; or
- .2 spaces containing cargo vapours from leakages of cargo or cargo vapour; and maintaining adequate ventilation continuously during entry of personnel.

4.5.11.13 Alternative methods of ventilation may include use of portable gas-freeing fans or inert gas blowers and water ballast line or purge pipes (see *MSC/Circ. 730*).

4.6 HOT WORK, GAS WELDING EQUIPMENT AND GAS CYLINDERS ROOMS

4.6.1 Hot work shall be considered any work requiring the use of electric arc or gas welding equipment, cutting burner equipment or other forms of naked flame, as well as heating or spark generating tools, regardless of where it is carried out on board a ship.

4.6.2 Performing of any hot work operation shall be in accordance with relevant principles included in the fire safety operational booklet (see 16.2) and, when undertaken outside the designated space, shall be controlled under the Safety Management System (SMS) on board through adequate guidance-permit to work system.

4.6.3 Whenever possible, a space such as engine room workshop or a separate room shall be designated for hot work.

4.6.4 The designated space shall be assessed for possible risks and provided with adequate conditions under which hot work may be carried in that space (ventilation, fire protection and fire-extinguishing arrangements, etc.) to the satisfaction of the *Register*.

4.6.5 The requirements of this Section for gas welding equipment and gas cylinders rooms shall apply to the fixed centralised plant for oxyacetylene welding on board consisting of a gas cylinders, piping and distribution stations, where the total number of acetylene and oxygen cylinders exceeds four.

4.6.6 The gas cylinders room containing acetylene and oxygen cylinders, where distribution headers, non-return and stop valves, pressure reducing devices and outlets of supply lines to distribution stations may also be installed, shall comply with the following requirements:

- .1 Cylinders shall be stowed in upright position and rested on stands having sockets. Straps or similar arrangements shall be fitted for securing and quick release of the cylinders;
- .2 The gas cylinders room shall be adequately insulated and ventilated, as appropriate, so that the temperature inside does not exceed 45°C. When the total number of gas cylinders, including possible spare cylinders which are not connected to the system, does not exceed 8, acetylene and oxygen cylinders may be installed in the same enclosed space. Otherwise acetylene and oxygen cylinders shall be located in separate enclosed spaces. The gas cylinders room shall be located on the weather deck and provided with direct access from the weather deck. Access door shall open outwards and shall be fitted with lock and the conspicuous warning signs: "Danger-Explosion"; "No-Smoking". No common boundaries with the accommodation spaces and control stations shall be permitted. The gas cylinders room shall not be used for other services on board;
- .3 Storage of gas cylinders on the weather deck is subject to special consideration by the *Register* in each particular case. Location shall be so chosen as to preclude mechanical damage of the cylinders and shall be at a distance not less than 2 m from the accommodation spaces and control stations and shall be not contiguous with store rooms for flammable liquids. Such a location shall be at a safe distance from the life-saving equipment also. The cylinders shall be protected from the access of the unauthorized persons thereto and from the direct sun-light. In the close vicinity of the cylinders relevant warning signs shall be exhibited (see paragraph .2 above).

4.6.7 No more than two distribution stations are normally permitted.

Distribution stations which may be adequately protected areas or cabinets equipped with stop valves, pressure regulating devices, pressure gauges, non-return valves and oxygen as well as acetylene hose connections for the welding torch, shall be located in the designated space such as engine room workshop or in the separate enclosed space, in a well-ventilated position and protected against possible mechanical damage.

5 FIRE GROWTH POTENTIAL

5.1 GENERAL REQUIREMENTS

5.1.1 The purpose of this Section is to limit the fire growth potential in every space of the ship. For this purpose, the following functional requirements shall be met:

- .1 means of control for the air supply to the space shall be provided;
- .2 means of control for flammable liquids in the space shall be provided; and
- .3 the use of combustible materials shall be restricted.

5.2 CONTROL OF AIR SUPPLY AND FLAMMABLE LIQUID TO THE SPACE

5.2.1 Closing appliances and stopping devices of ventilation

5.2.1.1 The main inlets and outlets of all ventilation systems shall be capable of being closed from outside the spaces being ventilated. The means of closing shall be easily accessible as well as prominently and permanently marked and shall indicate whether the shut-off is open or closed. See *IACS UI SC100 Rev.2/Corr.1* and *IACS UI SC240/Corr.1*. See also *MSC.1/Circ.1434*.

5.2.1.2 Power ventilation of accommodation spaces, service spaces, cargo spaces, control stations and machinery spaces shall be capable of being stopped from an easily accessible position outside the space being served. This position shall not be readily cut off in the event of a fire in the spaces served. See *IACS UI SC148 Rev.2*. See *MSC.1/Circ.1555*.

5.2.1.3 In passenger ships carrying more than 36 passengers, power ventilation, except machinery space and cargo space ventilation and any alternative system which may be required under 8.2, shall be fitted with controls so grouped that all fans may be stopped from either of two separate positions which shall be situated as far apart as practicable. Fans serving power ventilation systems to cargo spaces shall be capable of being stopped from a safe position outside such spaces. See *IACS UI SC148 Rev.2*. See *MSC.1/Circ.1555*.

5.2.2 Means of control in machinery spaces

5.2.2.1 Means of control shall be provided for opening and closure of skylights, closure of openings in funnels which normally allow exhaust ventilation and closure of ventilator dampers.

5.2.2.2 Means of control shall be provided for stopping ventilating fans. Controls provided for the power ventilation serving machinery spaces shall be grouped so as to be operable from two positions, one of which shall be outside such spaces. The means provided for stopping the power ventilation of the machinery spaces shall be entirely separate from the means provided for stopping ventilation of other spaces.

5.2.2.3 Means of control shall be provided for stopping forced and induced draught fans, oil fuel transfer pumps, oil fuel unit pumps, lubricating oil service pumps, thermal oil circulating pumps and oil separators (purifiers). However, 5.2.2.4 and 5.2.2.5 need not apply to oily water separators.

Following additional requirement (IACS UR F35, Rev. 8) applies:

Controls required by this Section shall also be provided from the compartment itself.

5.2.2.4 The controls required in 5.2.2.1 to 5.2.2.3 and in 4.2.2.3.4 shall be located outside the space concerned so they will not be cut off in the event of fire in the space they serve.

5.2.2.5 In passenger ships, the controls required in 5.2.2.1 to 5.2.2.4 and in 8.3.3 and 9.5.2.3 and the controls for any required fire-extinguishing system shall be situated at one control position or grouped in as few positions as possible to the satisfaction of the *Register*. Such positions shall have a safe access from the open deck.

5.2.3 Additional requirements for means of control in periodically unattended machinery spaces

5.2.3.1 For periodically unattended machinery spaces, the *Register* shall give special consideration to maintaining the fire integrity of the machinery spaces, the location and centralization of the fire-extinguishing system controls, the required shutdown arrangements (e.g. ventilation, fuel pumps, etc.) and that additional fire-extinguishing appliances and other fire-fighting equipment and breathing apparatus may be required.

5.2.3.2 In passenger ships, these requirements shall be at least equivalent to those of machinery spaces normally attended.

5.3 FIRE PROTECTION MATERIALS

See *IACS UI SC126 Rev.2 Corr.1*.

5.3.1 Use of non-combustible materials

5.3.1.1 Insulating materials

Insulating materials shall be non-combustible, except in cargo spaces, mail rooms, baggage rooms and refrigerated compartments of service spaces. Vapour barriers and adhesives used in conjunction with insulation, as well as the insulation of pipe fittings for cold service systems, need not be of non-combustible materials, but they shall be kept to the minimum quantity practicable and their exposed surfaces shall have low flame-spread characteristics. See *IACS UI SC102 Rev.1*.

5.3.1.2 Ceilings and linings

5.3.1.2.1 In passenger ships, except in cargo spaces, all linings, grounds, draught stops and ceilings shall be of non-combustible material except in mail rooms, baggage rooms, saunas or refrigerated compartments of service spaces (see Annex 1).

5.3.1.2.2 In cargo ships of 500 gross tonnage and upwards, all linings, ceilings, draught stops and their associated

grounds shall be of non-combustible materials in the following spaces:

- .1 in accommodation and service spaces and control stations for ships where method IC is specified as referred to in 9.2.3.1; and
- .2 in corridors and stairway enclosures serving accommodation and service spaces and control stations for ships where methods IIC or IIIC are specified as referred to in 9.2.3.1.

5.3.1.3 Partial bulkheads and decks on passenger ships

5.3.1.3.1 Partial bulkheads or decks used to subdivide a space for utility or artistic treatment shall be of non-combustible materials.

5.3.1.3.2 Linings, ceilings and partial bulkheads or decks used to screen or to separate adjacent cabin balconies shall be of non-combustible materials. See 5.3.4.1.

Additional requirements

5.3.1.4 Neither combustible nor oil-absorbing materials shall be used as flooring, bulkhead lining, ceiling or decks in the propulsion machinery control room, machinery spaces, shaft tunnel or rooms where oil tanks are located.

5.3.1.5 In cargo ships of less than 500 gross tonnage but not less than 300, in corridors and stairways enclosures serving accommodation and service spaces and control stations, all linings, ceilings, draught stops and their associated grounds shall be of non-combustible materials.

5.3.1.6 The galley floor shall be lined with ceramic tiles or other equivalent non-combustible materials.

5.3.2 Use of combustible materials

5.3.2.1 General

5.3.2.1.1 In passenger ships, "A", "B" or "C" class divisions in accommodation and service spaces and cabin balconies which are faced with combustible materials, facings, mouldings, decorations and veneers shall comply with the provisions of 5.3.2.2 to 5.3.2.4 and Section 6. However, traditional wooden benches and wooden linings on bulkheads and ceilings are permitted in saunas and such materials need not be subject to the calculations prescribed in 5.3.2.2 and 5.3.2.3. However, the provisions of 5.3.2.3 need not be applied to cabin balconies.

5.3.2.1.2 In cargo ships of 500 gross tonnage and upwards, non-combustible bulkheads, ceilings and linings fitted in accommodation and service spaces may be faced with combustible materials, facings, mouldings, decorations and veneers provided such spaces are bounded by non-combustible bulkheads, ceilings and linings in accordance with the provisions of 5.3.2.2 to 5.3.2.4 and Section 6.

5.3.2.2 Maximum calorific value of combustible materials

Combustible materials used on the surfaces and linings specified in 5.3.2.1 shall have a calorific value (determined in accordance with recognised standards, such as recommendations published by the *International Organization*

for Standardization, in particular ISO/DIS 1716, Reaction to fire tests for building and transport products – Determination of the heat of combustion) not exceeding 45 MJ/m² of the area for the thickness used. The requirements of this item are not applicable to the surfaces of furniture fixed to linings or bulkheads.

5.3.2.3 Total volume of combustible materials

Where combustible materials are used in accordance with 5.3.2.1, they shall comply with the following requirements:

- .1 The total volume of combustible facings, mouldings, decorations and veneers in accommodation and service spaces shall not exceed a volume equivalent to 2.5 mm veneer on the combined area of the walls and ceiling linings. Furniture fixed to linings, bulkheads or decks need not be included in the calculation of the total volume of combustible materials; and
- .2 in the case of ships fitted with an automatic sprinkler system complying with the provisions of the Section 24, the above volume may include some combustible material used for erection of "C" class divisions.
- .3 The total mass of combustible materials used for the construction of bulkheads, linings, ceilings and their associated grounds and furniture in accommodation and service spaces, other than saunas, and control stations, on all types of ships, except cargo ships of less than 500 gross tonnage, and spaces where use of such materials is not prohibited, shall be not in excess of maximum values for the total mass of combustible materials per unit area prescribed in *MSC/Circ.1003*.

5.3.2.4 Low flame-spread characteristics of exposed surfaces

The following surfaces shall have low flame-spread characteristics in accordance with the Fire Test Procedures Code.

5.3.2.4.1 In passenger ships:

- .1 exposed surfaces in corridors and stairway enclosures and of bulkhead and ceiling linings in accommodation and service spaces (except saunas) and control stations;
- .2 surfaces and grounds in concealed or inaccessible spaces in accommodation and service spaces and control stations; and
- .3 exposed surfaces of cabin balconies, except for natural hard wood decking systems.

5.3.2.4.2 In cargo ships of 500 GT and upwards:

- .1 exposed surfaces in corridors and stairway enclosures and of ceilings in accommodation and service spaces (except saunas) and control stations; and

- .2 surfaces and grounds in concealed or inaccessible spaces in accommodation and service spaces and control stations.

5.3.3 Furniture in stairway enclosures of passenger ships

5.3.3.1 Furniture in stairway enclosures shall be limited to seating. It shall be fixed, limited to six seats on each deck in each stairway enclosure, be of restricted fire risk determined in accordance with the Fire Test Procedures Code, and shall not restrict the passenger escape route. The *Register* may permit additional seating in the main reception area within a stairway enclosure if it is fixed, non-combustible and does not restrict the passenger escape route. Furniture shall not be permitted in passenger and crew corridors forming escape routes in cabin areas.

In addition to the above, lockers of non-combustible material, providing storage for non-hazardous safety equipment required by these Sections, may be permitted. Drinking water dispensers and ice cube machines may be permitted in corridors provided they are fixed and do not restrict the width of the escape routes. This applies as well to decorative flower or plant arrangements, statues or other objects of art such as paintings and tapestries in corridors and stairways.

5.3.4 Furniture and furnishings on cabin balconies of passenger ships

5.3.4.1 On passenger ships, furniture and furnishings on cabin balconies shall comply with 3.1.2.40.1, 3.1.2.40.2, 3.1.2.40.3, 3.1.2.40.6 and 3.1.2.40.7 unless such balconies are protected by a fixed pressure water-spraying and fixed fire detection and fire alarm systems complying with 7.10 and 10.6.1.3.

5.4 STORE-ROOMS FOR FLAMMABLE LIQUIDS AND READILY COMBUSTIBLE MATERIALS

5.4.1 Flammable liquids and readily combustible materials shall be stowed in a separate and designated enclosed spaces.

5.4.2 Store-room for flammable liquids shall be, in general, located on the weather deck and have direct access from the weather deck.

Entrance door shall be opened outward and provided with a lock and conspicuous warning signs: "Flammable Liquids"; "No Smoking".

5.4.3 Store-room for readily combustible materials shall be, in general, not situated in common with accommodation and service spaces and control stations.

Access shall be provided from the weather deck directly or through a corridor or a stairway leading to this room. Entrance door shall be provided with a lock.

5.4.4 Store-room for stowage of cargo samples in tankers ($\leq 60^{\circ}\text{C}$) shall, in generally, be situated in the cargo area. For chemical tankers see the *Rules for the classification of ships, Part 27 – Chemical Tankers*, 16.5.

5.4.5 Paint stores shall be not situated in the cargo area of tankers ($\leq 60^{\circ}\text{C}$) and chemical tankers, see *IACS UI SC201 Rev.1 Corr.1*.

5.4.6 Location and arrangement of store-room designated for storage of fuel oil with a flash point of less than 43°C shall be subject to special consideration be the *Register* in each particular case.

The fuel oil shall be packaged in metal jerrycans having capacity of not exceeding 60 l and fitted with fixed tight closing lids.

For the requirements for helicopter refuelling facilities see Section 18.

5.4.7 Store-rooms for flammable liquids, except for store-room for stowage of cargo samples located in the cargo area, shall be mechanically ventilated with separate exhaust fan.

5.4.8 Fire-extinguishing arrangements in store-rooms for flammable liquids shall comply with the requirements as specified in Section 10.

5.4.9 Electric equipment located in store-room for flammable liquids shall comply with requirements specified in the *Rules for the classification of ships, Part 12 – Electrical Equipment*, 19.4.

6 SMOKE GENERATION POTENTIAL AND TOXICITY

6.1 GENERAL REQUIREMENTS

6.1.1 The purpose of this Section is to reduce the hazard to life from smoke and toxic products generated during a fire in spaces where persons normally work or live. For this purpose, the quantity of smoke and toxic products released from combustible materials, including surface finishes, during fire shall be limited.

6.2 PAINTS, VARNISHES AND OTHER FINISHES

See *IACS UI SC126 Rev.2 Corr.1* and *IACS UI SC127, Rev.2, Corr.1*.

6.2.1 Paints, varnishes and other finishes used on exposed interior surfaces shall not be capable of producing excessive quantities of smoke and toxic products, this being determined in accordance with the Fire Test Procedures Code.

6.2.2 On passenger ships, paints, varnishes and other finishes used on exposed surfaces of cabin balconies, excluding natural hard wood decking systems, shall not be capable of producing excessive quantities of smoke and toxic products, this being determined in accordance with the Fire Test Procedures Code.

6.3 PRIMARY DECK COVERINGS

6.3.1 Primary deck coverings, if applied within accommodation and service spaces and control stations, shall be of approved material which will not give rise to smoke or toxic or explosive hazards at elevated temperatures, this being determined in accordance with the Fire Test Procedures Code.

6.3.2 On passenger ships, primary deck coverings on cabin balconies shall not give rise to smoke, toxic or explosive hazards at elevated temperatures, this being determined in accordance with the Fire Test Procedures Code.

7 FIRE DETECTION AND ALARM

7.1 PURPOSE

7.1.1 The purpose of this Section is to detect a fire in the space of origin and to provide for alarm for safe escape and fire-fighting activity. For this purpose, the following functional requirements shall be met:

- .1 fixed fire detection and fire alarm system installations shall be suitable for the nature of the space, fire growth potential and potential generation of smoke and gases;
- .2 manually operated call points shall be placed effectively to ensure a readily accessible means of notification; and
- .3 fire patrols shall provide an effective means of detecting and locating fires and alerting the navigation bridge and fire teams.

7.2 GENERAL REQUIREMENTS

7.2.1 A fixed fire detection and fire alarm system shall be provided in accordance with the provisions of this Section.

7.2.2 A fixed fire detection and fire alarm system and a sample extraction smoke detection system required in this Section and other Sections in this Part of the Rules for the classification of ships shall be of an approved type and comply with the Section 24.

7.2.3 Where a fixed fire detection and fire alarm system is required for the protection of spaces other than those specified in 7.5.1, at least one detector complying with the Section 24 shall be installed in each such space.

7.2.4 A fixed fire detection and fire alarm system for passenger ships shall be capable of remotely and individually identifying each detector and manually operated call point.

7.3 INITIAL AND PERIODICAL TESTS

7.3.1 The function of fixed fire detection and fire alarm systems required by the relevant Sections of this Rules for the classification of ships shall be tested under varying conditions of ventilation after installation.

7.3.2 The function of fixed fire detection and fire alarm systems shall be periodically tested to the satisfaction of the *Register* by means of equipment producing hot air at the appropriate temperature, or smoke or aerosol particles having the appropriate range of density or particle size, or other phenomena associated with incipient fires to which the detector is designed to respond.

7.4 PROTECTION OF MACHINERY SPACES

See *IACS UI SCI29 Rev.2*.

7.4.1 Installation

A fixed fire detection and fire alarm system shall be installed in:

- .1 periodically unattended machinery spaces;
- .2 machinery spaces where:
 - .2.1 the installation of automatic and remote control systems and equipment has been approved in lieu of continuous manning of the space; and
 - .2.2 the main propulsion and associated machinery, including the main sources of electrical power, are provided with various degrees of automatic or remote control and are under continuous manned supervision from a control room; and
- .3 enclosed spaces containing incinerators.

7.4.2 Design

7.4.2.1 The fixed fire detection and fire alarm system required in 7.4.1.1 shall be so designed and the detectors so positioned as to detect rapidly the onset of fire in any part of those spaces and under any normal conditions of operation of the machinery and variations of ventilation as required by the possible range of ambient temperatures. Except in spaces of restricted height and where their use is specially appropriate, detection systems using only thermal detectors shall not be permitted.

The detection system shall initiate audible and visual alarms distinct in both respects from the alarms of any other system not indicating fire, in sufficient places to ensure that the alarms are heard and observed on the navigation bridge and by a responsible engineer officer. When the navigation bridge is unmanned, the alarm shall sound in a place where a responsible member of the crew is on duty.

7.5 PROTECTION OF ACCOMMODATION AND SERVICE SPACES AND CONTROL STATIONS

7.5.1 Smoke detectors in accommodation spaces

Smoke detectors shall be installed in all stairways, corridors and escape routes within accommodation spaces as provided in 7.5.2, 7.5.3 and 7.5.4. Consideration shall be given to the installation of special purpose smoke detectors within ventilation ducting (see *MSC/Circ.1035*).

7.5.2 Requirements for passenger ships carrying more than 36 passengers

A fixed fire detection and fire alarm system shall be so installed and arranged as to provide smoke detection in service spaces, control stations and accommodation spaces, including corridors, stairways and escape routes within accommodation spaces. Smoke detectors need not be fitted in private bathrooms and galleys. Spaces having little or no fire risk such as voids, public toilets, carbon dioxide rooms and similar spaces need not be fitted with a fixed fire detection and alarm system. Detectors fitted in cabins, when activated, shall also be capable of emitting, or cause to be emitted, an audible alarm within the space where they are located. See *IACS UI SCI30 Rev.2*.

7.5.3 Requirements for passenger ships carrying not more than 36 passengers

There shall be installed throughout each separate zone, whether vertical or horizontal, in all accommodation and service spaces and, where it is considered necessary by the *Register*, in control stations, except spaces which afford no substantial fire risk such as void spaces, sanitary spaces, etc., either:

- .1 a fixed fire detection and fire alarm system so installed and arranged as to detect the presence of fire in such spaces and providing smoke detection in corridors, stairways and escape routes within accommodation spaces. Detectors fitted in cabins, when activated, shall also be capable of emitting, or cause to be emitted, an audible alarm within the space where they are located; or
- .2 an automatic sprinkler, fire detection and fire alarm system of an approved type complying with the relevant requirements of the Section 24 and so installed and arranged as to protect such spaces and, in addition, a fixed fire detection and fire alarm system and so installed and arranged as to provide smoke detection in corridors, stairways and escape routes within accommodation spaces.

7.5.4 Protection of atriums in passenger ships

The entire main vertical zone containing the atrium shall be protected throughout with a smoke detection system.

7.5.5 Cargo ships

Accommodation and service spaces and control stations of cargo ships shall be protected by a fixed fire detection and fire alarm system and/or an automatic sprinkler, fire detection and fire alarm system as follows, depending on a protection method adopted in accordance with 9.2.3.1. See *MSC.1/Circ.1456*.

7.5.5.1 Method IC - A fixed fire detection and fire alarm system shall be so installed and arranged as to provide smoke detection in all corridors, stairways and escape routes within accommodation spaces.

7.5.5.2 Method IIC - An automatic sprinkler, fire detection and fire alarm system of an approved type complying with the relevant requirements of the Section 24 shall be so installed and arranged as to protect accommodation spaces, galleys and other service spaces, except spaces which afford no substantial fire risk such as void spaces, sanitary spaces, etc. In addition, a fixed fire detection and fire alarm system shall be so installed and arranged as to provide smoke detection in all corridors, stairways and escape routes within accommodation spaces.

7.5.5.3 Method IIIC - A fixed fire detection and fire alarm system shall be so installed and arranged as to detect the presence of fire in all accommodation spaces and service spaces, providing smoke detection in corridors, stairways and escape routes within accommodation spaces, except spaces which afford no substantial fire risk such as void spaces, sanitary spaces, etc. In addition, a fixed fire detection and fire

alarm system shall be so installed and arranged as to provide smoke detection in all corridors, stairways and escape routes within accommodation spaces. See *IACS UI SC160 Rev.1*.

7.6 PROTECTION OF CARGO SPACES IN PASSENGER SHIPS

7.6.1 A fixed fire detection and fire alarm system or a sample extraction smoke detection system shall be provided in any cargo space which, in the opinion of the *Register*, is not accessible, except where it is shown to the satisfaction of the *Register* that the ship is engaged on voyages of such short duration that it would be unreasonable to apply this requirement.

7.7 MANUALLY OPERATED CALL POINTS

7.7.1 Manually operated call points complying with the Section 24 shall be installed throughout the accommodation spaces, service spaces and control stations. One manually operated call point shall be located at each exit. Manually operated call points shall be readily accessible in the corridors of each deck such that no part of the corridor is more than 20 m from a manually operated call point. See *IACS UI SC241*.

7.8 FIRE PATROLS IN PASSENGER SHIPS**7.8.1 Fire patrols**

For ships carrying more than 36 passengers, an efficient patrol system shall be maintained so that an outbreak of fire may be promptly detected. Each member of the fire patrol shall be trained to be familiar with the arrangements of the ship as well as the location and operation of any equipment he may be called upon to use.

7.8.2 Inspection hatches

The construction of ceilings and bulkheads shall be such that it will be possible, without impairing the efficiency of the fire protection, for the fire patrols to detect any smoke originating in concealed and inaccessible places, except where in the opinion of the *Register* there is no risk of fire originating in such places.

7.8.3 Two-way portable radiotelephone apparatus

Each member of the fire patrol shall be provided with a two-way portable radiotelephone apparatus.

7.9 FIRE ALARM SIGNALLING SYSTEMS IN PASSENGER SHIPS

Refer to the *Code on alerts and indicators 2009 (resolution A.1021(26), as may be amended)*.

7.9.1 Passenger ships shall at all times when at sea, or in port (except when out of service), be so manned or equipped as to ensure that any initial fire alarm is immediately received by a responsible member of the crew.

7.9.2 The control panel of fixed fire detection and fire alarm systems shall be designed on the fail-safe principle (e.g. an open detector circuit shall cause an alarm condition).

7.9.3 Passenger ships carrying more than 36 passengers shall have the fire detection alarms for the systems required by 7.5.2 centralized in a continuously manned central control station. In addition, controls for remote closing of the fire doors and shutting down the ventilation fans shall be centralized in the same location. The ventilation fans shall be capable of reactivation by the crew at the continuously manned control station. The control panels in the central control station shall be capable of indicating open or closed positions of fire doors and closed or off status of the detectors, alarms and fans. The control panel shall be continuously powered and shall have an automatic change-over to standby power supply in case of loss of normal power supply. The control panel shall be powered from the main source of electrical power and the emergency source of electrical power defined by the *Rules for the classification of ships, Part 12 – Electrical Equipment*, Section 9 unless other arrangements are permitted by this Part of the Rules for the classification of ships, as applicable. See *IACS U1 SCI48 Rev.2*. See *MSC.1/Circ.1555*.

7.9.4 A special alarm, operated from the navigation bridge or fire control station, shall be fitted to summon the crew. This alarm may be part of the ship's general alarm system and shall be capable of being sounded independently of the alarm to the passenger spaces.

7.10 PROTECTION OF CABIN BALCONIES ON PASSENGER SHIPS

7.10.1 A fixed fire detection and fire alarm system complying with the provisions of the Section 24 shall be installed on cabin balconies of ships to which 5.3.4 applies, when furniture and furnishings on such balconies are not as defined in 3.1.2.40.1, 3.1.2.40.2, 3.1.2.40.3, 3.1.2.40.6 and 3.1.2.40.7. See *Guidelines for the approval of fixed pressure water-spraying and water-based fire-extinguishing systems for cabin balconies (MSC.1/Circ.1268)*.

8 CONTROL OF SMOKE SPREAD

8.1 GENERAL REQUIREMENTS

8.1.1 The purpose of this Section is to control the spread of smoke in order to minimize the hazards from smoke. For this purpose, means for controlling smoke in atriums, control stations, machinery spaces and concealed spaces shall be provided.

8.2 PROTECTION OF CONTROL STATIONS OUTSIDE MACHINERY SPACES

8.2.1 Practicable measures shall be taken for control stations outside machinery spaces in order to ensure that ventilation, visibility and freedom from smoke are maintained so that, in the event of fire, the machinery and equipment contained therein may be supervised and continue to function effectively. Alternative and separate means of air supply shall be provided and air inlets of the two sources of supply shall be so disposed that the risk of both inlets drawing in smoke simultaneously is minimized. At the discretion of the *Register*, such requirements need not apply to control stations situated on, and opening onto, an open deck or where local closing arrangements would be equally effective. The ventilation system serving safety centres may be derived from the ventilation system serving the navigation bridge, unless located in an adjacent main vertical zone.

See *IACS UI SC39 Rev.2*.

8.3 RELEASE OF SMOKE FROM MACHINERY SPACES

8.3.1 The provisions of this head shall apply to machinery spaces of category A and, where the *Register* considers it desirable, to other machinery spaces.

8.3.2 Suitable arrangements shall be made to permit the release of smoke, in the event of fire, from the space to be protected, subject to the provisions of 9.5.2.1 The normal ventilation systems may be acceptable for this purpose.

8.3.3 Means of control shall be provided for permitting the release of smoke and such controls shall be located outside the space concerned so that they will not be cut off in the event of fire in the space they serve.

8.3.4 In passenger ships, the controls required by 8.3.3 shall be situated at one control position or grouped in as few positions as possible to the satisfaction of the *Register*. Such positions shall have a safe access from the open deck.

8.4 DRAUGHT STOPS

8.4.1 Air spaces enclosed behind ceilings, panelling or linings shall be divided by close-fitting draught stops spaced not more than 14 m apart. In the vertical direction, such en-

closed air spaces, including those behind linings of stairways, trunks, etc., shall be closed at each deck.

8.5 SMOKE EXTRACTION SYSTEMS IN ATRIUMS OF PASSENGER SHIPS

8.5.1 Atriums shall be equipped with a smoke extraction system. The smoke extraction system shall be activated by the required smoke detection system and be capable of manual control. The fans shall be sized such that the entire volume within the space can be exhausted in 10 min or less.

For smoke management systems, if installed, see *MSC.1/Circ.1514*.

9 CONTAINMENT OF FIRE

9.1 GENERAL REQUIREMENTS

9.1.1 The purpose of this Section is to contain a fire in the space of origin. For this purpose, the following functional requirements shall be met:

- .1 the ship shall be subdivided by thermal and structural boundaries;
- .2 thermal insulation of boundaries shall have due regard to the fire risk of the space and adjacent spaces; and
- .3 the fire integrity of the divisions shall be maintained at openings and penetrations.

9.2 THERMAL AND STRUCTURAL BOUNDARIES

9.2.1 Thermal and structural subdivision

9.2.1.1 Ships of all types shall be subdivided into spaces by thermal and structural divisions having regard to the fire risks of the spaces. See *MSC.1/Circ.1555*.

9.2.2 Passenger ships

9.2.2.1 Main vertical zones and horizontal zones

See *IACS UI SC101 Rev.1*.

9.2.2.1.1 On ships carrying:

- .1 more than 36 passengers, the hull, superstructure and deckhouses shall be subdivided into main vertical zones by "A-60" class divisions. Steps and recesses shall be kept to a minimum, but where they are necessary they shall also be "A-60" class divisions. Where a category (5), (9) or (10) space defined in 9.2.2.3.2.2 is on one side or where fuel oil tanks are on both sides of the division the standard may be reduced to "A-0".
- .2 not more than 36 passengers, the hull, superstructure and deckhouses in way of accommodation and service spaces shall be subdivided into main vertical zones by "A" class divisions. These divisions shall have insulation values in accordance with tables in 9.2.2.4.

9.2.2.1.2 As far as practicable, the bulkheads forming the boundaries of the main vertical zones above the bulkhead deck shall be in line with watertight subdivision bulkheads situated immediately below the bulkhead deck. The length and width of main vertical zones may be extended to a maximum of 48 m in order to bring the ends of main vertical zones to coincide with watertight subdivision bulkheads or in order to accommodate a large public space extending for the whole length of the main vertical zone provided that the total area of the main vertical zone is not greater than 1,600 m² on any deck. The length or width of a main vertical zone is the maximum dis-

tance between the furthestmost points of the bulkheads bounding it.

9.2.2.1.3 Such bulkheads shall extend from deck to deck and to the shell or other boundaries.

9.2.2.1.4 Where a main vertical zone is subdivided by horizontal "A" class divisions into horizontal zones for the purpose of providing an appropriate barrier between a zone with sprinklers and a zone without sprinklers, the divisions shall extend between adjacent main vertical zone bulkheads and to the shell or exterior boundaries of the ship and shall be insulated in accordance with the fire insulation and integrity values given in table 9.4.

9.2.2.1.5 On ships designed for special purposes, such as automobile or railroad car ferries, where the provision of main vertical zone bulkheads would defeat the purpose for which the ship is intended, equivalent means for controlling and limiting a fire shall be substituted and specifically approved by the *Register*. See 24.23.

Service spaces and ship stores shall not be located on ro-ro decks unless protected in accordance with the applicable Sections.

However, in a ship with special category spaces, such spaces shall comply with the applicable provisions of Section 20 and, where such compliance would be inconsistent with other requirements for passenger ships specified in this Rules for the classification of ships, the requirements of Section 20 shall prevail.

9.2.2.2 Bulkheads within a main vertical zone

9.2.2.2.1 For ships carrying more than 36 passengers, bulkheads which are not required to be "A" class divisions shall be at least "B" class or "C" class divisions as prescribed in the tables in 9.2.2.3.

9.2.2.2.2 For ships carrying not more than 36 passengers, bulkheads within accommodation and service spaces which are not required to be "A" class divisions shall be at least "B" class or "C" class divisions as prescribed in the tables in 9.2.2.4. In addition, corridor bulkheads, where not required to be "A" class, shall be "B" class divisions which shall extend from deck to deck, except:

- .1 when continuous "B" class ceilings or linings are fitted on both sides of the bulkhead, the portion of the bulkhead behind the continuous ceiling or lining shall be of material which, in thickness and composition, is acceptable in the construction of "B" class divisions, but which shall be required to meet "B" class integrity standards only in so far as is reasonable and practicable in the opinion of the *Register*; and
- .2 in the case of a ship protected by an automatic sprinkler system complying with the provisions of the Section 24, the corridor bulkheads may terminate at a ceiling in the corridor provided such bulkheads and ceilings are of "B" class standard in compliance with 9.2.2.4. All doors and frames in such bulkheads shall be of non-combustible materials and shall have the

same fire integrity as the bulkhead in which they are fitted.

9.2.2.2.3 Bulkheads required to be “B” class divisions, except corridor bulkheads as prescribed in 9.2.2.2.2, shall extend from deck to deck and to the shell or other boundaries. However, where a continuous “B” class ceiling or lining is fitted on both sides of a bulkhead which is at least of the same fire resistance as the adjoining bulkhead, the bulkhead may terminate at the continuous ceiling or lining. See *IACS UI SC107 Rev.1*.

9.2.2.3 Fire integrity of bulkheads and decks in ships carrying more than 36 passengers

9.2.2.3.1 In addition to complying with the specific provisions for fire integrity of bulkheads and decks of passenger ships, the minimum fire integrity of all bulkheads and decks shall be as prescribed in tables 9.1 and 9.2. Where, due to any particular structural arrangements in the ship, difficulty is experienced in determining from the tables the minimum fire integrity value of any divisions, such values shall be determined to the satisfaction of the *Register*.

9.2.2.3.2 The following requirements shall govern application of the tables:

- .1 Table 9.1 shall apply to bulkheads not bounding either main vertical zones or horizontal zones. Table 9.2 shall apply to decks not forming steps in main vertical zones nor bounding horizontal zones.
- .2 For determining the appropriate fire integrity standards to be applied to boundaries between adjacent spaces, such spaces are classified according to their fire risk as shown in categories (1) to (14) below. Where the contents and use of a space are such that there is a doubt as to its classification for the purpose of this Section, or where it is possible to assign two or more classifications to a space, it shall be treated as a space within the relevant category having the most stringent boundary requirements. Smaller, enclosed rooms within a space that have less than 30% communicating openings to that space are considered separate spaces. The fire integrity of the boundary bulkheads and decks of such smaller rooms shall be as prescribed in tables 9.1 and 9.2. The title of each category is intended to be typical rather than restrictive. The number in parentheses preceding each category refers to the applicable column or row in the tables.
 - (1) Control stations:
 - Spaces containing emergency sources of power and lighting.
 - Wheelhouse and chartroom.
 - Spaces containing the ship’s radio equipment.
 - Fire control stations.
 - Control room for propulsion machinery when located outside the propulsion machinery space.
 - Spaces containing centralized fire alarm equipment.

Spaces containing centralized emergency public address system stations and equipment.

Safety center.

- (2) Stairways:
 - Interior stairways, lifts, totally enclosed emergency escape trunks and escalators (other than those wholly contained within the machinery spaces) for passengers and crew and enclosures thereto.
 - In this connection, a stairway which is enclosed at only one level shall be regarded as part of the space from which it is not separated by a fire door.
- (3) Corridors:
 - Passenger and crew corridors.
- (4) Evacuation stations and external escape routes:
 - Survival craft stowage area.
 - Open deck spaces and enclosed promenades forming lifeboat and liferaft embarkation and lowering stations.
 - Muster stations, internal and external.
 - External stairs and open decks used for escape routes.
 - The ship’s side to the waterline in the lightest seagoing condition, superstructure and deckhouse sides situated below and adjacent to the liferaft’s and evacuation slide’s embarkation areas.
- (5) Open deck spaces:
 - Open deck spaces and enclosed promenades clear of lifeboat and liferaft embarkation and lowering stations.
 - To be considered in this category, enclosed promenades shall have no significant fire risk, meaning that furnishings shall be restricted to deck furniture. In addition, such spaces shall be naturally ventilated by permanent openings.
 - Air spaces (the space outside superstructures and deckhouses).
- (6) Accommodation spaces of minor fire risk:
 - Cabins containing furniture and furnishings of restricted fire risk.
 - Offices and dispensaries containing furniture and furnishings of restricted fire risk.
 - Public spaces containing furniture and furnishings of restricted fire risk and having a deck area of less than 50 m².
- (7) Accommodation spaces of moderate fire risk:

- Spaces as in category (6) above but containing furniture and furnishings of other than restricted fire risk.
Public spaces containing furniture and furnishings of restricted fire risk and having a deck area of 50 m² or more.
Isolated lockers and small store-rooms in accommodation spaces having areas less than 4 m² (in which flammable liquids are not stowed).
Motion picture projection and film stowage rooms.
Diet kitchens (containing no open flame).
Cleaning gear lockers (in which flammable liquids are not stowed).
Laboratories (in which flammable liquids are not stowed).
Pharmacies.
Small drying rooms (having a deck area of 4m² or less).
Specie rooms.
Operating rooms.
See *IACS UI SCI167 Rev.1 Corr.1*.
- (8) Accommodation spaces of greater fire risk:
Public spaces containing furniture and furnishings of other than restricted fire risk and having a deck area of 50 m² or more.
Barber shops and beauty parlours.
Saunas
Sale shops
- (9) Sanitary and similar spaces:
Communal sanitary facilities, showers, baths, water closets, etc.
Small laundry rooms.
Indoor swimming pool areas.
Isolated pantries containing no cooking appliances in accommodation spaces. See *MSC.1/Circ.1634*.
(Private sanitary facilities shall be considered a portion of the space in which they are located).
- (10) Tanks, voids and auxiliary machinery spaces having little or no fire risk:
Water tanks forming part of the ship's structure.
Voids and cofferdams.
Auxiliary machinery spaces which do not contain machinery having a pressure lubrication system and where storage of combustibles is prohibited, such as:
ventilation and air-conditioning rooms; windlass room; steering gear room; stabilizer equipment room; electrical propulsion motor room; rooms containing section switchboards and purely electrical equipment other than oil-filled electrical transformers (above 10 kVA); shaft alleys and pipe tunnels; spaces for pumps and refrigeration machinery (not handling or using flammable liquids).
Closed trunks serving the spaces listed above.
Other closed trunks such as pipe and cable trunks.
See *MSC.1/Circ.1616 and IACS UI SC294*.
- (11) Auxiliary machinery spaces, cargo spaces, fuel oil tanks and other similar spaces of moderate fire risk:
Cargo holds, trunkways and hatchways.
Refrigerated chambers.
Oil fuel tanks (where installed in a separate space with no machinery).
Shaft alleys and pipe tunnels allowing storage of combustibles.
Auxiliary machinery spaces as in category (10) which contain machinery having a pressure lubrication system or where storage of combustibles is permitted.
Oil fuel filling stations.
Spaces containing oil-filled electrical transformers (above 10 kVA).
Spaces containing turbine and reciprocating steam engine driven auxiliary generators and small internal combustion engines of power output up to 110 kW driving generators, sprinkler, drencher or fire pumps, bilge pumps, etc.
Closed trunks serving the spaces listed above.
- (12) Machinery spaces and main galleys:
Main propulsion machinery rooms (other than electric propulsion motor rooms) and boiler rooms.
Auxiliary machinery spaces other than those in categories (10) and (11) which contain internal combustion machinery or other oil-burning, heating or pumping units.
Main galleys and annexes.
Trunks and casings to the spaces listed above.
- (13) Store-rooms, workshops, pantries, etc.:
Main pantries not annexed to galleys. See *MSC.1/Circ.1436*.
Main laundry.
Large drying rooms (having a deck area of more than 4 m²).
Miscellaneous stores.
Mail and baggage rooms.
Garbage rooms.
Workshops (not part of machinery spaces, galleys, etc.).
Lockers and store-rooms having areas greater than 4 m², other than those

- spaces that have provisions for the storage of flammable liquids.
- (14) Other spaces in which flammable liquids are stowed:
 - Paint lockers.
 - Store-rooms containing flammable liquids (including dyes, medicines, etc.).
 - Laboratories (in which flammable liquids are stowed).
- .3 Where a single value is shown for the fire integrity of a boundary between two spaces, that value shall apply in all cases.
- .4 Notwithstanding the provisions of 9.2.2.2, there are no special requirements for material or integrity of boundaries where only a dash appears in the tables.
- .5 The *Register* shall determine in respect of category (5) spaces whether the insulation values in table 9.1 shall apply to ends of deckhouses and superstructures, and whether the insulation values in table 9.2 shall apply to weather decks. In no case shall the requirements of category (5) of tables 9.1 or 9.2 necessitate enclosure of spaces which in the opinion of the *Register* need not be enclosed.

Table 9.1
Bulkheads not bounding either main vertical zones or horizontal zones

| Spaces | Space categ. | (1) | (2) | (3) | (4) | (5) | (6) | (7) | (8) | (9) | (10) | (11) | (12) | (13) | (14) |
|---|--------------|------------------|------------------|------|------|-----|---------------------|---------------------|---------------------|------------------|------------------|-------------------|-------------------|-------------------|-------------------|
| Control stations | (1) | B-0 ^a | A-0 | A-0 | A-0 | A-0 | A-60 | A-60 | A-60 | A-0 | A-0 | A-60 | A-60 | A-60 | A-60 |
| Stairways | (2) | | A-0 ^a | A-0 | A-0 | A-0 | A-0 | A-15 | A-15 | A-0 ^c | A-0 | A-15 | A-30 | A-15 | A-30 |
| Corridors | (3) | | | B-15 | A-60 | A-0 | B-15 | B-15 | B-15 | B-15 | A-0 | A-15 | A-30 | A-0 | A-30 |
| Evacuation stations and external escape routes | (4) | | | | | A-0 | A-60 ^{b,d} | A-60 ^{b,d} | A-60 ^{b,d} | A-0 ^d | A-0 | A-60 ^b | A-60 ^b | A-60 ^b | A-60 ^b |
| Open deck spaces | (5) | | | | | | A-0 | A-0 | A-0 | A-0 | A-0 | A-0 | A-0 | A-0 | A-0 |
| Accommodation spaces of minor fire risk | (6) | | | | | | B-0 | B-0 | B-0 | C | A-0 | A-0 | A-30 | A-0 | A-30 |
| Accommodation spaces of moderate fire risk | (7) | | | | | | | B-0 | B-0 | C | A-0 | A-15 | A-60 | A-15 | A-60 |
| Accommodation spaces of greater fire risk | (8) | | | | | | | | B-0 | C | A-0 | A-30 | A-60 | A-15 | A-60 |
| Sanitary and similar spaces | (9) | | | | | | | | | C | A-0 | A-0 | A-0 | A-0 | A-0 |
| Tanks, voids and auxiliary machinery spaces having little or no fire risk | (10) | | | | | | | | | | A-0 ^a | A-0 | A-0 | A-0 | A-0 |
| Auxiliary machinery spaces, cargo spaces, fuel oil tanks and other similar spaces of moderate fire risk | (11) | | | | | | | | | | | A-0 ^a | A-0 | A-0 | A-15 |
| Machinery spaces and main galleys | (12) | | | | | | | | | | | | A-0 ^a | A-0 | A-60 |
| Store-rooms, workshops, pantries, etc. | (13) | | | | | | | | | | | | | A-0 ^a | A-0 |
| Other spaces in which flammable liquids are stowed | (14) | | | | | | | | | | | | | | A-30 |

See notes following Table 9.2

Table 9.2
Decks not forming steps in main vertical zones nor bounding horizontal zones

| Spaces | above | Spaces categ. | (1) | (2) | (3) | (4) | (5) | (6) | (7) | (8) | (9) | (10) | (11) | (12) | (13) | (14) |
|---|-------|------------------|------|------|------------------|------|-----|------|------|------|-----|------------------|------------------|-------------------|------|------|
| | below | | | | | | | | | | | | | | | |
| Control stations | | (1) | A-30 | A-30 | A-15 | A-0 | A-0 | A-0 | A-15 | A-30 | A-0 | A-0 | A-0 | A-60 | A-0 | A-60 |
| Stairways | | (2) | A-0 | A-0 | A-0 | A-0 | A-0 | A-0 | A-0 | A-0 | A-0 | A-0 | A-0 | A-30 | A-0 | A-30 |
| Corridors | | (3) | A-15 | A-0 | A-0 ^a | A-60 | A-0 | A-0 | A-15 | A-15 | A-0 | A-0 | A-0 | A-30 | A-0 | A-30 |
| Evacuation stations and external escape routes | | (4) | A-0 | A-0 | A-0 | A-0 | – | A-0 | A-0 | A-0 | A-0 | A-0 | A-0 | A-0 | A-0 | A-0 |
| Open deck spaces | | (5) | A-0 | A-0 | A-0 | A-0 | – | A-0 | A-0 | A-0 | A-0 | A-0 | A-0 | A-0 | A-0 | A-0 |
| Accommodation spaces of minor fire risk | | (6) | A-60 | A-15 | A-0 | A-60 | A-0 | A-0 | A-0 | A-0 | A-0 | A-0 | A-0 | A-0 | A-0 | A-0 |
| Accommodation spaces of moderate fire risk | | (7) | A-60 | A-15 | A-15 | A-60 | A-0 | A-0 | A-15 | A-15 | A-0 | A-0 | A-0 | A-0 | A-0 | A-0 |
| Accommodation spaces of greater fire risk | | (8) | A-60 | A-15 | A-15 | A-60 | A-0 | A-15 | A-15 | A-30 | A-0 | A-0 | A-0 | A-0 | A-0 | A-0 |
| Sanitary and similar spaces | | (9) | A-0 | A-0 | A-0 | A-0 | A-0 | A-0 | A-0 | A-0 | A-0 | A-0 | A-0 | A-0 | A-0 | A-0 |
| Tanks, voids and auxiliary machinery spaces having little or no fire risk | | (10) | A-0 | A-0 | A-0 | A-0 | A-0 | A-0 | A-0 | A-0 | A-0 | A-0 ^a | A-0 | A-0 | A-0 | A-0 |
| Auxiliary machinery spaces, cargo spaces, fuel oil tanks and other similar spaces of moderate fire risk | | (11) | A-60 | A-60 | A-60 | A-60 | A-0 | A-0 | A-15 | A-30 | A-0 | A-0 | A-0 ^a | A-0 | A-0 | A-30 |
| Machinery spaces and main galleys | | (12) | A-60 | A-60 | A-60 | A-60 | A-0 | A-60 | A-60 | A-60 | A-0 | A-0 | A-30 | A-30 ^a | A-0 | A-60 |
| Store rooms, workshops, pantries, etc. | | (13) | A-60 | A-30 | A-15 | A-60 | A-0 | A-15 | A-30 | A-30 | A-0 | A-0 | A-0 | A-0 | A-0 | A-0 |
| Other spaces in which flammable liquids are stowed | | (14) | A-60 | A-60 | A-60 | A-60 | A-0 | A-30 | A-60 | A-60 | A-0 | A-0 | A-0 | A-0 | A-0 | A-0 |

Notes to be applied to Table 9.1 and Table 9.2, as appropriate

- a Where adjacent spaces are in the same numerical category and superscript “a” appears, a bulkhead or deck between such spaces need not be fitted if deemed unnecessary by the *Register*. For example, in category (12) a bulkhead need not be required between a galley and its annexed pantries provided the pantry bulkhead and decks maintain the integrity of the galley boundaries. No fire rating is required for those partitions separating the navigation bridge and the safety centre when the latter is within the navigation bridge. A bulkhead is, however, required between a galley and machinery space even though both spaces are in category (12).
- b The ship’s side, to the waterline in the lightest seagoing condition, superstructure and deckhouse sides situated below and adjacent to the liferafts and evacuation slides may be insulated to “A-30” standard.
- c Where public toilets are installed completely within the stairway enclosure, the public toilet bulkhead within the stairway enclosure may be of “B” class integrity.
- d Where spaces of category 6, 7, 8, and 9 are located completely within the outer perimeter of the assembly station, the bulkheads of these spaces are allowed to be of “B-0” class integrity. Control positions for audio, video and light installations may be considered as part of the muster station.

9.2.2.3.3 Continuous “B” class ceilings or linings, in association with the relevant decks or bulkheads, may be accepted as contributing, wholly or in part, to the required insulation and integrity of a division, providing that they are fire tested in accordance with the FTP Code.

9.2.2.3.4 Construction and arrangement of saunas

- .1 The perimeter of the sauna shall be of “A” class boundaries and may include changing rooms, showers and toilets. The sauna shall be insulated to “A-60” standard against other spaces except those inside of the perimeter and spaces of categories (5), (9) and (10).
- .2 Bathrooms with direct access to saunas may be considered as part of them. In such cases, the door between sauna and the bathroom need not comply with fire safety requirements.
- .3 The traditional wooden lining on the bulkheads and ceiling are permitted in the sauna. The ceiling above the oven shall be lined with a non-combustible plate with an air gap of at least 30 mm. The distance from the hot surfaces to combustible materials shall be at least 500 mm or the combustible materials shall be protected (e.g. non-combustible plate with an air gap of at least 30 mm).
- .4 The traditional wooden benches are permitted to be used in the sauna.
- .5 The sauna door shall open outwards by pushing.
- .6 Electrically heated ovens shall be provided with a timer.
- .7 Electrical equipment, cables and wiring in saunas shall comply with the requirements specified in the *Rules for the classification of ships, Part 12 – Electrical Equipment*, 15 and 16.8.

9.2.2.4 Fire integrity of bulkheads and decks in ships carrying not more than 36 passengers

9.2.2.4.1 In addition to complying with the specific provisions for fire integrity of bulkheads and decks of passenger ships, the minimum fire integrity of bulkheads and decks shall be as prescribed in tables 9.3 and 9.4.

9.2.2.4.2 The following requirements shall govern application of the tables:

- .1 Tables 9.3 and 9.4 shall apply respectively to the bulkheads and decks separating adjacent spaces.
- .2 For determining the appropriate fire integrity standards to be applied to divisions between adjacent spaces, such spaces are classified according to their fire risk as shown in categories (1) to (11) below. Where the contents and use of a space are such that there is a doubt as to its classification for the purpose of this Section, or where it is possible to assign two or more classifications to a space, it shall be treated

as a space within the relevant category having the most stringent boundary requirements. Smaller, enclosed rooms within a space that have less than 30% communicating openings to that space are considered separate spaces. The fire integrity of the boundary bulkheads and decks of such smaller rooms shall be as prescribed in tables 9.3 and 9.4. The title of each category is intended to be typical rather than restrictive. The number in parentheses preceding each category refers to the applicable column or row in the tables. See *MSC.1/Circ.1581*.

- (1) Control stations
 - Spaces containing emergency sources of power and lighting.
 - Wheelhouse and chartroom.
 - Space containing the ship’s radio equipment.
 - Fire control stations.
 - Control room for propulsion machinery when located outside the machinery space.
 - Spaces containing centralized fire alarm equipment.
- (2) Corridors:
 - Passenger and crew corridors and lobbies.
- (3) Accommodation spaces:
 - Spaces as defined in 3.1.2.1, excluding corridors and lobbies.
- (4) Stairways:
 - Interior stairways, lifts, totally enclosed emergency escape trunks and escalators (other than those wholly contained within the machinery spaces) and enclosures thereto.
 - In this connection, a stairway which is enclosed only at one level shall be regarded as a part of the space from which it is not separated by a fire door.
- (5) Service spaces (low fire risk):
 - Lockers and store-rooms not having provisions for the storage of flammable liquids and having areas of less than 4 m² and drying rooms and laundries.
 - See *IACS UI SC 167, Rev.1 Corr.1*
- (6) Machinery spaces of category A:
 - Spaces as defined in 3.1.2.31.
- (7) Other machinery spaces:
 - Electrical equipment rooms (see the *Rules for the classification of ships, Part 12 – Electrical Equipment*, 1.2.7), auto-telephone exchange and air-conditioning duct spaces.
 - Spaces as defined in 3.1.2.30, excluding machinery spaces of category A.
 - See *MSC.1/Circ.1616*.
 - See *IACS UI SC 294*.

- (8) Cargo spaces:
All spaces used for dry cargo and trunkways and hatchways to such spaces, other than special category spaces.
- (9) Service spaces (high fire risk):
Galleys, pantries containing cooking appliances, paint lockers, lockers and store-rooms having areas of 4 m² or more, spaces for the storage of flammable liquids, saunas and workshops other than those forming part of the machinery spaces. See *MSC.1/Circ.1436*.
- (10) Open decks:
Open deck spaces and enclosed promenades having little or no fire risk. Enclosed promenades shall have no significant fire risk, meaning that furnishing shall be restricted to deck furniture. In addition, such spaces shall be naturally ventilated by permanent openings.
Air spaces (the space outside super-structures and deckhouses).
- (11) Special category and ro-ro spaces:
- Spaces as defined in 3.1.2.46 and 3.1.2.41.
- .3 In determining the applicable fire integrity standard of a boundary between two spaces within a main vertical zone or horizontal zone which is not protected by an automatic sprinkler system complying with the provisions of the Section 24 or between such zones neither of which is so protected, the higher of the two values given in the tables shall apply.
- .4 In determining the applicable fire integrity standard of a boundary between two spaces within a main vertical zone or horizontal zone which is protected by an automatic sprinkler system complying with the provisions of the Section 24 or between such zones both of which are so protected, the lesser of the two values given in the tables shall apply. Where a zone with sprinklers and a zone without sprinklers meet within accommodation and service spaces, the higher of the two values given in the tables shall apply to the division between the zones.

Table 9.3
Fire integrity of bulkheads separating adjacent spaces

| Spaces | space categ. | (1) | (2) | (3) | (4) | (5) | (6) | (7) | (8) | (9) | (10) | (11) |
|-----------------------------------|--------------|------------------|----------------|------------------|--------------------------------------|--------------------------------------|------|------------------|------|--------------------------|--------|--------------------------|
| Control station | (1) | A-0 ^c | A-0 | A-60 | A-0 | A-15 | A-60 | A-15 | A-60 | A-60 | * | A-60 |
| Corridors | (2) | | C ^e | B-0 ^e | A-0 ^a B-0 ^e | B-0 ^e | A-60 | A-0 | A-0 | A-15 A-0 ^d | * | A-30 ^g |
| Accommodation spaces | (3) | | | C ^e | A-0 ^a B-0 ^e | B-0 ^e | A-60 | A-0 | A-0 | A-15 A-0 ^d | * | A-30 A-0 ^d |
| Stairways | (4) | | | | A-0 ^a B-0 ^e | A-0 ^a B-0 ^e | A-60 | A-0 | A-0 | A-15 A-0 ^d | * * | A-30 ^g |
| Service spaces (low risk) | (5) | | | | | C ^e | A-60 | A-0 | A-0 | A-0 | * | A-0 |
| Machinery spaces of category A | (6) | | | | | | * | A-0 | A-0 | A-60 | * | A-60 |
| Other machinery spaces | (7) | | | | | | | A-0 ^b | A-0 | A-0 | * | A-0 |
| Cargo spaces | (8) | | | | | | | | * | A-0 | * | A-0 |
| Service spaces (high risk) | (9) | | | | | | | | | A-0 ^b | * | A-30 |
| Open decks | (10) | | | | | | | | | | | A-0 |
| Special category and ro-ro spaces | (11) | | | | | | | | | | | A-30 ^g |

See notes following Table 9.4

Table 9.4
Fire integrity of decks separating adjacent spaces

| Spaces | above | Space categ. | (1) | (2) | (3) | (4) | (5) | (6) | (7) | (8) | (9) | (10) | (11) |
|-----------------------------------|-------|-----------------|------|--------------------------|--------------------------|--------------------------|------|-------------------|-------------------|------|------|------|--------------------------|
| | below | | | | | | | | | | | | |
| Control stations | | (1) | A-0 | A-0 | A-0 | A-0 | A-0 | A-60 | A-0 | A-0 | A-0 | * | A-60 ^g |
| Corridors | | (2) | A-0 | * | * | A-0 | * | A-60 | A-0 | A-0 | A-0 | * | A-30 ^g |
| Accommodation spaces | | (3) | A-60 | A-0 | * | A-0 | * | A-60 | A-0 | A-0 | A-0 | * | A-30 A-0 ^d |
| Stairways | | (4) | A-0 | A-0 | A-0 | * | A-0 | A-60 | A-0 | A-0 | A-0 | * | A-30 ^g |
| Service spaces (low risk) | | (5) | A-15 | A-0 | A-0 | A-0 | * | A-60 | A-0 | A-0 | A-0 | * | A-0 |
| Machinery spaces of category A | | (6) | A-60 | A-60 | A-60 | A-60 | A-60 | * | A-60 ^f | A-30 | A-60 | * | A-60 |
| Other machinery spaces | | (7) | A-15 | A-0 | A-0 | A-0 | A-0 | A-0 | * | A-0 | A-0 | * | A-0 |
| Cargo spaces | | (8) | A-60 | A-0 | A-0 | A-0 | A-0 | A-0 | A-0 | * | A-0 | * | A-0 |
| Service spaces (high risk)) | | (9) | A-60 | A-30 A-0 ^d | A-30 A-0 ^d | A-30 A-0 ^d | A-0 | A-60 | A-0 | A-0 | A-0 | * | A-30 |
| Open decks | | (10) | * | * | * | * | * | * | * | * | * | – | A-0 |
| Special category and ro-ro spaces | | (11) | A-60 | A-30 ^g | A-30 A-0 ^d | A-30 ^g | A-0 | A-60 ^g | A-0 | A-0 | A-30 | A-0 | A-30 ^g |

Notes to be applied to Table 9.3 and Table 9.4, as appropriate:

- a For clarification as to which applies, see 9.2.2.2 and 9.2.2.5.
- b Where spaces are of the same numerical category and superscript “b” appears, a bulkhead or deck of the rating shown in the tables is only required when the adjacent spaces are for a different purpose (e.g., in category (9)). A galley next to galley does not require a bulkhead, but a galley next to a paint locker requires an “A-0” bulkhead.
- c Bulkheads separating the wheelhouse and chartroom from each other may be of “B-0” rating. No fire rating is required for those partitions separating the navigation bridge and the safety centre when the latter is within the navigation bridge.
- d See 9.2.2.4.2.3 and 9.2.2.4.2.4.
- e For the application of 9.2.2.1.1.2, “B-0” and “C”, where appearing in the Table 9.3 shall be read as “A-0”.
- f Fire insulation need not be fitted if the machinery spaces in category (7) having little or no fire risk, i.e. if do not contain machinery using fuel oil or having a pressure lubrication system.
- g Ships constructed before 1 July 2014 shall comply, as a minimum, with the previous requirements of the Rules for the classification of ships applicable at the time the ship was constructed.
- * Where an asterisk appears in the tables, the division is required to be of steel or other equivalent material but is not required to be of “A” class standard.
However, where a deck, except in a category (10) space, is penetrated for the passage of electric cables, pipes and vent ducts, such penetrations shall be made tight to prevent the passage of flame and smoke. Divisions between control stations (emergency generators) and open decks may have air intake openings without means for closure, unless a fixed gas fire-extinguishing system is fitted.
For the application of 9.2.2.1.1.2 an asterisk, where appearing in the Table 9.4, except for categories (8) and (10), shall be read as “A-0”.

9.2.2.4.3 Continuous “B” class ceilings or linings, in association with the relevant decks or bulkheads, may be accepted as contributing, wholly or in part, to the required insulation and integrity of a division, providing that they are fire tested in accordance with the FTP Code.

9.2.2.4.4 External boundaries which are required in 11.2 to be of steel or other equivalent material may be pierced for the fitting of windows and sidescuttles provided that there is no requirement for such boundaries of passenger ships to have “A” class integrity. Similarly, in such boundaries which are not required to have “A” class integrity, doors may be constructed of materials which are to the satisfaction of the Register (see the *Rules for the classification of ships, Part 3 – Hull Equipment*, 7.2 and 7.5).

9.2.2.4.5 Saunas shall comply with 9.2.2.3.4.

9.2.2.5 Protection of stairways and lifts in accommodation area

9.2.2.5.1 Stairways shall be within enclosures formed of “A” class divisions, with positive means of closure at all openings, except that:

- .1 a stairway connecting only two decks need not be enclosed, provided the integrity of the deck is maintained by proper bulkheads or self-closing doors in one ’tween-deck space. When a stairway is closed in one ’tween-deck space, the stairway enclosure shall be protected in accordance with

the tables for decks in 9.2.2.3 or 9.2.2.4; and

- .2 stairways may be fitted in the open in a public space, provided they lie wholly within the public space.

9.2.2.5.2 Lift trunks shall be so fitted as to prevent the passage of smoke and flame from one 'tween-deck to another and shall be provided with means of closing so as to permit the control of draught and smoke.

Machinery for lifts located within stairway enclosures shall be arranged in a separate room, surrounded by steel boundaries, except that small passages for lift cables are permitted.

Lifts which open into spaces other than corridors, public spaces, special category spaces, stairways and external areas shall not open into stairways included in the means of escape.

9.2.2.6 Arrangement of cabin balconies

On passenger ships, non-load-bearing partial bulkheads which separate adjacent cabin balconies shall be capable of being opened by the crew from each side for the purpose of fighting fires.

9.2.2.7 Protection of atriums

9.2.2.7.1 Atriums shall be within enclosures formed of "A" class divisions having a fire rating determined in accordance with tables 9.2 and 9.4, as applicable.

9.2.2.7.2 Decks separating spaces within atriums shall have a fire rating determined in accordance with tables 9.2 and 9.4, as applicable.

9.2.3 Cargo ships except tankers

For tankers (>60°C) see additional requirements in 9.8.

For special purpose ships see additional requirements in 9.9.

For oil recovery ships see additional requirements in 9.10.

For firefighting ships see additional requirements in 9.11.

9.2.3.1 Methods of protection in accommodation area

9.2.3.1.1 One of the following methods of protection shall be adopted in accommodation and service spaces and control stations:

- .1 *Method IC* - The construction of internal divisional bulkheads of non-combustible "B" or "C" class divisions generally without the installation of an automatic sprinkler, fire detection and fire alarm system in the accommodation and service spaces, except as required by 7.5.5.1; or
- .2 *Method IIC* - The fitting of an automatic sprinkler, fire detection and fire alarm system as required by 7.5.5.2 for the detection and extinction of fire in all spaces in which fire might be expected to originate, gener-

ally with no restriction on the type of internal divisional bulkheads; or

- .3 *Method IIIC* - The fitting of a fixed fire detection and fire alarm system as required by 7.5.5.3 in spaces in which a fire might be expected to originate, generally with no restriction on the type of internal divisional bulkheads, except that in no case shall the area of any accommodation space or spaces bounded by an "A" or "B" class division exceed 50 m². However, consideration may be given by the *Register* to increasing this area for public spaces.

9.2.3.1.2 The requirements for the use of non-combustible materials in the construction and insulation of boundary bulkheads of machinery spaces, control stations, service spaces, etc., and the protection of the above stairway enclosures and corridors will be common to all three methods outlined in 9.2.3.1.1.

9.2.3.2 Bulkheads within accommodation area

9.2.3.2.1 Bulkheads required to be "B" class divisions shall extend from deck to deck and to the shell or other boundaries. However, where a continuous "B" class ceiling or lining is fitted on both sides of the bulkhead, the bulkhead may terminate at the continuous ceiling or lining.

9.2.3.2.2 Method IC - Bulkheads not required by this or other Sections for cargo ships to be "A" or "B" class divisions shall be of at least "C" class construction.

9.2.3.2.3 Method IIC - There shall be no restriction on the construction of bulkheads not required by this or other Sections for cargo ships to be "A" or "B" class divisions except in individual cases where "C" class bulkheads are required in accordance with table 9.5.

9.2.3.2.4 Method IIIC - There shall be no restriction on the construction of bulkheads not required for cargo ships to be "A" or "B" class divisions except that the area of any accommodation space or spaces bounded by a continuous "A" or "B" class division shall in no case exceed 50 m², except in individual cases where "C" class bulkheads are required in accordance with table 9.5. However, consideration may be given by the *Register* to increasing this area for public spaces.

9.2.3.3 Fire integrity of bulkheads and decks

9.2.3.3.1 In addition to complying with the specific provisions for fire integrity of bulkheads and decks of cargo ships, the minimum fire integrity of bulkheads and decks shall be as prescribed in tables 9.5 and 9.6.

9.2.3.3.2 The following requirements shall govern application of the tables:

- .1 Tables 9.5 and 9.6 shall apply respectively to the bulkheads and decks separating adjacent spaces.
- .2 For determining the appropriate fire integrity standards to be applied to divisions between adjacent spaces, such spaces are classified according to their fire risk as shown in categories (1) to (11) below. Where the contents and use of a space are such that there is a doubt as to its classifi-

cation for the purpose of this Section, or where it is possible to assign two or more classifications to a space, it shall be treated as a space within the relevant category having the most stringent boundary requirements. Smaller, enclosed rooms within a space that have less than 30% communicating openings to that space are considered separate spaces. The fire integrity of the boundary bulkheads and decks of such smaller rooms shall be as prescribed in tables 9.5 and 9.6. The title of each category is intended to be typical rather than restrictive. The number in parentheses preceding each category refers to the applicable column or row in the tables.

See *IACS UI SC45 Rev.1* and *MSC.1/Circ.1581*.

- (1) Control stations:
Spaces containing emergency sources of power and lighting.
Wheelhouse and chartroom.
Spaces containing the ship's radio equipment.
Fire control stations.
Control room for propulsion machinery when located outside the machinery space.
Spaces containing centralized fire alarm equipment.
- (2) Corridors:
Corridors and lobbies.
- (3) Accommodation spaces:
Spaces as defined in 3.1.2.1, excluding corridors.
- (4) Stairways:
Interior stairway, lifts, totally enclosed emergency escape trunks, and escalators (other than those wholly contained within the machinery spaces) and enclosures thereto.
In this connection, a stairway which is enclosed only at one level shall be regarded as part of the space from which it is not separated by a fire door.
- (5) Service spaces (low risk):
Lockers and store-rooms not having provisions for the storage of flammable liquids and having areas less than 4 m² and drying rooms and laundries.
See *IACS UI SC167 Rev.1 Corr.1*.
- (6) Machinery spaces of category A:
Spaces as defined in 3.1.2.31.

- (7) Other machinery spaces:
Electrical equipment rooms (auto-telephone exchange, air-conditioning duct spaces). Spaces as defined in 3.1.2.30, excluding machinery spaces of category A. See *MSC.1/Circ.1616* and *IACS UI SC294*.
- (8) Cargo spaces:
All spaces used for cargo (including cargo oil tanks) and trunkways and hatchways to such spaces.
- (9) Service spaces (high risk):
Galleys, pantries containing cooking appliances, saunas, paint lockers and store-rooms having areas of 4 m² or more, spaces for the storage of flammable liquids, and workshops other than those forming part of the machinery spaces.
- (10) Open decks:
Open deck spaces and enclosed promenades having little or no fire risk. To be considered in this category, enclosed promenades shall have no significant fire risk, meaning that furnishings shall be restricted to deck furniture. In addition, such spaces shall be naturally ventilated by permanent openings.
Air spaces (the space outside superstructures and deckhouses).
- (11) Ro-ro and vehicle spaces:
Ro-ro spaces as defined in 3.1.2.41.
Vehicle spaces as defined in 3.1.2.49.

9.2.3.3.3 Continuous "B" class ceilings or linings, in association with the relevant decks or bulkheads, may be accepted as contributing, wholly or in part, to the required insulation and integrity of a division, providing that they are fire tested in accordance with the FTP Code.

9.2.3.3.4 External boundaries which are required in 11.2 to be of steel or other equivalent material may be pierced for the fitting of windows and sidescuttles provided that there is no requirement for such boundaries of cargo ships to have "A" class integrity. Similarly, in such boundaries which are not required to have "A" class integrity, doors may be constructed of materials which are to the satisfaction of the *Register* (see the *Rules for the classification of ships, Part 3 – Hull Equipment*, 7.2 and 7.5).

9.2.3.3.5 Saunas shall comply with 9.2.2.3.4.

Table 9.5
Fire integrity of bulkheads separating adjacent spaces

| Spaces | Space categ. | (1) | (2) | (3) | (4) | (5) | (6) | (7) | (8) | (9) | (10) | (11) |
|--------------------------------|--------------|------------------|-----|------------------|-------------------------|-------------------------|------|------------------|------------------|------------------|------|-------------------|
| Control stations | (1) | A-0 ^e | A-0 | A-60 | A-0 | A-15 | A-60 | A-15 | A-60 | A-60 | * | A-60 |
| Corridors | (2) | | C | B-0 | B-0 A-0 ^c | B-0 | A-60 | A-0 | A-0 | A-0 | * | A-30 |
| Accommodation spaces | (3) | | | C ^{a,b} | B-0 A-0 ^c | B-0 | A-60 | A-0 | A-0 | A-0 | * | A-30 |
| Stairways | (4) | | | | B-0 A-0 ^c | B-0 A-0 ^c | A-60 | A-0 | A-0 | A-0 | * | A-30 |
| Service spaces (low risk) | (5) | | | | | C | A-60 | A-0 | A-0 | A-0 | * | A-0 |
| Machinery spaces of category A | (6) | | | | | | * | A-0 | A-0 ^g | A-60 | * | A-60 ^f |
| Other machinery spaces | (7) | | | | | | | A-0 ^d | A-0 | A-0 | * | A-0 |
| Cargo spaces | (8) | | | | | | | | * | A-0 | * | A-0 |
| Service spaces (high risk) | (9) | | | | | | | | | A-0 ^d | * | A-30 |
| Open decks | (10) | | | | | | | | | | – | A-0 |
| Ro-ro and vehicle spaces | (11) | | | | | | | | | | | A-30 ⁱ |

Sea notes following Table 9.6.

Table 9.6
Fire integrity of decks separating adjacent spaces

| Space below | Space categ. | Spaces above | | | | | | | | | | |
|--------------------------------|--------------|--------------|------|------|------|------|------|-------------------|------|------------------|------------------|-------------------|
| | | (1) | (2) | (3) | (4) | (5) | (6) | (7) | (8) | (9) | (10) | (11) |
| Control stations | (1) | A-0 | A-0 | A-0 | A-0 | A-0 | A-60 | A-0 | A-0 | A-0 | * | A-60 |
| Corridors | (2) | A-0 | * | * | A-0 | * | A-60 | A-0 | A-0 | A-0 | * | A-30 |
| Accommodation spaces | (3) | A-60 | A-0 | * | A-0 | * | A-60 | A-0 | A-0 | A-0 | * | A-30 |
| Stairways | (4) | A-0 | A-0 | A-0 | * | A-0 | A-60 | A-0 | A-0 | A-0 | * | A-30 |
| Service spaces (low risk) | (5) | A-15 | A-0 | A-0 | A-0 | * | A-60 | A-0 | A-0 | A-0 | * | A-0 |
| Machinery spaces of category A | (6) | A-60 | A-60 | A-60 | A-60 | A-60 | * | A-60 ⁱ | A-30 | A-60 | * | A-60 |
| Other machinery spaces | (7) | A-15 | A-0 | A-0 | A-0 | A-0 | A-0 | * | A-0 | A-0 | * | A-0 |
| Cargo spaces | (8) | A-60 | A-0 | A-0 | A-0 | A-0 | A-0 | A-0 | * | A-0 | * | A-0 |
| Service spaces (high risk) | (9) | A-60 | A-0 | A-0 | A-0 | A-0 | A-60 | A-0 | A-0 | A-0 ^d | * | A-30 |
| Open decks | (10) | * | * | * | * | * | * | * | * | * | – | A-0 ^j |
| Ro-ro and vehicle spaces | (11) | A-60 | A-30 | A-30 | A-30 | A-0 | A-60 | A-0 | A-0 | A-30 | A-0 ^j | A-30 ^j |

Notes to be applied to Table 9.5 and Table 9.6, as appropriate:

- a No special requirements are imposed upon bulkheads in methods II C and III C fire protection.
- b In case of method III C, “B” class bulkheads of “B-0” rating shall be provided between spaces or groups of spaces of 50 m² and over in area.
- c For clarification as to which applies, see 9.2.3.2 and 9.2.3.4.
- d Where spaces are of the same numerical category and superscript “d” appears, a bulkhead or deck of the rating shown in the tables is only required when the adjacent spaces are for a different purpose (e.g., in category (9)). A galley next to galley does not require a bulkhead, but a galley next to a paint room requires an “A-0” bulkhead.
- e Bulkheads separating the wheelhouse, chartroom and radio room from each other may be of “B-0” rating.

- f An “A-0” rating may be used if no dangerous goods are intended to be carried or if such goods are stowed not less than 3 m horizontally away from such a bulkhead.
- g For cargo spaces in which dangerous goods are intended to be carried, 19.3.8 applies.
- h Deleted.
- i Fire insulation need not be fitted in the machinery spaces in category (7) if, in the opinion of the *Register*, have little or no fire risk, i.e. if they do not contain machinery using fuel oil or have not a pressure lubrication system.
- j Ships constructed before 1 July 2014 shall comply, as a minimum, with the previous requirements of the Rules for the classification of ships applicable at the time the ship was constructed.
- * Where an asterisk appears in Tables, the division is required to be of steel or other equivalent material but is not required to be of “A” class integrity. However, where a deck, except an open deck, is penetrated for the passage of electric cables, pipes and vent ducts, such penetrations shall be made tight to prevent the passage of flame and smoke. Divisions between control stations (emergency generators) and open decks may have air intake openings without means for closure, unless a fixed gas fire-extinguishing system is fitted.

See also *MSC.I/Circ.1511*.

9.2.3.4 Protection of stairways and lift trunks in accommodation spaces, service spaces and control stations

9.2.3.4.1 Stairways which penetrate only a single deck shall be protected, at a minimum, at one level by at least “B-0” class divisions and self-closing doors. Lifts which penetrate only a single deck shall be surrounded by “A-0” class divisions with steel doors at both levels. Stairways and lift trunks which penetrate more than a single deck shall be surrounded by at least “A-0” class divisions and be protected by self-closing doors at all levels.

See *IACS UI SC46 Rev.1*.

9.2.3.4.2 On ships having accommodation for 12 persons or less, where stairways penetrate more than a single deck and where there are at least two escape routes direct to the open deck at every accommodation level, the “A-0” requirements of 9.2.3.4.1 may be reduced to “B-0”.

9.2.4 Tankers

9.2.4.1 Application

9.2.4.1.1 For tankers, only method IC as defined in 9.2.3.1.1 shall be used.

9.2.4.1.2 The requirements of this item shall apply to tankers and combination carriers of 300 gross tonnage and upwards carrying crude oil or petroleum products having a flash point not exceeding 60 °C (closed cup test), as determined by an approved flashpoint apparatus, and a Reid vapour pressure which is below atmospheric pressure or other liquid products having a similar fire hazard (for list of products see Annex 2).

Unless expressly provided otherwise, the application of these requirements to the ships of less than 300 gross tonnage is subject to special consideration by the *Register* in each particular case.

9.2.4.2 Fire integrity of bulkheads and decks

9.2.4.2.1 In lieu of 9.2.3 and in addition to complying with the specific provisions for fire integrity of bulkheads and decks of tankers, the minimum fire integrity of bulkheads and decks shall be as prescribed in tables 9.7 and 9.8.

9.2.4.2.2 The following requirements shall govern application of the tables:

- .1 Tables 9.7 and 9.8 shall apply respectively to the bulkhead and decks separating adjacent spaces.
- .2 For determining the appropriate fire integrity standards to be applied to divisions between adjacent spaces, such spaces are classified according to their fire risk as shown in categories (1) to (10) below. Where the contents and use of a space are such that there is a doubt as to its classification for the purpose of this Section, or where it is possible to assign two or more classifications to a space, it shall be treated as a space within the relevant category having the most stringent boundary requirements. Smaller, enclosed areas within a space that have less than 30% communicating openings to that space are considered separate areas. The fire integrity of the boundary bulkheads and decks of such smaller spaces shall be as prescribed in tables 9.7 and 9.8. The title of each category is intended to be typical rather than restrictive. The number in parentheses preceding each category refers to the applicable column or row in the tables.

See *IACS UI SC45 Rev.1. and MSC.I/Circ.1581*.

- (1) Control stations
 - Spaces containing emergency sources of power and lighting.
 - Wheelhouse and chartroom.
 - Spaces containing the ship’s radio equipment.
 - Fire control stations.
 - Control room for propulsion machinery when located outside the machinery space.
 - Spaces containing centralized fire alarm equipment.
- (2) Corridors
 - Corridors and lobbies.
- (3) Accommodation spaces
 - Spaces as defined in 3.1.2.1, excluding corridors.
- (4) Stairways
 - Interior stairways, lifts, totally enclosed emergency escape trunks, and

escalators (other than those wholly contained within the machinery spaces) and enclosures thereto.

In this connection, a stairway which is enclosed only at one level shall be regarded as part of the space from which it is not separated by a fire door.

- (5) Service spaces (low risk)
Lockers and store-rooms not having provisions for the storage of flammable liquids and having areas less than 4 m² and drying rooms and laundries.
See *IACS UI SC167 Rev.1 Corr.1*.
- (6) Machinery spaces of category A
Spaces as defined in 3.1.2.31.
- (7) Other machinery spaces
Electrical equipment rooms (auto-telephone exchange and air-conditioning duct spaces). Spaces as defined in 3.1.2.30, excluding machinery spaces of category A. See *MSC.1/Circ.1616 and IACS UI SC294*.
- (8) Cargo pump-rooms
Spaces containing cargo pumps and entrances and trunks to such spaces.
- (9) Service spaces (high risk)
Galleys, pantries containing cooking appliances, saunas, paint lockers and store-rooms having areas of 4 m² or more, spaces for the storage of flammable liquids and workshops other than those forming part of the machinery spaces.
- (10) Open decks
Open deck spaces and enclosed promenades having little or no fire risk. To be considered in this category, enclosed promenades shall have no significant fire risk, meaning that furnishings shall be restricted to deck furniture. In addition, such spaces shall be naturally ventilated by permanent openings.
Air spaces (the space outside superstructures and deckhouses).

9.2.4.2.3 Continuous “B” class ceilings or linings, in association with the relevant decks or bulkheads, may be accepted as contributing, wholly or in part, to the required insulation and integrity of a division, providing that they are fire tested in accordance with the FTP Code.

9.2.4.2.4 External boundaries which are required in 11.2 to be of steel or other equivalent material may be pierced for the fitting of windows and sidescuttles provided that there is no requirement for such boundaries of tankers to have “A” class integrity. Similarly, in such boundaries which are not required to have “A” class integrity, doors may be constructed of materials which are to the satisfaction of the Register, (see the *Rules for the classification of ships, Part 3 – Hull Equipment*, 7.2 and 7.5).

9.2.4.2.5 Exterior boundaries of superstructures and deckhouses enclosing accommodation and including any overhanging decks which support such accommodation shall be constructed of steel and insulated to “A-60” standard for the whole of the portions which face the cargo area and on the outward sides for a distance of 3 m from the end boundary facing the cargo area. The distance of 3 m shall be measured horizontally and parallel to the middle line of the ship from the boundary which faces the cargo area at each deck level. In the case of the sides of those superstructures and deckhouses, such insulation shall be carried up to the underside of the deck of the navigation bridge. See the *IACS UI SC174 Rev.1*.

9.2.4.2.6 Skylights to cargo pump-rooms shall be of steel, shall not contain any glass and shall be capable of being closed from outside the pump-room.

9.2.4.2.7 Construction and arrangement of saunas shall comply with 9.2.2.3.4.

9.2.4.3 Cathodic protection on oil tankers shall be in compliance with following requirements (IACS UR F1 Rev.1):

- .1 Impressed current systems are not permitted in oil cargo tanks.
- .2 Magnesium or magnesium alloy anodes are not permitted in oil cargo tanks and tanks adjacent to cargo tanks.
- .3 Aluminium anodes are only permitted in cargo tanks and tanks adjacent to cargo tanks in locations where the potential energy does not exceed 28 kg m (200 ft lb). The height of the anode is to be measured from the bottom of the tank to the centre of the anode, and its weight is to be taken as the weight of the anode as fitted, including the fitting devices and inserts. However, where aluminium anodes are located on horizontal surfaces such as bulkhead girders and stringers not less than 1 m wide and fitted with an upstanding flange or face flat projecting not less than 75 mm above the horizontal surface, the height of the anode may be measured from this surface. Aluminium anodes are not to be located under tank hatches or Butterworth openings (in order to avoid any metal parts falling on the fitted anodes), unless protected by adjacent structure.
- .4 There is no restriction on the positioning of zinc anodes.
- .5 The anodes should have steel cores and these should be sufficiently rigid to avoid resonance in the anode support and be designed so that they retain the anode even when it is wasted.
- .6 The steel inserts are to be attached to the structure by means of a continuous weld of adequate section. Alternatively they may be attached to separate supports by bolting, provided a minimum of two bolts with locknuts are used. However, approved mechanical means of clamping will be accepted.

.7 The supports at each end of an anode should not be attached to separate items which are likely to move independently.

.8 When anode inserts or supports are welded to the structure, they should be arranged so that the welds are clear of stress raiser.

Table 9.7
Fire integrity of bulkheads separating adjacent spaces

| Spaces | Space categ. | (1) | (2) | (3) | (4) | (5) | (6) | (7) | (8) | (9) | (10) |
|--------------------------------|--------------|------------------|-----|------|-------------------------|-------------------------|------|------------------|------------------|------------------|------|
| Control stations | (1) | A-0 ^c | A-0 | A-60 | A-0 | A-15 | A-60 | A-15 | A-60 | A-60 | * |
| Corridors | (2) | | C | B-0 | B-0 A-0 ^a | B-0 | A-60 | A-0 | A-60 | A-0 | * |
| Accommodation spaces | (3) | | | C | B-0 A-0 ^a | B-0 | A-60 | A-0 | A-60 | A-0 | * |
| Stairways | (4) | | | | B-0 A-0 ^a | B-0 A-0 ^a | A-60 | A-0 | A-60 | A-0 | * |
| Service spaces (low risk) | (5) | | | | | C | A-60 | A-0 | A-60 | A-0 | * |
| Machinery spaces of category A | (6) | | | | | | * | A-0 | A-0 ^d | A-60 | * |
| Other machinery spaces | (7) | | | | | | | A-0 ^b | A-0 | A-0 | * |
| Cargo pump-rooms | (8) | | | | | | | | * | A-60 | * |
| Service spaces (high risk) | (9) | | | | | | | | | A-0 ^b | * |
| Open decks | (10) | | | | | | | | | | - |

See notes following Table 9.8.

Table 9.8
Fire integrity of decks separating adjacent spaces

| Space | above | Space categ. | (1) | (2) | (3) | (4) | (5) | (6) | (7) | (8) | (9) | (10) |
|--------------------------------|-------|--------------|------|------|------|------|------|------------------|-------------------|-----|------------------|------|
| | below | | | | | | | | | | | |
| Control stations | | (1) | A-0 | A-0 | A-0 | A-0 | A-0 | A-60 | A-0 | - | A-0 | * |
| Corridors | | (2) | A-0 | * | * | A-0 | * | A-60 | A-0 | - | A-0 | * |
| Accommodation spaces | | (3) | A-60 | A-0 | * | A-0 | * | A-60 | A-0 | - | A-0 | * |
| Stairways | | (4) | A-0 | A-0 | A-0 | * | A-0 | A-60 | A-0 | - | A-0 | * |
| Service spaces (low risk) | | (5) | A-15 | A-0 | A-0 | A-0 | * | A-60 | A-0 | - | A-0 | * |
| Machinery spaces of category A | | (6) | A-60 | A-60 | A-60 | A-60 | A-60 | * | A-60 ^e | A-0 | A-60 | * |
| Other machinery spaces | | (7) | A-15 | A-0 | A-0 | A-0 | A-0 | A-0 | * | A-0 | A-0 | * |
| Cargo pump-rooms | | (8) | - | - | - | - | - | A-0 ^d | A-0 | * | - | * |
| Service spaces (high risk) | | (9) | A-60 | A-0 | A-0 | A-0 | A-0 | A-60 | A-0 | - | A-0 ^b | * |
| Open decks | | (10) | * | * | * | * | * | * | * | * | * | - |

Notes to be applied to Table 9.7 and Table 9.8, as appropriate:

- a For clarification as to which applies see 9.2.3.2 and 9.2.3.4.
- b Where spaces are of the same numerical category and superscript “b” appears, a bulkhead or deck of the rating shown in tables is only required when the adjacent spaces are for a different purpose (e.g., in category (9)). A galley next to a galley does not require a bulkhead, but a galley next to a paint room requires an “A-0” bulkhead.
- c Bulkheads separating the wheelhouse, chartroom and radio room from each other may be of “B-0” rating.
- d For penetrations of bulkheads and decks between cargo-pump rooms and machinery spaces of category A by cargo-pump shaft glands and similar glanded penetrations see 4.5.10.1.1.
- e Fire insulation need not be fitted if the machinery spaces in category (7), in the opinion of the *Register*, has little or no fire risk, i. e. if do not contain machinery using fuel oil or have not a pressure lubricating system.
- * Where an asterisk appears in tables, the division is required to be of steel or other equivalent material, but is not required to be of “A” class integrity.

However, where a deck, except an open deck, is penetrated for the passage of electric cables, pipes and vent ducts, such penetrations shall be made tight to prevent the passage of flame and smoke. Divisions between control stations (emergency generators) and open decks may have air intake openings without means for closure, unless a fixed gas fire-extinguishing system is fitted.

9.2.4.4 Aluminium coatings on board oil tankers and chemical tankers shall be in compliance with following requirements (IACS UR F2 Rev.2):

- .1 The use of aluminium coatings containing greater than 10 percent aluminium by weight in the dry film is prohibited in cargo tanks, cargo tank deck area, pump rooms, cofferdams or any other area where cargo vapour may accumulate. Aluminised pipes may be permitted in ballast tanks, in inerted cargo tanks and, provided the pipes are protected from accidental impact, in hazardous areas on open deck.
- .2 Requirements in 9.2.4.4.1 applies to new tankers and new applications of coating and piping on existing tankers.

9.2.4.5 Ullage plugs, sighting ports and tank cleaning openings are not to be arranged in enclosed spaces (IACS UR F3).

9.2.4.6 Side-fenders shall be of non-sparking construction, i.e. non-metallic or any other sparking hazardless construction.

9.2.4.7 Safe access to the bow

Means shall be provided to enable the crew to gain safe access to the bow, even in severe weather conditions, which shall be to the satisfaction of the *Register* (see resolution *MSC.62(67) Rev.1* and *IACS UI SC253 Rev.1*). The access shall be by means of either a walkway on the deck or a permanently constructed gangway of substantial strength at or above the level of the superstructure deck or the first tier of a deck-house which shall be constructed of fire resistant and non-slip material.

FRP gratings used in lieu of steel gratings for safe access to tanker bows shall possess:

- .1 low flame spread characteristics and shall not generate excessive quantities of smoke and toxic products as per the FTP Code; and
- .2 adequate structural fire integrity as per recognized standards, for example USCG F 3059-14 (see *IACS UI SC253 Rev.1*)

after undergoing tests in accordance with the above standards.

9.3 PENETRATIONS IN FIRE-RESISTING DIVISIONS AND PREVENTION OF HEAT TRANSMISSION

9.3.1 Where "A" class divisions are penetrated, such penetrations shall be tested in accordance with the Fire Test Procedures Code, subject to the provisions of 9.4.1.1.5. In the case of ventilation ducts, 9.7.1.2 and 9.7.3.1 apply. However, where a pipe penetration is made of steel or equivalent material having a thickness of 3 mm or greater and a length of not less than 900 mm (preferably 450 mm on each side of the di-

vision), and there are no openings, testing is not required. Such penetrations shall be suitably insulated by extension of the insulation at the same level of the division.

For passenger ships of less than 500 gross tonnage, not engaged neither in international navigation nor on domestic line service, navigating only in summer period (April 1st to October 31st) in navigation area 6, 7 or 8, where a pipe penetration having section area of not more than 0,02 m² (pipe diameter ≤160 mm) is made of steel or equivalent material having a thickness of 3 mm or greater and a length of not less than 200 mm, and there are no openings, testing is not required.

9.3.2 Where "B" class divisions are penetrated for the passage of electric cables, pipes, trunks, ducts, etc., or for the fitting of ventilation terminals, lighting fixtures and similar devices, arrangements shall be made to ensure that the fire resistance is not impaired, subject to the provisions of 9.7.3.2. Pipes other than steel or copper that penetrate "B" class divisions shall be protected by either:

- .1 a fire-tested penetration device suitable for the fire resistance of the division pierced and the type of pipe used; or
- .2 a steel sleeve, having a thickness of not less than 1.8 mm and a length of not less than 900 mm for pipe diameters of 150 mm or more and not less than 600 mm for pipe diameters of less than 150 mm (preferably equally divided to each side of the division). The pipe shall be connected to the ends of the sleeve by flanges or couplings; or the clearance between the sleeve and the pipe shall not exceed 2.5 mm; or any clearance between pipe and sleeve shall be made tight by means of non-combustible or other suitable material.

9.3.3 Uninsulated metallic pipes penetrating "A" or "B" class divisions shall be of materials having a melting temperature which exceeds 950°C for "A-0" and 850°C for "B-0" class divisions.

9.3.4 In approving structural fire protection details, the *Register* shall have regard to the risk of heat transmission at intersections and terminal points of required thermal barriers. The insulation of a deck or bulkhead shall be carried past the penetration, intersection or terminal point for a distance of at least 450 mm in the case of steel and aluminium structures. If a space is divided with a deck or a bulkhead of "A" class standard having insulation of different values, the insulation with the higher value shall continue on the deck or bulkhead with the insulation of the lesser value for a distance of at least 450 mm.

See *MSC.1/Circ.1510*.

9.4 PROTECTION OF OPENINGS IN FIRE-RESISTING DIVISIONS

9.4.1 Openings in bulkheads and decks in passenger ships

9.4.1.1 Openings in "A" class divisions

9.4.1.1.1 Except for hatches between cargo, special category, store, and baggage spaces, and between such spaces and the weather decks, openings shall be provided with permanently attached means of closing which shall be at least as effective for resisting fires as the divisions in which they are fitted.

9.4.1.1.2 The construction of doors and door frames in "A" class divisions, with the means of securing them when closed, shall provide resistance to fire as well as to the passage of smoke and flame equivalent to that of the bulkheads in which the doors are situated, this being determined in accordance with the Fire Test Procedures Code. Such doors and door frames shall be constructed of steel or other equivalent material. Doors approved without the sill being part of the frame shall be installed such that the gap under the door does not exceed 12 mm. A non-combustible sill shall be installed under the door such that floor coverings do not extend beneath the closed door.

9.4.1.1.3 Watertight doors need not be insulated. See *MSC/Circ.1037*.

9.4.1.1.4 It shall be possible for each door to be opened and closed from each side of the bulkhead by one person only.

9.4.1.1.5 Fire doors in main vertical zone bulkheads, galley boundaries and stairway enclosures other than power-operated watertight doors and those which are normally locked shall satisfy the following requirements:

- .1 the doors shall be self-closing and be capable of closing with an angle of inclination of up to 3.5° opposing closure;
- .2 the approximate time of closure for hinged fire doors shall be no more than 40 s and no less than 10 s from the beginning of their movement with the ship in upright position. The approximate uniform rate of closure for sliding doors shall be of no more than 0.2 m/s and no less than 0.1 m/s with the ship in upright position;
- .3 the doors, except those for emergency escape trunks, shall be capable of remote release from the continuously manned central control station, either simultaneously or in groups, and shall be capable of release also individually from a position at both sides of the door. Release switches shall have an on-off function to prevent automatic resetting of the system;
- .4 hold-back hooks not subject to central control station release are prohibited;
- .5 a door closed remotely from the central control station shall be capable of being re-opened from both sides of the door by local control. After such local opening, the door shall automatically close again;

- .6 indication shall be provided at the fire door indicator panel in the continuously manned central control station whether each door is closed;
- .7 the release mechanism shall be so designed that the door will automatically close in the event of disruption of the control system or central power supply;
- .8 local power accumulators for power-operated doors shall be provided in the immediate vicinity of the doors to enable the doors to be operated at least ten times (fully opened and closed) after disruption of the control system or central power supply using the local controls;
- .9 disruption of the control system or central power supply at one door shall not impair the safe functioning of the other doors;
- .10 remote-released sliding or power-operated doors shall be equipped with an alarm that sounds at least 5 s but no more than 10 s, after the door is released from the central control station and before the door begins to move and continues sounding until the door is completely closed;
- .11 a door designed to re-open upon contacting an object in its path shall re-open not more than 1 m from the point of contact;
- .12 double-leaf doors equipped with a latch necessary for their fire integrity shall have a latch that is automatically activated by the operation of the doors when released by the system;
- .13 doors giving direct access to special category spaces which are power-operated and automatically closed need not be equipped with the alarms and remote-release mechanisms required in 9.4.1.1.5.3 and 9.4.1.1.5.10;
- .14 the components of the local control system shall be accessible for maintenance and adjusting;
- .15 power-operated doors shall be provided with a control system of an approved type which shall be able to operate in case of fire and be in accordance with the Fire Test Procedures Code. This system shall satisfy the following requirements:
 - (1) the control system shall be able to operate the door at the temperature of at least 200°C for at least 60 min, served by the power supply;
 - (2) the power supply for all other doors not subject to fire shall not be impaired; and
 - (3) at temperatures exceeding 200°C, the control system shall be automatically isolated from the power supply and shall be capable of keeping the door closed up to at least 945°C.

9.4.1.1.6 In ships carrying not more than 36 passengers, where a space is protected by an automatic sprinkler fire detection and fire alarm system complying with the provisions of

the Section 24 or fitted with a continuous “B” class ceiling, openings in decks not forming steps in main vertical zones nor bounding horizontal zones shall be closed reasonably tight and such decks shall meet the “A” class integrity requirements in so far as is reasonable and practicable in the opinion of the *Register*.

9.4.1.1.7 The requirements for “A” class integrity of the outer boundaries of a ship shall not apply to glass partitions, windows and sidescuttles, provided that there is no requirement for such boundaries to have “A” class integrity in 9.4.1.3.3. The requirements for “A” class integrity of the outer boundaries of the ship shall not apply to exterior doors, except for those in superstructures and deckhouses facing life-saving appliances, embarkation and external assembly station areas, external stairs and open decks used for escape routes. Stairway enclosure doors need not meet this requirement.

9.4.1.1.8 Except for watertight doors, weathertight doors (semi-watertight doors), doors leading to the open deck and doors which need to be reasonably gastight, all “A” class doors located in stairways, public spaces and main vertical zone bulkheads in escape routes shall be equipped with a self-closing hose port. The material, construction and fire resistance of the hose port shall be equivalent to the door into which it is fitted, and shall be a 150 mm square clear opening with the door closed and shall be inset into the lower edge of the door, opposite the door hinges or, in the case of sliding doors, nearest the opening.

9.4.1.1.9 Where it is necessary that a ventilation duct passes through a main vertical zone division, a fail-safe automatic closing fire damper shall be fitted adjacent to the division. The damper shall also be capable of being manually closed from each side of the division. The operating position shall be readily accessible and be marked in red light-reflecting colour. The duct between the division and the damper shall be of steel or other equivalent material and, if necessary, insulated to comply with the requirements of 9.3.1. The damper shall be fitted on at least one side of the division with a visible indicator showing whether the damper is in the open position.

9.4.1.2 Openings in “B” class divisions

See *IACS UI SC119 Rev.1*.

9.4.1.2.1 Doors and door frames in “B” class divisions and means of securing them shall provide a method of closure which shall have resistance to fire equivalent to that of the divisions, this being determined in accordance with the Fire Test Procedures Code except that ventilation openings may be permitted in the lower portion of such doors. Where such opening is in or under a door, the total net area of any such opening or openings shall not exceed 0.05 m². Alternatively, a non-combustible air balance duct routed between the cabin and the corridor, and located below the sanitary unit, is permitted where the cross-sectional area of the duct does not exceed 0.05 m². All ventilation openings shall be fitted with a grill made of non-combustible material. Doors shall be non-combustible. Doors approved without the sill being part of the frame shall be installed such that the gap under the door does not exceed 25 mm.

9.4.1.2.2 Cabin doors in “B” class divisions shall be of a self-closing type.

Hold-back hooks are not permitted.

9.4.1.2.3 The requirements for “B” class integrity of the outer boundaries of a ship shall not apply to glass partitions, windows and sidescuttles. Similarly, the requirements for “B” class integrity shall not apply to exterior doors in superstructures and deckhouses. For ships carrying not more than 36 passengers, the Register may permit the use of combustible materials in doors separating cabins from the individual interior sanitary spaces such as showers.

9.4.1.2.4 In ships carrying not more than 36 passengers, where an automatic sprinkler system complying with the provisions of the Section 24 is fitted:

- .1 openings in decks not forming steps in main vertical zones nor bounding horizontal zones shall be closed reasonably tight and such decks shall meet the “B” class integrity requirements in so far as is reasonable and practicable in the opinion of the *Register*; and
- .2 openings in corridor bulkheads of “B” class materials shall be protected in accordance with the provisions of 9.2.2.2.

9.4.1.3 Windows and sidescuttles

9.4.1.3.1 Windows and sidescuttles in bulkheads within accommodation and service spaces and control stations other than those to which the provisions of 9.4.1.1.6 and 9.4.1.2.3 apply shall be so constructed as to preserve the integrity requirements of the type of bulkheads in which they are fitted, this being determined in accordance with the Fire Test Procedures Code.

9.4.1.3.2 Notwithstanding the requirements of tables 9.1 to 9.4, windows and sidescuttles in bulkheads separating accommodation and service spaces and control stations from weather shall be constructed with frames of steel or other suitable material. The glass shall be retained by a metal glazing bead or angle.

9.4.1.3.3 Windows facing life-saving appliances, embarkation and assembly stations, external stairs and open decks used for escape routes, and windows situated below liferaft and escape slide embarkation areas shall have fire integrity as required in table 9.1. Where automatic dedicated sprinkler heads are provided for windows, “A-0” windows may be accepted as equivalent. To be considered under this head, the sprinkler heads shall either be:

- .1 dedicated heads located above the windows, and installed in addition to the conventional ceiling sprinklers; or
- .2 conventional ceiling sprinkler heads arranged such that the window is protected by an average application rate of at least 5 l/min/m² and the additional window area is included in the calculation of the area of coverage; or
- .3 water-mist nozzles that have been tested and approved in accordance with the guidelines developed by IMO and adopted by *Register*, see *resolution A.800(19)*, as amended by *resolutions MSC.265(84)* and *MSC.284(86)*.

Windows located in the ship’s side below the lifeboat embarkation area shall have fire integrity at least equal to “A-0” class.

9.4.1.3.4 For ships carrying more than 36 passengers, windows facing survival craft, embarkation and assembly stations, external stairs and open decks used for escape routes, and windows situated below liferaft and escape slide embarkation areas shall have fire integrity as required in table 9.1. Where automatic dedicated sprinkler heads are provided for windows, "A-0" windows may be accepted as equivalent. To be considered under this paragraph, the sprinkler heads must either be:

- .1 dedicated heads located above the windows, and installed in addition to the conventional ceiling sprinklers; or
- .2 conventional ceiling sprinkler heads arranged such that the window is protected by an average application rate of at least 5 l/min per square metre and the additional window area is included in the calculation of the area of coverage; or
- .3 water-mist nozzles that have been tested and approved in accordance with the Guidelines approved by the Organization, refer to the Revised guidelines for approval of sprinkler systems equivalent to that referred to in Section 12 (resolution A.800(19), as amended). and

Windows located in the ship's side below the lifeboat embarkation area shall have fire integrity at least equal to "A-0" class.

9.4.1.3.5 For ships carrying not more than 36 passengers, windows facing survival craft and escape slide, embarkation areas and windows situated below such areas shall have fire integrity at least equal to "A-0" class.

9.4.2 Doors in fire-resisting divisions in cargo ships

See *IACS UI SC119 Rev.1*.

9.4.2.1 The fire resistance of doors shall be equivalent to that of the division in which they are fitted, this being determined in accordance with the Fire Test Procedures Code. Doors approved as "A" class without the sill being part of the frame shall be installed such that the gap under the door does not exceed 12 mm and a non-combustible sill shall be installed under the door such that floor coverings do not extend beneath the closed door. Doors approved as "B" class without the sill being part of the frame shall be installed such that the gap under the door does not exceed 25 mm. Doors and door frames in "A" class divisions shall be constructed of steel. Doors in "B" class divisions shall be non-combustible. Doors fitted in boundary bulkheads of machinery spaces of category A shall be reasonably gastight and self-closing. In ships constructed according to method IC, the *Register* may permit the use of combustible materials in doors separating cabins from individual interior sanitary accommodation such as showers.

9.4.2.2 Doors required to be self-closing shall not be fitted with hold-back hooks. However, hold-back arrangements fitted with remote release devices of the fail-safe type may be utilized.

9.4.2.3 In corridor bulkheads, ventilation openings may be permitted in and under the doors of cabins and public spaces. Ventilation openings are also permitted in "B" class doors leading to lavatories, offices, pantries, lockers and store-rooms. Except as permitted below, the openings shall be pro-

vided only in the lower half of a door. Where such an opening is in or under a door, the total net area of any such opening or openings shall not exceed 0.05 m². Alternatively, a non-combustible air balance duct routed between the cabin and the corridor, and located below the sanitary unit, is permitted where the cross-sectional area of the duct does not exceed 0.05 m². Ventilation openings, except those under the door, shall be fitted with a grill made of non-combustible material.

9.4.2.4 Watertight doors need not be insulated.

9.5 PROTECTION OF OPENINGS IN MACHINERY SPACE BOUNDARIES

9.5.1 Application

9.5.1.1 The provision of this head shall apply to machinery spaces of category A and, where the *Register* considers it desirable, to other machinery spaces.

9.5.2 Protection of openings in machinery space boundaries

9.5.2.1 The number of skylights, doors, ventilators, openings in funnels to permit exhaust ventilation and other openings to machinery spaces shall be reduced to a minimum consistent with the needs of ventilation and the proper and safe working of the ship.

9.5.2.2 Skylights shall be of steel and shall not contain glass panels.

9.5.2.3 Means of control shall be provided for closing power-operated doors or actuating release mechanisms on doors other than power-operated watertight doors. The controls shall be located outside the space concerned, where they will not be cut off in the event of fire in the space it serves.

9.5.2.4 In passenger ships, the means of control required in 9.5.2.3 shall be situated at one control position or grouped in as few positions as possible, to the satisfaction of the *Register*. Such positions shall have safe access from the open deck.

9.5.2.5 In passenger ships, doors, other than power-operated watertight doors, shall be so arranged that positive closure is assured in case of fire in the space by power-operated closing arrangements or by the provision of self-closing doors capable of closing against an inclination of 3.5° opposing closure, and having a fail-safe hold-back arrangement, provided with a remotely operated release device. Doors for emergency escape trunks need not be fitted with a fail-safe hold-back facility and a remotely operated release device.

9.5.2.6 Windows shall not be fitted in machinery space boundaries. However, this does not preclude the use of glass in control rooms within the machinery spaces.

9.5.2.7 In spaces where a fixed fire-smothering system is used (gas or equivalent aerosol systems) openings, such as skylights, ventilation inlets and outlets, openings in funnels etc., which may admit air to, or allow gas to escape from, a protected space shall have permanently attached closing arrangements.

These arrangements shall be made of steel and, in the event of fire in the space so protected, shall be capable of being operated from outside the space concerned, where

they shall not be cut off in the event of fire in the space they serve.

9.5.2.8 In addition to the watertight door separating machinery space of category A from the shaft tunnel, on the side of the tunnel a light steel fire-screen door shall be fitted capable of being operated from each side.

9.5.2.9 Purifiers and similar equipment for preparing heated fuel oil for use in boilers and machinery shall be placed in a separate room, enclosed by steel bulkheads extending from deck to deck and provided with self-closing steel doors.

9.6 PROTECTION OF CARGO SPACE BOUNDARIES

9.6.1 In passenger ships carrying more than 36 passengers, the boundary bulkheads and decks of special category and ro-ro spaces shall be insulated to "A-60" class standard. However, where a category (5), (9) or (10) space, as defined in 9.2.2.3, is on one side of the division, the standard may be reduced to "A-0". Where fuel oil tanks are below a special category space, the integrity of the deck between such spaces may be reduced to "A-0" standard.

9.6.2 In passenger ships, indicators shall be provided on the navigation bridge which shall indicate when any fire door leading to or from the special category spaces is closed.

9.6.3 In tankers, for the protection of cargo tanks carrying crude oil and petroleum products having a flashpoint not exceeding 60°C, materials readily rendered ineffective by heat shall not be used for valves, fittings, tank opening covers, cargo vent piping, and cargo piping so as to prevent the spread of fire to the cargo.

9.7 VENTILATION SYSTEMS

9.7.1 General

9.7.1.1 Ventilation ducts, including single and double wall ducts, shall be of steel or equivalent material, except flexible bellows of short length not exceeding 600 mm used for connecting fans to the ducting in air-conditioning rooms. Unless expressly provided otherwise in 9.7.1.6, any other material used in the construction of ducts, including insulation, shall also be non-combustible. However, short ducts, not generally exceeding 2 m in length and with a free cross-sectional area (even in the case of a pre-insulated duct, the area calculated on the basis of the inner dimensions of the duct itself and not the insulation) not exceeding 0.02 m², need not be of steel or equivalent material, subject to the following conditions:

- .1 the ducts shall be made of non-combustible material, which may be faced internally and externally with membranes having low flame-spread characteristics and, in each case, a calorific value (refer to the recommendations published by the International Organization for Standardization, in particular publication *ISO 1716:2002, Reaction to the fire tests for building products – Determination of the heat of combustion*) not exceeding 45

MJ/m² of their surface area for the thickness used;

- .2 the ducts are only used at the end of the ventilation device; and
- .3 the ducts are not situated less than 600 mm, measured along the duct, from an opening in an "A" or "B" class division, including continuous "B" class ceiling.

See *MSC.1/Circ.1527*. See also *IACS UI SC99 Rev.2 (MSC.1/Circ.1480)*, *IACS UI SC175* and *IACS UI SC264 Corr.1*.

9.7.1.2 The following arrangements shall be tested in accordance with the Fire Test Procedures Code:

- .1 fire dampers, including their relevant means of operation, however, the testing is not required for dampers located at the lower end of the duct in exhaust ducts for galley ranges, which must be of steel and capable of stopping the draught in the duct; and
- .2 duct penetrations through "A" class divisions. However, the test is not required where steel sleeves are directly joined to ventilation ducts by means of riveted or screwed connections or by welding.

9.7.1.3 Fire dampers shall be easily accessible. Where they are placed behind ceilings or linings, these ceilings or linings shall be provided with an inspection hatch on which the identification number of the fire damper is marked. The fire damper identification number shall also be marked on any remote controls provided.

9.7.1.4 Ventilation ducts shall be provided with hatches for inspection and cleaning. The hatches shall be located near the fire dampers.

9.7.1.5 The main inlets and outlets of ventilation systems shall be capable of being closed from outside the spaces being ventilated. The means of closing shall be easily accessible as well as prominently and permanently marked and shall indicate the operating position of the closing device.

9.7.1.6 Combustible gaskets in flanged ventilation duct connections are not permitted within 600 mm of openings in "A" or "B" class divisions and in ducts required to be of "A" class construction.

9.7.1.7 Ventilation openings or air balance ducts between two enclosed spaces shall not be provided except as permitted by 9.4.1.2.1 and 9.4.2.3.

9.7.2 Arrangement of ducts

9.7.2.1 The ventilation systems for machinery spaces of category A, vehicle spaces, ro-ro spaces, galleys, special category spaces and cargo spaces shall, in general, be separated from each other and from the ventilation systems serving other spaces. However, the galley ventilation systems on cargo ships of less than 4,000 gross tonnage and in passenger ships carrying not more than 36 passengers need not be completely separated from other ventilation systems, but may be served by separate ducts from a ventilation unit serving other spaces. In such a case, an automatic fire damper shall be fitted in the galley ventilation duct near the ventilation unit.

9.7.2.2 Ducts provided for the ventilation of machinery spaces of category A, galleys, vehicle spaces, ro-ro spaces or special category spaces shall not pass through accommodation spaces, service spaces, or control stations unless they comply with 9.7.2.4.

See *IACS UI SC192*.

9.7.2.3 Ducts provided for the ventilation of accommodation spaces, service spaces or control stations shall not pass through machinery spaces of category A, galleys, vehicle spaces, ro-ro spaces or special category spaces unless they comply with 9.7.2.4.

See *IACS UI SC221*.

9.7.2.4 As permitted by 9.7.2.2 and 9.7.2.3 ducts shall be either:

- .1.1 constructed of steel having a thickness of at least 3 mm for ducts with a free cross-sectional area of less than 0.075 m², at least 4 mm for ducts with a free cross-sectional area of between 0.075 m² and 0.45 m², and at least 5 mm for ducts with a free cross-sectional area of over 0.45 m²;
 - .1.2 suitably supported and stiffened;
 - .1.3 fitted with automatic fire dampers close to the boundaries penetrated; and
 - .1.4 insulated to "A-60" class standard from the boundaries of the spaces they serve to a point at least 5 m beyond each fire damper;
- or
- .2.1 constructed of steel in accordance with 9.7.2.4.1.1 and 9.7.2.4.1.2; and
 - .2.2 insulated to "A-60" class standard throughout the spaces they pass through, except for ducts that pass through spaces of category (9) or (10) as defined in 9.2.2.3.2.2.

9.7.2.5 For the purposes of 9.7.2.4.1.4 and 9.7.2.4.2.2, ducts shall be insulated over their entire cross-sectional external surface. Ducts that are outside but adjacent to the specified space, and share one or more surfaces with it, shall be considered to pass through the specified space, and shall be insulated over the surface they share with the space for a distance of 450 mm past the duct (see *MSC.1/Circ.1276/Rev.1*).

9.7.2.6 Where it is necessary that a ventilation duct passes through a main vertical zone division, an automatic fire damper shall be fitted adjacent to the division. The damper shall also be capable of being manually closed from each side of the division. The control location shall be readily accessible and be clearly and prominently marked. The duct between the division and the damper shall be constructed of steel in accordance with 9.7.2.4.1.1 and 9.7.2.4.1.2 and insulated to at least the same fire integrity as the division penetrated. The damper shall be fitted on at least one side of the division with a visible indicator showing the operating position of the damper.

9.7.3 Details of fire dampers and duct penetrations

9.7.3.1 Ducts passing through "A" class divisions shall meet the following requirements:

- .1 where a thin plated duct with a free cross sectional area equal to, or less than, 0.02 m² passes through "A" class divisions, the opening shall be fitted with a steel sheet sleeve having a thickness of at least 3 mm and a length of at least 200 mm, divided preferably into 100 mm on each side of a bulkhead or, in the case of a deck, wholly laid on the lower side of the decks penetrated;
- .2 where ventilation ducts with a free cross-sectional area exceeding 0.02 m², but not more than 0.075 m², pass through "A" class divisions, the openings shall be lined with steel sheet sleeves. The ducts and sleeves shall have a thickness of at least 3 mm and a length of at least 900 mm. When passing through bulkheads, this length shall be divided preferably into 450 mm on each side of the bulkhead. These ducts, or sleeves lining such ducts, shall be provided with fire insulation. The insulation shall have at least the same fire integrity as the division through which the duct passes. See *MSC.1/Circ.1655* and *IACS UI SC 300*; and
- .3 automatic fire dampers shall be fitted in all ducts with a free cross-sectional area exceeding 0.075 m² that pass through "A" class divisions. Each damper shall be fitted close to the division penetrated and the duct between the damper and the division penetrated shall be constructed of steel in accordance with 9.7.2.4.2.1 and 9.7.2.4.2.2. The fire damper shall operate automatically, but shall also be capable of being closed manually from both sides of the division. The damper shall be fitted with a visible indicator which shows the operating position of the damper. Fire dampers are not required, however, where ducts pass through spaces surrounded by "A" class divisions, without serving those spaces, provided those ducts have the same fire integrity as the divisions which they penetrate. A duct of cross-sectional area exceeding 0.075 m² shall not be divided into smaller ducts at the penetration of an "A" class division and then recombined into the original duct once through the division to avoid installing the damper required by this provision.

See *IACS UI SC64, Rev.2*.

9.7.3.2 Ventilation ducts with a free cross-sectional area exceeding 0.02 m² passing through "B" class bulkheads shall be lined with steel sheet sleeves of 900 mm in length, divided preferably into 450 mm on each side of the bulkheads unless the duct is of steel for this length. See *MSC.1/Circ.1655* and *IACS UI SC 300*.

9.7.3.3 All fire dampers shall be capable of manual operation. The dampers shall have a direct mechanical means of release or, alternatively, be closed by electrical, hydraulic, or pneumatic operation. All dampers shall be manually operable

from both sides of the division. Automatic fire dampers, including those capable of remote operation, shall have a fail-safe mechanism that will close the damper in a fire even upon loss of electrical power or hydraulic or pneumatic pressure loss. Remotely operated fire dampers shall be capable of being reopened manually at the damper.

9.7.4 Ventilation systems for passenger ships carrying more than 36 passengers

9.7.4.1 In addition to the requirements in headers 7.1, 7.2 and 7.3, the ventilation system of a passenger ship carrying more than 36 passengers shall also meet the following requirements.

9.7.4.2 In general, the ventilation fans shall be so arranged that the ducts reaching the various spaces remain within a main vertical zone.

9.7.4.3 Stairway enclosures shall be served by an independent ventilation fan and duct system (exhaust and supply) which shall not serve any other spaces in the ventilation systems.

9.7.4.4 A duct, irrespective of its cross-section, serving more than one 'tween-deck accommodation space, service space or control station, shall be fitted, near the penetration of each deck of such spaces, with an automatic smoke damper that shall also be capable of being closed manually from the protected deck above the damper. Where a fan serves more than one 'tween-deck space through separate ducts within a main vertical zone, each dedicated to a single 'tween-deck space, each duct shall be provided with a manually operated smoke damper fitted close to the fan.

9.7.4.5 Vertical ducts shall, if necessary, be insulated as required by tables 9.1 and 9.2. Ducts shall be insulated as required for decks between the space they serve and the space being considered, as applicable.

9.7.5 Exhaust ducts from galley ranges

9.7.5.1 Requirements for passenger ships carrying more than 36 passengers

See *IACS UI SC108 Rev.1* and *IACS UI SC118 Rev.2*.

9.7.5.1.1 In addition to the requirements in headers 7.1, 7.2 and 7.3, exhaust ducts from galley ranges shall be constructed in accordance with 9.7.2.4.2.1 and 9.7.2.4.2.2 and insulated to "A-60" class standard throughout accommodation spaces, service spaces, or control stations they pass through. They shall also be fitted with:

- .1 a grease trap readily removable for cleaning unless an alternative approved grease removal system is fitted;
- .2 a fire damper located in the lower end of the duct at the junction between the duct and the galley range hood which is automatically and remotely operated and, in addition, a remotely operated fire damper located in the upper end of the duct close to the outlet of the duct;
- .3 a fixed means for extinguishing a fire within the duct, see recommendations published by the International Organization

for Standardization, in particular *publication ISO 15371:2009, Ships and marine technology – Fire-extinguishing systems for protection of galley cooking equipment*. See *MSC.1/Circ.1616*;

- .4 remote-control arrangements for shutting off the exhaust fans and supply fans, for operating the fire dampers mentioned in 9.7.5.1.1.2 and for operating the fire-extinguishing system, which shall be placed in a position outside the galley close to the entrance to the galley. Where a multi-branch system is installed, a remote means located with the above controls shall be provided to close all branches exhausting through the same main duct before an extinguishing medium is released into the system; and
- .5 suitably located hatches for inspection and cleaning, including one provided close to the exhaust fan and one fitted in the lower end where grease accumulates.

9.7.5.1.2 Exhaust ducts from ranges for cooking equipment installed on open decks shall conform to 9.7.5.1.1, as applicable, when passing through accommodation spaces or spaces containing combustible materials.

9.7.5.2 Requirements for cargo ships and passenger ships carrying not more than 36 passengers

9.7.5.2.1 When passing through accommodation spaces or spaces containing combustible materials, the exhaust ducts from galley ranges shall be constructed in accordance with 9.7.2.4.1.1 and 9.7.2.4.1.2. Each exhaust duct shall be fitted with:

- .1 a grease trap readily removable for cleaning;
- .2 an automatically and remotely operated fire damper located in the lower end of the duct at the junction between the duct and the galley range hood and, in addition, a remotely operated fire damper in the upper end of the duct close to the outlet of the duct;
- .3 arrangements, operable from within the galley, for shutting off the exhaust and supply fans; and
- .4 fixed means for extinguishing a fire within the duct, see recommendations published by the International Organization for Standardization, in particular *publication ISO 15371:2009, Ships and marine technology – Fire-extinguishing systems for protection of galley cooking equipment*. See *MSC.1/Circ.1616*.

See *IACS UI SC106 Rev.1*, *IACS UI SC118 Rev.2* and *IACS UI SC221*.

9.7.6 Ventilation rooms serving machinery spaces of category A containing internal combustion machinery

9.7.6.1 Where a ventilation room serves only such an adjacent machinery space and there is no fire division between

the ventilation room and the machinery space, the means for closing the ventilation duct or ducts serving the machinery space shall be located outside of the ventilation room and machinery space.

9.7.6.2 Where a ventilation room serves such a machinery space as well as other spaces and is separated from the machinery space by a "A-0" class division, including penetrations, the means for closing the ventilation duct or ducts for the machinery space can be located in the ventilation room.

9.7.7 Ventilation systems for laundries in passenger ships carrying more than 36 passengers

Exhaust ducts from laundries and drying rooms of category (13) spaces as defined in 9.2.2.3.2.2 shall be fitted with:

- .1 filters readily removable for cleaning purposes;
- .2 a fire damper located in the lower end of the duct which is automatically and remotely operated;
- .3 remote-control arrangements for shutting off the exhaust fans and supply fans from within the space and for operating the fire damper mentioned in 9.7.7.2; and
- .4 suitably located hatches for inspection and cleaning.

9.8 TANKERS (> 60°C)

9.8.1 The requirements of this head are in addition to the requirements specified in 9.2.3 and shall apply to tankers of 300 gross tonnage and upwards carrying liquid bulk cargoes of the following categories:

- .1 petroleum products with a flash point above 60°C (closed cup test) up to 100°C;
- .2 petroleum products heated to a temperature above 45°C but not higher than 15°C below their flash point;
- .3 other liquid products having a similar fire hazard.

The application of the requirements of this Section to ships of less than 300 gross tonnage is subject to special consideration by the *Register* in each particular case.

See *IACS UI SC48 Rev.1*.

The requirements of this head are at present limited to the liquid cargoes listed in Annex 3.

9.8.2 Tankers specified in 9.8.1 shall comply with the requirements in 10.2.1.4.4 and 10.10.2.3 and with the requirements for cargo ships other than tankers, except that, in lieu of the fixed fire-extinguishing system required in 10.7, they shall be fitted with the fixed deck foam system which shall be in compliance with Section 24.

9.8.3 Cargo tanks shall not be adjacent to accommodation spaces.

9.8.4 No doors leading to accommodation and service spaces shall be permitted in boundary bulkhead of superstructures and deckhouses facing the cargo tanks deck area.

9.8.5 A permanent continuous coaming of not less than 150 mm in height and extending from side to side shall

be fitted on the upper deck at a distance of about 2 m from a superstructure where accommodation and service spaces are located.

9.8.6 Machinery spaces of category A shall be arranged aft of cargo and slop tank area.

9.8.7 Where cargo heating arrangements are fitted, provision shall be made to prevent cargo from heating to the temperature higher than 45 oC, i.e. higher than 15 oC below the flashpoint of the cargo.

9.9 SPECIAL PURPOSE SHIPS

9.9.1 Application

9.9.1.1 The requirements of this Section shall apply to special purpose ships of 300 gross tonnage and upwards, which carry more than 12 special personnel (see *resolution MSC.266(84)*, as amended by *MSC.408(96)*). See also *MSC.1/Circ.1422*.

9.9.1.2 The application of this Section to ships of less than 300 gross tonnage is subject to special consideration by the *Register* in each particular case.

9.9.2 General requirements

9.9.2.1 For ships carrying more than 240 persons on board, the requirements of 9.2.2.3 for passenger ships carrying more than 36 passengers shall be applied.

9.9.2.2 For ships carrying more than 60 persons on board, but not more than 240, the requirements of 9.2.2.4 for passenger ships carrying not more than 36 passengers shall be applied.

9.9.2.3 For ships carrying not more than 60 persons on board, the requirements of 9.2.3 as for cargo ships of 500 gross tonnage and upwards, shall be applied.

9.9.2.4 In applying the requirements in 9.9.2.1, the minimum fire integrity of bulkheads and decks separating workshops and laboratories from other spaces shall comply with the requirements as for category (10) and (14) spaces, as appropriate.

9.9.2.5 In applying the requirements in 9.9.2.2 and 9.9.2.3, the minimum fire integrity of bulkheads and decks separating workshops and laboratories from other spaces shall comply with the requirements as for category (5) and (9) spaces, as appropriate.

9.9.2.6 Ships intended to carry dangerous goods for shipment as cargo, and not used on board, shall comply with the requirements of Section 19, also.

For that purpose appropriate provisions of the IMDG Code regarding construction, loading, stowage and segregation shall be taken into account at the design stage of the ship.

9.10 OIL RECOVERY SHIPS

9.10.1 The requirements of this Section are in addition to the requirements specified in 9.2.3 and apply to ships intended for recovery operations, including occasionally storage

and transportation, of oil with flash point not exceeding 60 °C from spills in marine environment oil pollution accidents.

- 9.10.2** The oil recovery ship shall be provided with:
- .1 suitable working deck for use in oil recovery operations;
 - .2 storage tanks for recovered oil;
 - .3 skimming equipment and pumping and piping arrangements for recovery and transfer of oil.

9.10.3 The hull, superstructures, structural bulkheads, decks and deckhouses shall be constructed of steel.

9.10.4 Tanks intended for storage of recovered oil and the deck area, from where the oil recovery operations are performed, shall be as far away from the accommodation and service spaces and control stations as possible.

9.10.5 The storage tanks shall be separated from the accommodation, service and machinery spaces by cofferdams, oil fuel bunker tanks or ballast tanks.

Where cofferdams are fitted a width of not less than 600 mm shall be provided.

9.10.6 All openings to the storage tanks, including access for cleaning and gas-freeing shall be located on the open deck.

9.10.7 Exterior boundaries of superstructures and deckhouses enclosing accommodation and including any overhanging decks which support such accommodation, shall be insulated to "A-60" standard for the whole of the portions which face the operation deck area and for 3 m aft or forward on the sides, as appropriate.

9.10.8 Suitable metal covers, ready to be fitted from inside, shall be provided for windows and sidescuttles fitted within the limits referred to in 9.10.7.

9.10.9 Alternatively, in lieu of the "A-60" class insulation required and where it is impractical to fit deadlights to wheelhouse windows (see 9.10.7 and 9.10.8), a fixed drenching system (see 24.18) capable of being controlled from the wheelhouse may be accepted.

9.10.10 Generally, entrances, ventilation openings and all other openings into non-hazardous locations such as accommodation, service and machinery spaces shall be located outside hazardous zones.

However, where this is impractical, the *Register* may accept entrances between such spaces provided penetration of hazardous vapours is avoided as follows:

- .1 air locks complying with 9.10.11 shall be provided;
- .2 spaces shall be fitted with mechanical supply ventilation;
- .3 warning signs shall be fitted that doors shall be kept closed during oil recovery operations.

No air locks shall be required for wheelhouse doors provided they can be made rapidly and efficiently gas and vapour tight.

Spaces having openings and entrances located in hazardous zones and not provided with air locks shall be regarded as hazardous.

9.10.11 An air lock shall consist of two steel doors substantially gastight which shall be spaced not less than 1,5 m apart. The doors shall be selfclosing and without any holding back arrangements. The door sill shall not be less than 300 mm in height.

The design of air locks shall be such that they are flushed with air from inside outwards in order to remove any vapours/gases which may have entered when using the air lock.

9.10.12 A portable hydrocarbon vapours-measuring instrument of approved type shall be provided on board. Fitting of fixed gas detection system is subject to special consideration by the *Register* in each particular case.

9.10.13 For protection of the operation deck area and storage tanks for recovered oil a fixed deck foam system shall be provided. Foam may be supplied by means of foam applicators.

9.10.14 In addition to 9.10.13, two dry powder fire extinguishers, each with a capacity of at least 45 kg shall be provided. The fire extinguishers shall be placed near the operation deck area where the equipment for handling of recovered oil is located, and shall be fitted with hoses of adequate length.

9.10.15 The ship shall be provided with the Operation Manual, approved by the *Register*, for the safe use of the vessel during oil recovery operation. The Operation Manual accompanied by appropriate drawings shall, in general, include the following information:

- .1 procedure for recovery of oil, oil transfer, tank cleaning, gas freeing and ballasting;
- .2 firefighting procedures, including gas detection;
- .3 stability information in all possible operational conditions.

9.10.16 The requirements specified in the *Rules for the classification of ships, Part 8 – Piping*, 4.3, 6.1 and 7.13; and *Part 12 - Electrical Equipment*, 19.2 shall be complied with.

9.11 FIRE FIGHTING SHIPS

9.11.1 The requirements of this Section are in addition to the requirements specified elsewhere in this Part of the Rules for the classification of ships and apply to ships intended for firefighting operations on other vessels and harbour facilities.

9.11.2 The hull, superstructures, structural bulkheads, decks and deckhouses shall be constructed of steel. Internal boundaries constructed of materials other than steel may be permitted, subject to special consideration by the *Register*.

9.11.3 The fixed self-protection water-spraying system shall be provided, for protection of all vertical areas of the hull and superstructures as well as monitor foundations and other fire-fighting arrangements, and is to be fitted in such a way as not to impair the necessary visibility from the wheelhouse and from the station for remote control of water monitors, also during operation of spray nozzles.

9.11.4 On ships which are not fitted with a water-spraying system complying with 9.11.3, the following requirements shall be applied:

- .1 all windows and port lights are to be fitted with efficient steel deadlights or external steel shutters, except for the wheelhouse; and
- .2 all exterior boundaries above the lightest operating waterline, including superstructures and exposed decks, are to be of steel and are to be internally insulated so as to form „A-60“ class divisions.

9.11.5 In ships of restricted service of less than 500 gross tonnage, relaxation from 9.11.3 and/or 9.11.4 may be granted, subject to special consideration by the *Register* in each particular case.

9.11.6 Ship shall be fitted with fire extinguishing systems intended for fighting of external fires.

Water fire extinguishing system shall have not less than 2400 m³/h capacity; minimum of 2 monitors shall be fitted, with minimum discharge rate 1200 m³/h per monitor. In addition to remote control system for monitors, located in control station having adequate overall visibility, a local manual control shall be provided for each monitor.

9.11.7 Ship shall be equipped with not less than 4 fireman's outfits, stored in a safe position readily accessible from the open deck. At least one spare air bottle is to be provided for each breathing apparatus. Ships are to be equipped with a high pressure air compressor complete with all fittings necessary for refilling the bottles of air breathing apparatuses. The compressor is to be located in a suitable sheltered location. The capacity of the compressor is to be sufficient to allow the refilling of the bottles of air breathing apparatuses in no more than 30 min. The compressor is to be fitted on the air suction with a suitable filter. The compressor is to be fitted with adequate separators and/or filters capable of preventing passage of oil droplets or vapours to the air bottles.

9.11.8 Means shall be provided to ensure adequate protection of firefighting systems required in 9.11.3, 9.11.6 and 9.11.7 against corrosion.

9.11.9 The water fire extinguishing systems and foam fire-extinguishing system shall be operationally tested on board the ship, to check performances.

9.11.10 Ship shall be fitted with portable high expansion foam fire extinguishing system for fighting external fires, having capacity not less than 6000m³/h, being capable of 30 minutes of continuous operation; or shall be fitted with fixed low expansion foam fire extinguishing system to the satisfaction of *Register*.

9.11.11 Additional class notation **FIR** may be assigned to ships complying with 9.11.1 to 9.11.9.

Additional class notation **FIR F** may be assigned to ships complying with 9.11.1 to 9.11.10.

10 FIRE FIGHTING

10.1 GENERAL REQUIREMENTS

10.1.1 The purpose of this Section is to suppress and swiftly extinguish a fire in the space of origin, except for 10.1.2. For this purpose, the following functional requirements shall be met:

- .1 fixed fire-extinguishing systems shall be installed, having due regard to the fire growth potential of the protected spaces; and
- .2 fire-extinguishing appliances shall be readily available.

10.1.2 For open-top container holds (for a definition of this term, refer to the *Interim guidelines for open-top containerships (MSC/Circ.608/Rev.1)*) and on deck container stowage areas on ships designed to carry containers on or above the weather deck, fire protection arrangements shall be provided for the purpose of containing a fire in the space or area of origin and cooling adjacent areas to prevent fire spread and structural damage.

10.2 WATER SUPPLY SYSTEMS

Ships shall be provided with fire pumps, fire mains, hydrants and hoses complying with the applicable requirements of this Section.

10.2.1 Fire mains and hydrants

10.2.1.1 General

Materials readily rendered ineffective by heat shall not be used for fire mains and hydrants unless adequately protected. The pipes and hydrants shall be so placed that the fire hoses may be easily coupled to them. The arrangement of pipes and hydrants shall be such as to avoid the possibility of freezing. Suitable drainage provisions shall be provided for fire main piping. Isolation valves shall be installed for all open deck fire main branches used for purposes other than fire-fighting. In ships where deck cargo may be carried, the positions of the hydrants shall be such that they are always readily accessible and the pipes shall be arranged as far as practicable to avoid risk of damage by such cargo.

10.2.1.2 Ready availability of water supply

The arrangements for the ready availability of water supply shall be:

- .1 in passenger ships:
 - .1.1 of 1,000 gross tonnage and upwards such that at least one effective jet of water is immediately available from any hydrant in an interior location and so as to ensure the continuation of the output of water by the automatic starting of one required fire pump;
 - .1.2 of less than 1,000 gross tonnage by automatic start of at least one fire pump or by remote starting from the navigation bridge of at least one fire pump. If the pump starts

automatically or if the bottom valve cannot be opened from where the pump is remotely started, the bottom valve shall always be kept open; and

- .1.3 if fitted with periodically unattended machinery spaces in accordance with requirements of other Parts of the Rules, the *Register* shall determine provisions for fixed water fire-extinguishing arrangements for such spaces equivalent to those required for normally attended machinery spaces;
- .2 in cargo ships:
 - .2.1 to the satisfaction of the *Register*; and
 - .2.2 with a periodically unattended machinery space or when only one person is required on watch, there shall be immediate water delivery from the fire main system at a suitable pressure, either by remote starting of one of the main fire pumps with remote starting from the navigation bridge and fire control station, if any, or permanent pressurization of the fire main system by one of the main fire pumps, except that the *Register* may waive this requirement for cargo ships of less than 1,600 gross tonnage if the fire pump starting arrangement in the machinery space is in an easily accessible position.

10.2.1.3 Diameter of fire mains

The diameter of the fire main and water service pipes shall be sufficient for the effective distribution of the maximum required discharge from two fire pumps operating simultaneously, except that in the case of cargo ships, other than those included in 10.7.3.2, the diameter need only be sufficient for the discharge of 140 m³/h.

See *IACS UI SC270 Rev.1*. See also *MSC.1/Circ.1550*.

10.2.1.4 Isolating valves and relief valves

10.2.1.4.1 Isolating valves to separate the section of the fire main within the machinery space containing the main fire pump or pumps from the rest of the fire main shall be fitted in an easily accessible and tenable position outside the machinery spaces. The fire main shall be so arranged that when the isolating valves are shut all the hydrants on the ship, except those in the machinery space referred to above, can be supplied with water by another fire pump or an emergency fire pump. The emergency fire pump, its seawater inlet, and suction and delivery pipes and isolating valves shall be located outside the machinery space. If this arrangement cannot be made, the sea-chest may be fitted in the machinery space if the valve is remotely controlled from a position in the same compartment as the emergency fire pump and the suction pipe is as short as practicable. Short lengths of suction or discharge piping may penetrate the machinery space, provided they are enclosed in a substantial steel casing or are insulated to "A-60" class standards. The pipes shall have substantial wall thickness, but in no case less than 11 mm, and shall be welded except for the flanged connection to the sea inlet valve. See *IACS UI SC121, Rev.2, Corr.1* and *IACS UI SC245, Rev.1*. See also *MSC.1/Circ.1456*.

For ships of less than 500 GT, navigating in restricted areas 5 to 8, equipped with fire pumps required in 10.2.2.2 located in machinery space of category A and with portable diesel engine driven emergency fire pump located outside machinery space of category A, application of this criterion is not mandatory.

10.2.1.4.2 A valve shall be fitted to serve each fire hydrant so that any fire hose may be removed while the fire pumps are in operation.

10.2.1.4.3 Relief valves shall be provided in conjunction with fire pumps if the pumps are capable of developing a pressure exceeding the design pressure of the water service pipes, hydrants and hoses. These valves shall be so placed and adjusted as to prevent excessive pressure in any part of the fire main system.

10.2.1.4.4 In tankers, isolation valves shall be fitted in the fire main at the poop front in a protected position and on the tank deck at intervals of not more than 40 m to preserve the integrity of the fire main system in case of fire or explosion. See *MSC.1/Circ.1456* and *MSC.1/Circ.1492*.

10.2.1.5 Number and position of hydrants

10.2.1.5.1 The number and position of hydrants shall be such that at least two jets of water not emanating from the same hydrant, one of which shall be from a single length of hose, may reach any part of the ship normally accessible to the passengers or crew while the ship is being navigated and any part of any cargo space when empty, any ro-ro space or any vehicle space, in which latter case the two jets shall reach any part of the space, each from a single length of hose. Furthermore, such hydrants shall be positioned near the accesses to the protected spaces.

10.2.1.5.2 In addition to the requirements in 10.2.1.5.1, passenger ships shall comply with the following:

- .1 in the accommodation, service and machinery spaces, the number and position of hydrants shall be such that the requirements of 10.2.1.5.1 may be complied with when all watertight doors and all doors in main vertical zone bulkheads are closed; and
- .2 where access is provided to a machinery space of category A at a low level from an adjacent shaft tunnel, two hydrants shall be provided external to, but near the entrance to, that machinery space. Where such access is provided from other spaces, in one of those spaces two hydrants shall be provided near the entrance to the machinery space of category A. Such provision need not be made where the tunnel or adjacent spaces are not part of the escape route.

10.2.1.6 Pressure at hydrants

With the two pumps simultaneously delivering water through the nozzles specified in 10.2.3.3, with the quantity of water as specified in 10.2.1.3, through any adjacent hydrants, the following minimum pressures shall be maintained at all hydrants:

.1 for passenger ships:

| | |
|---------------------------------|------------------------|
| 4,000 gross tonnage and upwards | 0.40 N/mm ² |
| less than 4,000 gross tonnage | 0.30 N/mm ² |

.2 for cargo ships:

| | |
|---------------------------------|------------------------|
| 6,000 gross tonnage and upwards | 0.27 N/mm ² |
| less than 6,000 gross tonnage | 0.25 N/mm ² |

and

.3 the maximum pressure at any hydrant shall not exceed that at which the effective control of a fire hose can be demonstrated.

10.2.1.7 International shore connection

10.2.1.7.1 Ships of 500 gross tonnage and upwards shall be provided with at least one international shore connection complying with the Section 24.

10.2.1.7.2 Facilities shall be available enabling such a connection to be used on either side of the ship.

10.2.1.7.3 See requirements in 24.2.

10.2.2 Fire pumps

10.2.2.1 Pumps accepted as fire pumps

Sanitary, ballast, bilge or general service pumps may be accepted as fire pumps, provided that they are not normally used for pumping oil and that if they are subject to occasional duty for the transfer or pumping of oil fuel, suitable change-over arrangements are fitted.

10.2.2.2 Number of fire pumps

Ships shall be provided with independently driven fire pumps as follows:

.1 in passenger ships of:

| | |
|----------------------|----------------|
| 4,000 GT and upwards | at least three |
| less than 4,000 GT | at least two |

.2 in cargo ships of:

| | |
|----------------------|---|
| 1,000 GT and upwards | at least two |
| less than 1,000 GT | at least two power driven pumps, one of which shall be independently driven |

10.2.2.3 Arrangement of fire pumps and fire mains

10.2.2.3.1 Fire pumps

The arrangement of sea connections, fire pumps and their sources of power shall be as to ensure that:

.1 in passenger ships of 1,000 GT and upwards, in the event of a fire in any one

compartment, all the fire pumps will not be put out of action; and

- .2 in passenger ships of less than 1,000 GT and in cargo ships, if a fire in any one compartment could put all the pumps out of action, there shall be an alternative means consisting of an emergency fire pump complying with the provisions of the Section 24 with its source of power and sea connection located outside the space where the main fire pumps or their sources of power are located. See *IACS UI SC162 Rev.1*.

For sea intakes for fire pump on ships with ICE Class following additional requirement (IACS UR F41) applies:

At least one of the fire pumps is to be connected to a sea chest which is provided with de-icing arrangements.

See *IACS UI SC163 Rev.2*.

10.2.2.3.2 Requirements for the space containing the emergency fire pump

- .1 The space containing the fire pump shall not be contiguous to the boundaries of machinery spaces of category A or those spaces containing main fire pumps. Where this is not practicable, the common bulkhead between the two spaces shall be insulated to a standard of structural fire protection equivalent to that required for a control station. See *IACS UI SC114 Rev.1*.
- .2 No direct access shall be permitted between the machinery space and the space containing the emergency fire pump and its source of power. When this is impracticable, the *Register* may accept an arrangement where the access is by means of an airlock with the door of the machinery space being of "A-60" class standard and the other door being at least steel, both reasonably gastight, self-closing and without any hold-back arrangements. Alternatively, the access may be through a watertight door capable of being operated from a space remote from the machinery space and the space containing the emergency fire pump and unlikely to be cut off in the event of fire in those spaces. In such cases, a second means of access to the space containing the emergency fire pump and its source of power shall be provided. See *MSC.1/Circ.1120/Corr.1*.
- .3 Ventilation arrangements to the space containing the independent source of power for the emergency fire pump shall be such as to preclude, as far as practicable, the possibility of smoke from a machinery space fire entering or being drawn into that space.

See *IACS Rec. No. 135*.

10.2.2.3.3 Additional pumps for cargo ships

In addition, in cargo ships where other pumps, such as general service, bilge and ballast, etc., are fitted in a machinery space, arrangements shall be made to ensure that at least one of these pumps, having the capacity and pressure required by 10.2.1.6.2 and 10.2.2.4.2, is capable of providing water to the fire main. See *IACS UI SC97 Rev.2*.

10.2.2.4 Capacity of fire pumps

10.2.2.4.1 Total capacity of required fire pumps

The required fire pumps shall be capable of delivering for fire-fighting purposes a quantity of water, at the pressure specified in 10.2.1.6, as follows:

- .1 pumps in passenger ships: the quantity of water is not less than two thirds of the quantity required to be dealt with by the bilge pumps when employed for bilge pumping; and
- .2 pumps in cargo ships, other than any emergency pump: the quantity of water is not less than four thirds of the quantity required under the *Rules for the classification of ships, Part 8 – Piping*, 2.1 to be dealt with by each of the independent bilge pumps in a passenger ship of the same dimension when employed in bilge pumping, provided that in no cargo ship, other than those included in 10.7.3.2, need the total required capacity of the fire pumps exceed 180 m³/h.
See *IACS UI SC270 Rev.1*. See also *MSC.1/Circ.1550*.

10.2.2.4.2 Capacity of each fire pump

Each of the required fire pumps (other than any emergency pump required in 10.2.2.3.1.2 for cargo ships) shall have a capacity not less than 80% of the total required capacity divided by the minimum number of required fire pumps, but in any case not less than 25 m³/h, and each such pump shall in any event be capable of delivering at least the two required jets of water. These fire pumps shall be capable of supplying the fire main system under the required conditions. Where more pumps than the minimum of required pumps are installed, such additional pumps shall have a capacity of at least 25 m³/h and shall be capable of delivering at least the two jets of water required in 10.2.1.5.1. See *IACS UI SC163 Rev.2*.

10.2.3 Fire hoses and nozzles

10.2.3.1 General specifications

See *IACS UI SC146, Rev.2*.

10.2.3.1.1 Fire hoses shall be of non-perishable material approved by the *Register* and shall be sufficient in length to project a jet of water to any of the spaces in which they may be required to be used. Each hose shall be provided with a nozzle and the necessary couplings. Hoses specified in this Rules for the classification of ships as "fire hoses" shall, together with any necessary fittings and tools, be kept ready for use in conspicuous positions near the water service hydrants or connections. Additionally, in interior locations in passenger

ships carrying more than 36 passengers, fire hoses shall be connected to the hydrants at all times. Fire hoses shall have a length of at least 10 m, but not more than:

- .1 15 m in machinery spaces;
- .2 20 m in other spaces and open decks; and
- .3 25 m for open decks on ships with a maximum breadth in excess of 30 m.

10.2.3.1.2 Unless one hose and nozzle is provided for each hydrant in the ship, there shall be complete interchangeability of hose couplings and nozzles.

10.2.3.2 Number and diameter of fire hoses

10.2.3.2.1 Ships shall be provided with fire hoses, the number and diameter of which shall be to the satisfaction of the *Register*.

10.2.3.2.2 In passenger ships, there shall be at least one fire hose for each of the hydrants required by 10.2.1.5 and these hoses shall be used only for the purposes of extinguishing fires or testing the fire-extinguishing apparatus at fire drills and surveys.

10.2.3.2.3 In cargo ships:

- .1 of 1,000 gross tonnage and upwards, the number of fire hoses to be provided shall be one for each 30 m length of the ship and one spare, but in no case less than five in all. This number does not include any hoses required in any engine-room or boiler room. The *Register* may increase the number of hoses required so as to ensure that hoses in sufficient number are available and accessible at all times, having regard to the type of ship and the nature of trade in which the ship is employed. Ships carrying dangerous goods in accordance with Section 19 shall be provided with three hoses and nozzles, in addition to those required above; and
- .2 of less than 1,000 gross tonnage, the number of fire hoses to be provided shall be calculated in accordance with the provisions of 10.2.3.2.3.1. However, the number of hoses shall in no case be less than three.

10.2.3.3 Size and types of nozzles

See *IACS UI SC98 Rev.1*.

10.2.3.3.1 For the purposes of this Rules for the classification of ships, standard nozzle sizes shall be 12 mm, 16 mm and 19 mm or as near thereto as possible. Larger diameter nozzles may be permitted at the discretion of the *Register*.

10.2.3.3.2 For accommodation and service spaces, a nozzle size greater than 12 mm need not be used.

10.2.3.3.3 For machinery spaces and exterior locations, the nozzle size shall be such as to obtain the maximum discharge possible from two jets at the pressure mentioned in 10.2.1.6 from the smallest pump, provided that a nozzle size greater than 19 mm need not be used.

10.2.3.3.4 Nozzles shall be of an approved dual-purpose type (i.e. spray/jet type) incorporating a shutoff.

10.3 PORTABLE FIRE EXTINGUISHERS

10.3.1 Type and design

Portable fire extinguishers shall comply with the requirements of the Section 24. See *requirements in 24.4*.

See also *Improved Guidelines for marine portable fire extinguishers (resolution A.951(23))* and *Unified interpretation of SOLAS Chapter II-2 on the number and arrangement of portable fire extinguishers on board ships (MSC.1/Circ.1275 and MSC.1/Circ.1275/Corr.1)*.

10.3.2 Arrangement of fire extinguishers

10.3.2.1 Accommodation spaces, service spaces and control stations shall be provided with portable fire extinguishers of appropriate types and in sufficient number to the satisfaction of the *Register*. Ships of 1,000 gross tonnage and upwards shall carry at least five portable fire extinguishers.

10.3.2.2 One of the portable fire extinguishers intended for use in any space shall be stowed near the entrance to that space.

10.3.2.3 Carbon dioxide fire extinguishers shall not be placed in accommodation spaces. In control stations and other spaces containing electrical or electronic equipment or appliances necessary for the safety of the ship, fire extinguishers shall be provided whose extinguishing media are neither electrically conductive nor harmful to the equipment and appliances.

10.3.2.4 Fire extinguishers shall be situated ready for use at easily visible places, which can be reached quickly and easily at any time in the event of a fire, and in such a way that their serviceability is not impaired by the weather, vibration or other external factors. Portable fire extinguishers shall be provided with devices which indicate whether they have been used.

10.3.3 Spare charges

10.3.3.1 Spare charges shall be provided for 100% of the first ten extinguishers and 50% of the remaining fire extinguishers capable of being recharged on board. Not more than sixty total spare charges are required. Instructions for recharging shall be carried on board.

10.3.3.2 For fire extinguishers which cannot be recharged on board, additional portable fire extinguishers of the same quantity, type, capacity and number as determined in 10.3.3.1 above shall be provided in lieu of spare charges.

10.4 FIXED FIRE-EXTINGUISHING SYSTEMS

10.4.1 Types of fixed fire-extinguishing systems

10.4.1.1 A fixed fire-extinguishing system required by 10.5 may be any of the following systems:

- .1 a fixed gas fire-extinguishing system complying with the provisions of the Section 24;

- .2 a fixed high-expansion foam fire-extinguishing system complying with the provisions of the Section 24; and
- .3 a fixed pressure water-spraying fire-extinguishing system complying with the provisions of the Section 24.

10.4.1.2 Where a fixed fire-extinguishing system not required by this Rules for the classification of ships is installed, it shall meet the requirements of the relevant Sections of this Rules for the classification of ships and the Section 24.

10.4.1.3 Fire-extinguishing systems using Halon 1211, 1301, and 2402 and perfluorocarbons shall be prohibited.

10.4.1.4 In general, the *Register* shall not permit the use of steam as a fire-extinguishing medium in fixed fire-extinguishing systems. Where the use of steam is permitted by the *Register*, it shall be used only in restricted areas as an addition to the required fire-extinguishing system and shall comply with the requirements of the Fire Safety System Code.

10.4.1.5 On ships constructed before 1 July 2002, fixed carbon dioxide fire-extinguishing systems for the protection of machinery spaces and cargo pump-rooms shall comply with the provisions of 24.5.2.2.2.

10.4.2 Closing appliances for fixed gas fire-extinguishing systems

Where a fixed gas fire-extinguishing system is used, openings which may admit air to, or allow gas to escape from, a protected space shall be capable of being closed from outside the protected space.

10.4.3 Storage rooms of fire-extinguishing medium

When the fire-extinguishing medium is stored outside a protected space, it shall be stored in a room which is located behind the forward collision bulkhead, and is used for no other purposes. Any entrance to such a storage room shall preferably be from the open deck and shall be independent of the protected space. If the storage space is located below deck, it shall be located no more than one deck below the open deck and shall be directly accessible by a stairway or ladder from the open deck. Spaces which are located below deck or spaces where access from the open deck is not provided shall be fitted with a mechanical ventilation system designed to take exhaust air from the bottom of the space and shall be sized to provide at least 6 air changes per hour. Access doors shall open outwards, and bulkheads and decks, including doors and other means of closing any opening therein, which form the boundaries between such rooms and adjacent enclosed spaces shall be gastight. For the purpose of the application of tables 9.1 to 9.8, such storage rooms shall be treated as fire control stations. See *IACS UI SC204, Corr.1* and *IACS UI SC260 Rev.1*. See also *MSC/Circ.1037*.

10.4.4 Water pumps for other fire-extinguishing systems

Pumps, other than those serving the fire main, required for the provision of water for fire-extinguishing systems required by this Rules for the classification of ships, their sources of power and their controls shall be installed outside the space or spaces protected by such systems and shall be so

arranged that a fire in the space or spaces protected will not put any such system out of action.

10.5 FIRE-EXTINGUISHING ARRANGEMENTS IN MACHINERY SPACES

10.5.1 Machinery spaces containing oil-fired boilers or oil fuel units

10.5.1.1 Fixed fire-extinguishing systems

Machinery spaces of category A containing oil-fired boilers or oil fuel units shall be provided with any one of the fixed fire-extinguishing systems in 10.4.1. In each case, if the engine-room and boiler room are not entirely separate, or if fuel oil can drain from the boiler room into the engine-room, the combined engine and boiler rooms shall be considered as one compartment.

10.5.1.2 Additional fire-extinguishing arrangements

See Unified interpretation of SOLAS, Chapter II-2 on the number and arrangement of portable fire extinguishers on board ships (MSC.1/Circ.1275 and MSC.1/Circ.1275/Corr.1).

This item applies to both newbuildings and existing ships.

10.5.1.2.1 There shall be in each boiler room or at an entrance outside of the boiler room at least one portable foam applicator unit complying with the provisions of the Section 24.

10.5.1.2.2 There shall be at least two portable foam extinguishers or equivalent in each firing space in each boiler room and in each space in which a part of the oil fuel installation is situated. There shall be not less than one approved foam-type extinguisher of at least 135 l capacity or equivalent in each boiler room. These extinguishers shall be provided with hoses on reels suitable for reaching any part of the boiler room. In the case of domestic boilers of less than 175 kW, or boilers protected by fixed water-based local application fire-extinguishing systems as required by 10.5.6, an approved foam-type extinguisher of at least 135 l capacity is not required.

10.5.1.2.3 In each firing space there shall be a receptacle containing at least 0.1 m³ sand, sawdust impregnated with soda, or other approved dry material, along with a suitable shovel for spreading the material. An approved portable extinguisher may be substituted as an alternative.

10.5.1.2.4 *See IACS UI SC 30 Rev.3*

10.5.2 Machinery spaces of category A containing internal combustion machinery

10.5.2.1 Fixed fire-extinguishing systems

Machinery spaces of category A containing internal combustion machinery shall be provided with one of the fixed fire-extinguishing systems in 10.4.1.

10.5.2.2 Additional fire-extinguishing arrangements

See *Unified interpretation of SOLAS, Chapter II-2 on the number and arrangement of portable fire extinguishers on board ships (MSC.1/Circ.1275 and MSC.1/Circ.1275/Corr.1)*.

10.5.2.2.1 There shall be at least one portable foam applicator unit complying with the provisions of the Section 24.

10.5.2.2.2 There shall be in each such space approved foam-type fire extinguishers, each of at least 45 l capacity or equivalent, sufficient in number to enable foam or its equivalent to be directed onto any part of the fuel and lubricating oil pressure systems, gearing and other fire hazards. In addition, there shall be provided a sufficient number of portable foam extinguishers or equivalent which shall be so located that no point in the space is more than 10 m walking distance from an extinguisher and that there are at least two such extinguishers in each such space. For smaller spaces of cargo ships the Register may consider relaxing this requirement.

10.5.2.2.3 See *IACS UI SC 30 Rev.3*.

10.5.3 Machinery spaces containing steam turbines or enclosed steam engines**10.5.3.1 Fixed fire-extinguishing systems**

In spaces containing steam turbines or enclosed steam engines used for main propulsion or other purposes having in the aggregate a total output of not less than 375 kW, one of the fire-extinguishing systems specified in 10.4.1 shall be provided if such spaces are periodically unattended.

10.5.3.2 Additional fire-extinguishing arrangements

10.5.3.2.1 There shall be approved foam fire extinguishers, each of at least 45 l capacity or equivalent, sufficient in number to enable foam or its equivalent to be directed on to any part of the pressure lubrication system, on to any part of the casings enclosing pressure-lubricated parts of the turbines, engines or associated gearing, and any other fire hazards. However, such extinguishers shall not be required if protection, at least equivalent to that required by this sub-item, is provided in such spaces by a fixed fire-extinguishing system fitted in compliance with 10.4.1.

10.5.3.2.2 There shall be a sufficient number of portable foam extinguishers (See *Unified interpretation of SOLAS, Chapter II-2 on the number and arrangement of portable fire extinguishers on board ships (MSC.1/Circ.1275 and MSC.1/Circ.1275/Corr.1)*) or equivalent which shall be so located that no point in the space is more than 10 m walking distance from an extinguisher and that there are at least two such extinguishers in each such space, except that such extinguishers shall not be required in addition to any provided in compliance with 10.5.1.2.2.

10.5.4 Other machinery spaces

10.5.4.1 Where, in the opinion of the Register, a fire hazard exists in any machinery space for which no specific provisions for fire-extinguishing appliances are prescribed in 10.5.1, 10.5.2 and 10.5.3, there shall be provided in, or adjacent to, that space such a number of approved portable fire ex-

tinguishers or other means of fire extinction as the Register may deem sufficient.

10.5.5 Additional requirements for passenger ships

10.5.5.1 In passenger ships carrying more than 36 passengers, each machinery space of category A shall be provided with at least two suitable water fog applicators. See 25.1.19.

10.5.6 Fixed local application fire-extinguishing systems

See *IACS UI SC176 Rev.1*.

10.5.6.1 Item 10.5.6 shall apply to passenger ships of 500 gross tonnage and above and cargo ships of 2,000 gross tonnage and above.

10.5.6.2 Machinery spaces of category A above 500 m³ in volume shall, in addition to the fixed fire-extinguishing system required in 10.5.1.1, be protected by an approved type of fixed water-based or equivalent local application fire-extinguishing system, based on the guidelines developed by IMO and adopted by the Register (see *Revised Guidelines for the approval of fixed water-based local application fire-fighting systems for use in category A machinery spaces (MSC.1/Circ.1387/Corr.1)*, *Unified interpretations of the Guidelines for the approval of fixed water-based local application fire-fighting systems (MSC/Circ.1082)* and *Unified interpretations of SOLAS Chapter II-2 (MSC.1/Circ.1276/Rev.1)*). See also *IACS UI SC217, Corr.2*. In the case of periodically unattended machinery spaces, the fire-extinguishing system shall have both automatic and manual release capabilities. In the case of continuously manned machinery spaces, the fire-extinguishing system is only required to have a manual release capability.

10.5.6.3 Fixed local application fire-extinguishing systems are to protect areas such as the following without the necessity of engine shutdown, personnel evacuation, or sealing of the spaces:

- .1 the fire hazard portions of internal combustion machinery or, for ships constructed before 1 July 2014, the fire hazard portions of internal combustion machinery used for the ship's main propulsion and power generation;
- .2 boiler fronts;
- .3 the fire hazard portions of incinerators; and
- .4 purifiers for heated fuel oil.

See *IACS UI SC198, Corr.1*.

10.5.6.4 Activation of any local application system shall give a visual and distinct audible alarm in the protected space and at continuously manned stations. The alarm shall indicate the specific system activated. The system alarm requirements described within this item are in addition to, and not a substitute for, the detection and fire alarm system required elsewhere in this part of the Rules for the classification of ships.

10.6 FIRE-EXTINGUISHING ARRANGEMENTS IN CONTROL STATIONS, ACCOMMODATION AND SERVICE SPACES

10.6.1 Sprinkler and water-spraying systems in passenger ships

10.6.1.1 Passenger ships carrying more than 36 passengers shall be equipped with an automatic sprinkler, fire detection and fire alarm system of an approved type complying with the requirements of the Section 24 in all control stations, accommodation and service spaces, including corridors and stairways. Alternatively, control stations, where water may cause damage to essential equipment, may be fitted with an approved fixed fire-extinguishing system of another type. Spaces having little or no fire risk such as voids, public toilets, carbon dioxide rooms and similar spaces need not be fitted with an automatic sprinkler system. See *IACS UI SC130 Rev.2*.

10.6.1.2 In passenger ships carrying not more than 36 passengers, when a fixed smoke detection and fire alarm system complying with the provisions of the Section 24 is provided only in corridors, stairways and escape routes within accommodation spaces, an automatic sprinkler system shall be installed in accordance with 7.5.3.2.

10.6.1.3 A fixed pressure water-spraying fire-extinguishing system complying with the provisions of the Section 24 shall be installed on cabin balconies of ships to which 5.3.4 applies, where furniture and furnishings on such balconies are not as defined in 3.1.2.40.1, 3.1.2.40.2, 3.1.2.40.3, 3.1.2.40.6 and 3.1.2.40.7. See *Guidelines for the approval of fixed pressure water-spraying and water-based fire-extinguishing systems for cabin balconies (MSC.1/Circ.1268)*.

10.6.2 Sprinkler systems for cargo ships

10.6.2.1 In cargo ships in which method IIC specified in 9.2.3.1.1.2 is adopted, an automatic sprinkler, fire detection and fire alarm system shall be fitted in accordance with the requirements in 7.5.5.2.

10.6.3 Spaces containing flammable liquid

10.6.3.1 Paint lockers shall be protected by:

- .1 a carbon dioxide system, designed to give a minimum volume of free gas equal to 40% of the gross volume of the protected space;
- .2 a dry powder system, designed for at least 0.5 kg powder/m³;
- .3 a water spraying or sprinkler system, designed for 5 l/m² min. Water spraying systems may be connected to the fire main of the ship; or
- .4 a system providing equivalent protection, as determined by the *Register*.

In all cases, the system shall be operable from outside the protected space.

10.6.3.2 Flammable liquid lockers shall be protected by an appropriate fire-extinguishing arrangement approved by the *Register*. See *IACS UI SC199*.

10.6.3.3 For lockers of a deck area of less than 4 m², which do not give access to accommodation spaces, a portable carbon dioxide fire extinguisher sized to provide a minimum volume of free gas equal to 40% of the gross volume of the space may be accepted in lieu of a fixed system. A discharge port shall be arranged in the locker to allow the discharge of the extinguisher without having to enter into the protected space. The required portable fire extinguisher shall be stowed adjacent to the port. Alternatively, a port or hose connection may be provided to facilitate the use of fire main water.

10.6.4 Deep-fat cooking equipment

10.6.4.1 Deep-fat cooking equipment installed in enclosed spaces or on open decks shall be fitted with the following:

- .1 an automatic or manual fire-extinguishing system tested to an international standard acceptable to the *Register*; (see *recommendations by the International Organization for Standardization, in particular publication ISO 15371:2009, Ships and marine technology – Fire-extinguishing systems for protection of galley cooking equipment*.) See *MSC.1/Circ.1433*.
- .2 a primary and backup thermostat with an alarm to alert the operator in the event of failure of either thermostat;
- .3 arrangements for automatically shutting off the electrical power upon activation of the fire-extinguishing system;
- .4 an alarm for indicating operation of the fire-extinguishing system in the galley where the equipment is installed; and
- .5 controls for manual operation of the fire-extinguishing system which are clearly labelled for ready use by the crew.

10.7 FIRE-EXTINGUISHING ARRANGEMENTS IN CARGO SPACES

10.7.1 Fixed gas fire-extinguishing systems for general cargo

10.7.1.1 Except as provided for in 10.7.2, the cargo spaces of passenger ships of 1,000 GT and upwards shall be protected by a fixed carbon dioxide or inert gas fire-extinguishing system complying with the provisions of the Section 24 or by a fixed high-expansion foam fire-extinguishing system which gives equivalent protection.

10.7.1.2 Where it is shown to the satisfaction of the *Register* that a passenger ship is engaged on voyages of such short duration that it would be unreasonable to apply the requirements of 10.7.1.1 and also in ships of less than 1,000 gross tonnage, the arrangements in cargo spaces shall be to the satisfaction of the *Register*, provided that the ship is fitted with steel hatch covers and effective means of closing all ventilators and other openings leading to the cargo spaces.

10.7.1.3 Except for ro-ro and vehicle spaces, cargo spaces on cargo ships of 2,000 GT and upwards shall be protected by a fixed carbon dioxide or inert gas fire-extinguishing system complying with the provisions of the Section 24, or by a fire-extinguishing system which gives equivalent protection.

See *IACS UI SC48 Rev.1*. See also *IACS UI SC250, Corr.2* and *MSC.1/Circ.1456*.

10.7.1.4 The *Register* may exempt from the requirements of 10.7.1.3 and 10.7.2 cargo spaces of any cargo ship if constructed, and solely intended, for the carriage of ore, coal, grain, unseasoned timber, non-combustible cargoes or cargoes which, in the opinion of the *Register*, constitute a low fire risk (see *IMSBC Code (resolution MSC.268(85))*), as amended, appendix 1, entry for coal, and to the Lists of solid bulk cargoes for which a fixed gas fire-extinguishing system may be exempted or for which a fixed gas fire-extinguishing system is ineffective (*MSC.1/Circ.1395/Rev.6*). Such exemptions may be granted only if the ship is fitted with steel hatch covers and effective means of closing all ventilators and other openings leading to the cargo spaces. When such exemptions are granted, the *Register* shall issue an Exemption Certificate, irrespective of the date of construction of the ship concerned and shall ensure that the list of cargoes the ship is permitted to carry is attached to the Exemption Certificate. See *IACS UI SC197 Rev.2*.

10.7.2 Fixed gas fire-extinguishing systems for dangerous goods

A ship engaged in the carriage of dangerous goods in any cargo spaces shall be provided with a fixed carbon dioxide or inert gas fire-extinguishing system complying with the provisions of the Section 24 or with a fire-extinguishing system which, in the opinion of the *Register*, gives equivalent protection for the cargoes carried.

See *IACS UI SC49, Rev.3* and *IACS UI SC159 Rev.1 Corr.1*. See also *IACS UI SC250, Corr.2* and *MSC.1/Circ.1456*.

10.7.3 Firefighting for ships designed to carry containers on or above the weather deck

10.7.3.1 Ships shall carry, in addition to the equipment and arrangements required by 10.1 and 10.2, at least one water mist lance.

10.7.3.1.1 The water mist lance shall consist of a tube with a piercing nozzle which is capable of penetrating a container wall and producing water mist inside a confined space (container, etc.) when connected to the fire main.

10.7.3.2 Ships designed to carry five or more tiers of containers on or above the weather deck shall carry, in addition to the requirements of 10.7.3.1, mobile water monitors as follows:

- ships with breadth less than 30 m: at least two mobile water monitors;
- ships with breadth of 30 m or more: at least four mobile water monitors.

For mobile water monitors see *Guidelines for the design, performance, testing and approval of mobile water monitors used for the protection of on-deck cargo areas of ships designed and constructed to carry five or more tiers of containers on or above the weather deck (MSC.1/Circ.1472)*.

10.7.3.2.1 The mobile water monitors, all necessary hoses, fittings and required fixing hardware shall be kept ready for use in a location outside the cargo space area not likely to be cut-off in the event of a fire in the cargo spaces.

10.7.3.2.2 A sufficient number of fire hydrants shall be provided such that:

- .1 all provided mobile water monitors can be operated simultaneously for creating effective water barriers forward and aft of each container bay;
- .2 the two jets of water required by 10.2.1.5.1 can be supplied at the pressure required by 10.2.1.6; and
- .3 each of the required mobile water monitors can be supplied by separate hydrants at the pressure necessary to reach the top tier of containers on deck.

10.7.3.2.3 The mobile water monitors may be supplied by the fire main, provided the capacity of fire pumps and fire main diameter are adequate to simultaneously operate the mobile water monitors and two jets of water from fire hoses at the required pressure values. If carrying dangerous goods, the capacity of fire pumps and fire main diameter shall also comply with 19.3.1.5, as far as applicable to on-deck cargo areas.

See *IACS UI SC270 Rev.1*. See also *MSC.1/Circ.1550*.

10.7.3.2.4 The operational performance of each mobile water monitor shall be tested during initial survey on board the ship to the satisfaction of the *Register*. The test shall verify that:

- .1 the mobile water monitor can be securely fixed to the ship structure ensuring safe and effective operation; and
- .2 the mobile water monitor jet reaches the top tier of containers with all required monitors and water jets from fire hoses operated simultaneously.

10.8 CARGO TANK PROTECTION

See *IACS UI SC169, Rev.1*.

10.8.1 Fixed deck foam fire-extinguishing systems

10.8.1.1 For tankers of 20,000 tonnes deadweight and upwards, a fixed deck foam fire-extinguishing system shall be provided complying with the provisions of the Section 24, except that, in lieu of the above, the *Register*, after having given consideration to the ship's arrangement and equipment, may accept other fixed installations if they afford protection equivalent to the above. The requirements for alternative fixed installations shall comply with the requirements in 10.8.1.2.

10.8.1.2 In accordance with 10.8.1.1, where the *Register* accepts an equivalent fixed installation in lieu of the fixed deck foam fire-extinguishing system, the installation shall:

- .1 be capable of extinguishing spill fires and also preclude ignition of spilled oil not yet ignited; and
- .2 be capable of combating fires in ruptured tanks.

10.8.1.3 Tankers of less than 20,000 tonnes deadweight shall be provided with a deck foam fire-extinguishing system complying with the requirements of the Section 24.

10.9 PROTECTION OF CARGO PUMP-ROOMS IN TANKERS

10.9.1 Fixed fire-extinguishing systems

Each cargo pump-room shall be provided with one of the following fixed fire-extinguishing systems operated from a readily accessible position outside the pump-room. Cargo pump-rooms shall be provided with a system suitable for machinery spaces of category A.

10.9.1.1 A carbon dioxide fire-extinguishing system complying with the provisions of the Section 24 and with the following:

- .1 the alarms giving audible warning of the release of fire-extinguishing medium shall be safe for use in a flammable cargo vapour/air mixture; and
- .2 a notice shall be exhibited at the controls stating that, due to the electrostatic ignition hazard, the system is to be used only for fire extinguishing and not for inerting purposes.

10.9.1.2 A high-expansion foam fire-extinguishing system complying with the provisions of the Section 24, provided that the foam concentrate supply is suitable for extinguishing fires involving the cargoes carried.

10.9.1.3 A fixed pressure water-spraying fire-extinguishing system complying with the provisions of the Section 24.

10.9.1.4 Pump room alarms shall be in compliance with following requirements (IACS UR F5 Rev.1).

Where audible alarms are fitted to warn of the release of fire extinguishing medium into pump rooms, they may be of the pneumatic type or electric type.

- (a) Pneumatically operated alarms
In cases where the periodic testing of such alarms is required, CO₂ operated alarms should not be used owing to the possibility of the generation of static electricity in the CO₂ cloud. Air operated alarms may be used provided the air supply is clean and dry.
- (b) Electrically operated alarms
When electrically operated alarms are used, the arrangements are to be such that the electric actuating mechanism is located outside the pump room except where the alarms are certified intrinsically safe.

CO₂ operated alarms are not permitted.

10.9.2 Quantity of fire-extinguishing medium

10.9.2.1 Where the fire-extinguishing medium used in the cargo pump-room system is also used in systems serving other spaces, the quantity of medium provided or its delivery rate need not be more than the maximum required for the largest compartment.

10.10 FIRE-FIGHTER'S OUTFITS

10.10.1 Types of firefighter's outfits

10.10.1.1 Fire-fighter's outfits shall comply with the Section 24.

10.10.1.2 Self-contained compressed air breathing apparatus of fire-fighter's outfits shall comply with 24.3.2.1.2.2 by 1 July 2019.

10.10.2 Number of fire-fighter's outfits

10.10.2.1 Ships shall carry at least two fire-fighter's outfits.

10.10.2.2 In addition, in passenger ships there shall be provided:

- .1 for every 80 m, or part thereof, of the aggregate of the lengths of all passenger spaces and service spaces on the deck which carries such spaces or, if there is more than one such deck, on the deck which has the largest aggregate of such lengths, two fire-fighter's outfits and, in addition, two sets of personal equipment, each set comprising the items stipulated in the Section 24. In passenger ships carrying more than 36 passengers, two additional fire-fighter's outfits shall be provided for each main vertical zone. However, for stairway enclosures which constitute individual main vertical zones and for the main vertical zones in the fore or aft end of a ship which do not contain spaces of categories (6), (7), (8) or (12) defined in 9.2.2.3, no additional fire-fighter's outfits are required; and
- .2 on ships carrying more than 36 passengers, for each pair of breathing apparatus, one water fog applicator which shall be stored adjacent to such apparatus.

10.10.2.3 In addition, in tankers, two fire-fighter's outfits shall be provided.

10.10.2.4 The *Register* may require additional sets of personal equipment and breathing apparatus, having due regard to the size and type of the ship.

10.10.2.5 Two spare charges shall be provided for each required breathing apparatus. Passenger ships carrying not more than 36 passengers and cargo ships that are equipped with suitably located means for fully recharging the air cylinders free from contamination need carry only one spare charge for each required apparatus. In passenger ships carrying more than 36 passengers, at least two spare charges for each breathing apparatus shall be provided.

10.10.2.6 Passenger ships carrying more than 36 passengers shall be fitted with a suitably located means for fully recharging breathing air cylinders, free from contamination. The means for recharging shall be either:

- .1 breathing air compressors supplied from the main and emergency switchboard, or independently driven, with a minimum ca-

- capacity of 60 l/min per required breathing apparatus, not to exceed 420 l/min; or
- .2 self-contained high-pressure storage systems of suitable pressure to recharge the breathing apparatus used on board, with a capacity of at least 1,200 l per required breathing apparatus, not to exceed 50,000 l of free air.

10.10.3 Storage of fire-fighter's outfits

10.10.3.1 The fire-fighter's outfits or sets of personal equipment shall be kept ready for use in an easily accessible location that is permanently and clearly marked and, where more than one fire-fighter's outfit or more than one set of personal equipment is carried, they shall be stored in widely separated positions.

10.10.3.2 In passenger ships, at least two fire-fighter's outfits and, in addition, one set of personal equipment shall be available at any one position. At least two fire-fighter's outfits shall be stored in each main vertical zone.

10.10.4 Fire-fighter's communication

10.10.4.1 A minimum of two two-way portable radiotelephone apparatus for each fire party for fire-fighter's communication shall be carried on board. Those two-way portable radiotelephone apparatus shall be of an explosion-proof type or intrinsically safe. See *MSC.1/Circ.1616* and *IACS UI SC291*.

11 STRUCTURAL INTEGRITY

11.1 GENERAL REQUIREMENTS

11.1.1 The purpose of this Section is to maintain structural integrity of the ship, preventing partial or whole collapse of the ship structures due to strength deterioration by heat. For this purpose, materials used in the ships' structure shall ensure that the structural integrity is not degraded due to fire.

11.2 MATERIAL OF HULL, SUPERSTRUCTURES, STRUCTURAL BULKHEADS, DECKS AND DECKHOUSES

11.2.1 The hull, superstructures, structural bulkheads, decks and deckhouses shall be constructed of steel or other equivalent material. For the purpose of applying the definition of steel or other equivalent material as given in 3.1.2.43, the "applicable fire exposure" shall be according to the integrity and insulation standards given in tables 9.1 to 9.4. For example, where divisions such as decks or sides and ends of deckhouses are permitted to have "B-0" fire integrity, the "applicable fire exposure" shall be half an hour.

11.2.2 "Light-weight constructions" (honeycomb type, etc.) of steel or equivalent material may be used as non load-bearing internal "A" class division in accommodation and service spaces provided they have successfully passed the relevant standard fire test according to the FTP Code.

These "light-weight constructions" shall not be used as an integral part of main fire zone bulkheads and stairway enclosures on passenger ships (see *MSC/Circ.1005* and *MSC/Circ.1120*).

11.3 STRUCTURE OF ALUMINIUM ALLOY

11.3.1 Unless otherwise specified in 11.2, in cases where any part of the structure is of aluminium alloy, the following shall apply:

- .1 the insulation of aluminium alloy components of "A" or "B" class divisions, except structure which, in the opinion of the *Register*, is non-load-bearing, shall be such that the temperature of the structural core does not rise more than 200°C above the ambient temperature at any time during the applicable fire exposure to the standard fire test; and
- .2 special attention shall be given to the insulation of aluminium alloy components of columns, stanchions and other structural members required to support lifeboat and liferaft stowage, launching and embarkation areas, and "A" and "B" class divisions to ensure:
 - .2.1 that for such members supporting lifeboat and liferaft areas and "A" class divisions, the temperature rise limitation specified in

11.3.1 shall apply at the end of one hour; and

- .2.2 that for such members required to support "B" class divisions, the temperature rise limitation specified in 11.3.1 shall apply at the end of half an hour.
- .3 in cargo ships of less than 500 gross tonnage, the temperature rise limitation required in paragraphs .1 and .2 above may apply at the end of half an hour.

11.3.2 Fire resisting divisions having a structural core of aluminium alloy and separating adjacent spaces, each containing combustible materials, shall be insulated on both sides of the structural core.

Non-load-bearing fire divisions need not be provided with fire insulation on the side of the space not containing combustible materials.

In any case, "A" class decks having an aluminium alloy core shall be fire insulated from below.

11.4 MACHINERY SPACES OF CATEGORY A

11.4.1 Crowns and casings

11.4.1.1 Crowns, casings and skylights of machinery spaces of category A shall be of steel construction and shall be insulated as required by tables 9.5 and 9.7, as appropriate.

11.4.2 Floor plating

11.4.2.1 The floor plating of normal passageways in machinery spaces of category A shall be made of steel.

11.5 MATERIALS OF OVERBOARD FITTINGS

11.5.1 Materials readily rendered ineffective by heat shall not be used for overboard scuppers, sanitary discharges, and other outlets which are close to the waterline and where the failure of the material in the event of fire would give rise to danger of flooding.

11.6 PROTECTION OF CARGO TANK STRUCTURE AGAINST PRESSURE OR VACUUM IN TANKERS

11.6.1 General

The venting arrangements shall be so designed and operated as to ensure that neither pressure nor vacuum in cargo tanks shall exceed design parameters and be such as to provide for:

- .1 the flow of the small volumes of vapour, air or inert gas mixtures caused by thermal variations in a cargo tank in all cases through pressure/vacuum valves; and
- .2 the passage of large volumes of vapour, air or inert gas mixtures during cargo loading and ballasting, or during discharging.

11.6.2 Openings for small flow by thermal variations

Openings for pressure release required by 11.6.1.1 shall:

- .1 have as great a height as is practicable above the cargo tank deck to obtain maximum dispersal of flammable vapours, but in no case less than 2 m above the cargo tank deck; and
- .2 be arranged at the furthest distance practicable, but not less than 5 m, from the nearest air intakes and openings to enclosed spaces containing a source of ignition and from deck machinery and equipment which may constitute an ignition hazard. Anchor windlass and chain locker openings constitute an ignition hazard. See *IACS UI SC70, Rev.4, Corr.1*.

The openings shall be arranged in accordance with 4.5.3.4.1.

See *MSC.1/Circ.1459*.

11.6.3 Safety measures in cargo tanks**11.6.3.1 Preventive measures against liquid rising in the venting system**

Provisions shall be made to guard against liquid rising in the venting system to a height which would exceed the design head of cargo tanks. This shall be accomplished by high-level alarms or overflow control systems or other equivalent means, together with independent gauging devices and cargo tank filling procedures. For the purposes of this Section, spill valves are not considered equivalent to an overflow system.

11.6.3.2 Secondary means for pressure/vacuum relief

A secondary means of allowing full flow relief of vapour, air or inert gas mixtures shall be provided to prevent over-pressure or under-pressure in the event of failure of the arrangements in 11.6.1.2. In addition, the secondary means shall be capable of preventing over-pressure or under-pressure in the event of damage to, or inadvertent closing of, the means of isolation required in 4.5.3.2.2.

Alternatively, pressure sensors may be fitted in each tank protected by the arrangement required in 11.6.1.2, with a monitoring system in the ship's cargo control room or the position from which cargo operations are normally carried out. Such monitoring equipment shall also provide an alarm facility which is activated by detection of over-pressure or under-pressure conditions within a tank. See *IACS UI SC140 Rev.3*.

11.6.3.3 Bypasses in vent mains

Pressure/vacuum valves required by 11.6.1.1 may be provided with a bypass arrangement when they are located in a vent main or masthead riser. Where such an arrangement is provided there shall be suitable indicators to show whether the bypass is open or closed.

11.6.3.4 Pressure/vacuum-breaking devices

11.6.3.4.1 One or more pressure/vacuum-breaking devices shall be provided to prevent the cargo tanks from being subject to:

- .1 a positive pressure, in excess of the test pressure of the cargo tank, if the cargo were to be loaded at the maximum rated capacity and all other outlets are left shut; and
- .2 a negative pressure in excess of 700 mm water gauge if the cargo were to be discharged at the maximum rated capacity of the cargo pumps and the inert gas blowers were to fail.

Such devices shall be installed on the inert gas main unless they are installed in the venting system required by 4.5.3.1 or on individual cargo tanks. The location and design of the devices shall be in accordance with 4.5.3 and 11.6.

11.6.4 Size of vent outlets

11.6.4.1 Vent outlets for cargo loading, discharging and ballasting required by 11.6.1.2 shall be designed on the basis of the maximum designed loading rate multiplied by a factor of at least 1.25 to take account of gas evolution, in order to prevent the pressure in any cargo tank from exceeding the design pressure. The master shall be provided with information regarding the maximum permissible loading rate for each cargo tank and, in the case of combined venting systems, for each group of cargo tanks.

12 NOTIFICATION OF CREW AND PASSENGERS

12.1 GENERAL REQUIREMENTS

12.1.1 The purpose of this Section is to notify crew and passengers of a fire for safe evacuation. For this purpose, a general emergency alarm system and a public address system shall be provided.

12.2 GENERAL EMERGENCY ALARM SYSTEM

12.2.1 A general emergency alarm system required by other Parts of the Rules for the classification of ships shall be used for notifying crew and passengers of a fire.

12.3 PUBLIC ADDRESS SYSTEMS IN PASSENGER SHIPS

12.3.1 A public address system or other effective means of communication complying with the requirements of other Parts of the Rules for the classification of ships shall be available throughout the accommodation and service spaces and control stations and open decks.

See Recommendation on performance standards for public address systems on passenger ships, including cabling (MSC/Circ.808).

13 MEANS OF ESCAPE

13.1 PURPOSE

13.1.1 The purpose of this Section is to provide means of escape so that persons on board can safely and swiftly escape to the lifeboat and liferaft embarkation deck. For this purpose, the following functional requirements shall be met:

- .1 safe escape routes shall be provided;
- .2 escape routes shall be maintained in a safe condition, clear of obstacles; and
- .3 additional aids for escape shall be provided as necessary to ensure accessibility, clear marking, and adequate design for emergency situations.

See *IACS UI SC247* and *MSC.1/Circ.1456*.

13.2 GENERAL REQUIREMENTS

13.2.1 Unless expressly provided otherwise in this Section, at least two widely separated and ready means of escape shall be provided from all spaces or groups of spaces.

13.2.2 Lifts shall not be considered as forming one of the means of escape as required by this Section.

13.3 MEANS OF ESCAPE FROM CONTROL STATIONS, ACCOMMODATION SPACES AND SERVICE SPACES

13.3.1 General requirements

13.3.1.1 Stairways and ladders shall be so arranged as to provide ready means of escape to the lifeboat and liferaft embarkation deck from passenger and crew accommodation spaces and from spaces in which the crew is normally employed, other than machinery spaces.

13.3.1.2 Unless expressly provided otherwise in this Section, a corridor, lobby, or part of a corridor from which there is only one route of escape shall be prohibited. Dead-end corridors used in service areas which are necessary for the practical utility of the ship, such as fuel oil stations and athwartship supply corridors, shall be permitted, provided such dead-end corridors are separated from crew accommodation areas and are inaccessible from passenger accommodation areas. Also, a part of a corridor that has a depth not exceeding its width is considered a recess or local extension and is permitted.

13.3.1.3 All stairways in accommodation and service spaces and control stations shall be of steel frame construction except where the *Register* sanctions the use of other equivalent material.

13.3.1.4 If a radiotelegraph station has no direct access to the open deck, two means of escape from, or access to, the station shall be provided, one of which may be a porthole or window of sufficient size or other means to the satisfaction of the *Register*.

13.3.1.5 Doors in escape routes shall, in general, open in way of the direction of escape, except that:

- .1 individual cabin doors may open into the cabins in order to avoid injury to persons in the corridor when the door is opened; and
- .2 doors in vertical emergency escape trunks may open out of the trunk in order to permit the trunk to be used both for escape and for access.

13.3.2 Means of escape in passenger ships

13.3.2.1 Escape from spaces below the bulkhead deck

13.3.2.1.1 Below the bulkhead deck, two means of escape, at least one of which shall be independent of watertight doors, shall be provided from each watertight compartment or similarly restricted space or group of spaces. Exceptionally, the *Register* may dispense with one of the means of escape for crew spaces that are entered only occasionally, if the required escape route is independent of watertight doors.

13.3.2.1.2 Where the *Register* has granted dispensation under the provisions of 13.3.2.1.1, this sole means of escape shall provide safe escape. However, stairways shall not be less than 800 mm in clear width with handrails on both sides.

13.3.2.2 Escape from spaces above the bulkhead deck

Above the bulkhead deck there shall be at least two means of escape from each main vertical zone or similarly restricted space or group of spaces, at least one of which shall give access to a stairway forming a vertical escape.

13.3.2.3 Direct access to stairway enclosures

Stairway enclosures in accommodation and service spaces shall have direct access from the corridors and be of a sufficient area to prevent congestion, having in view the number of persons likely to use them in an emergency. Within the perimeter of such stairway enclosures, only public toilets, lockers of non-combustible material providing storage for non-hazardous safety equipment and open information counters are permitted. Only corridors, lifts, public toilets, special category spaces and open ro-ro spaces to which any passengers carried can have access, other escape stairways required by 13.3.2.4.1 and external areas are permitted to have direct access to these stairway enclosures. Public spaces may also have direct access to stairway enclosures except for the backstage of a theatre. Small corridors or "lobbies" used to separate an enclosed stairway from galleys or main laundries may have direct access to the stairway provided they have a minimum deck area of 4.5 m², a width of no less than 900 mm and contain a fire hose station. See *MSC/Circ.1037*.

13.3.2.4 Details of means of escape

13.3.2.4.1 At least one of the means of escape required by 13.3.2.1.1 and 13.3.2.2 shall consist of a readily accessible enclosed stairway, which shall provide continuous fire shelter from the level of its origin to the appropriate lifeboat and liferaft embarkation decks, or to the uppermost weather deck if the embarkation deck does not extend to the main vertical zone being considered. In the latter case, direct access to the embarkation deck by way of external open stairways and pas-

sageways shall be provided and shall have emergency lighting as required in the *Rules for the classification of ships, Part 12 – Electrical equipment*, 19.1 and slip-free surfaces underfoot. Boundaries facing external open stairways and passageways forming part of an escape route and boundaries in such a position that their failure during a fire would impede escape to the embarkation deck shall have fire integrity, including insulation values, in accordance with tables 9.1 to 9.4, as appropriate.

13.3.2.4.2 Protection of access from the stairway enclosures to the lifeboat and liferaft embarkation areas shall be provided either directly or through protected internal routes which have fire integrity and insulation values for stairway enclosures as determined by tables 9.1 to 9.4, as appropriate.

13.3.2.4.3 Stairways serving only a space and a balcony in that space shall not be considered as forming one of the required means of escape.

13.3.2.4.4 Each level within an atrium shall have two means of escape, one of which shall give direct access to an enclosed vertical means of escape meeting the requirements of 13.3.2.4.1.

13.3.2.4.5 The widths, number and continuity of escapes shall be in accordance with the requirements in the Section 24.

13.3.2.4.6 For passenger ships of less than 500 gross tonnage, carrying not more than 36 passengers, not engaged neither in international navigation nor on domestic line service, navigating only in summer period (April 1st to October 31st) in navigation area 6, 7 or 8, hatch being secondary means of escape shall have clear opening at least 600 x 600 mm.

13.3.2.5 Marking of escape routes

13.3.2.5.1 In addition to the emergency lighting required by other Sections and the *Rules for the classification of ships, Part 12 – Electrical equipment*, 19.1, the means of escape, including stairways and exits, shall be marked by lighting or photoluminescent strip indicators placed not more than 300 mm above the deck at all points of the escape route, including angles and intersections. The marking must enable passengers to identify the routes of escape and readily identify the escape exits. If electric illumination is used, it shall be supplied by the emergency source of power and it shall be so arranged that the failure of any single light or cut in a lighting strip will not result in the marking being ineffective. Additionally, escape route signs and fire equipment location markings shall be of photoluminescent material or marked by lighting. The *Register* shall ensure that such lighting or photoluminescent equipment has been evaluated, tested and applied in accordance with the Section 24.

See Escape route signs and equipment location markings (IMO Res. A.1116(30)).

13.3.2.5.2 In passenger ships carrying more than 36 passengers, the requirements of the 13.3.2.5.1 shall also apply to the crew accommodation areas.

13.3.2.5.3 In lieu of the escape route lighting system required by 13.3.2.5.1, alternative evacuation guidance systems may be accepted if approved by the *Register* based on the guidelines developed by IMO, see *Functional requirements and performance standards for the assessment of evacuation guidance systems (MSC/Circ.1167)* and *Interim guidelines for the testing, approval and maintenance of evacuation guidance*

systems used as an alternative to low-location lighting systems (MSC/Circ.1168).

13.3.2.6 Normally locked doors that form part of an escape route

13.3.2.6.1 Cabin and stateroom doors shall not require keys to unlock them from inside the room. Neither shall there be any doors along any designated escape route which require keys to unlock them when moving in the direction of escape.

13.3.2.6.2 Escape doors from public spaces that are normally latched shall be fitted with a means of quick release. Such means shall consist of a door-latching mechanism incorporating a device that releases the latch upon the application of a force in the direction of escape flow. Quick release mechanisms shall be designed and installed to the satisfaction of the *Register* and, in particular:

- .1 consist of bars or panels, the actuating portion of which extends across at least one half of the width of the door leaf, at least 760 mm and not more than 1,120 mm above the deck;
- .2 cause the latch to release when a force not exceeding 67 N is applied; and
- .3 not be equipped with any locking device, set screw or other arrangement that prevents the release of the latch when pressure is applied to the releasing device.

13.3.2.7 Evacuation analysis for passenger ships

Refer to the Revised Guidelines on evacuation analysis for new and existing passenger ships (*MSC.1/Circ.1533*), as may be amended.

13.3.2.7.1 Escape routes shall be evaluated by an evacuation analysis early in the design process. This analysis shall apply to:

- .1 ro-ro passenger ships constructed on or after 1 July 1999; and
- .2 other passenger ships constructed on or after 1 January 2020 carrying more than 36 passengers.

13.3.2.7.2 The analysis shall be used to identify and eliminate, as far as practicable, congestion which may develop during an abandonment, due to normal movement of passengers and crew along escape routes, including the possibility that crew may need to move along these routes in a direction opposite to the movement of passengers. In addition, the analysis shall be used to demonstrate that escape arrangements are sufficiently flexible to provide for the possibility that certain escape routes, assembly stations, embarkation stations or survival craft may not be available as a result of a casualty.

13.3.3 Means of escape in cargo ships

13.3.3.1 General

At all levels of accommodation there shall be provided at least two widely separated means of escape from each restricted space or group of spaces.

13.3.3.2 Escape from spaces below the lowest open deck

Below the lowest open deck the main means of escape shall be a stairway and the second escape may be a trunk or a stairway. See *MSC.1/Circ.1511* and *IACS UI SC278*.

13.3.3.3 Escape from spaces above the lowest open deck

Above the lowest open deck the means of escape shall be stairways or doors to an open deck or a combination thereof. See *MSC.1/Circ.1511* and *IACS UI SC278*.

13.3.3.4 Dead-end corridors

No dead-end corridors having a length of more than 7 m shall be accepted. Where used, dead-end corridors shall be separated from the passenger and special personnel accommodation areas and shall be restricted, as far as practicable, to service areas which are necessary for the practical utility of the ship.

13.3.3.5 Width and continuity of escape routes

The width, number and continuity of escape routes shall be in accordance with the requirements in the Section 24.

13.3.3.6 Dispensation from two means of escape

Exceptionally, the *Register* may dispense with one of the means of escape, for crew spaces that are entered only occasionally, if the required escape route is independent of watertight doors.

13.3.4 Emergency escape breathing devices

13.3.4.1 Emergency escape breathing devices shall comply with the Section 24. Spare emergency escape breathing devices shall be kept on board.

13.3.4.2 All ships shall carry at least two emergency escape breathing devices within accommodation spaces.

13.3.4.3 In all passenger ships, at least two emergency escape breathing devices shall be carried in each main vertical zone.

13.3.4.4 In all passenger ships carrying more than 36 passengers, two emergency escape breathing devices, in addition to those required in 13.3.4.3 above, shall be carried in each main vertical zone.

13.3.4.5 However, 13.3.4.3 and 13.3.4.4 do not apply to stairway enclosures which constitute individual main vertical zones and to the main vertical zones in the fore or aft end of a ship which do not contain spaces of categories (6), (7), (8) or (12) as defined in 9.2.2.3.

13.4 MEANS OF ESCAPE FROM MACHINERY SPACES**13.4.1 Means of escape on passenger ships**

Means of escape from each machinery space in passenger ships shall comply with the following provisions.

See *MSC.1/Circ.1511* and *IACS UI SC276*.

13.4.1.1 Escape from spaces below the bulkhead deck

Where the space is below the bulkhead deck, the two means of escape shall consist of either:

- .1 two sets of steel ladders, as widely separated as possible, leading to doors in the upper part of the space, similarly separated and from which access is provided to the appropriate lifeboat and liferaft embarkation decks. One of these ladders shall be located within a protected enclosure that satisfies 9.2.2.3, category (2), or 9.2.2.4, category (4), as appropriate, from the lower part of the space it serves to a safe position outside the space. Self-closing fire doors of the same fire integrity standards shall be fitted in the enclosure. The ladder shall be fixed in such a way that heat is not transferred into the enclosure through non-insulated fixing points. The protected enclosure shall have minimum internal dimensions of at least 800 mm x 800 mm, and shall have emergency lighting provisions; or
- .2 one steel ladder leading to a door in the upper part of the space from which access is provided to the embarkation deck and additionally, in the lower part of the space and in a position well separated from the ladder referred to, a steel door capable of being operated from each side and which provides access to a safe escape route from the lower part of the space to the embarkation deck.

13.4.1.2 Escape from spaces above the bulkhead deck

Where the space is above the bulkhead deck, the two means of escape shall be as widely separated as possible and the doors leading from such means of escape shall be in a position from which access is provided to the appropriate lifeboat and liferaft embarkation decks. Where such means of escape require the use of ladders, these shall be of steel.

13.4.1.3 Dispensation from two means of escape

In a ship of less than 1,000 gross tonnage, the *Register* may dispense with one of the means of escape, due regard being paid to the width and disposition of the upper part of the space. In a ship of 1,000 gross tonnage and above, the *Register* may dispense with one means of escape from any such space, including a normally unattended auxiliary machinery space, so long as either a door or a steel ladder provides a safe escape route to the embarkation deck, due regard being paid to the nature and location of the space and whether persons are normally employed in that space. In the steering gear space, a second means of escape shall be provided when the emergency steering position is located in that space unless there is direct access to the open deck.

See *IACS UI SC41 Rev.2*.

One of the escape routes from the machinery spaces where the crew is normally employed shall avoid direct access to any special category space.

13.4.1.4 Escape from machinery control rooms

Two means of escape shall be provided from a machinery control room located within a machinery space, at least one of which will provide continuous fire shelter to a safe position outside the machinery space. See *MSC.1/Circ.1511*.

13.4.1.5 Inclined ladders and stairways

All inclined ladders/stairways fitted to comply with 13.4.1.1 with open treads in machinery spaces being part of or providing access to escape routes but not located within a protected enclosure shall be made of steel. Such ladders/stairways shall be fitted with steel shields attached to their undersides, such as to provide escaping personnel protection against heat and flame from beneath.

13.4.1.6 Escape from main workshops within machinery spaces

Two means of escape shall be provided from the main workshop within a machinery space. At least one of these escape routes shall provide a continuous fire shelter to a safe position outside the machinery space.

See *MSC.1/Circ.1511*.

13.4.2 Means of escape on cargo ships

Means of escape from each machinery space in cargo ships shall comply with the following provisions.

See *MSC.1/Circ.1511* and *IACS UI SC277*.

13.4.2.1 Escape from machinery spaces of category A

Except as provided in 13.4.2.2, two means of escape shall be provided from each machinery space of category A. In particular, one of the following provisions shall be complied with:

- .1 two sets of steel ladders, as widely separated as possible, leading to doors in the upper part of the space, similarly separated and from which access is provided to the open deck. One of these ladders shall be located within a protected enclosure that satisfies 9.2.3.3, category (4), from the lower part of the space it serves to a safe position outside the space. Self-closing fire doors of the same fire integrity standards shall be fitted in the enclosure. The ladder shall be fixed in such a way that heat is not transferred into the enclosure through non-insulated fixing points. The enclosure shall have minimum internal dimensions of at least 800 mm x 800 mm, and shall have emergency lighting provisions; or
- .2 one steel ladder leading to a door in the upper part of the space from which access is provided to the open deck and, additionally, in the lower part of the space and in a position well separated from the ladder referred to, a steel door capable of being operated from each side and which provides access to a safe escape route from the lower part of the space to the open deck.

13.4.2.2 Dispensation from two means of escape

In a ship of less than 1,000 gross tonnage, the *Register* may dispense with one of the means of escape required under 13.4.2.1, due regard being paid to the dimension and disposition of the upper part of the space. In addition, the means of escape from machinery spaces of category A need not comply with the requirement for an enclosed fire shelter listed in 13.4.2.1.1. In the steering gear space, a second means of escape shall be provided when the emergency steering position is located in that space unless there is direct access to the open deck. See *IACS UI SC269 Rev.1*.

13.4.2.3 Escape from machinery spaces other than those of category A

From machinery spaces other than those of category A, two escape routes shall be provided except that a single escape route may be accepted for spaces that are entered only occasionally and for spaces where the maximum travel distance to the door is 5 m or less. See *IACS UI SC269 Rev.1*.

13.4.2.4 Inclined ladders and stairways

All inclined ladders/stairways fitted to comply with 13.4.2.1 with open treads in machinery spaces being part of or providing access to escape routes but not located within a protected enclosure shall be made of steel. Such ladders/stairways shall be fitted with steel shields attached to their undersides, such as to provide escaping personnel protection against heat and flame from beneath.

13.4.2.5 Escape from machinery control rooms in machinery spaces of category "A"

Two means of escape shall be provided from the machinery control room located within a machinery space. At least one of these escape routes shall provide a continuous fire shelter to a safe position outside the machinery space.

See *MSC.1/Circ.1511*.

13.4.2.6 Escape from main workshops in machinery spaces of category "A"

Two means of escape shall be provided from the main workshop within a machinery space. At least one of these escape routes shall provide a continuous fire shelter to a safe position outside the machinery space.

See *MSC.1/Circ.1511*.

13.4.3 Emergency escape breathing devices

13.4.3.1 On all ships, within the machinery spaces, emergency escape breathing devices shall be situated ready for use at easily visible places, which can be reached quickly and easily at any time in the event of fire. The location of emergency escape breathing devices shall take into account the layout of the machinery space and the number of persons normally working in the spaces. See *Guidelines for the performance, location, use and care of emergency escape breathing devices (MSC/Circ.849)*.

13.4.3.2 The number and location of these devices shall be indicated in the fire control plan required in 15.2.4.

13.4.3.3 Emergency escape breathing devices shall comply with the Section 24.

13.5 MEANS OF ESCAPE ON PASSENGER SHIPS FROM SPECIAL CATEGORY AND OPEN RO-RO SPACES TO WHICH ANY PASSENGERS CARRIED CAN HAVE ACCESS

13.5.1 In special category and open ro-ro spaces to which any passengers carried can have access, the number and locations of the means of escape both below and above the bulkhead deck shall be to the satisfaction of the *Register* and, in general, the safety of access to the embarkation deck shall be at least equivalent to that provided for under 13.3.2.1.1, 13.3.2.2, 13.3.2.4.1 and 13.3.2.4.2. Such spaces shall be provided with designated walkways to the means of escape with a breadth of at least 600 mm. The parking arrangements for the vehicles shall maintain the walkways clear at all times.

13.5.2 One of the escape routes from the machinery spaces where the crew is normally employed shall avoid direct access to any special category space.

13.5.3 Indicators shall be provided on the navigating bridge which shall indicate when any fire door leading to or from the special category spaces is closed.

13.6 MEANS OF ESCAPE FROM RO-RO SPACES

13.6.1 At least two means of escape shall be provided in ro-ro spaces where the crew are normally employed. The escape routes shall provide a safe escape to the lifeboat and liferaft embarkation decks and shall be located at the fore and aft ends of the space.

See *MSC.1/Circ.1505*.

13.7 ADDITIONAL REQUIREMENTS FOR RO-RO PASSENGER SHIPS

13.7.1 General

13.7.1.1 Escape routes shall be provided from every normally occupied space on the ship to an assembly station. These escape routes shall be arranged so as to provide the most direct route possible to the assembly station (see *Indication of the assembly stations in passenger ships (MSC/Circ.777)*), and shall be marked with symbols based on the guidelines developed by IMO and adopted by the *Register* (see *Symbols related to life-saving appliances and arrangements, resolution A.760(18), as amended by resolution MSC.82(70)*).

13.7.1.2 The escape route from cabins to stairway enclosures shall be as direct as possible, with a minimum number of changes in direction. It shall not be necessary to cross from one side of the ship to the other to reach an escape route. It shall not be necessary to climb more than two decks up or down in order to reach an assembly station or open deck from any passenger space.

13.7.1.3 External routes shall be provided from open decks, as referred to in 13.7.1.2, to the survival craft embarkation stations.

13.7.1.4 Where enclosed spaces adjoin an open deck, openings from the enclosed space to the open deck shall, where practicable, be capable of being used as an emergency exit.

13.7.1.5 Escape routes shall not be obstructed by furniture and other obstructions. With the exception of tables and chairs which may be cleared to provide open space, cabinets and other heavy furnishings in public spaces and along escape routes shall be secured in place to prevent shifting if the ship rolls or lists. Floor coverings shall also be secured in place. When the ship is under way, escape routes shall be kept clear of obstructions such as cleaning carts, bedding, luggage and boxes of goods.

13.7.2 Instruction for safe escape

13.7.2.1 Decks shall be sequentially numbered, starting with ‘1’ at the tank top or lowest deck. The numbers shall be prominently displayed at stair landings and lift lobbies. Decks may also be named, but the deck number shall always be displayed with the name.

13.7.2.2 Simple ‘mimic’ plans showing the ‘you are here’ position and escape routes marked by arrows shall be prominently displayed on the inside of each cabin door and in public spaces. The plan shall show the directions of escape and shall be properly oriented in relation to its position on the ship.

13.7.3 Strength of handrails and corridors

13.7.3.1 Handrails or other handholds shall be provided in corridors along the entire escape route so that a firm handhold is available at every step of the way, where possible, to the assembly stations and embarkation stations. Such handrails shall be provided on both sides of longitudinal corridors more than 1.8 m in width and transverse corridors more than 1 m in width. Particular attention shall be paid to the need to be able to cross lobbies, atriums and other large open spaces along escape routes. Handrails and other handholds shall be of such strength as to withstand a distributed horizontal load of 750 N/m applied in the direction of the centre of the corridor or space, and a distributed vertical load of 750 N/m applied in the downward direction. The two loads need not be applied simultaneously.

13.7.3.2 The lowest 0.5 m of bulkheads and other partitions forming vertical divisions along escape routes shall be able to sustain a load of 750 N/m to allow them to be used as walking surfaces from the side of the escape route with the ship at large angles of heel.

14 OPERATIONAL READINESS AND MAINTENANCE

14.1 PURPOSE

14.1.1 The purpose of this Section is to maintain and monitor the effectiveness of the fire safety measures the ship is provided with. For this purpose, the following functional requirements shall be met:

- .1 fire protection systems and fire-fighting systems and appliances shall be maintained ready for use; and
- .2 fire protection systems and fire-fighting systems and appliances shall be properly tested and inspected.

14.2 GENERAL REQUIREMENTS

At all times while the ship is in service, the requirements of 14.1.1 shall be complied with. A ship is not in service when:

- .1 it is in for repairs or lay-up (either at anchor or in port) or in dry-dock;
- .2 it is declared not in service by the owner or the owner's representative; and
- .3 in the case of passenger ships, there are no passengers on board.

14.2.1 Operational readiness

14.2.1.1 The following fire protection systems shall be kept in good order so as to ensure their required performance if a fire occurs:

- .1 structural fire protection, including fire-resisting divisions, and protection of openings and penetrations in these divisions;
- .2 fire detection and fire alarm systems; and
- .3 means of escape systems and appliances.

14.2.1.2 Fire-fighting systems and appliances shall be kept in good working order and readily available for immediate use. Portable extinguishers which have been discharged shall be immediately recharged or replaced with an equivalent unit.

14.2.2 Maintenance, testing and inspections

14.2.2.1 Maintenance, testing and inspections shall be carried out based on the guidelines developed by IMO and adopted by *Register* (see *Revised Guidelines on maintenance and inspection of fire protection systems and appliances (MSC.1/Circ.1432)*, as amended by *MSC.1/Circ.1516*) and in a manner having due regard to ensuring the reliability of fire-fighting systems and appliances.

14.2.2.2 The maintenance plan shall be kept on board the ship and shall be available for inspection whenever required by the *Register*.

14.2.2.3 The maintenance plan shall include at least the following fire protection systems and fire-fighting systems and appliances, where installed:

- .1 fire mains, fire pumps and hydrants, including hoses, nozzles and international shore connections;
- .2 fixed fire detection and fire alarm systems;
- .3 fixed fire-extinguishing systems and other fire-extinguishing appliances;
- .4 automatic sprinkler, fire detection and fire alarm systems;
- .5 ventilation systems, including fire and smoke dampers, fans and their controls;
- .6 emergency shutdown of fuel supply;
- .7 fire doors, including their controls;
- .8 general emergency alarm systems;
- .9 emergency escape breathing devices;
- .10 portable fire extinguishers, including spare charges; and
- .11 fire-fighter's outfits.

14.2.2.4 The maintenance programme may be computer-based.

14.3 ADDITIONAL REQUIREMENTS FOR PASSENGER SHIPS

14.3.1 In addition to the fire protection systems and appliances listed in 14.2.2.3, ships carrying more than 36 passengers shall develop a maintenance plan for low-location lighting and public address systems.

14.4 ADDITIONAL REQUIREMENTS FOR TANKERS

14.4.1 In addition to the fire protection systems and appliances listed in 14.2.2.3, tankers shall have a maintenance plan for:

- .1 inert gas systems;
- .2 deck foam systems;
- .3 fire safety arrangements in cargo pump-rooms; and
- .4 flammable gas detectors.

15 INSTRUCTIONS, ONBOARD TRAINING AND DRILLS

15.1 PURPOSE

15.1.1 The purpose of this Section is to mitigate the consequences of fire by means of proper instructions for training and drills of persons on board in correct procedures under emergency conditions. For this purpose, the crew shall have the necessary knowledge and skills to handle fire emergency cases, including passenger care.

15.2 GENERAL REQUIREMENTS

15.2.1 Instructions, duties and organization

15.2.1.1 Crew members shall receive instruction on fire safety on board the ship.

15.2.1.2 Crew members shall receive instructions on their assigned duties.

15.2.1.3 Parties responsible for fire extinguishing shall be organized. These parties shall have the capability to complete their duties at all times while the ship is in service.

15.2.2 On-board training and drills

15.2.2.1 Crew members shall be trained to be familiar with the arrangements of the ship as well as the location and operation of any fire-fighting systems and appliances that they may be called upon to use.

15.2.2.2 Training in the use of the emergency escape breathing devices shall be considered as part of on-board training.

15.2.2.3 Performance of crew members assigned fire-fighting duties shall be periodically evaluated by conducting on-board training and drills to identify areas in need of improvement, to ensure competency in fire-fighting skills is maintained, and to ensure the operational readiness of the fire-fighting organization.

15.2.2.4 On-board training in the use of the ship's fire-extinguishing systems and appliances shall be planned and conducted.

15.2.2.5 Fire drills shall be conducted and recorded.

15.2.2.6 An onboard means of recharging breathing apparatus cylinders used during drills shall be provided or a suitable number of spare cylinders shall be carried on board to replace those used. See *IACS UI SC275*. See also *MSC.1/Circ.1555*.

15.2.3 Training manuals

15.2.3.1 A training manual shall be provided in each crew mess room and recreation room or in each crew cabin.

15.2.3.2 The training manual shall be written in the working language of the ship.

15.2.3.3 The training manual, which may comprise several volumes, shall contain the instructions and information required in 15.2.3.4 in easily understood terms and illustrated wherever possible. Any part of such information may be provided in the form of audio-visual aids in lieu of the manual.

15.2.3.4 The training manual shall explain the following in detail:

- .1 general fire safety practice and precautions related to the dangers of smoking, electrical hazards, flammable liquids and similar common shipboard hazards;
- .2 general instructions on fire-fighting activities and fire-fighting procedures, including procedures for notification of a fire and use of manually operated call points;
- .3 meanings of the ship's alarms;
- .4 operation and use of fire-fighting systems and appliances;
- .5 operation and use of fire doors;
- .6 operation and use of fire and smoke dampers; and
- .7 escape systems and appliances.

15.2.4 Fire control plans

15.2.4.1 General arrangement plans shall be permanently exhibited for the guidance of the ship's officers, showing clearly for each deck the control stations, the various fire sections enclosed by "A" class divisions, the sections enclosed by "B" class divisions together with particulars of the fire detection and fire alarm systems, the sprinkler installation, the fire-extinguishing appliances, means of access to different compartments, decks, etc., and the ventilating system, including particulars of the fan control positions, the position of dampers and identification numbers of the ventilating fans serving each section. Alternatively, at the discretion of the *Register*, the aforementioned details may be set out in a booklet, a copy of which shall be supplied to each officer, and one copy shall at all times be available on board in an accessible position. Plans and booklets shall be kept up to date; any alterations thereto shall be recorded as soon as practicable. Description in such plans and booklets shall be in the language or languages required by the Administration. If the language is neither English nor French, a translation into one of those languages shall be included.

15.2.4.2 In all ships, *except cargo ships of less than 500 gross tonnage irrespective of navigation area and except passenger ships of less than 500 gross tonnage intended for navigation area 6,7 or 8*, a duplicate set of fire control plans or a booklet containing such plans shall be permanently stored in a prominently marked weathertight enclosure outside the deckhouse for the assistance of shore-side fire-fighting personnel, see *Guidance concerning the location of fire control plans for assistance of shoreside fire-fighting personnel (MSC/Circ.451)*.

The position shall be marked with a sign as shown in Figure 15.2.4.2-1, be easy accessible and well illuminated.

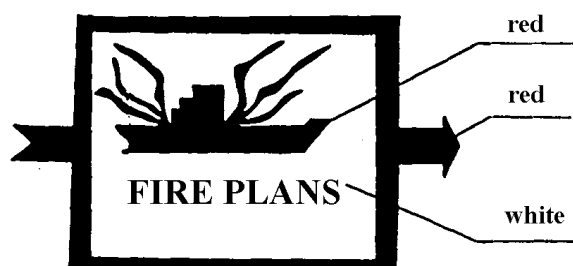

Figure 15.2.4.2-1

In tankers, combination carriers, chemical tankers and liquefied gas carriers this position shall be neither on the superstructure wall facing cargo area nor on the side walls within the distance 3 m from it.

If this position is not in a close vicinity of place of boarding the ship (near accommodation ladder) the signs as shown in Figure 15.2.4.2-2 shall be exhibited showing the way to such position.

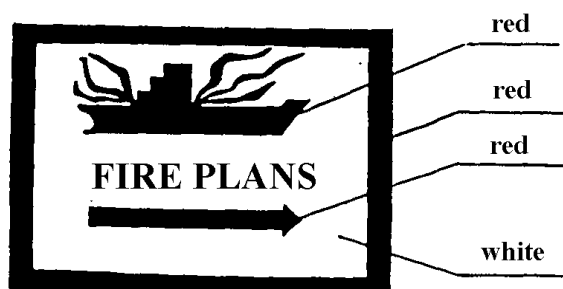

Figure 15.2.4.2-2

The signs shall have dimensions of not less than 400 mm x 300 mm.

15.2.4.3 Graphical symbols for fire control plans shall be colour painted and shall comply with IMO Res. A.952(23), as amended (see ISO 17631:2002).

Ships constructed before 1 January 2004 may continue to use the IMO Res. A.654(16), see MSC/Circ.1050.

See Escape route signs and equipment location markings (IMO Res. A.1116(30)).

15.2.4.4 Plans and booklets specified in 15.2.4.1 and 15.2.4.2 shall be kept up to date, any alterations being recorded thereon as soon as practicable.

15.2.4.5 The originator of plans and booklets specified in 15.2.4.1 and 15.2.4.2 shall ensure that the IMO ship identification number is marked on them prior to submission for approval (see MSC/Circ.1142).

15.3 ADDITIONAL REQUIREMENTS FOR PASSENGER SHIPS

15.3.1 Fire drills

In addition to the requirement of 15.2.2.3, fire drills shall be conducted, having due regard to notification of

passengers and movement of passengers to assembly stations and embarkation decks.

15.3.2 Fire control plans

In ships carrying more than 36 passengers, plans and booklets required by this Section shall provide information regarding fire protection, fire detection and fire extinction based on the guidelines developed by the IMO, see *Guidelines on the information to be provided with fire control plans and booklets required by SOLAS regulations II-2/ 20 and 41-2 (resolution A.756(18))*.

16 OPERATIONS

16.1 GENERAL REQUIREMENTS

16.1.1 The purpose of this Section is to provide information and instructions for proper ship and cargo handling operations in relation to fire safety. For this purpose, the following functional requirements shall be met:

- .1 fire safety operational booklets shall be provided on board; and
- .2 flammable vapour releases from cargo tank venting shall be controlled.

16.2 FIRE SAFETY OPERATIONAL BOOKLETS

16.2.1 The required fire safety operational booklet shall contain the necessary information and instructions for the safe operation of the ship and cargo handling operations in relation to fire safety. The booklet shall include information concerning the crew's responsibilities for the general fire safety of the ship while loading and discharging cargo and while under way. Necessary fire safety precautions for handling general cargoes shall be explained. For ships carrying dangerous goods and flammable bulk cargoes, the fire safety operational booklet shall also provide reference to the pertinent fire-fighting and emergency cargo handling instructions contained in the International Maritime Solid Bulk Cargoes (IMSBC) Code, the International Bulk Chemical Code, the International Gas Carrier Code and the International Maritime Dangerous Goods Code, as appropriate.

16.2.2 The fire safety operational booklet shall be provided in each crew mess room and recreation room or in each crew cabin.

16.2.3 The fire safety operational booklet shall be written in the working language of the ship.

16.2.4 The fire safety operational booklet may be combined with the training manuals required in 15.2.3.

16.2.5 When a hot work is planned on board the principles for hot work on board all types of ships shall be included in the fire safety operational booklet and followed (see *MSC/Circ.1084*).

16.3 ADDITIONAL REQUIREMENTS FOR TANKERS

16.3.1 General

The fire safety operational booklet referred to in 16.2 shall include provisions for preventing fire spread to the cargo area due to ignition of flammable vapours and include procedures of cargo tank gas-purging and/or gas-freeing, taking into account the provisions in 16.3.2.

16.3.2 Procedures for cargo tank purging and/or gas-freeing

16.3.2.1 When the ship is provided with an inert gas system, the cargo tanks shall first be purged in accordance with the provisions of 4.5.6 until the concentration of hydrocarbon vapours in the cargo tanks has been reduced to less than 2% by volume. Thereafter, gas-freeing may take place at the cargo tank deck level.

16.3.2.2 When the ship is not provided with an inert gas system, the operation shall be such that the flammable vapour is discharged initially through:

- .1 the vent outlets as specified in 4.5.3.4;
- .2 outlets at least 2 m above the cargo tank deck level with a vertical efflux velocity of at least 30 m/s maintained during the gas-freeing operation; or
- .3 outlets at least 2 m above the cargo tank deck level with a vertical efflux velocity of at least 20 m/s and which are protected by suitable devices to prevent the passage of flame.

16.3.2.3 The above outlets shall be located not less than 10 m, measured horizontally, from the nearest air intakes and openings to enclosed spaces containing a source of ignition and from deck machinery, which may include anchor windlass and chain locker openings, and equipment which may constitute an ignition hazard. See also *MSC.1/Circ.1459*.

16.3.2.4 When the flammable vapour concentration at the outlet has been reduced to 30% of the lower flammable limit, gas-freeing may be continued at cargo tank deck level.

16.3.3 Operation of inert gas system

16.3.3.1 The inert gas system for tankers required in accordance with 4.5.5.1 shall be so operated as to render and maintain the atmosphere of the cargo tanks non-flammable, except when such tanks are required to be gas-free.

16.3.3.2 Notwithstanding the above, for chemical tankers, the application of inert gas, may take place after the cargo tank has been loaded, but before commencement of unloading and shall continue to be applied until that cargo tank has been purged of all flammable vapours before gas-freeing. Only nitrogen is acceptable as inert gas under this provision.

16.3.3.3 Notwithstanding 1.1.10.1.2, the provisions of this paragraph shall only apply to tankers constructed on or after 1 January 2016. If the oxygen content of the inert gas exceeds 5% by volume, immediate action shall be taken to improve the gas quality. Unless the quality of the gas improves, all operations in those cargo tanks to which inert gas is being supplied shall be suspended so as to avoid air being drawn into the cargo tanks; the gas regulating valve, if fitted, shall be closed and the off-specification gas shall be vented to atmosphere.

16.3.3.4 In the event that the inert gas system is unable to meet the requirement in 16.3.3.1 and it has been assessed that it is impractical to effect a repair, then cargo discharge and cleaning of those cargo tanks requiring inerting shall only be resumed when suitable emergency procedures have been followed, taking into account guidelines developed by the IMO and adopted by *Register*, see *Clarification of inert gas system requirements under the Convention (MSC/Circ.485)* and *Re-*

vised Guidelines for inert gas systems (MSC/Circ.353), as amended by MSC/Circ.387.

16.3.3.5 For ships carrying products requiring oxygen-dependent inhibitors see *MSC.1/Circ.1501*.

17 ALTERNATIVE DESIGN AND ARRANGEMENTS

17.1 PURPOSE

17.1.1 The purpose of this Section is to provide a methodology for alternative design and arrangements for fire safety.

17.2 GENERAL

17.2.1 Fire safety design and arrangements may deviate from the prescriptive requirements set out in Sections 4 to 16 and 18 to 25, provided that the design and arrangements meet the fire safety objectives and the functional requirements.

17.2.2 When fire safety design or arrangements deviate from the prescriptive requirements of this Rules for the classification of ships, engineering analysis, evaluation and approval of the alternative design and arrangements shall be carried out in accordance with this Section.

17.3 ENGINEERING ANALYSIS

17.3.1 The engineering analysis shall be prepared and submitted to the *Register*, based on the guidelines developed by IMO and adopted by the *Register* (see *MSC/Circ.1002*, *MSC.1/Circ.1002/Corr.1*, *MSC.1/Circ.1002/Corr.2*, *MSC.1/Circ.1002/Corr.3* and *MSC.1/Circ.1552*), and shall include, as a minimum, the following elements:

- .1 determination of the ship type and space(s) concerned;
- .2 identification of prescriptive requirement(s) with which the ship or the space(s) will not comply;
- .3 identification of the fire and explosion hazards of the ship or the space(s) concerned, including:
 - .3.1 identification of the possible ignition sources;
 - .3.2 identification of the fire growth potential of each space concerned;
 - .3.3 identification of the smoke and toxic effluent generation potential for each space concerned;
 - .3.4 identification of the potential for the spread of fire, smoke or of toxic effluents from the space (s) concerned to other spaces;
- .4 determination of the required fire safety performance criteria for the ships or the space(s) concerned addressed by the prescriptive requirement(s), in particular:
 - .4.1 performance criteria shall be based on the fire safety objectives and on the functional requirements of this Rules for the classification of ships;
 - .4.2 performance criteria shall provide a degree of safety not less than that achieved by using the prescriptive requirements; and

- .4.3 performance criteria shall be quantifiable and measurable;
- .5 detailed description of the alternative design and arrangements, including a list of the assumptions used in the design and any proposed operational restrictions or conditions; and
- .6 technical justification demonstrating that the alternative design and arrangements meet the required fire safety performance criteria.

17.4 EVALUATION OF THE ALTERNATIVE DESIGN AND ARRANGEMENTS

17.4.1 The engineering analysis required in 17.3 shall be evaluated and approved by the *Register*, taking into account the guidelines developed by IMO and adopted by the *Register* (see *Guidelines on alternative design and arrangements for fire safety (MSC/Circ.1002, MSC.1/Circ.1002/Corr.1, MSC.1/Circ.1002/Corr.2, MSC.1/Circ.1002/Corr.3 and MSC.1/Circ.1552)*).

17.4.2 A copy of the documentation, as approved by the *Register*, indicating that the alternative design and arrangements comply with this Section shall be carried on board the ship.

17.5 EXCHANGE OF INFORMATION

17.5.1 The Administration shall communicate to the IMO pertinent information concerning alternative design and arrangements approved by them for circulation to all Contracting Governments.

17.6 RE-EVALUATION DUE TO CHANGE OF CONDITIONS

17.6.1 If the assumptions, and operational restrictions that were stipulated in the alternative design and arrangements are changed, the engineering analysis shall be carried out under the changed condition and shall be approved by the *Register*.

18 HELICOPTER FACILITIES

18.1 GENERAL REQUIREMENTS

18.1.1 The purpose of this Section is to provide additional measures in order to address the fire safety objectives of this Rules for the classification of ships for ships fitted with special facilities for helicopters. For this purpose, the following functional requirements shall be met:

- .1 helideck structure shall be adequate to protect the ship from the fire hazards associated with helicopter operations;
- .2 fire-fighting appliances shall be provided to adequately protect the ship from the fire hazards associated with helicopter operations;
- .3 refuelling and hangar facilities and operations shall provide the necessary measures to protect the ship from the fire hazards associated with helicopter operations; and
- .4 operation manuals and training shall be provided.

18.2 APPLICATION

18.2.1 In addition to complying with the requirements of other Sections, as appropriate, ships equipped with helidecks shall comply with the requirements of this Section.

18.2.2 Where helicopters land or conduct winching operations on an occasional or emergency basis on ships without helidecks, fire-fighting equipment fitted in accordance with the requirements of this Part of the Rules for the classification of ships may be used. This equipment shall be made readily available in close proximity to the landing or winching areas during helicopter operations.

18.2.3 Notwithstanding the requirements of 18.2.2, ships constructed on or after 1 January 2020, having a helicopter landing area, shall be provided with foam fire-fighting appliances which comply with the relevant provisions of 24.17.

18.2.4 Notwithstanding the requirements of 18.2.2 or 18.2.3, ro-ro passenger ships without helidecks shall comply with SOLAS, Regulation III/28.

18.2.5 Helicopter facility foam fire-fighting appliances shall be in compliance with *Guidelines for approval of helicopter foam fire-fighting appliances (MSC.1/Circ.1431)*.

18.3 STRUCTURE

18.3.1 Construction of steel or other equivalent material

In general, the construction of the helidecks shall be of steel or other equivalent materials. If the helideck forms the deckhead of a deckhouse or superstructure, it shall be insulated to "A-60" class standard.

18.3.2 Construction of aluminium or other low melting point metals

If the *Register* permits aluminium or other low melting point metal construction that is not made equivalent to steel, the following provisions shall be satisfied:

- .1 if the platform is cantilevered over the side of the ship, after each fire on the ship or on the platform, the platform shall undergo a structural analysis to determine its suitability for further use; and
- .2 if the platform is located above the ship's deckhouse or similar structure, the following conditions shall be satisfied:
 - .2.1 the deckhouse top and bulkheads under the platform shall have no openings;
 - .2.2 windows under the platform shall be provided with steel shutters; and
 - .2.3 after each fire on the platform or in close proximity, the platform shall undergo a structural analysis to determine its suitability for further use.

18.4 MEANS OF ESCAPE

18.4.1 A helideck shall be provided with both a main and an emergency means of escape and access for firefighting and rescue personnel. These shall be located as far apart from each other as is practicable and preferably on opposite sides of the helideck.

18.5 FIRE-FIGHTING APPLIANCES

18.5.1 In close proximity to the helideck, the following fire-fighting appliances shall be provided and stored near the means of access to that helideck:

- .1 at least two dry powder extinguishers having a total capacity of not less than 45 kg, see *MSC.1/Circ.1275* and *MSC.1/Circ.1275/Corr.1* ;
- .2 carbon dioxide extinguishers of a total capacity of not less than 18 kg or equivalent, see *MSC.1/Circ.1275* and *MSC.1/Circ.1275/Corr.1* ;
- .3 a suitable foam application system consisting of monitors or foam-making branch pipes capable of delivering foam to all parts of the helideck in all weather conditions in which helicopters can operate. The system shall be capable of delivering a discharge rate as required in table 18.1 for at least five minutes;
- .4 the principal agent shall be suitable for use with salt water and conform to performance standards not inferior to those acceptable to the *Register*; refer to the *International Civil Aviation Organization Airport Services Manual, part 1, Rescue and Fire Fighting, Chapter 8, Extinguishing Agent Characteristics, paragraph 8.1.5, Foam Specifications table 8-1, level 'B'*.
- .5 at least two nozzles of an approved dual-purpose type (jet/spray) and hoses sufficient to reach any part of the helideck;

- .6 in lieu of the requirements of 18.5.1.3 through 18.5.1.5, on ships constructed on or after 1 January 2020 having a helideck, foam firefighting appliances which comply with the provisions of the Fire Safety Systems Code.
- .7 in addition to the requirements of 10.10, two sets of fire-fighter's outfits; and
- .8 at least the following equipment shall be stored in a manner that provides for immediate use and protection from the elements: adjustable wrench; blanket, fire-resistant; cutters, bolt, 60 cm; hook, grab or salving; hacksaw, heavy duty complete with 6 spareblades; ladder; lift line 5 mm diameter and 15 m in length; pliers, side-cutting; set of assorted screwdrivers; and harness knife complete with sheath.

Table 18.1 Foam discharge rates

| Category | Helicopter overall length | Discharge rate foam solution (lit./min.) |
|----------|-----------------------------------|--|
| H1 | Less than 15 m | 250 |
| H2 | 15 m and over, but less than 24 m | 500 |
| H3 | 24 m and over, but less than 35 m | 800 |

18.6 DRAINAGE FACILITIES

18.6.1 Drainage facilities in way of helidecks shall be constructed of steel and shall lead directly overboard independent of any other system and shall be designed so that drainage does not fall onto any part of the ship.

18.7 HELICOPTER REFUELLING AND HANGAR FACILITIES

18.7.1 Where the ship has helicopter refuelling and hangar facilities, the following requirements shall be complied with:

- .1 a designated area shall be provided for the storage of fuel tanks which shall be:
 - .1.1 as remote as is practicable from accommodation spaces, escape routes and embarkation stations; and
 - .1.2 isolated from areas containing a source of vapour ignition;
- .2 the fuel storage area shall be provided with arrangements whereby fuel spillage may be collected and drained to a safe location;
- .3 tanks and associated equipment shall be protected against physical damage and from a fire in an adjacent space or area;
- .4 where portable fuel storage tanks are used, special attention shall be given to:
 - .4.1 design of the tank for its intended purpose;
 - .4.2 mounting and securing arrangements;
 - .4.3 electric bonding; and
 - .4.4 inspection procedures;

- .5 storage tank fuel pumps shall be provided with means which permit shutdown from a safe remote location in the event of a fire. Where a gravity fuelling system is installed, equivalent closing arrangements shall be provided to isolate the fuel source;
- .6 the fuel pumping unit shall be connected to one tank at a time. The piping between the tank and the pumping unit shall be of steel or equivalent material, as short as possible, and protected against damage;
- .7 electrical fuel pumping units and associated control equipment shall be of a type suitable for the location and potential hazards;
- .8 fuel pumping units shall incorporate a device which will prevent over-pressurization of the delivery or filling hose;
- .9 equipment used in refuelling operations shall be electrically bonded;
- .10 "NO SMOKING" signs shall be displayed at appropriate locations;
- .11 hangar, refuelling and maintenance facilities shall be treated as category A machinery spaces with regard to structural fire protection, fixed fire-extinguishing and detection system requirements;
- .12 enclosed hangar facilities or enclosed spaces containing refuelling installations shall be provided with mechanical ventilation, as required by 20.3 for closed ro-ro spaces of cargo ships. Ventilation fans shall be of non-sparking type; and
- .13 electric equipment and wiring in enclosed hangars or enclosed spaces containing refuelling installations shall comply with 20.3.2, 20.3.3 and 20.3.4.

18.8 OPERATIONS MANUAL AND FIRE-FIGHTING ARRANGEMENTS

18.8.1 Each helicopter facility shall have an operations manual, including a description and a checklist of safety precautions, procedures and equipment requirements. This manual may be part of the ship's emergency response procedures.

18.8.2 The procedures and precautions to be followed during refuelling operations shall be in accordance with recognized safe practices and contained in the operations manual.

18.8.3 Fire-fighting personnel, consisting of at least two persons trained for rescue and fire-fighting duties, and fire-fighting equipment shall be immediately available at all times when helicopter operations are expected.

18.8.4 Fire-fighting personnel shall be present during refuelling operations. However, the fire-fighting personnel shall not be involved with refuelling activities.

18.8.5 On-board refresher training shall be carried out and additional supplies of fire-fighting media shall be provided for training and testing of the equipment.

19 CARRIAGE OF DANGEROUS GOODS

19.1 PURPOSE

19.1.1 The purpose of this Section is to provide additional safety measures in order to address the fire safety objectives of this Rules for the classification of ships for ships carrying dangerous goods. For this purpose, the following functional requirements shall be met:

- .1 fire protection systems shall be provided to protect the ship from the added fire hazards associated with carriage of dangerous goods;
- .2 dangerous goods shall be adequately separated from ignition sources; and
- .3 appropriate personnel protective equipment shall be provided for the hazards associated with the carriage of dangerous goods.

19.2 GENERAL REQUIREMENTS

19.2.1 In addition to complying with the requirements of Sections 3 to 16 and Sections 18 and 20 (Refer to *part 7 of the IMDG Code*), as appropriate, ship types and cargo spaces, referred to in 19.2.2, intended for the carriage of dangerous goods shall comply with the requirements of this Section, as appropriate, except when carrying dangerous goods in limited quantities (refer to *Chapter 3.4 of the IMDG Code*) and excepted quantities (refer to *Chapter 3.5 of the IMDG Code*) unless such requirements have already been met by compliance with the requirements elsewhere in this Rules for the classification of ships. The types of ships and modes of carriage of dangerous goods are referred to in 19.2.2 and in table 19.1.

Cargo ships of less than 500 gross tonnage, but not less than 300, shall comply with this Section, but *Register* may reduce the requirements and such reduced requirements shall be recorded in the document of compliance referred to in 19.4.

Unless expressly provided otherwise the application of the requirements of this Section to cargo ships of less than 300 gross tonnage is subject to special consideration by the *Register* in each particular case.

19.2.2 The following ship types and cargo spaces shall govern the application of tables 19.1 and 19.2:

- .1 ships and cargo spaces not specifically designed for the carriage of freight containers, but intended for the carriage of dangerous goods in packaged form, including goods in freight containers and portable tanks;
- .2 purpose-built containerships and cargo spaces intended for the carriage of dangerous goods in freight containers and portable tanks, see *IACS UI SC84 Rev.2*;
- .3 ro-ro ships and ro-ro spaces intended for the carriage of dangerous goods, see *IACS UI SC85, Rev.2*;

- .4 ships and cargo spaces intended for the carriage of solid dangerous goods in bulk; and
- .5 ships and cargo spaces intended for carriage of dangerous goods other than liquids and gases in bulk in shipborne barges.

19.2.3 A ship, except a cargo ship of less than 300 gross tonnage, intended for the carriage of dangerous goods in any cargo spaces, "on deck" or "under deck", shall be provided with a fixed carbon dioxide fire-extinguishing system or with a fire-extinguishing system which, in the opinion of the *Register*, gives equivalent protection for the cargoes being carried (see Annex 4, Table 2-1).

19.2.4 Notwithstanding the requirements specified in 19.2.3, in ships intended solely for the carriage of non-combustible and/or low fire risk dangerous goods the installation of a fire-extinguishing system in cargo spaces may be dispensed with on application to the *Register* (see Annex 4, Table 1-1).

For self-heating solid bulk cargoes see *MSC.1/Circ.1456*, item 5.

19.2.5 Ships intended for the carriage of dangerous goods shall be provided with relevant instructions (IMDG Code, IMSBC Code, MFAG and EmS) which describe all essential operational procedures for the carriage and accidents for the cargoes being carried.

19.2.6 For solid dangerous goods in bulk and packaged dangerous goods in classes 6.2 and 7 there are no special requirements to ship's construction and equipment regarding fire protection, fire detection and fire extinction (for the specific operational requirements see IMDG Code, IMSBC Code and/or INF Code, as appropriate).

19.3 SPECIAL REQUIREMENTS

Unless otherwise specified, the following requirements shall govern the application of tables 19.1, 19.2 and 19.3 to both "on-deck" and "under-deck" stowage of dangerous goods where the numbers of the following items are indicated in the first column of the tables.

See *IACS UI SC87 Rev.2*.

19.3.1 Water supplies

See *IACS UI SC109 Rev.1* and *IACS UI SC270 Rev.1*. See also *MSC.1/Circ.1550*.

19.3.1.1 Arrangements shall be made to ensure immediate availability of a supply of water from the fire main at the required pressure either by permanent pressurization or by suitably placed remote arrangements for the fire pumps.

19.3.1.2 The quantity of water delivered shall be capable of supplying four nozzles of a size and at pressures as specified in 10.2, capable of being trained on any part of the cargo space when empty. This amount of water may be applied by equivalent means to the satisfaction of the *Register*. See *IACS UI SC168 Rev.1*.

On ships of less than 300 gross tonnage, the quantity of water delivered shall be capable of supplying two nozzles of a size and at pressures as specified in 10.2, capable of being trained on any part of the cargo space when empty. In

the case of discrepancy between the specific regulations of the Flag State Administration (if available) and this requirement, the former shall apply.

19.3.1.3 Means shall be provided for effectively cooling the designated under-deck cargo space by at least 5 L/min per square metre of the horizontal area of cargo spaces, either by a fixed arrangement of spraying nozzles or by flooding the cargo space with water. Hoses may be used for this purpose in small cargo spaces and in small areas of larger cargo spaces at the discretion of the *Register*. However, the drainage and pumping arrangements shall be such as to prevent the build-up of free surfaces. The drainage system shall be sized to remove no less than 125% of the combined capacity of both the water spraying system pumps and the required number of fire hose nozzles. The drainage system valves shall be operable from outside the protected space at a position in the vicinity of the extinguishing system controls. Bilge wells shall be of sufficient holding capacity and shall be arranged at the side shell of the ship at a distance from each other of not more than 40 m in each watertight compartment. If this is not possible, the adverse effect upon stability of the added weight and free surface of water shall be taken into account to the extent deemed necessary by the *Register* in its approval of the stability information, see *Rules for the classification of ships, Part 5.- Sub-division, Section 2 and 3*; see also *Recommendation on fixed fire-extinguishing systems for special category spaces (resolution A.123(V))* and *MSC.1/Circ.1234*.

19.3.1.4 Provision to flood a designated under-deck cargo space with suitable specified media may be substituted for the requirements in 19.3.1.3.

19.3.1.5 The total required capacity of the water supply shall satisfy 19.3.1.2 and 19.3.1.3, if applicable, simultaneously calculated for the largest designated cargo space. The capacity requirements of 19.3.1.2 shall be met by the total capacity of the main fire pump(s), not including the capacity of the emergency fire pump, if fitted. If a drencher system is used to satisfy 19.3.1.3, the drencher pump shall also be taken into account in this total capacity calculation.

19.3.2 Sources of ignition

Electrical equipment and wiring shall not be fitted in enclosed cargo spaces or vehicle spaces unless it is essential for operational purposes in the opinion of the *Register*. However, if electrical equipment is fitted in such spaces, it shall be of a certified safe type (see *recommendations of the International Electrotechnical Commission, in particular publication IEC 60092, Electrical installations in ships*) for use in the dangerous environments to which it may be exposed unless it is possible to completely isolate the electrical system (e.g. by removal of links in the system, other than fuses). See *MSC.1/Circ.1555*.

Electrical appliances which are not required in conjunction with the transport of dangerous goods or which are not essential either for the safety of the ship or crew need not have a type of protection corresponding to the goods to be transported if they can be isolated from the electrical supply completely and protected against unauthorized reconnection.

Disconnection shall be made outside the hazardous areas and shall be effected by removal of links in the system, other than fuses, or with lockable switches.

Portable electrical equipment which is necessary for ship operation or which is required by the Rules for the classification of ships shall be of certified safe type.

Cable penetrations of the decks and bulkheads shall be sealed against the passage of gas or vapour. Through runs of cables and cables within the cargo spaces shall be protected against damage from impact (see the *Rules for the classification of ships, Part 12 - Electrical Equipment, 2.9 and 16.8*).

Any other equipment which may constitute a source of ignition of flammable vapour shall not be permitted.

See *IACS UI SC 79, Rev.5*.

19.3.3 Detection system

Ro-ro spaces shall be fitted with a fixed fire detection and fire alarm system complying with the requirements of the Section 24. All other types of cargo spaces shall be fitted with either a fixed fire detection and fire alarm system or a sample extraction smoke detection system complying with the requirements of the Section 24. If a sample extraction smoke detection system is fitted, particular attention shall be given to 24.10.2.1.3 order to prevent the leakage of toxic fumes into occupied areas.

19.3.4 Ventilation arrangement

See *IACS UI SC89 Rev.4* and *IACS UI SC110 Rev.1*. See also *MSC.1/Circ.1434*.

19.3.4.1 Adequate power ventilation shall be provided in enclosed cargo spaces. The arrangement shall be such as to provide for at least six air changes per hour in the cargo space, based on an empty cargo space, and for removal of vapours from the upper or lower parts of the cargo space, as appropriate.

The fan(s) shall be permanently fitted or of a portable type adapted for being permanently fitted prior to loading and during voyage.

The height of ventilation inlets and outlets shall satisfy the International Convention on Load Lines in force, for openings fitted with closing appliances. The means of closure for fire protection shall be fitted in accordance with 5.2.1.2.

19.3.4.2 The fans shall be such as to avoid the possibility of ignition of flammable gas/air mixtures. Suitable wire mesh guards shall be fitted over inlet and outlet ventilation openings. See *IACS UI SC52 Rev.1*.

19.3.4.3 Natural ventilation shall be provided in enclosed cargo spaces intended for the carriage of solid dangerous goods in bulk, where there is no provision for mechanical ventilation.

19.3.5 Bilge pumping

See *IACS UI SC90 Rev.1* and *IACS UI SC111 Rev.1*.

19.3.5.1 Where it is intended to carry flammable or toxic liquids in enclosed cargo spaces, the bilge pumping system shall be designed to protect against inadvertent pumping of such liquids through machinery space piping or pumps. Where large quantities of such liquids are carried, consideration shall be given to the provision of additional means of draining those

cargo spaces. These means shall be to the satisfaction of the *Register*.

If bilge ejectors are used driving water may be taken from a pump in the machinery space provided a non-return valve shall be fitted in the supply line.

19.3.5.2 If the bilge drainage system is additional to the system served by pumps in the machinery space, the capacity of the system shall be not less than 10 m³/h per cargo space served. If the additional system is common, the capacity need not exceed 25 m³/h. The additional bilge system need not be arranged with redundancy.

If a single bilge pumping system completely independent of the machinery space is provided, the system shall comply with the requirements to redundancy and capacity based on the size of the space or spaces which it serves, as specified in the *Rules for the classification of ships, Part 8 – Piping, Section 2*.

19.3.5.3 Whenever flammable or toxic liquids are carried, the bilge line into the machinery space shall be isolated either by fitting a blank flange or by a closed lockable valve.

Warning plates against inadvertent opening shall be exhibited in the close vicinity.

19.3.5.4 Enclosed spaces outside machinery spaces containing bilge pumps serving cargo spaces intended for carriage of flammable or toxic liquids shall be fitted with separate mechanical ventilation giving at least six air changes per hour. If the space has access from another enclosed space, the door shall be self-closing. See *IACS UI SC288*.

19.3.5.5 If bilge drainage of cargo spaces is arranged by gravity drainage, the drainage shall be either led directly overboard or to a closed drain tank located outside the machinery spaces. The tank shall have a minimum volume sufficient to accumulate 1/3 of the drainage capacity per hour of the largest cargo space. The tank shall be provided with a vent pipe to a safe location on the open deck. Drainage from a cargo space into bilge wells in a lower space is only permitted if that space satisfies the same requirements as the cargo space above.

19.3.6 Personnel protection

19.3.6.1 Four sets of full protective clothing, resistant to chemical attack, shall be provided in addition to the fire-fighter's outfits required by 10.10. The protective clothing shall cover all skin, so that no part of the body is unprotected and shall be selected taking into account the hazards associated with the chemicals being transported and the standards adopted by the *Register* according to the class and physical state. For solid bulk cargoes, the protective clothing should satisfy the equipment provisions specified in the respective schedules of the *IMSBC Code for the individual substances*. For packaged goods, the protective clothing should satisfy the equipment provisions specified in *emergency procedures (EmS) of the Supplement to the IMDG Code for the individual substances*.

See *IACS UI SC91 Rev.1 Corr.1*.

In cargo ships of less than 300 gross tonnage and in passenger ships not intended for international voyages of less than 500 gross tonnage, but not less than 300, not more than two sets of protective clothing are required.

19.3.6.2 At least two self-contained breathing apparatuses additional to those required by 10.10 shall be provided. Two spare charges suitable for use with the breathing apparatus shall be provided for each required apparatus.

Passenger ships carrying not more than 36 passengers and cargo ships that are equipped with suitably located means for fully recharging the air cylinders free from contamination need carry only one spare charge for each required apparatus. See *IACS UI SC92 Rev.1*.

In cargo ships of less than 300 gross tonnage and in passenger ships not intended for international voyages of less than 500 gross tonnage but not less than 300, having open ro-ro space, only one breathing apparatus with one set of air bottles is required.

19.3.6.3 Where ship's hospital is required, it shall have a 40 litre/200 bar medical oxygen cylinder, assembled for direct use, equipped with one flow-meter unit for supplying oxygen for two persons simultaneously, and a complete portable set, ready for use, with a 2 litre/200 bar medical oxygen cylinder and a spare cylinder (also 2 litre/200 bar). The 40 litre/200 bar cylinders shall be stored in fixed supports connected directly to ships steel structure within the ship's hospital. The cylinders shall be stored within a steel cabinet with natural ventilation to free air. Signboard warning of possible ignition caused by static electricity from clothing or open flame when medical oxygen is used (released) shall be posted on the cabinet.

Alternative arrangements, which in the opinion of the *Register* are equivalent, may be accepted.

19.3.7 Portable fire extinguishers

Portable fire extinguishers with a total capacity of at least 12 kg of dry powder or equivalent shall be provided for the cargo spaces. These extinguishers shall be in addition to any portable fire extinguishers required elsewhere in this Rules for the classification of ships.

See *MSC.1/Circ.1275* and *MSC.1/Circ.1275/Corr.1*.

19.3.8 Insulation of machinery space boundaries

Bulkheads forming boundaries between cargo spaces and machinery spaces of category A shall be insulated to "A-60" class standard, unless the dangerous goods are stowed at least 3 m horizontally away from such bulkheads. Other boundaries between such spaces shall be insulated to "A-60" class standard. See *IACS UI SC103 Rev.1*.

No loading of dangerous goods shall be permitted in the closed or semi-closed cargo space located partly above the machinery space of category A if the deck above the machinery space is not insulated to "A-60" standard.

If the uninsulated deck above the machinery space of category A is a weather deck, no loading of the dangerous goods shall be permitted for the portion of the deck located above the machinery space.

19.3.9 Water-spray system

Each open ro-ro space having a deck above it and each space deemed to be a closed ro-ro space not capable of being sealed shall be fitted with an approved fixed pressure water-spraying system for manual operation which shall protect all parts of any deck and vehicle platform in the space, ex-

cept that the *Register* may permit the use of any other fixed fire-extinguishing system that has been shown by full-scale test to be no less effective.

However, the drainage and pumping arrangements shall be such as to prevent the build-up of free surfaces. The drainage system shall be sized to remove no less than 125% of the combined capacity of both the water-spraying system pumps and the required number of fire hose nozzles. The drainage system valves shall be operable from outside the protected space at a position in the vicinity of the extinguishing system controls. Bilge wells shall be of sufficient holding capacity and shall be arranged at the side shell of the ship at a distance from each other of not more than 40 m in each watertight compartment. If this is not possible, the adverse effect upon stability of the added weight and free surface of water shall be taken into account to the extent deemed necessary by the *Register* in its approval of the stability information, see the *Rules for the classification of ships, Part 5.- Subdivision, Section 2 and 3*; see also *Recommendation on fixed fire-extinguishing systems for special category spaces (resolution A.123(V)) and MSC.1/Circ.1234*.

19.3.10 Separation of ro-ro spaces

19.3.10.1 In ships having ro-ro spaces, a separation shall be provided between a closed ro-ro space and an adjacent open ro-ro space. The separation shall be such as to minimize the passage of dangerous vapours and liquids between such spaces. Alternatively, such separation need not be provided if the ro-ro space is considered to be a closed cargo space over its entire length and fully complies with the relevant special requirements of this Section.

19.3.10.2 In ships having ro-ro spaces, a separation shall be provided between a closed ro-ro space and the adjacent weather deck. The separation shall be such as to minimize the passage of dangerous vapours and liquids between such spaces. Alternatively, a separation need not be provided if the arrangements of the closed ro-ro spaces are in accordance with those required for the dangerous goods carried on adjacent weather decks.

19.4 DOCUMENT OF COMPLIANCE

19.4.1 The *Register* shall provide the ship with an appropriate document as evidence of compliance of construction and equipment with the requirements of this Section (see *MSC.1/Circ.1266*). Certification for dangerous goods, except solid dangerous goods in bulk, is not required for those cargoes specified as class 6.2 and 7 and dangerous goods in limited quantities and excepted quantities.

The cargoes covered by the IMSBC Code do not require certification, unless such cargoes are classified as dangerous goods, except class 6.2 and 7.

Such a document of compliance is required only when a ship carries or intends to carry dangerous goods and is (see *MSC/Circ.858*):

- .1 a passenger ship constructed on or after 1 September 1984; or
- .2 a cargo ship of 500 GT or over constructed on or after 1 September 1984; or
- .3 a cargo ship of less than 500 GT constructed on or after 1 February 1992.

See *IACS UI SC87 Rev.2* and *IACS UI SC196*.

See *Document of compliance with the special requirements for ships carrying dangerous goods under the provisions of regulation 19, as amended, and paragraph 7.17 of the 2000 HSC Code, as amended (MSC.1/Circ.1266)*.

19.5 ADDITIONAL REQUIREMENTS FOR PASSENGER SHIPS, INCLUDING RO-RO PASSENGER SHIPS

19.5.1 Dangerous goods in packaged form may be carried in passenger ships provided the requirements specified in 19.2 and 19.3 are complied with and observing the restrictions given in 19.5.2 to 19.5.10.

19.5.2 Except for class 1 – Explosives, dangerous goods may be carried in passenger ships provided the restrictions with regard to the stowage and location of such goods and number of passengers onboard, as specified in IMDG Code are observed.

19.5.3 Goods of class 1 which may be carried in passenger ships are identified in the Dangerous Goods List of the IMDG Code.

19.5.4 Notwithstanding the restrictions in 19.5.3 additional quantities or types of explosives may be carried in passenger ships in which special safety measures approved by the *Register* are taken.

19.5.5 Articles in compatibility group N, shall only be allowed in passenger ships if the total net explosive mass does not exceed quantity specified in IMDG Code per ship and no other explosives, apart from division 1.4 compatibility group S, are carried.

19.5.6 Stowage and handling of goods of class 1 shall comply with stowage categories as specified in IMDG Code and observing the stowage restrictions with regard to the compatibility group of the IMDG Code.

19.5.7 Passengers and other unauthorized persons shall be excluded from vehicle decks on which dangerous goods have been loaded. All doors leading directly to these decks shall be securely closed during the voyage and notices or signs prohibiting entrance to such decks shall be conspicuously displayed.

During the voyage access to such decks by passengers and other unauthorized persons shall only be permitted when such persons are accompanied by an authorized crew member.

The transport of dangerous goods shall be prohibited on any vehicle deck on which the foregoing provisions cannot be met.

19.5.8 Closing arrangements for the openings between ro-ro spaces and machinery and accommodation spaces shall be such as to avoid the possibility of dangerous vapours and liquids entering such spaces. Such openings shall normally be kept securely closed when dangerous cargo is on board, except to permit access by authorized persons or for emergency use.

19.5.9 Ro-ro ships may carry dangerous goods in cargo transport units or stowed in the conventional way on vehicle decks, in cargo holds or on weather decks. The provisions for

such stowage shall be in compliance with the relevant provisions laid down in the IMDG Code.

19.5.10 Stowage requirements and/or restrictions for individual substances may be specified in the Dangerous Goods List of the IMDG Code or by the Administration.

Table 19.1
Application of the special requirements to different modes of carriage of dangerous goods in ships and cargo spaces*

| Ships and cargo spaces: 19.2.2 Requirements in Section 19 | Weather decks .1 to .5 inclusive | .1 | .2 | .3 | | .4 | .5 |
|--|----------------------------------|---------------------------|------------------------|---------------------------|------|---|------------------|
| | | Not specifically designed | Container cargo spaces | Ro-ro spaces ⁵ | | Solid dangerous goods in bulk (only) | Shipborne barges |
| | | | | closed | open | | |
| .3.1.1 | X | X | X | X | X | For application of requirements of this Section to different classes of dangerous goods, see Table 19.2 | X |
| .3.1.2 | X | X | X | X | X | | – |
| .3.1.3 | – | X | X | X | X | | X |
| .3.1.4 | – | X | X | X | X | | X ⁴ |
| .3.2 | – | X | X | X | X | | X ⁴ |
| .3.3 | – | X | X | X | – | | X ⁴ |
| .3.4.1 | – | X | X ¹ | X | – | | X ⁴ |
| .3.4.2 | – | X | X ¹ | X | – | | X ⁴ |
| .3.5 | – | X | X | X | – | | – |
| .3.6.1 | X | X | X | X | X | | – |
| .3.6.2 | X | X | X | X | X | | – |
| .3.7 | X | X | – | – | X | | – |
| .3.8 | X | X | X ² | X | X | | – |
| .3.9 | – | – | – | X ³ | X | | – |
| .3.10.1 | – | – | – | X | – | | – |
| .3.10.2 | – | – | – | X | – | | – |

* Wherever X appears in Table 19.1 it means this requirement is applicable to all classes of dangerous goods as given in the appropriate line of Table 19.3, except as indicated by the notes.

Notes to Table 19.1

- For classes 4 and 5.1 solids not applicable to closed freight containers. For classes 2, 3, 6.1 and 8 when carried in closed freight containers, the ventilation rate may be reduced to not less than two air changes per hour. For classes 4 and 5.1 liquids when carried in closed freight containers, the ventilation rate may be reduced to not less than two air changes per hour. For the purpose of this requirement, a portable tank is a closed freight container. See *IACS UI SC288*.
- Applicable to decks only.
- Applies only to closed ro-ro spaces, not capable of being sealed.
- In the special case where the barges are capable of containing flammable vapours or alternatively if they are capable of discharging flammable vapours to a safe space outside the barge carrier compartment by means of ventilation ducts connected to the barges, these requirements may be reduced or waived to the satisfaction of the *Register*.
- Special category spaces shall be treated as closed ro-ro spaces when dangerous goods are carried.

Table 19.2

Application of the special requirements to different classes of dangerous goods for ships and cargo spaces carrying solid dangerous goods in bulk

| Class Requirements in Section 19 | 4.1 | 4.2 | 4.3⁶ | 5.1 | 6.1 | 8 | 9 |
|---|----------------|----------------|------------------------|------------------|------------|----------|------------------|
| .3.1.1 | X | X | – | X | – | – | X |
| .3.1.2 | X | X | – | X | – | – | X |
| .3.2 | X | X ⁷ | X | X ⁸ | – | – | X ⁸ |
| .3.4.1 | – | X ⁷ | X | – | – | – | – |
| .3.4.2 | X ⁹ | X ⁷ | X | X ^{7,9} | – | – | X ^{7,9} |
| .3.4.3 | X | X | X | X | X | X | X |
| .3.6 | X | X | X | X | X | X | X |
| .3.8 | X | X | X | X ⁷ | – | – | X ¹⁰ |

Notes to Table 19.2:

- 6 The hazards of substances in this class which may be carried in bulk are such that special consideration shall be given by the *Register* to the construction and equipment of the ship involved in addition to meeting the requirements enumerated in this table.
- 7 Only applicable to Seedcake containing solvent extractions, to Ammonium nitrate and to Ammonium nitrate fertilizers.
- 8 Only applicable to Ammonium nitrate and to Ammonium nitrate fertilizers. However, a degree of protection in accordance with standards contained in the IEC publication 60079 – Electrical Apparatus for Explosive Gas Atmospheres, is sufficient.
- 9 Only suitable wire mesh guards are required.
- 10 The requirements of the IMSBC Code, as amended, are sufficient.

Table 19.3
Application of the requirements to different classes of dangerous goods except solid dangerous goods in bulk

| Class | 1.1-1.6 | 1.4 S | 2.1 | 2.2 | 2.3 ²⁰ flam- mable | 2.3 non- flam- mable | 3 ¹⁵ | | 4.1 | 4.2 | 4.3 ²¹ liquids | 4.3 solids | 5.1 | 5.2 ¹⁶ | 6.1 ¹⁵ liq- uids<2 3°C | 6.1 ¹⁵ liquids ≥ 23°C ≤ 60°C | 6.1 liquids | 6.1 solids | 8 ¹⁵ liquids < 23°C | 8 ¹⁵ liquids ≥ 23°C ≤ 60°C | 8 liquids | 8 solids | 9 |
|------------|-----------------|-------|-----|-----|-------------------------------------|-------------------------------|-----------------|------------------|-----------------|-----------------|------------------------------|---------------|-----------------|-------------------|--|--|----------------|-----------------|--------------------------------------|--|--------------|-------------|-----------------|
| | | | | | | | < 23°C | ≥ 23°C ≤ 60°C | | | | | | | | | | | | | | | |
| Section 19 | | | | | | | | | | | | | | | | | | | | | | | |
| .3.1.1 | X | X | X | X | X | X | X | X | X | X | X | X | X | X | X | X | X | X | X | X | X | X | X |
| .3.1.2 | X | X | X | X | X | X | X | X | X | X | X | X | X | X | X | X | X | X | X | X | X | X | - |
| .3.1.3 | X | - | - | - | - | - | - | - | - | - | - | - | - | - | - | - | - | - | - | - | - | - | - |
| .3.1.4 | X | - | - | - | - | - | - | - | - | - | - | - | - | - | - | - | - | - | - | - | - | - | - |
| .3.2 | X | - | X | - | X | - | X | - | - | - | X ¹⁸ | - | - | - | - | - | - | - | X | - | - | - | X ¹⁷ |
| .3.3 | X | X | X | X | - | X | X | X | X | X | X | X | X | - | X | X | X | X | X | X | X | X | - |
| .3.4.1 | - | - | X | - | - | X | X | X ¹¹ | X ¹¹ | X ¹¹ | X | X | X ¹¹ | - | X | X | X | X ¹¹ | X | X | - | - | X ¹¹ |
| .3.4.2 | - | - | X | - | - | - | X | - | - | - | - | - | - | - | X | - | - | - | X | - | - | - | X ¹⁷ |
| .3.5 | - | - | - | - | - | - | X | - | - | - | - | - | - | - | X | X | X | - | X | X ¹⁹ | - | - | |
| .3.6 | - | - | X | X | X | X | X | X | X | X | X | X | X | X | X | X | X | X | X | X | X | X | X ¹⁴ |
| .3.7 | - | - | - | - | - | - | X | X | X | X | X | X | X | - | X | X | - | - | X | X | - | - | - |
| .3.8 | X ¹² | - | X | X | X | X | X | X | X | X | X | X | X ¹³ | X | X | X | - | - | X | X | - | - | - |
| .3.9 | X | X | X | X | X | X | X | X | X | X | X | X | X | X | X | X | X | X | X | X | X | X | X |
| .3.10.1 | X | X | X | X | X | X | X | X | X | X | X | X | X | X | X | X | X | X | X | X | X | X | X |
| .3.10.2 | X | X | X | X | X | X | X | X | X | X | X | X | X | X | X | X | X | X | X | X | X | X | X |

Notes to Table 19.3:

- 11 When “mechanically-ventilated spaces” are required by IMDG Code, as amended.
- 12 Stow 3 m horizontally away from the machinery space boundaries in all cases.
- 13 Reference is made to the IMDG Code, as amended.
- 14 As appropriate for the goods to be carried.
- 15 Indicated temperature refers to the flashpoint.
- 16 Under the provisions of the IMDG Code, as amended, stowage of class 5.2 dangerous goods under deck or in enclosed ro-ro spaces is prohibited.
- 17 Only applicable to dangerous goods evolving flammable vapour listed in the IMDG Code, as amended.
- 18 Only applicable to dangerous goods having a flashpoint less than 23°C listed in the IMDG Code, as amended.
- 19 Only applicable to dangerous goods having a subsidiary risk class 6.1.
- 20 Under the provisions of the IMDG Code, stowage of class 2.3 having subsidiary risk class 2.1 under deck or in enclosed ro-ro spaces is prohibited.
- 21 Under the provisions of the IMDG Code, stowage of class 4.3 liquids having a flashpoint less than 23°C under deck or in enclosed ro-ro spaces is prohibited.

20 PROTECTION OF VEHICLE, SPECIAL CATEGORY AND RO-RO SPACES

20.1 PURPOSE

20.1.1 The purpose of this Section is to provide additional safety measures in order to address the fire safety objectives of this Rules for the classification of ships for ships fitted with vehicle, special category and ro-ro spaces. For this purpose, the following functional requirements shall be met:

- .1 fire protection systems shall be provided to adequately protect the ship from the fire hazards associated with vehicle, special category and ro-ro spaces;
- .2 ignition sources shall be separated from vehicle, special category and ro-ro spaces; and
- .3 vehicle, special category and ro-ro spaces shall be adequately ventilated.

20.2 GENERAL REQUIREMENTS

20.2.1 Application

20.2.1.1 In addition to complying with the requirements of Sections 3 to 16, as appropriate, vehicle, special category and ro-ro spaces shall comply with the requirements of this Section.

For existing vehicle carriers carrying motor vehicles with compressed hydrogen or natural gas in their tanks for their own propulsion as cargo see 20.2.3.

20.2.1.2 On all ships, vehicles with fuel in their tanks for their own propulsion may be carried in cargo spaces other than vehicle, special category or ro-ro spaces, provided that all the following conditions are met:

- .1 the vehicles do not use their own propulsion within the cargo spaces;
- .2 the cargo spaces are in compliance with the appropriate requirements of Section 19; and
- .3 the vehicles are carried in accordance with the IMDG Code, as defined in SOLAS, Regulation VII/1.1.

20.2.2 Basic principles for passenger ships

20.2.2.1 The basic principle underlying the provisions of this Section is that the main vertical zoning required by 9.2 may not be practicable in vehicle spaces of passenger ships and, therefore, equivalent protection must be obtained in such spaces on the basis of a horizontal zone concept and by the provision of an efficient fixed fire-extinguishing system. Based on this concept, a horizontal zone for the purpose of this Section may include special category spaces on more than one deck provided that the total overall clear height for vehicles does not exceed 10 m. See *IACS UI SC158 Rev.1*.

20.2.2.2 The basic principle underlying the provisions of 20.2.2.1 is also applicable to ro-ro spaces.

20.2.2.3 The requirements of ventilation systems, openings in ‘‘A’’ class divisions and penetrations in ‘‘A’’ class divisions for maintaining the integrity of vertical zones in this Rules for the classification of ships shall be applied equally to decks and bulkheads forming the boundaries separating horizontal zones from each other and from the remainder of the ship.

20.2.3 Additional requirements for existing vehicle carriers carrying motor vehicles with compressed hydrogen or natural gas in their tanks

20.2.3.1 Requirements set in *MSC.1/Circ.1471* shall be applied:

- .1 The carriage of vehicles with compressed hydrogen or compressed natural gas in their tanks for their own propulsion should be to the satisfaction of the Administration, taking into account SOLAS regulation II-2/20-1 and SP 961 and SP 962 of the IMDG Code, as applicable.
- .2 The shipper shall provide a signed certificate or declaration that the vehicle fuel system, as offered for carriage, has been checked for leak-tightness and the vehicle is in proper condition for carriage prior to loading. In addition, the shipper is to mark, label or placard each vehicle, after it has been checked for leak-tightness and that it is in proper condition for carriage. During loading, the crew should check each vehicle for the shipper's markings.

20.3 PRECAUTION AGAINST IGNITION OF FLAMMABLE VAPOURS IN CLOSED VEHICLE SPACES, CLOSED RO-RO SPACES AND SPECIAL CATEGORY SPACES

20.3.1 Ventilation systems

See *Revised Design Guidelines and operational recommendations for ventilation systems in ro-ro cargo spaces (MSC.1/Circ.1515)*.

20.3.1.1 Capacity of ventilation systems

There shall be provided an effective power ventilation system sufficient to give at least the following air changes:

- .1 Passenger ships:

| | |
|---|-------------------------|
| Special category spaces | 10 air changes per hour |
| Closed ro-ro and vehicle spaces other than special category spaces for ships carrying more than 36 passengers | 10 air changes per hour |
| Closed ro-ro and vehicle spaces other than special category spaces for ships carrying not more than 36 passengers | 6 air changes per hour |

.2 Cargo ships: 6 air changes per hour

The *Register* may require an increased number of air changes when vehicles are being loaded and unloaded.

20.3.1.2 Performance of ventilation systems

20.3.1.2.1 In passenger ships, the power ventilation system shall be separate from other ventilation systems. The power ventilation system shall be operated to give at least the number of air changes required in 20.3.1.1 at all times when vehicles are in such spaces, except where an air quality control system in accordance with 20.3.1.2.4 is provided. Ventilation ducts serving such cargo spaces capable of being effectively sealed shall be separated for each such space. The system shall be capable of being controlled from a position outside such spaces.

20.3.1.2.2 In cargo ships, the ventilation fans shall normally be run continuously and give at least the number of air changes required in 20.3.1.1 whenever vehicles are on board, except where an air quality control system in accordance with 20.3.1.2.4 is provided. Where this is impracticable, they shall be operated for a limited period daily as weather permits and in any case for a reasonable period prior to discharge, after which period the ro-ro or vehicle space shall be proved gas-free. One or more portable combustible gas detecting instruments shall be carried for this purpose. The system shall be entirely separate from other ventilation systems. Ventilation ducts serving ro-ro or vehicle spaces shall be capable of being effectively sealed for each cargo space. The system shall be capable of being controlled from a position outside such spaces.

20.3.1.2.3 The ventilation system shall be such as to prevent air stratification and the formation of air pockets.

20.3.1.2.4 For all ships, where an air quality control system is provided based on the guidelines developed by the IMO, see *Revised design guidelines and operational recommendations for ventilation systems in ro-ro cargo spaces (MSC/Circ.1515)*, the ventilation system may be operated at a decreased number of air changes and/or a decreased amount of ventilation. This relaxation does not apply to spaces to which at least ten air changes per hour is required by 20.3.2.2 and spaces subject to 19.3.4.1 and 20-1.

20.3.1.3 Indication of ventilation systems

Means shall be provided on the navigation bridge to indicate any loss of the required ventilating capacity.
See *IACS UI SC75 Rev.1*.

20.3.1.4 Closing appliances and ducts

20.3.1.4.1 Arrangements shall be provided to permit a rapid shutdown and effective closure of the ventilation system from outside of the space in case of fire, taking into account the weather and sea conditions. See *IACS UI SC243 Rev.1*. See also *MSC.1/Circ.1434*.

20.3.1.4.2 Ventilation ducts, including dampers, within a common horizontal zone shall be made of steel. In passenger ships, ventilation ducts that pass through other horizontal zones or machinery spaces shall be "A-60" class steel ducts constructed in accordance with 9.7.2.4.1.1 and 9.7.2.4.1.2.

20.3.1.5 Permanent openings

Permanent openings in the side plating, the ends or deckhead of the space shall be so situated that a fire in the cargo space does not endanger stowage areas and embarkation stations for survival craft and accommodation spaces, service spaces and control stations in superstructures and deckhouses above the cargo spaces.

20.3.2 Electrical equipment and wiring

20.3.2.1 Except as provided in 20.3.2.2, electrical equipment and wiring shall be of a type suitable for use in an explosive petrol and air mixture, see *recommendations of the International Electrotechnical Commission, in particular publication 60079, Electrical apparatus for explosive gas atmospheres*.

See also *IACS UI SC43, Rev.3*.

20.3.2.2 In case of other than special category spaces below the bulkhead deck, notwithstanding the provisions in 20.3.2.1, above a height of 450 mm from the deck and from each platform for vehicles, if fitted, except platforms with openings of sufficient size permitting penetration of petrol gases downwards, electrical equipment of a type so enclosed and protected as to prevent the escape of sparks shall be permitted as an alternative, on condition that the ventilation system is so designed and operated as to provide continuous ventilation of the cargo spaces at the rate of at least ten air changes per hour whenever vehicles are on board.

See *IACS UI SC42, Rev.3*.

20.3.3 Electrical equipment and wiring in exhaust ventilation ducts

Electrical equipment and wiring, if installed in an exhaust ventilation duct, shall be of a type approved for use in explosive petrol and air mixtures and the outlet from any exhaust duct shall be sited in a safe position, having regard to other possible sources of ignition.

See *IACS UI SC43, Rev.3*.

20.3.4 Other ignition sources

Other equipment which may constitute a source of ignition of flammable vapours shall not be permitted.

20.3.5 Scuppers and discharges

Scuppers shall not be led to machinery or other spaces where sources of ignition may be present.

20.4 DETECTION AND ALARM

See *IACS UI SC73 Rev.2*.

20.4.1 Fixed fire detection and fire alarm systems

Except as provided in 20.4.3.1, there shall be provided a fixed fire detection and fire alarm system complying with the requirements of the Section 24. The fixed fire detection system shall be capable of rapidly detecting the onset of fire. The type of detectors and their spacing and location shall be to the satisfaction of the *Register*, taking into account the effects of ventilation and other relevant factors. After being installed, the system shall be tested under normal ventila-

tion conditions and shall give an overall response time to the satisfaction of the *Register*.

20.4.2 Sample extraction smoke detection systems

Except open ro-ro spaces, open vehicle spaces and special category spaces, a sample extraction smoke detection system complying with the requirements of the Section 24 may be used as an alternative for the fixed fire detection and fire alarm system required in 20.4.1.

20.4.3 Special category spaces

20.4.3.1 An efficient fire patrol system shall be maintained in special category spaces. If an efficient fire patrol system is maintained by a continuous fire watch at all times during the voyage, a fixed fire detection and fire alarm system is not required.

20.4.3.2 Manually operated call points shall be spaced so that no part of the space is more than 20 m from a manually operated call point, and one shall be placed close to each exit from such spaces.

20.5 STRUCTURAL FIRE PROTECTION

20.5.1 Notwithstanding the provisions of 9.2.2, in passenger ships carrying more than 36 passengers, the boundary bulkheads and decks of special category spaces and ro-ro spaces shall be insulated to "A-60" class standard. However, where a category (5), (9) or (10) space, as defined in 9.2.2.3, is on one side of the division, the standard may be reduced to "A-0". Where fuel oil tanks are below a special category space or a ro-ro space, the integrity of the deck between such spaces may be reduced to "A-0" standard.

20.6 FIRE EXTINGUISHING

See *IACS UI SC73 Rev.2*.

20.6.1 Fixed fire-extinguishing systems

The requirements of 20.6.1.1 and 20.6.1.2 shall apply to ships constructed on or after 1 July 2014. Ships constructed before 1 July 2014 shall comply with the previously applicable requirements of the Rules for the classification of ships.

20.6.1.1 Vehicle spaces and ro-ro spaces, which are not special category spaces and are capable of being sealed from a location outside of the cargo spaces, shall be fitted with one of the following fixed fire-extinguishing systems:

- .1 a fixed gas fire-extinguishing system complying with the provisions of the Section 24;
- .2 a fixed high-expansion foam fire-extinguishing system complying with the provisions of the Section 24; or
- .3 a fixed water-based fire-fighting system for ro-ro spaces and special category spaces complying with the provisions of the Section 24 and 20.6.1.2.1 to 20.6.1.2.4.

20.6.1.2 Vehicle spaces and ro-ro spaces not capable of being sealed and special category spaces shall be fitted with a

fixed water-based fire-fighting system for ro-ro spaces and special category spaces complying with the provisions of the Section 24 which shall protect all parts of any deck and vehicle platform in such spaces. Such a water-based fire-fighting system shall have:

- .1 a pressure gauge on the valve manifold;
- .2 clear marking on each manifold valve indicating the spaces served;
- .3 instructions for maintenance and operation located in the valve room; and
- .4 a sufficient number of drainage valves to ensure complete drainage of the system.

20.6.1.3 The *Register* may permit the use of any other fixed fire-extinguishing system (see *Guidelines for the approval of fixed water-based fire-fighting systems for ro-ro spaces and special category spaces equivalent to that referred to in resolution A.123(V) (MSC.1/Circ.1272)* and *Revised Guidelines for the design and approval of fixed water-based fire-fighting systems for ro-ro spaces and special category spaces (MSC.1/Circ.1430, Rev.3)*) that has been shown, by a full-scale test in conditions simulating a flowing petrol fire in a vehicle space or a ro-ro space, to be not less effective in controlling fires likely to occur in such a space.

20.6.1.4 When fixed pressure water-spraying systems are fitted, in view of the serious loss of stability which could arise due to large quantities of water accumulating on the deck or decks during the operation of the fixed pressure water-spraying system, the following arrangements shall be provided:

- .1 in passenger ships:
 - .1.1 in the spaces above the bulkhead deck, scuppers shall be fitted so as to ensure that such water is rapidly discharged directly overboard, taking into account the guidelines developed by the IMO, see *Guidelines for the drainage of fire-fighting water from closed vehicle and ro-ro spaces and special category spaces of passenger and cargo ships (MSC.1/Circ.1320)*;
 - .1.2(1) in ro-ro passenger ships, discharge valves for scuppers, fitted with positive means of closing operable from a position above the bulkhead deck in accordance with the requirements of the International Convention on Load Lines in force, shall be kept open while the ships are at sea;
 - .1.2(2) any operation of valves referred to in 20.6.1.4.1.2(1) shall be recorded in the logbook;
 - .1.3 in the spaces below the bulkhead deck, the *Register* may require pumping and drainage facilities to be provided additional to the requirements of other relevant Parts of the Rules for the classification of ships. In such case, the drainage system shall be sized to remove no less than 125% of the combined capacity of both the water-spraying

system pumps and the required number of fire hose nozzles, taking into account the guidelines developed by the IMO, see *Guidelines for the drainage of fire-fighting water from closed vehicle and ro-ro spaces and special category spaces of passenger and cargo ships (MSC.1/Circ.1320)*. The drainage system valves shall be operable from outside the protected space at a position in the vicinity of the extinguishing system controls. Bilge wells shall be of sufficient holding capacity and shall be arranged at the side shell of the ship at a distance from each other of not more than 40 m in each watertight compartment;

- .2 in cargo ships, the drainage and pumping arrangements shall be such as to prevent the build-up of free surfaces. In such case, the drainage system shall be sized to remove no less than 125% of the combined capacity of both the water-spraying system pumps and the required number of fire hose nozzles, taking into account the guidelines developed by the IMO, see *Guidelines for the drainage of fire-fighting water from closed vehicle and ro-ro spaces and special category spaces of passenger and cargo ships (MSC.1/Circ.1320)*. The drainage system valves shall be operable from outside the protected space at a position in the vicinity of the extinguishing system controls. Bilge wells shall be of sufficient holding capacity and shall be arranged at the side shell of the ship at a distance from each other of not more than 40 m in each watertight compartment. If this is not possible, the adverse effect upon stability of the added weight and free surface of water shall be taken into account to the extent deemed necessary by the Register in its approval of the stability information, see *Recommendation on fixed fire-extinguishing systems for special category spaces (resolution A.123(V))*. Such information shall be included in the stability information supplied to the master as required by the *Rules for the classification of ships, Part 4 - Stability, 1.5*.

20.6.1.5 On all ships, for closed vehicles and ro-ro spaces and special category spaces, where fixed pressure water-spraying systems are fitted, means shall be provided to prevent the blockage of drainage arrangements, taking into account the guidelines developed by the IMO, see *Guidelines for the drainage of fire-fighting water from closed vehicle and ro-ro spaces and special category spaces of passenger and cargo ships (MSC.1/Circ.1320)*. This requirement shall be applied to new ships and existing ships.

20.6.2 Portable fire extinguishers

See *IACS UI SC205*.

20.6.2.1 Portable fire extinguishers shall be provided at each deck level in each hold or compartment where vehicles are carried, spaced not more than 20 m apart on both sides of the space. At least one portable fire extinguisher shall be located at each access to such a cargo space, see *Unified interpretation of SOLAS Chapter II-2 on the number and arrangement of portable fire extinguishers on board ships (MSC.1/Circ.1275 and MSC.1/Circ.1275/Corr.1.)*.

20.6.2.2 In addition to the provision of 20.6.2.1, the following fire-extinguishing appliances shall be provided in vehicle, ro-ro and special category spaces intended for the carriage of motor vehicles with fuel in their tanks for their own propulsion:

- .1 at least three water-fog applicators; and
- .2 one portable foam applicator unit complying with the provisions of the Section 24, provided that at least two such units are available in the ship for use in such spaces.

20-1 REQUIREMENTS FOR VEHICLE CARRIERS CARRYING MOTOR VEHICLES WITH COMPRESSED HYDROGEN OR NATURAL GAS IN THEIR TANKS FOR THEIR OWN PROPULSION AS CARGO

20-1.1 PURPOSE

20-1.1.1 The purpose of this Section is to provide additional safety measures in order to address the fire safety objectives of this Part of the Rules for the classification of ships for vehicle carriers with vehicle and ro-ro spaces intended for carriage of motor vehicles with compressed hydrogen or compressed natural gas in their tanks for their own propulsion as cargo.

20-1.2 APPLICATION

20-1.2.1 In addition to complying with the requirements of Section 20, as appropriate, vehicle carriers intended for the carriage of motor vehicles with compressed hydrogen or compressed natural gas in their tanks for their own propulsion as cargo shall comply with the requirements in 20-1.3 to 20-1.5.

20-1.2.2 In addition to complying with the requirements of Section 20, as appropriate, vehicle carriers constructed before 1 January 2016, including those constructed before 1 July 2012, shall comply with the requirements in 20-1.5.

See *Recommendation on safety measures for existing vehicle carriers carrying motor vehicles with compressed hydrogen or natural gas in their tanks for their own propulsion as cargo (MSC.1/Circ.1471)*.

20-1.3 REQUIREMENTS FOR SPACES INTENDED FOR CARRIAGE OF MOTOR VEHICLES WITH COMPRESSED NATURAL GAS IN THEIR TANKS FOR THEIR OWN PROPULSION AS CARGO

20-1.3.1 Electrical equipment and wiring

All electrical equipment and wiring shall be of a certified safe type for use in an explosive methane and air mixture, see *recommendations of the International Electrotechnical Commission*, in particular, *publication IEC 60079*.

20-1.3.2 Ventilation arrangement

20-1.3.2.1 Electrical equipment and wiring, if installed in any ventilation duct, shall be of a certified safe type for use in explosive methane and air mixtures.

20-1.3.2.2 The fans shall be such as to avoid the possibility of ignition of methane and air mixtures. Suitable wire mesh

guards shall be fitted over inlet and outlet ventilation openings.

20-1.3.3 Other ignition sources

Other equipment which may constitute a source of ignition of methane and air mixtures shall not be permitted.

20-1.4 REQUIREMENTS FOR SPACES INTENDED FOR CARRIAGE OF MOTOR VEHICLES WITH COMPRESSED HYDROGEN IN THEIR TANKS FOR THEIR OWN PROPULSION AS CARGO

20-1.4.1 Electrical equipment and wiring

All electrical equipment and wiring shall be of a certified safe type for use in an explosive hydrogen and air mixture, see *recommendations of the International Electrotechnical Commission*, in particular, *publication IEC 60079*.

20-1.4.2 Ventilation arrangement

20-1.4.2.1 Electrical equipment and wiring, if installed in any ventilation duct, shall be of a certified safe type for use in explosive hydrogen and air mixtures and the outlet from any exhaust duct shall be sited in a safe position, having regard to other possible sources of ignition.

20-1.4.2.2 The fans shall be designed such as to avoid the possibility of ignition of hydrogen and air mixtures. Suitable wire mesh guards shall be fitted over inlet and outlet ventilation openings.

20-1.4.3 Other ignition sources

Other equipment which may constitute a source of ignition of hydrogen and air mixtures shall not be permitted.

20-1.5 DETECTION

When a vehicle carrier carries as cargo one or more motor vehicles with either compressed hydrogen or compressed natural gas in their tanks for their own propulsion, at least two portable gas detectors shall be provided. Such detectors shall be suitable for the detection of the gas fuel and be of a certified safe type for use in the explosive gas and air mixture.

21 CASUALTY THRESHOLD, SAFE RETURN TO PORT AND SAFE AREAS

21.1 APPLICATION

21.1.1 Passenger ships constructed on or after 1 July 2010 having a length, as defined in the *Rules for the classification of ships, Part 5 – Subdivision*, 1.2, of 120 m or more or having three or more main vertical zones shall comply with the provisions of this Section.

However, main vertical zones at the foremost and/or aftermost part of the ship, comprising only voids without normal means of access or ballast tanks, for example fore-peak, need not be included in the count of the main vertical zones.

21.2 GENERAL REQUIREMENTS

21.2.1 The purpose of this Section is to establish design criteria for a ship's safe return to port under its own propulsion after a casualty that does not exceed the casualty threshold stipulated in 21.3 and also provides functional requirements and performance standards for safe areas.

21.3 CASUALTY THRESHOLD

21.3.1 The casualty threshold, in the context of a fire, includes:

- .1 loss of space of origin up to the nearest "A" class boundaries, which may be a part of the space of origin, if the space of origin is protected by a fixed fire-extinguishing system; or
- .2 loss of the space of origin and adjacent spaces up to the nearest "A" class boundaries which are not part of the space of origin.

21.4 SAFE RETURN TO PORT

21.4.1 When fire damage does not exceed the casualty threshold indicated in 21.3, the ship shall be capable of returning to port while providing a safe area as defined in 3.51. To be deemed capable of returning to port, the following systems shall remain operational in the remaining part of the ship not affected by fire (see *MSC.1/Circ.1369, MSC.1/Circ.1369/Add.1 and MSC.1/Circ.1437*):

- .1 propulsion;
- .2 steering systems and steering-control systems;
- .3 navigational systems;
- .4 systems for fill, transfer and service of fuel oil;
- .5 internal communication between the bridge, engineering spaces, safety centre, fire-fighting and damage-control teams, and as required for passenger and crew notification and mustering;

- .6 external communication;
 - .7 fire main system;
 - .8 fixed fire-extinguishing systems;
 - .9 fire and smoke detection system;
 - .10 bilge and ballast system;
 - .11 power-operated watertight and semi-watertight doors;
 - .12 systems intended to support "safe areas" as indicated in 21.5.1.2;
 - .13 flooding detection systems; and
 - .14 other systems determined by the *Register* to be vital to damage control efforts.
- See *MSC.1/Circ.1539/Rev.1*.

21.5 SAFE AREA(S)

21.5.1 Functional requirements are:

- .1 the safe area(s) shall generally be an internal space(s); however, the use of an external space as a safe area may be allowed by the *Register* taking into account any restriction due to the area of operation and relevant expected environmental conditions;
- .2 the safe area(s) shall provide all occupants with the following basic services (see *MSC.1/Circ.1369, MSC.1/Circ.1369/Add.1 and MSC.1/Circ.1437*) to ensure that the health of passengers and crew is maintained:
 - .2.1 sanitation;
 - .2.2 water;
 - .2.3 food;
 - .2.4 alternate space for medical care, see 21.5.2;
 - .2.5 shelter from the weather;
 - .2.6 means of preventing heat stress and hypothermia;
 - .2.7 light; and
 - .2.8 ventilation;
- .3 ventilation design shall reduce the risk of smoke and hot gases that could affect the use of the safe area(s); and
- .4 means of access to life-saving appliances shall be provided from each area identified or used as a safe area, taking into account that a main vertical zone may not be available for internal transit.

21.5.2 Alternate space for medical care

Alternate space for medical care shall conform to a standard acceptable to the *Register*, see *Guidance on the establishment of medical and sanitation related programmes for passenger ships (MSC/Circ.1129)*.

22 DESIGN CRITERIA FOR SYSTEMS TO REMAIN OPERATIONAL AFTER A FIRE CASUALTY

22.1 APPLICATION

22.1.1 Passenger ships constructed on or after 1 July 2010 having a length, as defined in the *Rules for the classification of ships, Part 5 – Subdivision*, 1.2, of 120 m or more or having three or more main vertical zones shall comply with the provisions of this Section.

22.2 GENERAL REQUIREMENTS

22.2.1 The purpose of this Section is to provide design criteria for systems required to remain operational for supporting the orderly evacuation and abandonment of a ship, if the casualty threshold, as defined in 21.3, is exceeded.

22.3 SYSTEMS

See *Guidance on the establishment of medical and sanitation related programmes for passenger ships (MSC/Circ.1129); Interim Explanatory Notes for the assessment of passenger ship systems' capabilities after a fire or flooding casualty (MSC.1/Circ.1369 and MSC.1/Circ.1369/Add.1); and MSC.1/Circ.1437.*

22.3.1 In case anyone main vertical zone is unserviceable due to fire, the following systems shall be so arranged and segregated as to remain operational:

- .1 fire main;
- .2 internal communications (in support of firefighting as required for passenger and crew notification and evacuation);
- .3 means of external communications;
- .4 bilge systems for removal of fire-fighting water;
- .5 lighting along escape routes, at assembly stations and at embarkation stations of life-saving appliances; and
- .6 guidance systems for evacuation shall be available.

22.3.2 The above systems shall be capable of operation for at least 3 h based on the assumption of no damage outside the unserviceable main vertical zone. These systems are not required to remain operational within the unserviceable main vertical zones.

22.3.3 Cabling and piping within a trunk constructed to an "A-60" standard shall be deemed to remain intact and serviceable while passing through the unserviceable main vertical zone for the purposes of 22.3.1. An equivalent degree of protection for cabling and piping may be approved by the *Register*.

23 SAFETY CENTRE ON PASSENGER SHIPS

23.1 APPLICATION

23.1.1 Passenger ships constructed on or after 1 July 2010 shall have on board a safety centre complying with the requirements of this Section.

23.2 GENERAL REQUIREMENTS

23.2.1 The purpose of this Section is to provide a space to assist with the management of emergency situations.

23.3 LOCATION AND ARRANGEMENT

23.3.1 The safety centre shall either be a part of the navigation bridge or be located in a separate space adjacent, but having direct access, to the navigation bridge, so that the management of emergencies can be performed without distracting watch officers from their navigational duties.

23.4 LAYOUT AND ERGONOMIC DESIGN

23.4.1 The layout and ergonomic design of the safety centre shall take into account the guidelines developed by the IMO, as appropriate.

23.5 COMMUNICATIONS

23.5.1 Means of communication between the safety centre, the central control station, the navigation bridge, the

engine control room, the storage room(s) for fire-extinguishing system(s) and fire equipment lockers shall be provided.

23.6 CONTROL AND MONITORING OF SAFETY SYSTEMS

23.6.1 Notwithstanding the requirements set out elsewhere in the Convention, the full functionality (operation, control, monitoring or any combination thereof, as required, see *MSC.1/Circ.1368*) of the safety systems listed below shall be available from the safety centre:

- .1 all powered ventilation systems;
- .2 fire doors;
- .3 general emergency alarm system;
- .4 public address system;
- .5 electrically powered evacuation guidance systems;
- .6 watertight and semi-watertight doors;
- .7 indicators for shell doors, loading doors and other closing appliances;
- .8 water leakage of inner/outer bow doors, stern doors and any other shell door;
- .9 television surveillance system;
- .10 fire detection and alarm system;
- .11 fixed fire-fighting local application system(s);
- .12 sprinkler and equivalent systems;
- .13 water-based fire-extinguishing systems for machinery spaces;
- .14 alarm to summon the crew;
- .15 atrium smoke extraction system;
- .16 flooding detection systems; and
- .17 fire pumps and emergency fire pumps.

24 FIRE SAFETY SYSTEMS

24.1 GENERAL REQUIREMENTS

24.1.1 This Section is applicable to fire safety systems as referred to in other Sections of this Part of the Rules for the classification of ships.

24.1.1.1 When reading IACS Unified Interpretations SC or IACS Recommendations that refer to FSS Code, it shall be taken into account that FSS Code item numbers are renumbered in this Section by adding prefix consisting of section and head numbers, e.g. reference in IACS UI SC to FSS Code, Ch.3, 2.1 shall be read as reference to 24.3.2.1.

24.1.2 Definitions

In addition to definitions in 3.1.2, the following definitions apply:

- .1 Convention means the International Convention for the Safety of Life at Sea, 1974, as amended.

24.1.3 Use of equivalents and modern technology

In order to allow modern technology and development of fire safety systems, the *Register* may approve fire safety systems which are not specified in this Section if the requirements of Section 17 are fulfilled.

24.1.4 Use of toxic extinguishing media

The use of a fire-extinguishing medium which, in the opinion of the *Register*, either by itself or under expected conditions of use gives off toxic gases, liquids and other substances in such quantities as to endanger persons shall not be permitted.

24.2 INTERNATIONAL SHORE CONNECTIONS

24.2.1 International shore connection shall be in compliance with requirements in 25.1.18.

24.3 PERSONNEL PROTECTION

24.3.1 Application

This head details the specifications for personnel protection as required by Sections in this Part of the Rules for the classification of ships.

24.3.2 Engineering specifications

24.3.2.1 Fire-fighter's outfit

A fire-fighter's outfit shall consist of a set of personal equipment and a breathing apparatus.

24.3.2.1.1 Personal equipment

Personal equipment shall consist of the following:

- .1 protective clothing of material to protect the skin from the heat radiating from the fire and from burns and scalding by steam. The outer surface shall be water-resistant;
- .2 boots of rubber or other electrically non-conducting material;
- .3 rigid helmet providing effective protection against impact;
- .4 electric safety lamp (hand lantern) of an approved type with a minimum burning period of 3 h. Electric safety lamps on tankers and those intended to be used in hazardous areas shall be of an explosion-proof type, see *recommendations of the International Electrotechnical Commission, in particular publication IEC 60079, Electrical Apparatus for Explosive Gas Atmospheres*; and
- .5 axe with a handle provided with high-voltage insulation.

24.3.2.1.2 Breathing apparatus

- .1 Breathing apparatus shall be a self-contained compressed air breathing apparatus for which the volume of air contained in the cylinders shall be at least 1,200 L, or other self-contained breathing apparatus which shall be capable of functioning for at least 30 min. All air cylinders for breathing apparatus shall be interchangeable.
- .2 Compressed air breathing apparatus shall be fitted with an audible alarm and a visual or other device which will alert the user before the volume of the air in the cylinder has been reduced to no less than 200 L. See *MSC.1/ Circ. 1499*. On ships constructed before 1 July 2014, self-contained compressed air breathing apparatus of fire-fighter's outfits shall also comply with this requirement.

24.3.2.1.3 Lifeline

For each breathing apparatus a fireproof lifeline of at least 30 m in length shall be provided. The lifeline shall successfully pass an approval test by static load of 3.5 kN for 5 min without failure. The lifeline shall be capable of being attached by means of a snap-hook to the harness of the apparatus or to a separate belt in order to prevent the breathing apparatus becoming detached when the lifeline is operated.

24.3.2.2 Emergency escape breathing devices (EEBD)

24.3.2.2.1 General

- .1 An EEBD is a supplied air or oxygen device only used for escape from a compartment that has a hazardous atmosphere and shall be of an approved type.
- .2 EEBDs shall not be used for fighting fires, entering oxygen deficient voids or tanks, or worn by firefighters. In these

events, a self-contained breathing apparatus, which is specifically suited for such applications, shall be used.

24.3.2.2.2 Definitions

- .1 *Face piece* means a face covering that is designed to form a complete seal around the eyes, nose and mouth which is secured in position by a suitable means.
- .2 *Hood* means a head covering which completely covers the head, neck and may cover portions of the shoulders.
- .3 *Hazardous atmosphere* means any atmosphere that is immediately dangerous to life or health.

24.3.2.2.3 Particulars

- .1 The EEBD shall have a service duration of at least 10 min.
- .2 The EEBD shall include a hood or full face piece, as appropriate, to protect the eyes, nose and mouth during escape. Hoods and face pieces shall be constructed of flame-resistant materials and include a clear window for viewing.
- .3 An inactivated EEBD shall be capable of being carried hands-free.
- .4 An EEBD, when stored, shall be suitably protected from the environment.
- .5 Brief instructions or diagrams clearly illustrating their use shall be clearly printed on the EEBD. The donning procedures shall be quick and easy to allow for situations where there is little time to seek safety from a hazardous atmosphere.

24.3.2.2.4 Markings

Maintenance requirements, manufacturer's trademark and serial number, shelf life with accompanying manufacture date and name of the approving authority shall be printed on each EEBD. All EEBD training units shall be clearly marked.

24.4 FIRE EXTINGUISHERS

24.4.1 Application

This head details the specifications for fire extinguishers as required by Sections in this Part of the Rules for the classification of ships.

24.4.2 Type approval

All fire extinguishers shall be of approved types and designs based on the guidelines developed by IMO, see *Improved Guidelines for marine portable fire extinguishers, resolution A.951(23)*.

24.4.3 Engineering specifications

24.4.3.1 Fire extinguishers

24.4.3.1.1 Quantity of medium

- .1 Each powder or carbon dioxide extinguisher shall have a capacity of at least 5 kg and each foam extinguisher shall have a capacity of at least 9 l. The mass of all portable fire extinguishers shall not exceed 23 kg and they shall have a fire-extinguishing capability at least equivalent to that of a 9 l fluid extinguisher.
- .2 The *Register* shall determine the equivalents of fire extinguishers.

24.4.3.1.2 Recharging

Only refills approved for the fire extinguisher in question shall be used for recharging.

24.4.3.2 Portable foam applicators

24.4.3.2.1 A portable foam applicator unit shall consist of a foam nozzle/ branch pipe, either of a self-inducing type or in combination with a separate inductor, capable of being connected to the fire main by a fire hose, together with a portable tank containing at least 20 l of foam concentrate and at least one spare tank of foam concentrate of the same capacity.

For additional requirements to be complied with see 25.1.7.

24.4.3.2.2 System performance

- .1 The nozzle/branch pipe and inductor shall be capable of producing effective foam suitable for extinguishing an oil fire, at a foam solution flow rate of at least 200 l/min at the nominal pressure in the fire main.
- .2 The foam concentrate shall be approved by the *Register* based on *Revised guidelines for the performance and testing criteria, and surveys of foam concentrates for fixed fire-extinguishing systems (MSC.1/Circ.1312 and MSC.1/Circ.1312/Corr.1)*.
- .3 The values of the foam expansion and drainage time of the foam produced by the portable foam applicator unit shall not differ more than $\pm 10\%$ of that determined in 24.4.3.2.2.2.
- .4 The portable foam applicator unit shall be designed to withstand clogging, ambient temperature changes, vibration, humidity, shock, impact and corrosion normally encountered on ships.

24.5 FIXED GAS FIRE-EXTINGUISHING SYSTEMS

24.5.1 Application

This head details the specifications for fixed gas fire-extinguishing systems as required by Sections in this Part of the Rules for the classification of ships. See *IACS UI SC200, Corr.1* (taking into account 24.1.1.1).

24.5.2 Engineering specifications

24.5.2.1 General

24.5.2.1.1 Fire-extinguishing medium

- .1 Where the quantity of the fire-extinguishing medium is required to protect more than one space, the quantity of medium available need not be more than the largest quantity required for any one space so protected. The system shall be fitted with normally closed control valves arranged to direct the agent into the appropriate space. Adjacent spaces with independent ventilation systems not separated by at least A-0 class divisions should be considered as the same space.
- .2 The volume of starting air receivers, converted to free air volume, shall be added to the gross volume of the machinery space when calculating the necessary quantity of the fire-extinguishing medium. Alternatively, a discharge pipe from the safety valves may be fitted and led directly to the open air.
- .3 Means shall be provided for the crew to safely check the quantity of the fire-extinguishing medium in the containers. It shall not be necessary to move the containers completely from their fixing position for this purpose. For carbon dioxide systems, hanging bars for a weighing device above each bottle row, or other means shall be provided. For other types of extinguishing media, suitable surface indicators may be used.
- .4 Containers for the storage of fire-extinguishing medium, piping and associated pressure components shall be designed to pressure codes of practice to the satisfaction of the *Register* having regard to their locations and maximum ambient temperatures expected in service.

24.5.2.1.2 Installation requirements

- .1 The piping for the distribution of fire-extinguishing medium shall be arranged and discharge nozzles so positioned that a uniform distribution of the medium is obtained. System flow calculations shall be performed using a calculation technique acceptable to the *Register*.

- .2 Except as otherwise permitted by the *Register*, pressure containers required for the storage of fire-extinguishing medium, other than steam, shall be located outside the protected spaces in accordance with regulation II-2/10.4.3 of the Convention.
- .3 Spare parts for the system shall be stored on board and be to the satisfaction of the *Register*.
- .4 In piping sections where valve arrangements introduce sections of closed piping, such sections shall be fitted with a pressure relief valve and the outlet of the valve shall be led to open deck.
- .5 All discharge piping, fittings and nozzles in the protected spaces shall be constructed of materials having a melting temperature which exceeds 925°C. The piping and associated equipment shall be adequately supported.
- .6 A fitting shall be installed in the discharge piping to permit the air testing as required by 24.5.2.2.3.1.

24.5.2.1.3 System control requirements

- .1 The necessary pipes for conveying fire-extinguishing medium into the protected spaces shall be provided with control valves so marked as to indicate clearly the spaces to which the pipes are led. Suitable provisions shall be made to prevent inadvertent release of the medium into the space. Where a cargo space fitted with a gas fire-extinguishing system is used as a passenger space, the gas connection shall be blanked during such use. The pipes may pass through accommodations providing that they are of substantial thickness and that their tightness is verified with a pressure test, after their installation, at a pressure head not less than 5 N/mm². In addition, pipes passing through accommodation areas shall be joined only by welding and shall not be fitted with drains or other openings within such spaces. The pipes shall not pass through refrigerated spaces.
- .2 Means shall be provided for automatically giving audible and visual warning of the release of fire-extinguishing medium into any ro-ro spaces, container holds equipped with integral reefer containers, spaces accessible by doors or hatches, and other spaces in which personnel normally work or to which they have access. See *IACS UI SC25 Rev.2*, *IACS UI SC132 Rev.4* and *IACS UI SC252* (taking into account 24.1.1.1). The audible alarms shall be located so as to be audible throughout the protected space with all machinery operating, and the alarms should be distinguished from other audible alarms by adjustment of sound pressure or sound patterns. The pre-discharge

alarm shall be automatically activated (e.g. by opening of the release cabinet door). The alarm shall operate for the length of time needed to evacuate the space, but in no case less than 20 s before the medium is released. Conventional cargo spaces and small spaces (such as compressor rooms, paint lockers, etc.) with only a local release need not be provided with such an alarm. See *MSC.1/Circ.1456 and MSC.1/Circ.1487*.

- .3 The means of control of any fixed gas fire-extinguishing system shall be readily accessible, simple to operate and shall be grouped together in as few locations as possible at positions not likely to be cut off by a fire in a protected space. At each location there shall be clear instructions relating to the operation of the system having regard to the safety of personnel. See *MSC.1/Circ.1240*. See *IACS UI SC204, Corr.1* (taking into account 24.1.1.1).
- .4 Automatic release of fire-extinguishing medium shall not be permitted, except as permitted by the *Register*.

24.5.2.2 Carbon dioxide systems

Where a low-pressure CO₂ system is fitted, the piping system is to be designed in such a way that the CO₂ pressure at the nozzles should not be less than 1 N/mm².

24.5.2.2.1 Quantity of fire-extinguishing medium

- .1 For cargo spaces, the quantity of carbon dioxide available shall, unless otherwise provided, be sufficient to give a minimum volume of free gas equal to 30% of the gross volume of the largest cargo space to be protected in the ship.
- .2 For vehicle spaces and ro-ro spaces which are not special category spaces, the quantity of carbon dioxide available shall be at least sufficient to give a minimum volume of free gas equal to 45% of the gross volume of the largest such cargo space which is capable of being sealed, and the arrangements shall be such as to ensure that at least two thirds of the gas required for the relevant space shall be introduced within 10 min. Carbon dioxide systems shall not be used for the protection of special category spaces.
- .3 For machinery spaces, the quantity of carbon dioxide carried shall be sufficient to give a minimum volume of free gas equal to the larger of the following volumes, either:
 - (1) 40% of the gross volume of the largest machinery space so protected, the volume to exclude that part of the casing above the level at which the horizontal area of the casing is 40% or less of the horizontal area of the space concerned taken midway be-

tween the tank top and the lowest part of the casing; or

- (2) 35% of the gross volume of the largest machinery space protected, including the casing.
- .4 The percentages specified in 24.5.2.2.1.3 above may be reduced to 35% and 30%, respectively, for cargo ships of less than 2,000 gross tonnage where two or more machinery spaces, which are not entirely separate, are considered as forming one space.
- .5 For the purpose of this Section the volume of free carbon dioxide shall be calculated at 0.56 m³/kg.
- .6 For machinery spaces, the fixed piping system shall be such that 85% of the gas can be discharged into the space within 2 min.
- .7 For container and general cargo spaces (primarily intended to carry a variety of cargoes separately secured or packed), the fixed piping system shall be such that at least two thirds of the gas can be discharged into the space within 10 min. For solid bulk cargo spaces, the fixed piping system shall be such that at least two thirds of the gas can be discharged into the space within 20 min. The system controls shall be arranged to allow one third, two thirds or the entire quantity of gas to be discharged based on the loading condition of the hold. See *MSC.1/Circ.1528*.
- .8 In containerships, for container cargo spaces fitted with partially weathertight hatchway covers the quantity of carbon dioxide available for the cargo space shall be increased as specified in *MSC/Circ.1087*.

24.5.2.2.2 Controls

Carbon dioxide systems for the protection of ro-ro spaces, container holds equipped with integral reefer containers, spaces accessible by doors or hatches, and other spaces in which personnel normally work or to which they have access shall comply with the following requirements:

- .1 two separate controls shall be provided for releasing carbon dioxide into a protected space and to ensure the activation of the alarm. One control shall be used for opening the valve of the piping which conveys the gas into the protected space and a second control shall be used to discharge the gas from its storage containers. Positive means shall be provided so they can only be operated in that order; and
- .2 the two controls shall be located inside a release box clearly identified for the particular space. If the box containing the controls is to be locked, a key to the box shall be in a break-glass-type enclosure conspicuously located adjacent to the box.

See *IACS UI SC 132, Rev. 4* and *IACS UI SC 252* (taking into account 24.1.1.1). See also *MSC.1/Circ.1456*.

24.5.2.2.3 Testing of the installation

When the system has been installed, pressure-tested and inspected, the following shall be carried out:

- .1 a test of the free air flow in all pipes and nozzles; and
- .2 a functional test of the alarm equipment.

24.5.2.2.4 Low-pressure CO₂ systems

Where a low pressure CO₂ system is fitted to comply with this regulation, the following applies.

- .1 The system control devices and the refrigerating plants shall be located within the same room where the pressure vessels are stored.
- .2 The rated amount of liquid carbon dioxide shall be stored in vessel(s) under the working pressure in the range of 1.8 N/mm² to 2.2 N/mm². The normal liquid charge in the container shall be limited to provide sufficient vapour space to allow for expansion of the liquid under the maximum storage temperatures than can be obtained corresponding to the setting of the pressure relief valves but shall not exceed 95% of the volumetric capacity of the container.
- .3 Provision shall be made for:
 - (1) pressure gauge;
 - (2) high pressure alarm: not more than setting of the relief valve;
 - (3) low pressure alarm: not less than 1.8 N/mm²;
 - (4) branch pipes with stop valves for filling the vessel;
 - (5) discharge pipes;
 - (6) liquid CO₂ level indicator, fitted on the vessel(s); and
 - (7) two safety valves.
- .4 The two safety relief valves shall be arranged so that either valve can be shut off while the other is connected to the vessel. The setting of the relief valves shall not be less than 1.1 times the working pressure. The capacity of each valve shall be such that the vapours generated under fire conditions can be discharged with a pressure rise not more than 20% above the setting pressure. The discharge from the safety valves shall be led to the open.
- .5 The vessel(s) and outgoing pipes permanently filled with carbon dioxide shall have thermal insulation preventing the operation of the safety valve in 24 h after de-energizing the plant, at ambient temperature of 45°C and an initial pressure equal to the starting pressure of the refrigeration unit.
- .6 The vessel(s) shall be serviced by two automated completely independent refrigerating units solely intended for this purpose, each comprising a compressor and

the relevant prime mover, evaporator and condenser.

- .7 The refrigerating capacity and the automatic control of each unit shall be so as to maintain the required temperature under conditions of continuous operation during 24 h at sea temperatures up to 32°C and ambient air temperatures up to 45°C.
- .8 Each electric refrigerating unit shall be supplied from the main switchboard bus-bars by a separate feeder.
- .9 Cooling water supply to the refrigerating plant (where required) shall be provided from at least two circulating pumps one of which being used as a stand-by. The stand-by pump may be a pump used for other services so long as its use for cooling would not interfere with any other essential service of the ship. Cooling water shall be taken from not less than two sea connections, preferably one port and one starboard.
- .10 Safety relief devices shall be provided in each section of pipe that may be isolated by block valves and in which there could be a buildup of pressure in excess of the design pressure of any of the components.
- .11 Audible and visual alarms shall be given in a central control station or where a central control station is not provided, when:
 - (1) the pressure in the vessel(s) reaches the low and high values according to 24.5.2.2.4.2;
 - (2) any one of the refrigerating units fails to operate; or
 - (3) the lowest permissible level of the liquid in the vessels is reached.
- .12 If the system serves more than one space, means for control of discharge quantities of CO₂ shall be provided, e.g. automatic timer or accurate level indicators located at the control position(s).
- .13 If a device is provided which automatically regulates the discharge of the rated quantity of carbon dioxide into the protected spaces, it shall be also possible to regulate the discharge manually.

24.5.2.3 Requirements of steam systems

The boiler or boilers available for supplying steam shall have an evaporation of at least 1 kg of steam per hour for each 0.75 m³ of the gross volume of the largest space so protected. In addition to complying with the foregoing requirements, the systems in all respects shall be as determined by, and to the satisfaction of, the *Register*.

24.5.2.4 Equivalent fixed gas fire-extinguishing systems for machinery spaces and cargo pump rooms

Fixed gas fire-extinguishing systems equivalent to those specified in 24.5.2.2 and 24.5.2.3 shall be approved by the *Register* based on the guidelines developed by the IMO, see *Revised guidelines for the approval of equivalent fixed gas fire-extinguishing systems, as referred to in SOLAS*

74, for machinery spaces and cargo pump-rooms (MSC/Circ.848), MSC.1/Circ.1267, MSC.1/Circ.1316, MSC.1/Circ.1317 and the Guidelines for the approval of fixed aerosol fire-extinguishing systems equivalent to fixed gas fire-extinguishing systems, as referred to in SOLAS 74, for machinery spaces (MSC/Circ.1007). See 24.20.

24.6 FIXED FOAM FIRE-EXTINGUISHING SYSTEMS

24.6.1 Application

This head details the specifications for fixed foam fire-extinguishing systems for the protection of machinery spaces in accordance with 10.4.1.1.2, cargo spaces in accordance with 10.7.1.1, cargo pump rooms in accordance with 10.9.1.2 and vehicle, special category and ro ro spaces in accordance with 20.6.1.3. This head does not apply to cargo pump rooms of chemical tankers carrying liquid cargoes referred to in regulation II-2/1.6.2 of the Convention, unless the Register specifically accepts the use of these systems based on additional tests with alcohol based fuel and alcohol resistant foam.

24.6.2 Definitions

24.6.2.1 *Design filling rate* is at least the minimum nominal filling rate used during the approval tests.

24.6.2.2 *Foam* is the extinguishing medium produced when foam solution passes through a foam generator and is mixed with air.

24.6.2.3 *Foam solution* is a solution of foam concentrate and water.

24.6.2.4 *Foam concentrate* is a liquid which, when mixed with water in the appropriate concentration forms a foam solution.

24.6.2.5 *Foam delivery ducts* are supply ducts for introducing high-expansion foam into the protected space from foam generators located outside the protected space.

24.6.2.6 *Foam mixing ratio* is the percentage of foam concentrate mixed with water forming the foam solution.

24.6.2.7 *Foam generators* are discharge devices or assemblies through which high expansion foam solution is aerated to form foam that is discharged into the protected space. Foam generators using inside air typically consist of a nozzle or set of nozzles and a casing. The casing is typically made of perforated steel/stainless steel plates shaped into a box that enclose the nozzle(s). Foam generators using outside air typically consist of nozzles enclosed within a casing that spray onto a screen. An electric, hydraulic or pneumatically driven fan is provided to aerate the solution.

24.6.2.8 *High-expansion foam fire-extinguishing systems* are fixed total flooding extinguishing systems that use either inside air or outside air for aeration of the foam solution. A high-expansion foam system consists of both the foam generators and the dedicated foam concentrate approved during the fire testing specified in 24.6.3.1.3.

24.6.2.9 *Inside air foam system* is a fixed high-expansion foam fire extinguishing system with foam genera-

tors located inside the protected space and drawing air from that space.

24.6.2.10 *Nominal flow rate* is the foam solution flow rate expressed in ℓ/min .

24.6.2.11 *Nominal application rate* is the nominal flow rate per area expressed in $\ell/\text{min}/\text{m}^2$.

24.6.2.12 *Nominal foam expansion ratio* is the ratio of the volume of foam to the volume of foam solution from which it was made, under non-fire conditions, and at an ambient temperature of e.g. around 20°C .

24.6.2.13 *Nominal foam production* is the volume of foam produced per time unit, i.e. nominal flow rate times nominal foam expansion ratio, expressed in m^3/min .

24.6.2.14 *Nominal filling rate* is the ratio of nominal foam production to the area, i.e. expressed in m/min .

24.6.2.15 *Nominal filling time* is the ratio of the height of the protected space to the nominal filling rate, i.e. expressed in minutes.

24.6.2.16 *Outside air foam system* is a fixed high-expansion foam system with foam generators installed outside the protected space that are directly supplied with fresh air.

24.6.3 Fixed high-expansion foam fire-extinguishing systems

24.6.3.1 Principal performance

24.6.3.1.1 The system shall be capable of manual release, and shall be designed to produce foam at the required application rate within one minute of release. Automatic release of the system shall not be permitted unless appropriate operational measures or interlocks are provided to prevent any local application systems required by 10.5.6 from interfering with the effectiveness of the system.

24.6.3.1.2 The foam concentrates shall be approved by the Register based on the guidelines developed by the IMO, see *Guidelines for the performance and testing criteria and surveys of high expansion foam concentrates for fixed fire extinguishing systems (MSC/Circ.670)*. Different foam concentrate types shall not be mixed in a high-expansion foam system.

24.6.3.1.3 The system shall be capable of fire extinction and manufactured and tested to the satisfaction of the Register based on the guidelines developed by the IMO, see *Guidelines for the approval of fixed high expansion foam systems (MSC.1/Circ.1384)*.

24.6.3.1.4 The system and its components shall be suitably designed to withstand ambient temperature changes, vibration, humidity, shock, clogging and corrosion normally encountered on ships. Piping, fittings and related components inside the protected spaces (except gaskets) shall be designed to withstand 925°C .

24.6.3.1.5 System piping, foam concentrate storage tanks, components and pipe fittings in contact with the foam concentrate shall be compatible with the foam concentrate and be constructed of corrosion resistant materials such as stainless steel, or equivalent. Other system piping and foam generators

shall be full galvanized steel or equivalent. Distribution pipework shall have self-draining capability.

24.6.3.1.6 Means for testing the operation of the system and assuring the required pressure and flow shall be provided by pressure gauges at both inlets (water and foam concentrate supply) and at the outlet of the foam proportioner. A test valve shall be installed on the distribution piping downstream of the foam proportioner, along with orifices which reflect the calculated pressure drop of the system. All sections of piping shall be provided with connections for flushing, draining and purging with air. All nozzles shall be able to be removed for inspection in order to prove clear of debris.

24.6.3.1.7 Means shall be provided for the crew to safely check the quantity of foam concentrate and take periodic control samples for foam quality.

24.6.3.1.8 Operating instructions for the system shall be displayed at each operating position.

24.6.3.1.9 Spare parts shall be provided based on the manufacturer's instruction.

24.6.3.1.10 If an internal combustion engine is used as a prime mover for the seawater pump for the system, the fuel oil tank to the prime mover shall contain sufficient fuel to enable the pump to run on full load for at least 3 h and sufficient reserves of fuel shall be available outside the machinery space of category A to enable the pump to be run on full load for an additional 15 h. If the fuel tank serves other internal combustion engines simultaneously, the total fuel tank capacity shall be adequate for all connected engines.

24.6.3.1.11 The arrangement of foam generators and piping in the protected space shall not interfere with access to the installed machinery for routine maintenance activities.

24.6.3.1.12 The system source of power supply, foam concentrate supply and means of controlling the system shall be readily accessible and simple to operate, and shall be arranged at positions outside the protected space not likely to be cut off by a fire in the protected space. All electrical components directly connected to the foam generators shall have at least an IP 54 rating.

24.6.3.1.13 The piping system shall be sized in accordance with a hydraulic calculation technique to ensure availability of flows and pressures required for correct performance of the system.

Where the Hazen-Williams method is used, the following values of the friction factor *C* for different pipe types which may be considered should apply:

| Pipe type | C |
|--------------------------------|-----|
| Black or galvanized mild steel | 100 |
| Copper or copper alloys | 150 |
| Stainless steel | 150 |

24.6.3.1.14 The arrangement of the protected spaces shall be such that they may be ventilated as the space is being filled with foam. Procedures shall be provided to ensure that upper level dampers, doors and other suitable openings are kept open in case of a fire. For inside air foam systems, spaces below 500 m³ need not comply with this requirement.

24.6.3.1.15 Onboard procedures shall be established to require personnel re-entering the protected space after a system discharge to wear breathing apparatus to protect them from

oxygen deficient air and products of combustion entrained in the foam blanket.

24.6.3.1.16 Installation plans and operating manuals shall be supplied to the ship and be readily available on board. A list or plan shall be displayed showing spaces covered and the location of the zone in respect of each section. Instructions for testing and maintenance shall be available on board.

24.6.3.1.17 All installation, operation and maintenance instructions/plans for the system shall be in the working language of the ship. If the working language of the ship is not English, French, nor Spanish, a translation into one of these languages shall be included.

24.6.3.1.18 The foam generator room shall be ventilated to protect against overpressure, and shall be heated to avoid the possibility of freezing.

24.6.3.1.19 The quantity of foam concentrate available shall be sufficient to produce a volume of foam equal to at least five times the volume of the largest protected space enclosed by steel bulkheads, at the nominal expansion ratio, or enough for 30 min of full operation for the largest protected space, whichever is greater.

24.6.3.1.20 Machinery spaces, cargo pump-rooms, vehicle spaces, ro-ro spaces and special category spaces shall be provided with audible and visual alarms within the protected space warning of the release of the system. The alarms shall operate for the length of time needed to evacuate the space, but in no case less than 20 s.

24.6.3.2 Inside air foam systems

24.6.3.2.1 Systems for the protection of machinery spaces and cargo pump-rooms

- .1 The system shall be supplied by both main and emergency sources of power. The emergency power supply shall be provided from outside the protected space.
- .2 Sufficient foam generating capacity shall be provided to ensure the minimum design filling rate for the system is met and in addition shall be adequate to completely fill the largest protected space within 10 min. See *MSC.1/Circ.1528*. See also *IACS UI SC262 Rev.1* (taking into account 24.1.1.1).
- .3 The arrangement of foam generators shall in general be designed based on the approval test results. A minimum of two generators shall be installed in every space containing combustion engines, boilers, purifiers, and similar equipment. Small workshops and similar spaces may be covered with only one foam generator.
- .4 Foam generators shall be uniformly distributed under the uppermost ceiling in the protected spaces including the engine casing. The number and location of foam generators shall be adequate to ensure all high risk areas are protected in all parts and at all levels of the spaces. Extra foam generators may be required in obstructed

locations. The foam generators shall be arranged with at least 1 m free space in front of the foam outlets, unless tested with less clearance. The generators shall be located behind main structures, and above and away from engines and boilers in positions where damage from an explosion is unlikely.

24.6.3.2.2 Systems for the protection of vehicle, ro-ro, special category and cargo spaces

- .1 The system shall be supplied by the ship's main power source. An emergency power supply is not required.
- .2 Sufficient foam-generating capacity shall be provided to ensure the minimum design filling rate for the system is met and in addition shall be adequate to completely fill the largest protected space within 10 min. However, for systems protecting vehicle and ro-ro spaces and special category spaces, with decks that are reasonably gas-tight and that have a deck height of 3 m or less, the filling rate shall be not less than two thirds of the design filling rate and in addition sufficient to fill the largest protected space within 10 min.
- .3 The system may be divided into sections, however, the capacity and design of the system shall be based on the protected space demanding the greatest volume of foam. Adjacent protected spaces need not be served simultaneously if the boundaries between the spaces are "A" class divisions.
- .4 The arrangement of foam generators shall in general be designed based on the approval test results. The number of generators may be different, but the minimum design filling rate determined during approval testing shall be provided by the system. A minimum of two generators shall be installed in every space. The foam generators shall be arranged to uniformly distribute foam in the protected spaces, and the layout shall take into consideration obstructions that can be expected when cargo is loaded on board. As a minimum, generators shall be located on every second deck, including movable decks. The horizontal spacing of the generators shall ensure rapid supply of foam to all parts of the protected space. This shall be established on the basis of full scale tests.
- .5 The foam generators shall be arranged with at least 1 m free space in front of the foam outlets, unless tested with less clearance.

24.6.3.3 Outside air foam systems

24.6.3.3.1 Systems for the protection of machinery spaces and cargo pump rooms

- .1 The system shall be supplied by both main and emergency sources of power. The emergency power supply shall be provided from outside the protected machinery space.
- .2 Sufficient foam generating capacity shall be provided to ensure the minimum design filling rate for the system is met and in addition shall be adequate to completely fill the largest protected space within 10 min. See *MSC.1/Circ.1528*. See also *IACS UI SC262 Rev.1*(taking into account 24.1.1.1).
- .3 The arrangement of foam delivery ducts shall in general be designed based on the approval test results. The number of ducts may be different, but the minimum design filling rate determined during approval testing shall be provided by the system. A minimum of two ducts shall be installed in every space containing combustion engines, boilers, purifiers, and similar equipment. Small workshops and similar spaces may be covered with only one duct.
- .4 Foam delivery ducts shall be uniformly distributed under the uppermost ceiling in the protected spaces including the engine casing. The number and location of ducts shall be adequate to ensure all high risk areas are protected in all parts and at all levels of the spaces. Extra ducts may be required in obstructed locations. The ducts shall be arranged with at least 1 m free space in front of the foam delivery ducts, unless tested with less clearance. The ducts shall be located behind main structures, and above and away from engines and boilers in positions where damage from an explosion is unlikely.
- .5 The arrangement of the foam delivery ducts shall be such that a fire in the protected space will not affect the foam generating equipment. If the foam generators are located adjacent to the protected space, foam delivery ducts shall be installed to allow at least 450 mm of separation between the generators and the protected space, and the separating divisions shall be class "A-60" rated. Foam delivery ducts shall be constructed of steel having a thickness of not less than 5 mm. In addition, stainless steel dampers (single or multi bladed) with a thickness of not less than 3 mm shall be installed at the openings in the boundary bulkheads or decks between the foam generators and the protected space. The dampers shall be automatically operated (electrically, pneumatically or hydraulically) by means

of remote control of the foam generator related to them, and arranged to remain closed until the foam generators begin operating.

- .6 The foam generators shall be located where an adequate fresh air supply can be arranged.

24.6.3.3.2 Systems for the protection of vehicle and ro-ro spaces and special category and cargo spaces

- .1 The system shall be supplied by the ship's main power source. An emergency power supply is not required.
- .2 Sufficient foam-generating capacity shall be provided to ensure the minimum design filling rate for the system is met and in addition shall be adequate to completely fill the largest protected space within 10 min. However, for systems protecting vehicle and ro-ro spaces and special category spaces, with decks that are reasonably gas-tight and that have a deck height of 3 m or less, the filling rate shall be not less than two thirds of the design filling rate and in addition sufficient to fill the largest protected space within 10 min.
- .3 The system may be divided into sections, however, the capacity and design of the system shall be based on the protected space demanding the greatest volume of foam. Adjacent protected spaces need not be served simultaneously if the boundaries between the spaces are "A" class divisions.
- .4 The arrangement of foam delivery ducts shall in general be designed based on the approval test results. The number of ducts may be different, but the minimum design filling rate determined during approval testing shall be provided by the system. A minimum of two ducts shall be installed in every space. The foam generators shall be arranged to uniformly distribute foam in the protected spaces, and the layout shall take into consideration obstructions that can be expected when cargo is loaded on board. As a minimum, ducts shall be led to every second deck, including movable decks. The horizontal spacing of the ducts shall ensure rapid supply of foam to all parts of the protected space. This shall be established on the basis of full scale tests.
- .5 The system shall be arranged with at least 1 m free space in front of the foam outlets, unless tested with less clearance.
- .6 The arrangement of the foam delivery ducts shall be such that a fire in the protected space will not affect the foam generating equipment. If the foam generators are located adjacent to the protected space, foam delivery ducts shall be installed to allow at least 450 mm of separation between the generators and the pro-

tected space, and the separating divisions shall be class "A-60" rated. Foam delivery ducts shall be constructed of steel having a thickness of not less than 5 mm. In addition, stainless steel dampers (single or multi bladed) with a thickness of not less than 3 mm shall be installed at the openings in the boundary bulkheads or decks between the foam generators and the protected space. The dampers shall be automatically operated (electrically, pneumatically or hydraulically) by means of remote control of the foam generator related to them, and arranged to remain closed until the foam generators begin operating.

- .7 The foam generators shall be located where an adequate fresh air supply can be arranged.

24.6.3.4 Installation testing requirements

24.6.3.4.1 After installation, the pipes, valves, fittings and assembled systems shall be tested to the satisfaction of the *Register*, including functional testing of the power and control systems, water pumps, foam pumps, valves, remote and local release stations and alarms. Flow at the required pressure shall be verified for the system using orifices fitted to the test line. In addition, all distribution piping shall be flushed with freshwater and blown through with air to ensure that the piping is free of obstructions.

24.6.3.4.2 Functional tests of all foam proportioners or other foam mixing devices shall be carried out to confirm that the mixing ratio tolerance is within +30 to -0% of the nominal mixing ratio defined by the system approval. For foam proportioners using foam concentrates of Newtonian type with kinematic viscosity equal to or less than 100 cSt at 0°C and density equal to or less than 1,100 kg/m³, this test can be performed with water instead of foam concentrate. Other arrangements shall be tested with the actual foam concentrate.

24.6.3.5 Systems using outside air with generators installed inside the protected space

Systems using outside air but with generators located inside the protected space and supplied by fresh air ducts may be accepted by the *Register* provided that these systems have been shown to have performance and reliability equivalent to systems defined in 3.3. For acceptance, the *Register* should consider the following minimum design features:

- .1 lower and upper acceptable air pressure and flow rate in supply ducts;
- .2 function and reliability of damper arrangements;
- .3 arrangements and distribution of air delivery ducts including foam outlets; and
- .4 separation of air delivery ducts from the protected space.

24.6.4 Fixed low-expansion foam fire-extinguishing systems

24.6.4.1 Quantity and foam concentrates

24.6.4.1.1 The foam concentrates of low-expansion foam fire-extinguishing systems shall be approved by the *Register* based on the guidelines adopted by IMO, see *Revised Guidelines for the performance and testing criteria and surveys of low expansion foam concentrates for fixed fire-extinguishing systems (MSC.1/Circ.1312 and MSC.1/Circ.1312/Corr.1)*. Different foam concentrate types shall not be mixed in a low expansion foam system. Foam concentrates of the same type from different manufacturers shall not be mixed unless they are approved for compatibility.

24.6.4.1.2 The system shall be capable of discharging through fixed discharge outlets, in no more than 5 min, a quantity of foam sufficient to produce an effective foam blanket over the largest single area over which oil fuel is liable to spread.

24.6.4.2 Installation requirements

24.6.4.2.1 Means shall be provided for effective distribution of the foam through a permanent system of piping and control valves or cocks to suitable discharge outlets, and for the foam to be effectively directed by fixed sprayers onto other main fire hazards in the protected space. The means for effective distribution of the foam shall be proven acceptable to the *Register* through calculation or by testing.

24.6.4.2.2 The means of control of any such systems shall be readily accessible and simple to operate and shall be grouped together in as few locations as possible at positions not likely to be cut off by a fire in the protected space.

24.6.5 Medium expansion foam concentrates onboard

For medium expansion foam concentrates onboard, tests as specified in MSC/Circ.798 shall be performed and carried out at laboratories acceptable to the *Register*. A record of the age of the foam concentrate and of subsequent controls shall be kept onboard.

24.6.6 Additional measures for cargoes ($\leq 60^{\circ}\text{C}$) for which a regular fixed deck foam system is not effective

For cargoes ($\leq 60^{\circ}\text{C}$) for which a regular fixed deck foam system complying with this Section is not effective (see MSC/Circ. 553) the following additional measures shall be required:

- .1 the foam shall be of an alcohol resistant type;
- .2 the capacity and application rates of the fixed deck foam system shall comply with requirements specified in *Rules for the classification of ships, Part 27 – Chemical Tankers*, 11.3, except that lower application rates may be accepted based on performance test;
- .3 foam concentrate quantity sufficient for 20 min of foam generation may be accepted for tankers fitted with inert gas system.

24.7 FIXED PRESSURE WATER-SPRAYING AND WATER-MIST FIRE-EXTINGUISHING SYSTEMS

24.7.1 Application

This head details the specifications for fixed pressure water-spraying and water-mist fire-extinguishing systems as required by Sections in this Part of the Rules for the classification of ships.

24.7.2 Engineering specifications

24.7.2.1 Fixed pressure water-spraying fire-extinguishing systems

Fixed-pressure water-spraying fire-extinguishing systems for machinery spaces and cargo pump-rooms shall be approved by the *Register* based on the guidelines developed by the IMO.

24.7.2.2 Equivalent water-mist fire-extinguishing systems

Water-mist fire-extinguishing systems for machinery spaces and cargo pump-rooms shall be approved by the *Register* based on the guidelines developed by the IMO, see *Revised guidelines for the approval of equivalent water-based fire-extinguishing systems for machinery spaces and cargo pump-rooms (MSC/Circ.1165)*. See also *IACS UI SC218, Rev.1 and IACS UI SC219, Rev.1* (taking into account 24.1.1.1).

24.7.2.3 Fixed pressure water-spraying fire-extinguishing systems for cabin balconies

Fixed pressure water-spraying fire-extinguishing systems for cabin balconies shall be approved by the *Register* based on the guidelines developed by the IMO.

24.7.2.4 Fixed water-based fire-fighting systems for ro-ro spaces, vehicle spaces and special category spaces

Fixed water-based fire-fighting systems for ro-ro spaces, vehicle spaces and special category spaces shall be approved by the *Register* based on guidelines developed by the IMO, see *Revised guidelines for approval of fixed water-based fire-fighting systems for ro-ro spaces and special category spaces (MSC.1/Circ.1430/Rev.3)*.

24.8 AUTOMATIC SPRINKLER, FIRE DETECTION AND FIRE ALARM SYSTEMS

24.8.1 Application

This head details the specifications for automatic sprinkler, fire detection and fire alarm systems as required by Sections in this Part of the Rules for the classification of ships.

24.8.2 Engineering specifications**24.8.2.1 General****24.8.2.1.1** Type of sprinkler systems

The automatic sprinkler systems shall be of the wet pipe type, but small exposed sections may be of the dry pipe type where, in the opinion of the *Register*, this is a necessary precaution. Control stations, where water may cause damage to essential equipment, may be fitted with a dry pipe system or a pre-action system as permitted by 10.6.1.1. Saunas shall be fitted with a dry pipe system, with sprinkler heads having an operating temperature up to 140°C. See *IACS UI SC130 Rev.2* (taking into account 24.1.1.1).

24.8.2.1.2 Sprinkler systems equivalent to those specified in 24.8.2.2 to 24.8.2.4.

Automatic sprinkler systems equivalent to those specified in 24.8.2.2 to 24.8.2.4 shall be approved by the *Register* based on the guidelines developed by the IMO, see *Revised guidelines for approval of sprinkler systems equivalent to that referred to in SOLAS regulation II-2/12, resolution A.800(19), as amended by resolutions MSC.265(84) and MSC.284(86)*.

24.8.2.2 Sources of power supply**24.8.2.2.1** Passenger ships

There shall be not less than two sources of power supply for the seawater pump and automatic alarm and detection system. Where the sources of power for the pump are electrical, these shall be a main generator and an emergency source of power. One supply for the pump shall be taken from the main switchboard, and one from the emergency switchboard by separate feeders reserved solely for that purpose. The feeders shall be so arranged as to avoid galleys, machinery spaces and other enclosed spaces of high fire risk except in so far as it is necessary to reach the appropriate switchboards, and shall be run to an automatic changeover switch situated near the sprinkler pump. This switch shall permit the supply of power from the main switchboard so long as a supply is available therefrom, and be so designed that upon failure of that supply it will automatically change over to the supply from the emergency switchboard. The switches on the main switchboard and the emergency switchboard shall be clearly labelled and normally kept closed. No other switch shall be permitted in the feeders concerned. One of the sources of power supply for the alarm and detection system shall be an emergency source. Where one of the sources of power for the pump is an internal combustion engine it shall, in addition to complying with the provisions of 24.8.2.4.3, be so situated that a fire in any protected space will not affect the air supply to the machinery.

24.8.2.2.2 Cargo ships

There shall not be less than two sources of power supply for the seawater pump and automatic alarm and detection system. If the pump is electrically driven, it shall be connected to the main source of electrical power, which shall be capable of being supplied by at least two generators. The feeders shall be so arranged as to avoid galleys, machinery spaces and other enclosed spaces of high fire risk except in so

far as it is necessary to reach the appropriate switchboards. One of the sources of power supply for the alarm and detection system shall be an emergency source. Where one of the sources of power for the pump is an internal combustion engine, it shall, in addition to complying with the provisions of 24.8.2.4.3, be so situated that a fire in any protected space will not affect the air supply to the machinery.

24.8.2.3 Component requirements**24.8.2.3.1** Sprinklers

- .1 The sprinklers shall be resistant to corrosion by the marine atmosphere. In accommodation and service spaces the sprinklers shall come into operation within the temperature range from 68°C to 79°C, except that in locations such as drying rooms, where high ambient temperatures might be expected, the operating temperature may be increased by not more than 30°C above the maximum deckhead temperature.
- .2 A quantity of spare sprinkler heads shall be provided for all types and ratings installed on the ship as follows:

| Total number of heads | Required number of spares |
|-----------------------|---------------------------|
| < 300 | 6 |
| 300 to 1000 | 12 |
| > 1000 | 24 |

The number of spare sprinkler heads of any type need not exceed the total number of heads installed of that type

24.8.2.3.2 Pressure tanks

- .1 A pressure tank having a volume equal to at least twice that of the charge of water specified in this paragraph shall be provided. The tank shall contain a standing charge of fresh water, equivalent to the amount of water which would be discharged in 1 min by the pump referred to in 24.8.2.3.3.2, and the arrangements shall provide for maintaining an air pressure in the tank such as to ensure that where the standing charge of fresh water in the tank has been used the pressure will be not less than the working pressure of the sprinkler, plus the pressure exerted by a head of water measured from the bottom of the tank to the highest sprinkler in the system. Suitable means of replenishing the air under pressure and of replenishing the fresh water charge in the tank shall be provided. A glass gauge shall be provided to indicate the correct level of the water in the tank.
- .2 Means shall be provided to prevent the passage of seawater into the tank.

24.8.2.3.3 Sprinkler pumps

- .1 An independent power pump shall be provided solely for the purpose of continuing automatically the discharge of water from the sprinklers. The pump shall be brought into action automatically by the pressure drop in the system before the standing fresh water charge in the pressure tank is completely exhausted.
- .2 The pump and the piping system shall be capable of maintaining the necessary pressure at the level of the highest sprinkler to ensure a continuous output of water sufficient for the simultaneous coverage of a minimum area of 280 m² at the application rate specified in 24.8.2.5.2.3. The hydraulic capability of the system shall be confirmed by the review of hydraulic calculations, followed by a test of the system, if deemed necessary by the *Register*.
- .3 The pump shall have fitted on the delivery side a test valve with a short open-ended discharge pipe. The effective area through the valve and pipe shall be adequate to permit the release of the required pump output while maintaining the pressure in the system specified in 24.8.2.3.2.1.

24.8.2.4 Installation requirements

24.8.2.4.1 General

- .1 Any parts of the system which may be subjected to freezing temperatures in service shall be suitably protected against freezing.
- .2 Special attention shall be paid to the specification of water quality provided by the system manufacturer to prevent internal corrosion of sprinklers and clogging or blockage arising from products of corrosion or scale-forming minerals.

24.8.2.4.2 Piping arrangements

- .1 Sprinklers shall be grouped into separate sections, each of which shall contain no more than 200 sprinklers. In passenger ships, any section of sprinklers shall not serve more than two decks and shall not be situated in more than one main vertical zone. However, the *Register* may permit such a section of sprinklers to serve more than two decks or be situated in more than one main vertical zone, if it is satisfied that the protection of the ship against fire will not thereby be reduced.
- .2 Each section of sprinklers shall be capable of being isolated by one stop-valve only. The stop-valve in each section shall be readily accessible in a location outside of the associated section or in cabinets within stairway enclosures. The valve's location shall be clearly and permanently

indicated. Means shall be provided to prevent the operation of the stop-valves by any unauthorized person.

- .3 A test valve shall be provided for testing the automatic alarm for each section of sprinklers by a discharge of water equivalent to the operation of one sprinkler. The test valve for each section shall be situated near the stop-valve for that section.
- .4 The sprinkler system shall have a connection from the ship's fire main by way of a lockable screw-down non-return valve at the connection which will prevent a back-flow from the sprinkler system to the fire main.
- .5 A gauge indicating the pressure in the system shall be provided at each section stop-valve and at a central station.
- .6 The sea inlet to the pump shall wherever possible be in the space containing the pump and shall be so arranged that when the ship is afloat it will not be necessary to shut off the supply of seawater to the pump for any purpose other than the inspection or repair of the pump.

24.8.2.4.3 Location of systems

The sprinkler pump and tank shall be situated in a position reasonably remote from any machinery space of category A and shall not be situated in any space required to be protected by the sprinkler system.

24.8.2.5 System control requirements

24.8.2.5.1 Ready availability

- .1 Any required automatic sprinkler, fire detection and fire alarm system shall be capable of immediate operation at all times and no action by the crew shall be necessary to set it in operation.
- .2 The automatic sprinkler system shall be kept charged at the necessary pressure and shall have provision for a continuous supply of water as required in this Section.

24.8.2.5.2 Alarm and indication

- .1 Each section of sprinklers shall include means for giving a visual and audible alarm signal automatically at one or more indicating units whenever any sprinkler comes into operation. Such alarm systems shall be such as to indicate if any fault occurs in the system. Such units shall indicate in which section served by the system a fire has occurred and shall be centralized on the navigation bridge or in the continuously-manned central control station and, in addition, visible and audible alarms from the unit shall also be placed in a position other than on the aforementioned spaces to ensure that the indication

of fire is immediately received by the crew.

- .2 Switches shall be provided at one of the indicating positions referred to in 24.8.2.5.2.1 which will enable the alarm and the indicators for each section of sprinklers to be tested.
- .3 Sprinklers shall be placed in an overhead position and spaced in a suitable pattern to maintain an average application rate of not less than 5 l/m²/min over the nominal area covered by the sprinklers. For this purpose, nominal area shall be taken as the gross horizontal projection of the area to be covered. However, the *Register* may permit the use of sprinklers providing such an alternative amount of water suitably distributed as has been shown to the satisfaction of the *Register* to be not less effective.
- .4 A list or plan shall be displayed at each indicating unit showing the spaces covered and the location of the zone in respect of each section. Suitable instructions for testing and maintenance shall be available.

24.8.2.5.3 Testing

Means shall be provided for testing the automatic operation of the pump on reduction of pressure in the system.

24.8.3 See *MSC.1/Circ.1556*.

24.9 FIXED FIRE DETECTION AND FIRE ALARM SYSTEMS

24.9.1 Application

24.9.1.1 This head details the specifications of fixed fire detection and fire alarm systems as required by Sections in this Part of the Rules for the classification of ships.

For additional requirements for fire detecting system for unattended machinery spaces see 24.9.3.

Installation of atmospheric oil mist detectors in machinery spaces, where provided, shall comply with *Code of Practice for Oil Mist Detectors* (see *MSC/Circ. 1086*).

24.9.1.2 Definitions

24.9.1.2.1 *Section* means a group of fire detectors and manually operated call points as reported in the indicating unit(s).

24.9.1.2.2 *Section identification capability* means a system with the capability of identifying the section in which a detector or manually operated call point has activated.

24.9.1.2.3 *Individually identifiable* means a system with the capability to identify the exact location and type of detector or manually activated call point

which has activated, and which can differentiate the signal of that device from all others.

24.9.2 Engineering specifications

24.9.2.1 General requirements

24.9.2.1.1 Any required fixed fire detection and fire alarm system with manually operated call points shall be capable of immediate operation at all times (this does not require a backup control panel). Notwithstanding this, particular spaces may be disconnected, for example, workshops during hot work and ro-ro spaces during on and off-loading. The means for disconnecting, the detectors shall be designed to automatically restore the system to normal surveillance after a predetermined time that is appropriate for the operation in question. The space shall be manned or provided with a fire patrol when detectors required by the regulation are disconnected. Detectors in all other spaces shall remain operational.

24.9.2.1.2 The fire detection system shall be designed to (see *IACS UI SC147 Rev.2*, taking into account 24.1.1.1):

- .1 control and monitor input signals from all connected fire and smoke detectors and manual call points;
- .2 provide output signals to the navigation bridge, continuously manned central control station or onboard safety centre to notify the crew of fire and fault conditions;
- .3 monitor power supplies and circuits necessary for the operation of the system for loss of power and fault conditions; and
- .4 the system may be arranged with output signals to other fire safety systems including:
 - (1) paging systems, fire alarm or public address systems;
 - (2) fan stops;
 - (3) fire doors;
 - (4) fire dampers;
 - (5) sprinkler systems;
 - (6) smoke extraction systems;
 - (7) low-location lighting systems;
 - (8) fixed local application fire-extinguishing systems;
 - (9) closed circuit television (CCTV) systems; and
 - (10) other fire safety systems.

24.9.2.1.3 The fire detection system may be connected to a decision management system provided that:

- .1 the decision management system is proven to be compatible with the fire detection system;
- .2 the decision management system can be disconnected without losing any of the functions required by this head for the fire detection system; and
- .3 malfunction of the interfaced and connected equipment should not propagate under any circumstance to the fire detection system.

24.9.2.1.4 Detectors and manual call points shall be connected to dedicated sections of the fire detection system. Oth-

er fire safety functions, such as alarm signals from the sprinkler valves, may be permitted if in separate sections.

24.9.2.1.5 The system and equipment shall be suitably designed to withstand supply voltage variation and transients, ambient temperature changes, vibration, humidity, shock, impact and corrosion normally encountered in ships. All electrical and electronic equipment on the bridge or in the vicinity of the bridge shall be tested for electromagnetic compatibility, taking into account the recommendations developed by the IMO, see *General requirements for electromagnetic compatibility for all electrical and electronic equipment, resolution A.813(19)*.

24.9.2.1.6 Fixed fire detection and fire alarm systems with individually identifiable fire detectors shall be so arranged that:

- .1 means are provided to ensure that any fault (e.g., power break, short circuit, earth, etc.) occurring in the section will not prevent the continued individual identification of the remainder of the connected detectors in the section;
- .2 all arrangements are made to enable the initial configuration of the system to be restored in the event of failure (e.g., electrical, electronic, informatics, etc.);
- .3 the first initiated fire alarm will not prevent any other detector from initiating further fire alarms; and
- .4 no section will pass through a space twice. When this is not practical (e.g., for large public spaces), the part of the section which by necessity passes through the space for a second time shall be installed at the maximum possible distance from the other parts of the section.

24.9.2.1.7 In passenger ships, the fixed fire detection and fire alarm system shall be capable of remotely and individually identifying each detector and manually operated call point. Fire detectors fitted in passenger ship cabins, when activated, shall also be capable of emitting, or cause to be emitted, an audible alarm within the space where they are located. In cargo ships and on passenger ship cabin balconies the fixed fire detection and fire alarm system shall, as a minimum, have section identification capability.

24.9.2.1.8 In cargo ships and on passenger ship cabin balconies, where an individually identifiable system is fitted, notwithstanding the provisions in 24.9.2.1.6.1, isolator modules need not be provided at each fire detector if the system is arranged in such a way that the number and location of individually identifiable fire detectors rendered ineffective due to a fault would not be larger than an equivalent section in a section identifiable system, arranged in accordance with 24.9.2.4.1.

24.9.2.2 Sources of power supply

24.9.2.2.1 There shall be not less than two sources of power supply for the electrical equipment used in the operation of the fixed fire detection and fire alarm system, one of which shall be an emergency source of power. The supply shall be provided by separate feeders reserved solely for that purpose. Such feeders shall run to an automatic changeover

switch situated in or adjacent to the control panel for the fire detection system. The changeover switch shall be arranged such that a fault will not result in the loss of both power supplies. The main (respective emergency) feeder shall run from the main (respective emergency) switchboard to the changeover switch without passing through any other distributing switchboard.

24.9.2.2.2 The operation of the automatic changeover switch or a failure of one of the power supplies shall not result in loss of fire detection capability. Where a momentary loss of power would cause degradation of the system, a battery of adequate capacity shall be provided to ensure continuous operation during changeover.

24.9.2.2.3 There shall be sufficient power to permit the continued operation of the system with all detectors activated, but not more than 100 if the total exceeds this figure.

24.9.2.2.4 The emergency source of power specified in 24.9.2.2.1 above may be supplied by accumulator batteries or from the emergency switchboard. The power source shall be sufficient to maintain the operation of the fire detection and fire alarm system for the periods required under *Rules for the classification of ships, Part 12 - Electrical Equipment*, 19.1 or 9.3 (as applicable) and, at the end of that period, shall be capable of operating all connected visual and audible fire alarm signals for a period of at least 30 min. See *MSC.1/Circ.1554*.

24.9.2.2.5 Where the system is supplied from accumulator batteries, they shall be located in or adjacent to the control panel for the fire detection system, or in another location suitable for use in an emergency. The rating of the battery charge unit shall be sufficient to maintain the normal output power supply to the fire detection system while recharging the batteries from a fully discharged condition.

24.9.2.3 Component requirements

24.9.2.3.1 Detectors

- .1 Detectors shall be operated by heat, smoke or other products of combustion, flame, or any combination of these factors. Detectors operated by other factors indicative of incipient fires may be considered by the *Register* provided that they are no less sensitive than such detectors.
- .2 Smoke detectors required in all stairways, corridors and escape routes within accommodation spaces shall be certified to operate before the smoke density exceeds 12.5% obscuration per metre, but not until the smoke density exceeds 2% obscuration per metre, when tested according to standards EN 54:2001 and IEC 60092-504. Alternative testing standards may be used as determined by the *Register*. Smoke detectors to be installed in other spaces shall operate within sensitivity limits to the satisfaction of the *Register* having regard to the avoidance of detector insensitivity or oversensitivity.
- .3 Heat detectors shall be certified to operate before the temperature exceeds 78°C but not until the temperature exceeds 54°C,

when the temperature is raised to those limits at a rate less than 1°C per min, when tested according to standards EN 54:2001 and IEC 60092-504. Alternative testing standards may be used as determined by the *Register*. At higher rates of temperature rise, the heat detector shall operate within temperature limits to the satisfaction of the *Register* having regard to the avoidance of detector insensitivity or oversensitivity.

- .4 The operation temperature of heat detectors in drying rooms and similar spaces of a normal high ambient temperature may be up to 130°C, and up to 140°C in saunas.
- .5 Flame detectors shall be tested according to standards EN 54-10:2001 and IEC 60092-504. Alternative testing standards may be used as determined by the *Register*.
- .6 All detectors shall be of a type such that they can be tested for correct operation and restored to normal surveillance without the renewal of any component.
- .7 Fixed fire detection and fire alarm systems for cabin balconies shall be approved by the *Register*, based on the guidelines developed by the IMO, see *Guidelines for approval of fixed fire detection and fire alarm systems for cabin balconies*(MSC.1/Circ.1242).
- .8 Detectors fitted in hazardous areas shall be tested and approved for such service. Detectors required by 20.4 and installed in spaces that comply with 20.3.2.2 need not be suitable for hazardous areas. Detectors fitted in spaces carrying dangerous goods, required by Section 19, table 19.3, to comply with 19.3.2, shall be suitable for hazardous areas.

24.9.2.3.2 Control panel

The control panel for the fire detection system shall be tested according to standards EN 54-2:1997, EN 54-4:1997 and IEC 60092-504:2001. Alternative standards may be used as determined by the *Register*.

24.9.2.3.3 Cables

Cables used in the electrical circuits shall be flame retardant according to standard IEC 60332-1. On passenger ships, cables routed through other main vertical zones that they serve, and cables to control panels in an unattended fire control station shall be fire resisting according to standard IEC 60331, unless duplicated and well separated.

24.9.2.4 Installation requirements

24.9.2.4.1 Sections

- .1 Detectors and manually operated call points shall be grouped into sections.
- .2 A section of fire detectors which covers a control station, a service space or an accommodation space shall not include a machinery space of category A or a ro-ro space. A section of fire detectors which covers a ro-ro space shall not include a machinery space of category A. For fixed fire detection systems with remotely and individually identifiable fire detectors, a section covering fire detectors in accommodation, service spaces and control stations shall not include fire detectors in machinery spaces of category A or ro-ro spaces.
- .3 Where the fixed fire detection and fire alarm system does not include means of remotely identifying each detector individually, no section covering more than one deck within accommodation spaces, service spaces and control stations shall normally be permitted except a section which covers an enclosed stairway. In order to avoid delay in identifying the source of fire, the number of enclosed spaces included in each section shall be limited as determined by the *Register*. If the detection system is fitted with remotely and individually identifiable fire detectors, the sections may cover several decks and serve any number of enclosed spaces.
- .4 In passenger ships, a section of detectors and manually operated call points shall not be situated in more than one main vertical zone, except on cabin balconies.

24.9.2.4.2 Position of detectors

- .1 Detectors shall be located for optimum performance. Positions near beams and ventilation ducts, or other positions where patterns of air flow could adversely affect performance, and positions where impact or physical damage is likely, shall be avoided. Detectors shall be located on the overhead at a minimum distance of 0.5 m away from bulkheads, except in corridors, lockers and stairways.
- .2 The maximum spacing of detectors shall be in accordance with the table below:

| Type of detector | Maximum floor area per detector | Maximum distance apart between centres | Maximum distance away from bulkheads |
|------------------|---------------------------------|--|--------------------------------------|
| Heat | 37 m ² | 9 m | 4.5 m |
| Smoke | 74 m ² | 11 m | 5.5 m |

The *Register* may require or permit other spacing based upon test data which demonstrate the characteristics of the detectors. Detectors located below moveable ro-ro decks shall be in accordance with the above.

- .3 Detectors in stairways shall be located at least at the top level of the stair and at every second level beneath.
- .4 When fire detectors are installed in freezers, drying rooms, saunas, parts of galleys used to heat food, laundries and other spaces where steam and fumes are produced, heat detectors may be used.
- .5 Where a fixed fire detection and fire alarm system is required by 7.5, spaces having little or no fire risk need not be fitted with detectors. Such spaces include void spaces with no storage of combustibles, private bathrooms, public toilets, fire-extinguishing medium storage rooms, cleaning gear lockers (in which flammable liquids are not stowed), open deck spaces and enclosed promenades having little or no fire risk and that are naturally ventilated by permanent openings.

24.9.2.4.3 Arrangement of cables

- .1 Cables which form part of the system shall be so arranged as to avoid galleys, machinery spaces of category A, and other enclosed spaces of high fire risk except where it is necessary to provide for fire detection or fire alarms in such spaces or to connect to the appropriate power supply.
- .2 A section with individually identifiable capability shall be arranged so that it cannot be damaged at more than one point by a fire.

24.9.2.5 System control requirements

24.9.2.5.1 Visual and audible fire signals

See Code on Alerts and Indicators, 2009, as adopted by IMO by resolution A.1021(26).

- .1 The activation of any detector or manually operated call point shall initiate a visual and audible fire detection alarm signal at the control panel and indicating units. If the signals have not been acknowledged within 2 min, an audible fire alarm shall be automatically sounded throughout the crew accommodation and service spaces, control stations and machinery spaces of category A. This alarm sounder system need not be an integral part of the detection system. See *IACS UI SC35 Rev.3* (taking into account 24.1.1.1). See also *MSC.1/Circ.1487*.

- .2 In passenger ships, the control panel shall be located in the onboard safety centre. In cargo ships, the control panel shall be located on the navigation bridge or in the fire control station.
- .3 In passenger ships, an indicating unit that is capable of individually identifying each detector that has been activated or manually operated call point that has operated shall be located on the navigation bridge. In cargo ships, an indicating unit shall be located on the navigation bridge if the control panel is located in the fire control room. In ships with a cargo control room, an additional indicating unit shall be located in the cargo control room. In cargo ships and on passenger cabin balconies, indicating units shall, as a minimum, denote the section in which a detector has activated or manually operated call point has operated. See *MSC.1/Circ.1528*. See also *IACS UI SC271*.
- .4 Clear information shall be displayed on or adjacent to each indicating unit about the spaces covered and the location of the sections.
- .5 Power supplies and electric circuits necessary for the operation of the system shall be monitored for loss of power and fault conditions as appropriate including:
 - (1) a single open or power break fault caused by a broken wire;
 - (2) a single ground fault caused by the contact of a wiring conductor to a metal component; and
 - (3) a single wire to wire fault caused by the contact of two or more wiring conductors.

Occurrence of a fault condition shall initiate a visual and audible fault signal at the control panel which shall be distinct from a fire signal.
- .6 Means to manually acknowledge all alarm and fault signals shall be provided at the control panel. The audible alarm sounders on the control panel and indicating units may be manually silenced. The control panel shall clearly distinguish between normal, alarm, acknowledged alarm, fault and silenced conditions.
- .7 The system shall be arranged to automatically reset to the normal operating condition after alarm and fault conditions are cleared.
- .8 When the system is required to sound a local audible alarm within the cabins where the detectors are located, a means to silence the local audible alarms from the control panel shall not be permitted.
- .9 In general, audible alarm sound pressure levels at the sleeping positions in the cabins and 1 m from the source shall be at least 75 dB(A) and at least 10 dB(A)

above ambient noise levels existing during normal equipment operation with the ship under way in moderate weather. The sound pressure level should be in the 1/3 octave band with respect to the fundamental frequency. Audible alarm signals shall not exceed 120 dB(A).

24.9.2.5.2 Testing

Suitable instructions and component spares for testing and maintenance shall be provided. Detectors shall be periodically tested using equipment suitable for the types of fires to which the detector is designed to respond. Detectors installed within cold spaces such as refrigerated compartments shall be tested using procedures having due regard for such locations, see *recommendations of the International Electrotechnical Commission, in particular publication IEC 60068-2-1 – Section one – Test Ab, Environmental Testing – Part 2-1: Tests – Test A: Cold*. Ships with self-diagnostic systems that have in place a cleaning regime for areas where heads may be prone to contamination may carry out testing in accordance with the requirements of the *Register*.

24.9.3 Fire detecting system for unattended machinery spaces (IACS UR F32)

24.9.3.1 An automatic fire detection system is to be fitted in the machinery spaces.

24.9.3.2 The system is to be designed with self-monitoring properties. Power or system failures are to initiate an audible alarm distinguishable from the fire alarm.

24.9.3.3 The fire detection indicating panel is to be located on the navigating bridge, fire control station, or other accessible place where a fire in the machinery space will not render it inoperative.

24.9.3.4 The fire detection indicating panel is to indicate the place of the detected fire in accordance with the arranged fire zones by means of a visual signal. Audible signals clearly distinguishable in character from any other audible signals shall be audible throughout the navigating bridge and the accommodation area of the personnel responsible for the operation of the machinery space.

24.9.3.5 Fire detectors are to be of types, and so located, that they will rapidly detect the onset of fire in conditions normally present in the machinery space. Consideration is to be given to avoiding false alarms. The type and location of detectors are to be approved by the *Register* and a combination of detector types is recommended in order to enable the system to react to more than one type of fire symptom.

24.9.3.6 Fire detector zones are to be arranged in a manner that will enable the operating staff to locate the seat of the fire. The arrangement and the number of loops and the location of detector heads is to be approved in each case. Air currents created by the machinery are not to render the detection system ineffective.

24.9.3.7 When fire detectors are provided with the means to adjust their sensitivity, necessary arrangements are to be ensured to fix and identify the set point.

24.9.3.8 When it is intended that a particular loop or detector is to be temporarily switched off, this state is to be clearly indicated. Reactivation of the loop or detector is to be performed automatically after a present time.

24.9.3.9 The fire detection indicating panel is to be provided with facilities for functional testing.

24.9.3.10 The fire detecting system shall be fed automatically from the emergency source of power by a separate feeder if the main source of power fails.

24.9.3.11 Facilities are to be provided in the fire detecting system to release manually the fire alarm from the following places:

Passageways having entrances to engine and boiler rooms, navigating bridge, control station in engine room.

24.9.3.12 The testing of the fire detecting system on board is to be carried out to the satisfaction of the *Register*.

24.9.3.13 Requirements on indication of the operation of each individual detecting head are left to the discretion of the *Register*.

24.10 SAMPLE EXTRACTION SMOKE DETECTION SYSTEMS

24.10.1 Application

This head details the specifications for sample extraction smoke detection systems in cargo spaces as required by Sections in this Part of the Rules for the classification of ships.

24.10.2 Engineering specifications

24.10.2.1 General requirements

24.10.2.1.1 Wherever in the text of this Section the word “system” appears, it shall mean “sample extraction smoke detection system”.

- .1 A sample extraction smoke detection system consists of the following main components:
 - .1 smoke accumulators: air collection devices installed at the open ends of the sampling pipes in each cargo hold that perform the physical function of collecting air samples for transmission to the control panel through the sampling pipes, and may also act as discharge nozzles for the fixed-gas fire-extinguishing system, if installed;
 - .2 sampling pipes: a piping network that connects the smoke accumulators to the control panel, arranged in sections to allow the location of the fire to be readily identified;
 - .3 three-way valves: if the system is interconnected to a fixed-gas fire-

- extinguishing system, three-way valves are used to normally align the sampling pipes to the control panel and, if a fire is detected, the three-way valves are re-aligned to connect the sampling pipes to the fire-extinguishing system discharge manifold and isolate the control panel; and
- .4 control panel: the main element of the system which provides continuous monitoring of the protected spaces for indication of smoke. It typically may include a viewing chamber or smoke sensing units. Extracted air from the protected spaces is drawn through the smoke accumulators and sampling pipes to the viewing chamber, and then to the smoke sensing chamber where the airstream is monitored by electrical smoke detectors. If smoke is sensed, the repeater panel (normally on the bridge) automatically sounds an alarm (not localized). The crew can then determine, at the smoke sensing unit, which cargo hold is on fire and operate the pertinent three-way valve for discharge of the extinguishing agent.

24.10.2.1.2 Any required system shall be capable of continuous operation at all times except that systems operating on a sequential scanning principle may be accepted, provided that the interval between scanning the same position twice gives a maximum allowable interval determined as follows:

The interval (I) should depend on the number of scanning points (N) and the response time of the fans (T), with a 20% allowance: $I = 1.2 \times T \times N$

However, the maximum allowable interval should not exceed 120 s ($I_{max} = 120$ s).

24.10.2.1.3 The system shall be designed, constructed and installed so as to prevent the leakage of any toxic or flammable substances or fire-extinguishing media into any accommodation space, service space, control station or machinery space.

24.10.2.1.4 The system and equipment shall be suitably designed to withstand supply voltage variations and transients, ambient temperature changes, vibration, humidity, shock, impact and corrosion normally encountered in ships and to avoid the possibility of ignition of a flammable gas-air mixture.

24.10.2.1.5 The system shall be of a type that can be tested for correct operation and restored to normal surveillance without the renewal of any component.

24.10.2.1.6 An alternative power supply for the electrical equipment used in the operation of the system shall be provided.

24.10.2.2 Component requirements

24.10.2.2.1 The sensing unit shall be certified to operate before the smoke density within the sensing chamber exceeds 6.65% obscuration per metre.

24.10.2.2.2 Duplicate sample extraction fans shall be provided. The fans shall be of sufficient capacity to operate with the normal conditions or ventilation in the protected area and the connected pipe size shall be determined with consideration of fan suction capacity and piping arrangement to satisfy the conditions of 24.10.2.4.2.2. Sampling pipes shall be a minimum of 12 mm internal diameter. The fan suction capacity should be adequate to ensure the response of the most remote area within the required time criteria in 24.10.2.4.2.2. Means to monitor airflow shall be provided in each sampling line.

24.10.2.2.3 The control panel shall permit observation of smoke in the individual sampling pipes.

24.10.2.2.4 The sampling pipes shall be designed so as to ensure that, as far as practicable, equal quantities of airflow are extracted from each interconnected accumulator.

24.10.2.2.5 Sampling pipes shall be provided with an arrangement for periodically purging with compressed air.

24.10.2.2.6 The control panel for the smoke detection system shall be tested according to standards EN 54-2:1997, EN 54-4:1997 and IEC 60092-504:2001. Alternative standards may be used as determined by the *Register*.

24.10.2.3 Installation requirements

24.10.2.3.1 Smoke accumulators

- .1 At least one smoke accumulator shall be located in every enclosed space for which smoke detection is required. However, where a space is designed to carry oil or refrigerated cargo alternatively with cargoes for which a smoke sampling system is required, means may be provided to isolate the smoke accumulators in such compartments for the system. Such means shall be to the satisfaction of the *Register*.
- .2 Smoke accumulators shall be located on the overhead or as high as possible in the protected space, and shall be spaced so that no part of the overhead deck area is more than 12 m, measured horizontally, from an accumulator. Where systems are used in spaces which may be mechanically ventilated, the position of the smoke accumulators shall be considered having regard to the effects of ventilation. At least one additional smoke accumulator is to be provided in the upper part of each exhaust ventilation duct. An adequate filtering system shall be fitted at the additional accumulator to avoid dust contamination.
- .3 Smoke accumulators shall be positioned where impact or physical damage is unlikely to occur.

- .4 Sampling pipe networks shall be balanced to ensure compliance with 24.10.2.2.4. The number of accumulators connected to each sampling pipe shall ensure compliance with 24.10.2.4.2.2.
- .5 Smoke accumulators from more than one enclosed space shall not be connected to the same sampling pipe.
- .6 In cargo holds where non-gastight "tween-deck panels" (movable stowage platforms) are provided, smoke accumulators shall be located in both the upper and lower parts of the holds.

24.10.2.3.2 Sampling pipes

- .1 The sampling pipe arrangements shall be such that the location of the fire can be readily identified.
- .2 Sampling pipes shall be self-draining and suitably protected from impact or damage from cargo working.

24.10.2.4 System control requirements

24.10.2.4.1 Visual and audible fire signals

- .1 The detection of smoke or other products of combustion shall initiate a visual and audible signal at the control panel and indicating units.
- .2 The control panel shall be located on the navigation bridge or in the fire control station. An indicating unit shall be located on the navigation bridge if the control panel is located in the fire control station. See *IACS UI SC260 Rev.1* (taking into account 24.1.1.1). See also *MSC.1/Circ.1487*.
- .3 Clear information shall be displayed on or adjacent to the control panel and indicating units designating the spaces covered.
- .4 Power supplies necessary for the operation of the system shall be monitored for loss of power. Any loss of power shall initiate a visual and audible signal at the control panel and the navigating bridge which shall be distinct from a signal indicating smoke detection.
- .5 Means to manually acknowledge all alarm and fault signals shall be provided at the control panel. The audible alarm sounders on the control panel and indicating units may be manually silenced. The control panel shall clearly distinguish between normal, alarm, acknowledged alarm, fault and silenced conditions.
- .6 The system shall be arranged to automatically reset to the normal operating condition after alarm and fault conditions are cleared.

24.10.2.4.2 Testing

- .1 Suitable instructions and component spares shall be provided for the testing and maintenance of the system.

- .2 After installation, the system shall be functionally tested using smoke generating machines or equivalent as a smoke source. An alarm shall be received at the control unit in not more than 180 s for vehicle decks, and not more than 300 s for container and general cargo holds, after smoke is introduced at the most remote accumulator.

24.11 LOW-LOCATION LIGHTING SYSTEMS

24.11.1 Application

This head details the specifications for low-location lighting systems as required by Sections in this Part of the Rules for the classification of ships.

24.11.2 Engineering specifications

24.11.2.1 General requirements

Any required low-location lighting systems shall be approved by the Register based on the guidelines developed by the IMO, see Guidelines for the evaluation, testing and application of low-location lighting on passenger ships, as adopted by the IMO by resolution A.752(18) and the Interim Guidelines for the testing, approval and maintenance of evacuation guidance systems used as an alternative to low location lighting systems (MSC/Circ.1168) or an international standard acceptable to the Register, see recommendations by the International Organization for Standardization, in particular, publication ISO 15370:2001 on low-location lighting on passenger ships.

24.12 FIXED EMERGENCY FIRE PUMPS

24.12.1 Application

This head details the specifications for emergency fire pumps as required by Sections in this Part of the Rules for the classification of ships. This head is not applicable to passenger ships of 1,000 gross tonnage and upwards. See 10.2.2.3.1.1 for requirements for such ships.

24.12.2 Engineering specifications

24.12.2.1 General

The emergency fire pump shall be of a fixed independently driven power-operated pump. See *MSC.1/Circ.1388*.

24.12.2.2 Component requirements

24.12.2.2.1 Emergency fire pumps

See *IACS UI SC163 Rev.2* (taking into account 24.1.1.1).

- .1 Capacity of the pump
The capacity of the pump shall be sufficient for the simultaneous operation of at

least two fire hose nozzles coupled to any adjacent hydrants, at the pressure specified in .2, and shall not be less than 40% of the total capacity of the fire pumps required by 10.2.2.4.1, and in any case not less than the following:

- (1) 25 m³/h for passenger ships of less than 1,000 gross tonnage and for cargo ships of 2,000 gross tonnage and upwards; and
- (2) 15 m³/h for cargo ships of less than 2,000 gross tonnage.

In addition, if the emergency fire pump is the main supply of water for any fixed fire extinguishing system provided to protect the space where the main fire pumps and their sources of power supply are located, the pump shall have the capacity required above and additional capacity for that system (see also *MSC.1/Circ.1314*).

See also *IACS UI SC270 Rev.1*.

.2 Pressure at hydrants

When the pump is delivering the quantity of water required by 24.12.2.2.1.1, the pressure at any hydrants shall be not less than the minimum pressure required by this Part of the Rules for the classification of ships.

.3 Suction heads

The total suction head and the net positive suction head of the pump shall be determined having due regard to the requirements of the Convention and this Section on the pump capacity and on the hydrant pressure under all conditions of list, trim, roll and pitch likely to be encountered in service. The ballast condition of a ship on entering or leaving a dry dock need not be considered a service condition. See *IACS UI SC164 Rev.1* and *IACS UI SC178 Rev.1* (taking into account 24.1.1.1).

24.12.2.2.2 Diesel engines and fuel tank

.1 Starting of diesel engine

Any diesel-driven power source for the pump shall be capable of being readily started in its cold condition down to the temperature of 0°C by hand (manual) cranking. Where ready starting cannot be assured, if this is impracticable, or if lower temperatures are likely to be encountered, and if the room for the diesel driven power source is not heated, electric heating of the diesel engine cooling water or lubricating oil system shall be fitted, to the satisfaction of the *Register*. If hand (manual) starting is impracticable, the *Register* may permit compressed air, electricity, or other sources of stored energy, including hydraulic power or starting cartridges to be used as a means of starting. These means shall be such as to enable

the diesel-driven power source to be started at least six times within a period of 30 min and at least twice within the first 10 min.

.2 Fuel tank capacity

Any service fuel tank shall contain sufficient fuel to enable the pump to run on full load for at least 3 h and sufficient reserves of fuel shall be available outside the machinery space of category A to enable the pump to be run on full load for an additional 15 h.

24.13 ARRANGEMENT OF MEANS OF ESCAPE

24.13.1 Application

This head details the specifications for means of escape as required by Sections in this Part of the Rules for the classification of ships.

24.13.2 Passenger ships

24.13.2.1 Width of stairways

24.13.2.1.1 Basic requirements for stairway widths

Stairways shall not be less than 900 mm in clear width. The minimum clear width of stairways shall be increased by 10 mm for every one person provided for in excess of 90 persons. The total number of persons to be evacuated by such stairways shall be assumed to be two thirds of the crew and the total number of passengers in the areas served by such stairways. The width of the stairways shall not be inferior to those determined by 24.13.2.1.2.

24.13.2.1.2 Calculation method of stairway widths

.1 Basic principles of the calculation

- (1) This calculation method determines the minimum stairway width at each deck level, taking into account the consecutive stairways leading into the stairway under consideration.
- (2) It is the intention that the calculation method shall consider evacuation from enclosed spaces within each main vertical zone individually and take into account all of the persons using the stairway enclosures in each zone, even if they enter that stairway from another vertical zone.
- (3) For each main vertical zone the calculation shall be completed for the night-time (case 1) and daytime (case 2) and the largest dimension from either case used for determining the stairway width for each deck under consideration.
- (4) The calculation of stairway widths shall be based upon the

crew and passenger load on each deck. Occupant loads shall be rated by the designer for passenger and crew accommodation spaces, service spaces, control spaces and machinery spaces. For the purpose of the calculation the maximum capacity of a public space shall be defined by either of the following two values: the number of seats or similar arrangements, or the number obtained by assigning 2 m² of gross deck surface area to each person.

.2 Calculation method for minimum value

(1) Basic formulae

In considering the design of stairway widths for each individual case which allow for the timely flow of persons evacuating to the assembly stations from adjacent decks above and below, the following calculation methods shall be used (see figures 24.13.1 and 24.13.2):

| |
|---|
| when joining two decks: $W = (N_1 + N_2) \times 10 \text{ mm};$ |
| when joining three decks: $W = (N_1 + N_2 + 0.5N_3) \times 10 \text{ mm};$ |
| when joining four decks: $W = (N_1 + N_2 + 0.5N_3 + 0.25N_4) \times 10 \text{ mm};$ and |

when joining five decks or more decks, the width of the stairways shall be determined by applying the above formula for four decks to the deck under consideration and to the consecutive deck, where:

W = the required tread width between handrails of the stairway.
The calculated value of W may be reduced where available landing area S is provided in stairways at the deck level defined by subtracting P from Z , such that:
 $P = S \times 3.0 \text{ persons/m}^2$; and $P_{\text{max}} = 0.25Z$
where

| | |
|-------|--|
| $Z =$ | the total number of persons expected to be evacuated on the deck being considered |
| $P =$ | the number of persons taking temporary refuge on the stairway landing, which may be subtracted from Z to a maximum value of $P = 0.25Z$ (to be rounded down to the nearest whole number) |
| $S =$ | the surface area (m ²) of the landing, minus the surface area necessary for the opening of doors and minus the surface |

| | |
|-------|---|
| | area necessary for accessing the flow on stairs (see figure 24.13.1) |
| $N =$ | the total number of persons expected to use the stairway from each consecutive deck under consideration; N_1 is for the deck with the largest number of persons using that stairway; N_2 is taken for the deck with the next highest number of persons directly entering the stairway flow such that, when sizing the stairway width as each deck level, $N_1 > N_2 > N_3 > N_4$ (see figure 24.13.2). These decks are assumed to be on or upstream (i.e. away from the embarkation deck) of the deck being considered. |

(2) Distribution of persons

(2.1) The dimension of the means of escape shall be calculated on the basis of the total number of persons expected to escape by the stairway and through doorways, corridors and landings (see figure 24.13.3). Calculations shall be made separately for the two cases of occupancy of the spaces specified below. For each component part of the escape route, the dimension taken shall not be less than the largest dimension determined for each case:

Case 1: Passengers in cabins with maximum berthing capacity fully occupied; members of the crew in cabins occupied to 2/3 of maximum berthing capacity; and service spaces occupied by 1/3 of the crew.

Case 2: Passengers in public spaces occupied to 3/4 of maximum capacity, 1/3 of the crew distributed in public spaces; service spaces occupied by 1/3 of the crew; and crew accommodation occupied by 1/3 of the crew.

(2.2) The maximum number of persons contained in a main vertical zone, including persons entering stairways from another main vertical zone, shall not be assumed to be higher than the maximum

number of persons authorized to be carried on board for the calculation of stairway widths only.

Figure 24.13.1 Landing calculation for stairway width reduction

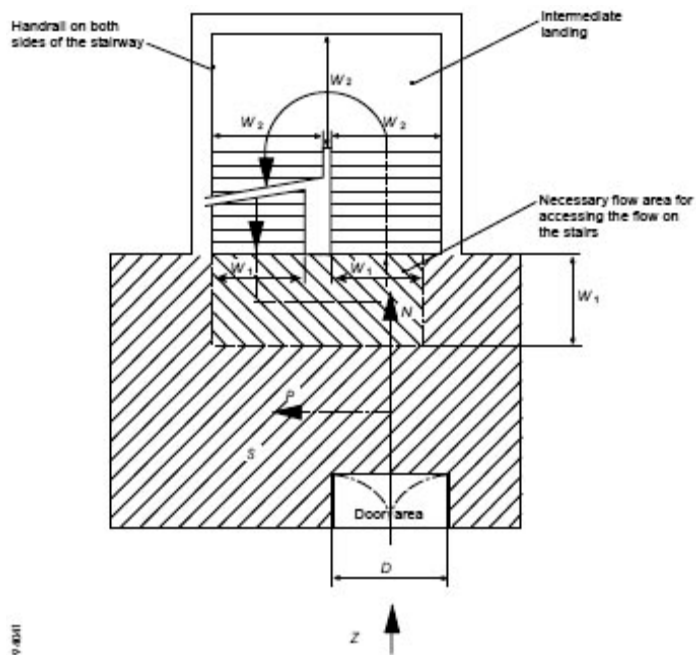

$P = S \times 3 \text{ persons/m}^2 =$ the number of persons taking refuge on the landing to a maximum of $P = 0.25Z$;

$N = Z - P =$ the number of persons directly entering the stairway flow from a given deck;

$Z =$ number of persons to be evacuated from the deck considered;

$S =$ available landing area (m^2) after subtracting the surface area necessary for movement and subtracting the space taken by the door swing area. Landing area is a sum of flow area, credit area and door area;

$D =$ width of exit doors to the stairway landing area (mm)

Figure 24.13.2 - Minimum stairway width (W) calculation example

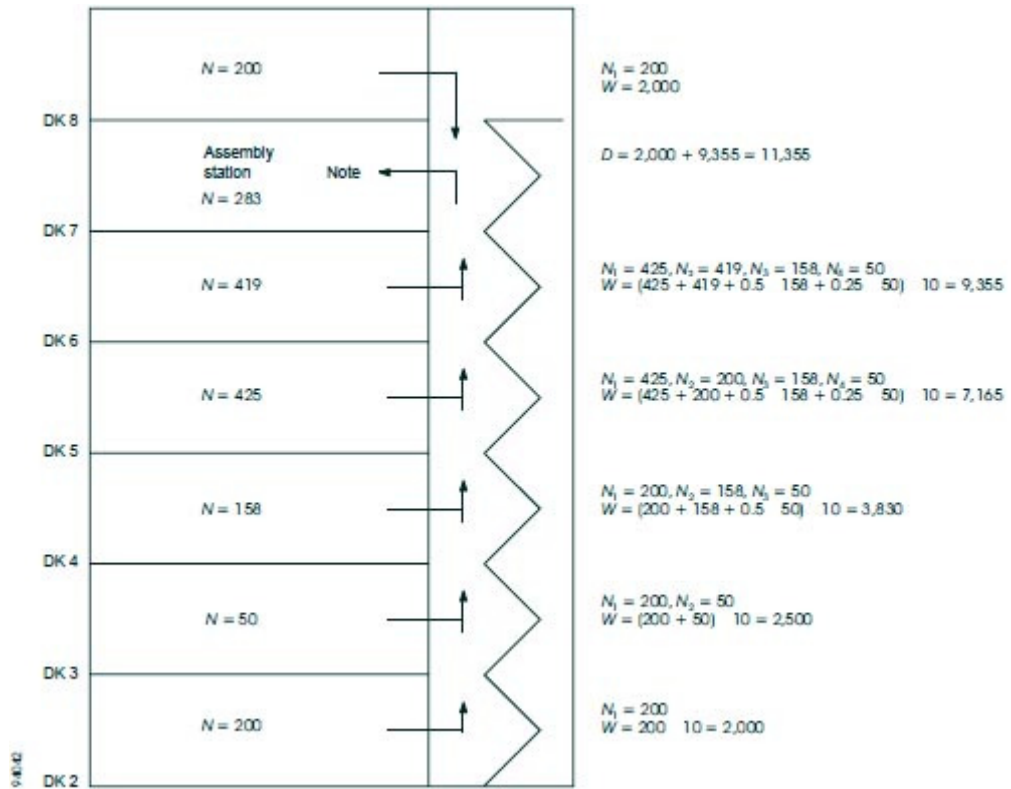

Z (pers) = number of persons expected to evacuate through the stairway

N (pers) = number of persons directly entering the stairway flow from a given deck

W (mm) = $(N_1 + N_2 + 0.5 \times N_3 + 0.25 \times N_4) \times 10$ = calculated width of stairway

D (mm) = width of exit doors

$N_1 > N_2 > N_3 > N_4$ where:

N_1 (pers) = the deck with the largest number of persons N entering directly the stairway

N_2 (pers) = the deck with the next largest number of persons N entering directly the stairway, etc.

Note: The doors to the assembly station shall have aggregate widths of 11,355 mm.

Figure 24.13.3 - Occupant loading calculation example

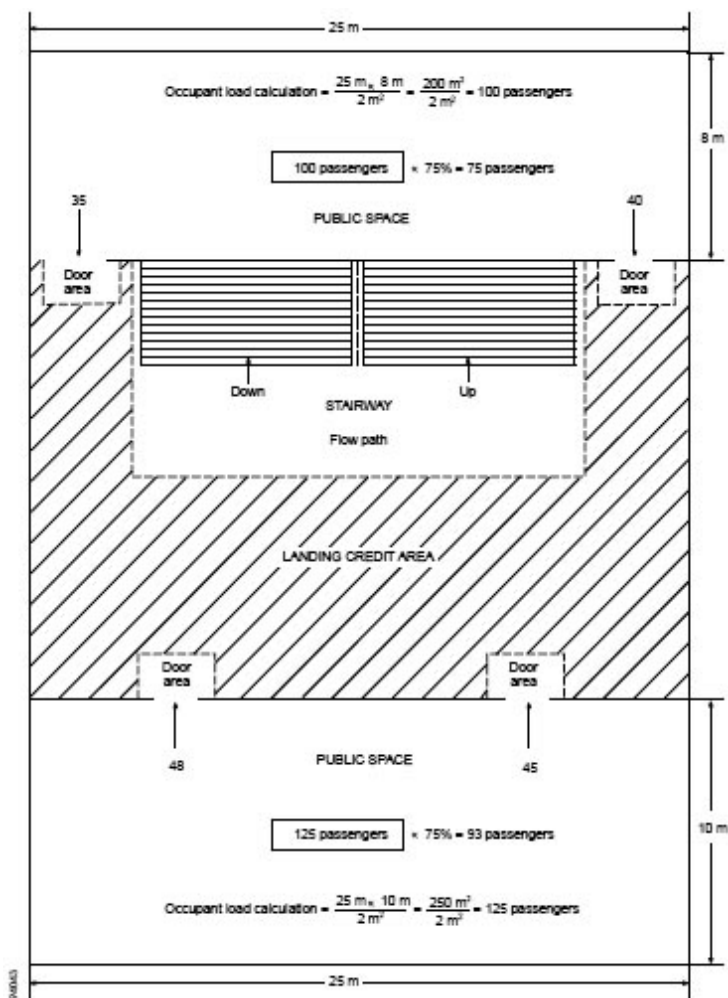

24.13.2.1.3 Prohibition of decrease in width in the direction to the assembly station

See Indication of the “assembly station” in passenger ships (MSC/Circ.777).

The stairway shall not decrease in width in the direction of evacuation to the assembly station. Where several assembly stations are in one main vertical zone, the stairway width shall not decrease in the direction of the evacuation to the most distant assembly station.

24.13.2.2 Details of stairways

24.13.2.2.1 Handrails

Stairways shall be fitted with handrails on each side. The maximum clear width between handrails shall be 1,800 mm.

24.13.2.2.2 Alignment of stairways

All stairways sized for more than 90 persons shall be aligned fore and aft.

24.13.2.2.3 Vertical rise and inclination

Stairways shall not exceed 3.5 m in vertical rise without the provision of a landing and shall not have an angle of inclination greater than 45°.

24.13.2.2.4 Landings

With the exception of intermediate landings, landings at each deck level shall be not less than 2 m² in area and shall increase by 1 m² for every 10 persons provided for in excess of 20 persons, but need not exceed 16 m², except for those landings servicing public spaces having direct access onto the stairway enclosure. Intermediate landings shall be sized in accordance with 24.13.2.3.1.

24.13.2.3 Doorways and corridors

24.13.2.3.1 Doorways and corridors and intermediate landings included in means of escape shall be sized in the same manner as stairways.

24.13.2.3.2 The aggregate width of stairway exit doors to the assembly station shall not be less than the aggregate width of stairways serving this deck.

24.13.2.4 Evacuation routes to the embarkation deck**24.13.2.4.1 Assembly station**

It shall be recognized that the evacuation routes to the embarkation deck may include an assembly station. In this case, consideration shall be given to the fire protection requirements and sizing of corridors and doors from the stairway enclosure to the assembly station and from the assembly station to the embarkation deck, noting that evacuation of persons from assembly stations to embarkation positions will be carried out in small control groups.

24.13.2.4.2 Routes from the assembly station to the survival craft embarkation position

Where the passengers and crew are held at an assembly station which is not at the survival craft embarkation position, the dimension of stairway width and doors from the assembly station to this position shall be based on the number of persons in the controlled group. The width of these stairways and doors need not exceed 1,500 mm unless larger dimensions are required for evacuation of these spaces under normal conditions.

24.13.2.5 Means of escape plans**24.13.2.5.1 Means of escape plans shall be provided indicating the following:**

- .1 the number of crew and passengers in all normally occupied spaces;
- .2 the number of crew and passengers expected to escape by stairway and through doorways, corridors and landings;
- .3 assembly stations and survival craft embarkation positions;
- .4 primary and secondary means of escape; and
- .5 width of stairways, doors, corridors and landing areas.

24.13.2.5.2 Means of escape plans shall be accompanied by detailed calculations for determining the width of escape stairways, doors, corridors and landing areas.

24.13.3 Cargo ships

Stairways and corridors used as means of escape shall be not less than 700 mm in clear width and shall have a handrail on one side. Stairways and corridors with a clear width of 1,800 mm and over shall have handrails on both sides. Clear width is considered the distance between the handrail and the bulkhead on the other side or between the handrails. The angle of inclination of stairways should be, in general, 45°, but not greater than 50°, and in machinery spaces and small spaces not more than 60°. Doorways which give access to a stairway shall be of the same size as the stairway.

24.14 FIXED DECK FOAM SYSTEMS**24.14.1 Application**

This head details the specifications of fixed deck foam systems which are required to be provided by Sections in this Part of the Rules for the classification of ships.

24.14.2 Engineering specifications**24.14.2.1 General**

24.14.2.1.1 The arrangements for providing foam shall be capable of delivering foam to the entire cargo tanks deck area as well as into any cargo tank the deck of which has been ruptured.

24.14.2.1.2 The deck foam system shall be capable of simple and rapid operation. See *IACS UI SC150 Rev.1* (taking into account 24.1.1.1).

24.14.2.1.3 Operation of a deck foam system at its required output shall permit the simultaneous use of the minimum required number of jets of water at the required pressure from the fire main. Where the deck foam system is supplied by a common line from the fire main, additional foam concentrate shall be provided for operation of two nozzles for the same period of time required for the foam system. The simultaneous use of the minimum required jets of water shall be possible on deck over the full length of the ship, in the accommodation, service spaces, control stations and machinery spaces.

24.14.2.2 Component requirements**24.14.2.2.1 Foam solution and foam concentrate****.1 For tankers carrying:**

- (1) crude oil or petroleum products having a flashpoint not exceeding 60°C (closed cup), as determined by an approved flashpoint apparatus, and a Reid vapour pressure which is below atmospheric pressure or other liquid products having a similar fire hazard, including cargoes in Chapter 18 of the IBC Code, having a flashpoint not exceeding 60°C (closed cup) for which a regular foam fire-fighting system is effective (refer to 3.1.2.48 and 10.8); or
- (2) petroleum products with a flashpoint exceeding 60°C (closed cup), as determined by an approved flashpoint apparatus (see 9.8.2); or
- (3) IBC Code Chapter 17 products with a flashpoint exceeding 60°C (closed cup) determined by an approved flashpoint apparatus (see 9.8.2 and paragraph 11.1.3 of the IBC Code),

the rate of supply of foam solution shall be not less than the greatest of the following:

- (1) 0.6 L/min per square metre of cargo tanks deck area, where cargo tanks deck area means the maximum breadth of the ship multiplied by the total longitudinal extent of the cargo tank spaces;
- (2) 6 L/min per square metre of the horizontal sectional area of the

- single tank having the largest such area; or
- (3) 3 L/min per square metre of the area protected by the largest monitor, such area being entirely forward of the monitor, but in no case should the output of any monitor be less than 1,250 L/min.
- .2 For tankers carrying chemicals in bulk listed in Chapter 17 of the IBC Code having a flashpoint not exceeding 60°C (closed cup), the rate of supply of foam solution shall be as required by the IBC Code.
- .3 Sufficient foam concentrate shall be supplied to ensure at least 20 min of foam generation in tankers fitted with an inert gas installation or 30 min of foam generation in tankers not fitted with an inert gas installation or not required to use an inert gas system.
- .4 The foam concentrate supplied on board shall be approved by the *Register*, see *Guidelines for performance and testing criteria and surveys of foam concentrates for fixed fire-extinguishing systems (MSC.1/Circ.1312 and MSC.1/Circ.1312/Corr.1)* for the cargoes intended to be carried. Type B foam concentrates shall be supplied for the protection of crude oil, petroleum products and non-polar solvent cargoes. Type A foam concentrates shall be supplied for polar solvent cargoes, as listed in the table of Chapter 17 of the IBC Code. Only one type of foam concentrate shall be supplied, and it shall be effective for the maximum possible number of cargoes intended to be carried. For cargoes for which foam is not effective or is incompatible, additional arrangements to the satisfaction of the *Register* shall be provided.
- .5 Liquid cargoes with a flashpoint not exceeding 60°C for which a regular foam fire-fighting system is not effective shall comply with the provisions of 24.6.6.

24.14.2.2.2 Monitors and foam applicators

- .1 Foam from the fixed foam system shall be supplied by means of monitors and foam applicators. Prototype tests of the monitors and foam applicators shall be performed to ensure the foam expansion and drainage time of the foam produced does not differ more than ±10% of that determined in 24.14.2.2.1.4. When medium expansion ratio foam (between 21:1 and 200:1 expansion ratio) is employed, the application rate of the foam and the capacity of a monitor installation shall be to the satisfaction of the Register. At least 50% of the foam solution supply rate required shall be delivered from each moni-

tor. On tankers of less than 4,000 tonnes deadweight the Register may not require installation of monitors but only applicators. However, in such a case the capacity of each applicator shall be at least 25% of the foam solution supply rate required.

- .2 The capacity of any applicator shall be not less than 400 L/min and the applicator throw in still air conditions shall be not less than 15 m.

24.14.2.3 Installation requirements

24.14.2.3.1 Main control station

See *IACS UI SCI50 Rev.1* (taking into account

24.1.1.1).

- .1 The main control station for the system shall be suitably located outside the cargo area, adjacent to the accommodation spaces and readily accessible and operable in the event of fire in the areas protected.

24.14.2.3.2 Monitors

- .1 The number and position of monitors shall be such as to comply with 24.14.2.1.1.
- .2 The distance from the monitor to the farthest extremity of the protected area forward of that monitor shall not be more than 75% of the monitor throw in still air conditions.
- .3 A monitor and hose connection for a foam applicator shall be situated both port and starboard at the front of the poop or accommodation spaces facing the cargo tanks deck. The monitors and hose connections shall be aft of any cargo tanks, but may be located in the cargo area above pump-rooms, cofferdams, ballast tanks and void spaces adjacent to cargo tanks if capable of protecting the deck below and aft of each other. On tankers of less than 4,000 tonnes deadweight, a hose connection for a foam applicator shall be situated both port and starboard at the front of the poop or accommodation spaces facing the cargo tanks deck. See *IACS UI SCI69, Rev.1* (taking into account 24.1.1.1). See also *MSC.1/Circ.1491*.

24.14.2.3.3 Applicators

- .1 At least four foam applicators shall be provided on all tankers. The number and disposition of foam main outlets shall be such that foam from at least two applicators can be directed on to any part of the cargo tanks deck area.
- .2 Applicators shall be provided to ensure flexibility of action during fire-fighting operations and to cover areas screened from the monitors.

24.14.2.3.4 Isolation valves

- .1 Valves shall be provided in the foam main, and in the fire main when this is an integral part of the deck foam system, immediately forward of any monitor position to isolate damaged sections of those mains.

24.15 INERT GAS SYSTEMS**24.15.1 Application**

This head details the specifications for inert gas systems as required by this Part of the Rules for the classification of ships.

24.15.2 Engineering specifications**24.15.2.1 Definitions**

For the purposes of this Section:

24.15.2.1.1 *Cargo tanks* means those cargo tanks, including slop tanks, which carry cargoes, or cargo residues, having a flashpoint not exceeding 60°C.

24.15.2.1.2 *Inert gas system* includes inert gas systems using flue gas, inert gas generators, and nitrogen generators and means the inert gas plant and inert gas distribution together with means for preventing backflow of cargo gases to machinery spaces, fixed and portable measuring instruments and control devices.

24.15.2.1.3 *Gas-safe space* is a space in which the entry of gases would produce hazards with regard to flammability or toxicity.

24.15.2.1.4 *Gas-free* is a condition in a tank where the content of hydrocarbon or other flammable vapour is less than 1% of the lower flammable limit (LFL), the oxygen content is at least 21%, and no toxic gases are present, see *Revised recommendations for entering enclosed spaces aboard ships (resolution A.1050(27))*.

24.15.2.2 Requirements for all systems**24.15.2.2.1 General**

- .1 The inert gas system referred to in this Part of the Rules for the classification of ships shall be designed, constructed and tested to the satisfaction of the *Register*. It shall be designed to be capable of rendering and maintaining the atmosphere of the relevant cargo tanks non-flammable, see *Revised standards for the design, testing and locating of devices to prevent the passage of flame into cargo tanks in tankers (MSC/Circ.677, as amended by MSC/Circ.1009 and MSC.1/Circ.1324)* and the *Revised factors to be taken into consideration when designing cargo tank venting and gas-freeing arrangements (MSC/Circ.731)*.
- .2 The system shall be capable of:
- (1) inerting empty cargo tanks and maintaining the atmosphere in

any part of the tank with an oxygen content not exceeding 8% by volume and at a positive pressure in port and at sea except when it is necessary for such a tank to be gas-free;

- (2) eliminating the need for air to enter a tank during normal operations except when it is necessary for such a tank to be gas-free;
 - (3) purging empty cargo tanks of hydrocarbon or other flammable vapours, so that subsequent gas-freeing operations will at no time create a flammable atmosphere within the tank;
 - (4) delivering inert gas to the cargo tanks at a rate of at least 125% of the maximum rate of discharge capacity of the ship expressed as a volume. For chemical tankers and chemical/product tankers, the *Register* may accept inert gas systems having a lower delivery capacity provided that the maximum rate of discharge of cargoes from cargo tanks being protected by the system is restricted to not more than 80% of the inert gas capacity; and
 - (5) delivering inert gas with an oxygen content of not more than 5% by volume to the cargo tanks at any required rate of flow.
- .3 Materials used in inert gas systems shall be suitable for their intended purpose. In particular, those components which may be subjected to corrosive action of the gases and/or liquids are to be either constructed of corrosion-resistant material or lined with rubber, glass fibre epoxy resin or other equivalent coating material.
- .4 The inert gas supply may be:
- (1) treated flue gas from main or auxiliary boilers, or
 - (2) gas from an oil or gas-fired gas generator, or
 - (3) gas from nitrogen generators.
- Register* may accept systems using inert gases from one or more separate gas generators or other sources or any combination thereof, provided that an equivalent level of safety is achieved. Such systems shall, as far as practicable, comply with the requirements of this Chapter. Systems using stored carbon dioxide shall not be permitted unless the *Register* is satisfied that the risk of ignition from generation of static electricity by the system itself is minimized.

24.15.2.2.2 Safety measures

- .1 The inert gas system shall be so designed that the maximum pressure which it can

- exert on any cargo tank will not exceed the test pressure of any cargo tank.
- .2 Automatic shutdown of the inert gas system and its components parts shall be arranged on predetermined limits being reached, taking into account the provisions of 24.15.2.2.4, 24.15.2.3.2 and 24.15.2.4.2. See IACS UI SC284 and *MSC.1/Circ.1582/Rev.1*.
 - .3 Suitable shutoff arrangements shall be provided on the discharge outlet of each generator plant.
 - .4 The system shall be designed to ensure that if the oxygen content exceeds 5% by volume, the inert gas shall be automatically vented to atmosphere.
 - .5 Arrangements shall be provided to enable the functioning of the inert gas plant to be stabilized before commencing cargo discharge. If blowers are to be used for gas-freeing, their air inlets shall be provided with blanking arrangements.
 - .6 Where a double block and bleed valve is installed, the system shall ensure upon loss of power, the block valves are automatically closed and the bleed valve is automatically open.

24.15.2.2.3 System components

- .1 *Non-return devices*
 - (1) At least two non-return devices shall be fitted in order to prevent the return of vapour and liquid to the inert gas plant, or to any gas-safe spaces.
 - (2) The first non-return device shall be a deck seal of the wet, semi-wet, or dry type or a double-block and bleed arrangement. Two shut-off valves in series with a venting valve in between, may be accepted provided:
 - (2.1) the operation of the valve is automatically executed. Signal(s) for opening/closing is (are) to be taken from the process directly, e.g. inert gas flow or differential pressure; and
 - (2.2) alarm for faulty operation of the valves is provided, e.g. the operation status of "blower stop" and "supply valve(s) open" is an alarm condition. See IACS UI SC285.
 - (3) The second non-return device shall be a non-return valve or equivalent capable of preventing the return of vapours and liquids and fitted between the deck water seal (or equivalent device) and the first connection from the inert gas main to a cargo tank. It shall be provided with positive means of closure. As an alternative to positive means of closure, an additional valve having such means of closure may be provided between the non-return valve and the first connection to the cargo tanks to isolate the deck water seal, or equivalent device, from the inert gas main to the cargo tanks.
- (4) A water seal, if fitted, shall be capable of being supplied by two separate pumps, each of which shall be capable of maintaining an adequate supply at all times. The audible and visual alarm on the low level of water in the water seal shall operate at all times.
- (5) The arrangement of the water seal, or equivalent devices, and its associated fittings shall be such that it will prevent backflow of vapours and liquids and will ensure the proper functioning of the seal under operating conditions.
- (6) Provision shall be made to ensure that the water seal is protected against freezing, in such a way that the integrity of seal is not impaired by overheating.
- (7) A water loop or other approved arrangement shall also be fitted to each associated water supply and drain pipe and each venting or pressure-sensing pipe leading to gas-safe spaces. Means shall be provided to prevent such loops from being emptied by vacuum.
- (8) Any water seal, or equivalent device, and loop arrangements shall be capable of preventing return of vapours and liquids to an inert gas plant at a pressure equal to the test pressure of the cargo tanks.
- (9) The non-return devices shall be located in the cargo area on deck.
- .2 *Inert gas lines*
 - (1) The inert gas main may be divided into two or more branches downstream of the non-return devices required by 24.15.2.2.3.1. See *MSC.1/Circ.1582/Rev.1*.
 - (2) The inert gas main shall be fitted with branch piping leading to the cargo tank. Branch piping for inert gas shall be fitted with either stop valves or equivalent means of control for isolating each tank. Where stop valves are fitted, they shall be provided with locking arrangements. The control system shall provide unambiguous information of the operational status of such valves to at least the con-

- trol panel required in 24.15.2.2.4. See *MSC.1/Circ.1582/Rev.1*.
- (3) Each cargo tank not being inerted shall be capable of being separated from the inert gas main by:
- (3.1) removing spool-pieces, valves or other pipe sections, and blanking the pipe ends; or
 - (3.2) arrangement of two spectacle flanges in series with provisions for detecting leakage into the pipe between the two spectacle flanges; or
 - (3.3) equivalent arrangements to the satisfaction of the Register, providing at least the same level of protection.
- (4) Means shall be provided to protect cargo tanks against the effect of overpressure or vacuum caused by thermal variations and/or cargo operations when the cargo tanks are isolated from the inert gas mains.
- (5) Piping systems shall be so designed as to prevent the accumulation of cargo or water in the pipelines under all normal conditions.
- (6) Arrangements shall be provided to enable the inert gas main to be connected to an external supply of inert gas. The arrangements shall consist of a 250 mm nominal pipe size bolted flange, isolated from the inert gas main by a valve and located downstream of the non-return valve. The design of the flange should conform to the appropriate class in the standards adopted for the design of other external connections in the ship's cargo piping system. See *MSC.1/Circ.1582/Rev.1*.
- (7) If a connection is fitted between the inert gas main and the cargo piping system, arrangements shall be made to ensure an effective isolation having regard to the large pressure difference which may exist between the systems. This shall consist of two shutoff valves with an arrangement to vent the space between the valves in a safe manner or an arrangement consisting of a spool-piece with associated blanks.
- (8) The valve separating the inert gas main from the cargo main and which is on the cargo main side shall be a non-return valve with a positive means of closure.
- (9) Inert gas piping systems shall not pass through accommodation, service and control station spaces.
- (10) In combination carriers, the arrangement to isolate the slop tanks containing oil or oil residues from other tanks shall consist of blank flanges which will remain in position at all times when cargoes other than oil are being carried except as provided for in the relevant section of the guidelines developed by IMO, see *Revised Guidelines for inert gas systems (MSC/Circ.353)*, as amended by *MSC/Circ.387*.
- See *IACS UI SC62 Rev.2* (taking into account 24.1.1.1).
- 24.15.2.2.4 Indicators and alarms**
- .1 The operation status of the inert gas system shall be indicated in a control panel. See *IACS UI SC286*. See *MSC.1/Circ.1582/Rev.1*.
 - .2 Instrumentation shall be fitted for continuously indicating and permanently recording, when inert gas is being supplied:
 - (1) the pressure of the inert gas mains downstream of the non-return devices (see *MSC.1/Circ.1582/Rev.1*); and
 - (2) the oxygen content of the inert gas.
 - .3 The indicating and recording devices shall be placed in the cargo control room where provided. But where no cargo control room is provided, they shall be placed in a position easily accessible to the officer in charge of cargo operations.
 - .4 In addition, meters shall be fitted:
 - (1) in the navigating bridge to indicate at all times the pressure referred to in 24.15.2.2.4.2(1) and the pressure in the slop tanks of combination carriers, whenever those tanks are isolated from the inert gas main; and
 - (2) in the machinery control room or in the machinery space to indicate the oxygen content referred to in 24.15.2.2.4.2(2).
 - .5 *Audible and visual alarms*
 - (1) Audible and visual alarms shall be provided, based on the system designed, to indicate:
 - (1.1) oxygen content in excess of 5% by volume;
 - (1.2) failure of the power supply to the indicating devices as referred to in 24.15.2.2.4.2;
 - (1.3) gas pressure less than 100 mm water gauge. The alarm arrangement shall be such as to ensure that the pres-

- sure in slop tanks in combination carriers can be monitored at all times;
- (1.4) high-gas pressure; and
 - (1.5) failure of the power supply to the automatic control system.
- (2) The alarms required in 24.15.2.2.4.5(1.1), 24.15.2.2.4.5(1.3) and 24.15.2.2.4.5(1.5) shall be fitted in the machinery space and cargo control room, where provided, but in each case in such a position that they are immediately received by responsible members of the crew.
 - (3) An audible alarm system independent of that required in 24.15.2.2.4.5(1.3) or automatic shutdown of cargo pumps shall be provided to operate on predetermined limits of low pressure in the inert gas main being reached. See *MSC.1/Circ.1582/Rev.1*.
 - (4) Two oxygen sensors shall be positioned at appropriate locations in the space or spaces containing the inert gas system. If the oxygen level falls below 19%, these sensors shall trigger alarms, which shall be both visible and audible inside and outside the space or spaces and shall be placed in such a position that they are immediately received by responsible members of the crew.

See IACS UI SC287.

24.15.2.2.5 Instruction manuals

Detailed instruction manuals shall be provided on board, covering the operations, safety and maintenance requirements and occupational health hazards relevant to the inert gas system and its application to the cargo tank system, see *Revised Guidelines for inert gas systems (MSC/Circ.353), as amended by MSC/Circ.387*. The manuals shall include guidance on procedures to be followed in the event of a fault or failure of the inert gas system.

24.15.2.3 Requirements for flue gas and inert gas generator systems

In addition to the provisions in 24.15.2.2, for inert gas systems using flue gas or inert gas generators, the provisions of this sub-item shall apply.

24.15.2.3.1 System requirements

.1 Inert gas generators

- (1) Two fuel oil pumps shall be fitted to the inert gas generator. Suitable fuel in sufficient quantity shall be provided for the inert gas generators.

- (2) The inert gas generators shall be located outside the cargo tank area. Spaces containing inert gas generators shall have no direct access to accommodation service or control station spaces, but may be located in machinery spaces. If they are not located in machinery spaces, such a compartment shall be separated by a gastight steel bulkhead and/or deck from accommodation, service and control station spaces. Adequate positive-pressure-type mechanical ventilation shall be provided for such a compartment.

.2 Gas regulating valves

- (1) A gas regulating valve shall be fitted in the inert gas main. This valve shall be automatically controlled to close, as required in 24.15.2.2.2. It shall also be capable of automatically regulating the flow of inert gas to the cargo tanks unless means are provided to automatically control the inert gas flow rate.
- (2) The gas regulating valve shall be located at the forward bulkhead of the forward most gas-safe space through which the inert gas main passes.

.3 Cooling and scrubbing arrangement

- (1) Means shall be fitted which will effectively cool the volume of gas specified in 24.15.2.2.1.2 and remove solids and sulphur combustion products. The cooling water arrangements shall be such that an adequate supply of water will always be available without interfering with any essential services on the ship. Provision shall also be made for an alternative supply of cooling water.
- (2) Filters or equivalent devices shall be fitted to minimize the amount of water carried over to the inert gas blowers.

.4 Blowers

- (1) At least two inert gas blowers shall be fitted and be capable of delivering to the cargo tanks at least the volume of gas required by 24.15.2.2.1.2. For systems fitted with inert gas generators the *Register* may permit only one blower if that system is capable of delivering the total volume of gas required by 24.15.2.2.1.2 to the cargo tanks, provided that sufficient spares for the blower and its prime mover are carried on board to enable any failure of the blower

and its prime mover to be rectified by the ship's crew.

- (2) Where inert gas generators are served by positive displacement blowers, a pressure relief device shall be provided to prevent excess pressure being developed on the discharge side of the blower.
- (3) When two blowers are provided, the total required capacity of the inert gas system shall be divided evenly between the two and in no case is one blower to have a capacity less than 1/3 of the total required.

.5 *Inert gas isolating valves*

For systems using flue gas, flue gas isolating valves shall be fitted in the inert gas mains between the boiler uptakes and the flue gas scrubber. These valves shall be provided with indicators to show whether they are open or shut, and precautions shall be taken to maintain them gastight and keep the seatings clear of soot. Arrangements shall be made to ensure that boiler soot blowers cannot be operated when the corresponding flue gas valve is open.

.6 *Prevention of flue gas leakage*

- (1) Special consideration shall be given to the design and location of scrubber and blowers with relevant piping and fittings in order to prevent flue gas leakages into enclosed spaces.
- (2) To permit safe maintenance, an additional water seal or other effective means of preventing flue gas leakage shall be fitted between the flue gas isolating valves and scrubber or incorporated in the gas entry to the scrubber.

24.15.2.3.2 Indicators and alarms

- .1 In addition to the requirements in 24.15.2.2.4.2, means shall be provided for continuously indicating the temperature of the inert gas at the discharge side of the system, whenever it is operating.
- .2 In addition to the requirements of 24.15.2.2.4.5, audible and visual alarms shall be provided to indicate:
 - (1) insufficient fuel oil supply to the oil-fired inert gas generator;
 - (2) failure of the power supply to the generator;
 - (3) low water pressure or low water flow rate to the cooling and scrubbing arrangement;
 - (4) high water level in the cooling and scrubbing arrangement;
 - (5) high gas temperature;
 - (6) failure of the inert gas blowers; and

- (7) low water level in the water seal.

24.15.2.4 Requirements for nitrogen generator systems

In addition to the provisions in 24.15.2.2, for inert gas systems using nitrogen generators, the provisions of this sub-item shall apply.

24.15.2.4.1 System requirements

- .1 The system shall be provided with one or more compressors to generate enough positive pressure to be capable of delivering the total volume of gas required by 24.15.2.2.1.2.
- .2 A feed air treatment system shall be fitted to remove free water, particles and traces of oil from the compressed air.
- .3 The air compressor and nitrogen generator may be installed in the engine-room or in a separate compartment. A separate compartment and any installed equipment shall be treated as an "Other machinery space" with respect to fire protection. Where a separate compartment is provided for the nitrogen generator, the compartment shall be fitted with an independent mechanical extraction ventilation system providing six air changes per hour. The compartment is to have no direct access to accommodation spaces, service spaces and control stations.
- .4 Where a nitrogen receiver or a buffer tank is installed, it may be installed in a dedicated compartment, in a separate compartment containing the air compressor and the generator, in the engine room, or in the cargo area. Where the nitrogen receiver or a buffer tank is installed in an enclosed space, the access shall be arranged only from the open deck and the access door shall open outwards. Adequate, independent mechanical ventilation, of the extraction type, shall be provided for such a compartment.

24.15.2.4.2 Indicators and alarms

- .1 In addition to the requirements in 24.15.2.2.4.2, instrumentation is to be provided for continuously indicating the temperature and pressure of air at the suction side of the nitrogen generator.
- .2 In addition to the requirements in 24.15.2.2.4.5, audible and visual alarms shall be provided to include:
 - (1) failure of the electric heater, if fitted;
 - (2) low feed-air pressure or flow from the compressor;
 - (3) high-air temperature; and
 - (4) high condensate level at automatic drain of water separator.

24.15.3 Additional requirements (IACS UR F20 Rev. 7)

24.15.3.1 General Requirements

24.15.3.1.1 All types of inert gas systems are to comply with the following:

- .1 Plans in diagrammatic form are to be submitted for appraisal and should include the following:
 - details and arrangement of the inert gas generating plant including all control and monitoring devices;
 - arrangement of the piping system for distribution of the inert gas.
- .2 An automatic control capable of producing suitable inert gas under all service conditions is to be fitted.
- .3 Subsequent surveys are to be carried out at the intervals required by the *Register*.

24.15.3.2 Requirements for All Systems on Tankers, including Chemical Tankers, to which 4.5.5.1 applies

24.15.3.2.1 An inert gas system complying with the applicable requirements of 24.15.1 and 24.15.2 is to be fitted on tankers to which 4.5.5.1 applies. In applying the applicable requirements of 24.15.1 and 24.15.2, any use of the word "Administration" therein is to be considered as meaning the *Register*. The inert gas system is to be operated in accordance with 16.3.3. In applying 16.3.3.2, 24.15.2.2.1.2(4) is to be complied with.

24.15.3.3 Additional Requirements for Nitrogen Generator Systems on Tankers, including Chemical Tankers, to which 4.5.5.1 applies

24.15.3.3.1 The following requirements apply where a nitrogen generator system is fitted on board as required by 4.5.5.1. For the purpose, the inert gas is to be produced by separating air into its component gases by passing compressed air through a bundle of hollow fibres, semi-permeable membranes or adsorber materials.

24.15.3.3.2 In addition to the applicable requirements of 24.15.1 and 24.15.2, the nitrogen generator system is to comply with 4.5.3.4.2, 4.5.6.3 and 11.6.3.4.

24.15.3.3.3 A nitrogen generator is to consist of a feed air treatment system and any number of membrane or adsorber modules in parallel necessary to meet 24.15.2.2.1.2(4).

24.15.3.3.4 The nitrogen generator is to be capable of delivering high purity nitrogen in accordance with 24.15.2.2.1.2(5). In addition to 24.15.2.2.4, the system is to be fitted with automatic means to discharge "off-spec" gas to the atmosphere during start-up and abnormal operation.

24.15.3.3.5 The system is to be provided with one or more compressors to generate enough positive pressure to be capable of delivering the total volume of gas required by 24.15.2.2.1.2. Where two compressors are provided, the total required capacity of the system is preferably to be divided equally between the two compressors, and in no case is one compressor to have a capacity less than 1/3 of the total capacity required.

24.15.3.3.6 The feed air treatment system fitted to remove free water, particles and traces of oil from the compressed air as required by 24.15.2.4.1.2, is also to preserve the specification temperature.

24.15.3.3.7 The oxygen-enriched air from the nitrogen generator and the nitrogen-product enriched gas from the protective devices of the nitrogen receiver are to be discharged to a *safe location* on the open deck.

"Safe location" needs to address the two types of discharges separately:

1. oxygen-enriched air from the nitrogen generator - safe locations on the open deck are:
 - outside of hazardous area;
 - not within 3m of areas traversed by personnel; and
 - not within 6m of air intakes for machinery (engines and boilers) and all ventilation inlets.
2. nitrogen-product enriched gas from the protective devices of the nitrogen receiver- safe locations on the open deck are:
 - not within 3m of areas traversed by personnel; and
 - not within 6m of air intakes for machinery (engines and boilers) and all ventilation inlets/outlets.

24.15.3.3.8 In order to permit maintenance, means of isolation are to be fitted between the generator and the receiver.

24.15.3.4 Nitrogen / Inert Gas Systems Fitted for Purposes other than Inerting Required by 4.5.5.1 and 4.5.5.2

24.15.3.4.1 This sub-item applies to systems fitted on oil tankers, gas tankers or chemical tankers to which 4.5.5.1 and 4.5.5.2 do not apply.

24.15.3.4.2 Requirements in 24.15.2.2.2.2, 24.15.2.2.4, 24.15.2.2.4.2, 24.15.2.2.4.3, 24.15.2.2.4.5(1.1), 24.15.2.2.4.5(1.2), 24.15.2.2.4.5(4), 24.15.2.4.1.1, 24.15.2.4.1.2, 24.15.2.4.1.3, 24.15.2.4.1.4, 24.15.2.4.2.1 and 24.15.2.4.2.2, as applicable apply to the systems.

24.15.3.4.3 The requirements of 24.15.3.3 apply except paragraphs 24.15.3.3.1, 24.15.3.3.2, 24.15.3.3.3 and 24.15.3.3.5.

24.15.3.4.4 Materials used in inert gas systems are to be suitable for their intended purpose in accordance with the Rules for the classification of ships of the *Register*.

24.15.3.4.5 All the equipment is to be installed on board and tested under working conditions to the satisfaction of the Surveyor.

24.15.3.4.6 The two non-return devices as required by 24.15.2.2.3.1(1) are to be fitted in the inert gas main. The non-return devices are to comply with 24.15.2.2.3.1(2) and 24.15.2.2.3.1(3); however, where the connections to the cargo tanks, to the hold spaces or to cargo piping are not permanent, the non-return devices required by 24.15.2.2.3.1(1) may be substituted by two non-return valves.

24.16 FIXED HYDROCARBON GAS DETECTION SYSTEMS

24.16.1 Application

24.16.1.1 This head details the specifications for fixed hydrocarbon gas detection systems as required by Sections in this Part of the Rules for the classification of ships.

24.16.1.2 A combined gas detection system required by 4.5.7.3 4.5.10 may be accepted in cases where the system fully complies with the requirement of Section 2.

24.16.2 Engineering specifications

24.16.2.1 General

24.16.2.1.1 The fixed hydrocarbon gas detection system referred to in this Part of the Rules for the classification of ships shall be designed, constructed and tested to the satisfaction of the *Register* based on performance standards developed by the IMO, see *Guidelines for the design, construction and testing of fixed hydrocarbon gas detection systems (MSC.1/Circ.1370)*.

24.16.2.1.2 The system shall be comprised of a central unit for gas measurement and analysis and gas sampling pipes in all ballast tanks and void spaces of double-hull and double-bottom spaces adjacent to the cargo tanks, including the fore-peak tank and any other tanks and spaces under the bulkhead deck adjacent to cargo tanks.

24.16.2.1.3 The system may be integrated with the cargo pump-room gas detection system, provided that the spaces referred to in 24.16.2.1.2 are sampled at the rate required in 24.16.2.3.1. Continuous sampling from other locations may also be considered provided the sampling rate is complied with.

24.16.2.2 Component requirements

24.16.2.2.1 Gas sampling lines

- .1 Common sampling lines to the detection equipment shall not be fitted, except the lines serving each pair of sampling points as required in 24.16.2.2.1.3.
- .2 The materials of construction and the dimensions of gas sampling lines shall be such as to prevent restriction. Where non-metallic materials are used, they shall be electrically conductive. The gas sampling lines shall not be made of aluminium.
- .3 The configuration of gas sampling lines shall be adapted to the design and size of each space. Except as provided in 24.16.2.2.1.4 and 24.16.2.2.1.5, the sampling system shall allow for a minimum of two hydrocarbon gas sampling points, one located on the lower and one on the upper part where sampling is required. When required, the upper gas sampling point shall not be located lower than 1 m from the tank top. The position of the lower located gas sampling point shall be

above the height of the girder of bottom shell plating but at least 0.5 m from the bottom of the tank and it shall be provided with means to be closed when clogged. In positioning the fixed sampling points, due regard should also be given to the density of vapours of the oil products intended to be transported and the dilution from space purging or ventilation.

- .4 For ships with a deadweight of less than 50,000 tonnes, the *Register* may allow the installation of one sampling location for each tank for practical and/or operational reasons.
- .5 For ballast tanks in the double-bottom, ballast tanks not intended to be partially filled and void spaces, the upper gas sampling point is not required.
- .6 Means shall be provided to prevent gas sampling lines from clogging when tanks are ballasted by using compressed air flushing to clean the line after switching from ballast to cargo loaded mode. The system shall have an alarm to indicate if the gas sampling lines are clogged.

See *IACS Rec. No. 123* (taking into account

24.1.1.1).

24.16.2.2.2 Gas analysis unit

- .1 The gas analysis unit shall be located in a safe space and may be located in areas outside the ship's cargo area; for example, in the cargo control room and/or navigation bridge in addition to the hydraulic room when mounted on the forward bulkhead, provided the following requirements are observed:
 - (1) sampling lines shall not run through gas safe spaces, except where permitted under subparagraph .5;
 - (2) the hydrocarbon gas sampling pipes shall be equipped with flame arresters. Sample hydrocarbon gas is to be led to the atmosphere with outlets arranged in a safe location, not close to a source of ignitions and not close to the accommodation area air intakes;
 - (3) a manual isolating valve, which shall be easily accessible for operation and maintenance, shall be fitted in each of the sampling lines at the bulkhead on the gas safe side;
 - (4) the hydrocarbon gas detection equipment including sample piping, sample pumps, solenoids, analysing units etc., shall be located in a reasonably gas-tight cabinet (e.g., fully enclosed steel cabinet with a door with gaskets) which is to be monitored by its own sampling point. At a gas concentra-

- tion above 30% of the lower flammable limit inside the steel enclosure the entire gas analysing unit is to be automatically shut down; and
- (5) where the enclosure cannot be arranged directly on the bulkhead, sample pipes shall be of steel or other equivalent material and without detachable connections, except for the connection points for isolating valves at the bulkhead and analysing unit, and are to be routed on their shortest ways.

24.16.2.2.3 Gas detection equipment

- .1 The gas detection equipment shall be designed to sample and analyse from each sampling line of each protected space, sequentially at intervals not exceeding 30 min.
- .2 Means shall be provided to enable measurements with portable instruments in case the fixed system is out of order, or for system calibration. In case the system is out of order, procedures shall be in place to continue to monitor the atmosphere with portable instruments and to record the measurement results.
- .3 Audible and visual alarms are to be initiated in the cargo control room, navigation bridge and at the analysing unit when the vapour concentration in a given space reaches a pre-set value, which shall not be higher than the equivalent of 30% of the lower flammable limit.
- .4 The gas detection equipment shall be so designed that it may readily be tested and calibrated.

**24.17 HELICOPTER FACILITY
FOAM FIREFIGHTING APPLIANCES**

24.17.1 Application

This item details the specifications for foam firefighting appliances for the protection of helidecks and helicopter landing areas as required by this part of the Rules for the classification of ships.

24.17.2 Definitions

24.17.2.1 D-value means the largest dimension of the helicopter used for assessment of the helideck when its rotors are turning. It establishes the required area of foam application.

24.17.2.2 Deck integrated foam nozzles are foam nozzles recessed into or edge mounted on the helideck.

24.17.2.3 Foam-making branch pipes are air-aspirating nozzles in tube shape for producing and discharging foam, usually in straight stream only.

24.17.2.4 Helicopter landing area is as defined in 3.1.2.57.

24.17.2.5 Helideck is as defined in 3.1.2.26.

24.17.2.6 Hose reel foam station is a hose reel fitted with a foam-making branch pipe and non-collapsible hose, together with fixed foam proportioner and fixed foam concentrate tank, mounted on a common frame.

24.17.2.7 Monitor foam station is a foam monitor, either self-inducing or together with separate fixed foam proportioner, and fixed foam concentrate tank, mounted on a common frame.

24.17.2.8 Obstacle free sector is the take-off and approach sector which totally encompasses the safe landing area and extends over a sector of at least 210°, within which only specified obstacles are permitted.

24.17.2.9 Limited obstacle sector is a 150° sector outside the take-off and approach sector that extends outward from a helideck where objects of limited height are permitted.

24.17.3 Engineering specifications for helidecks and helicopter landing areas

24.17.3.1 The system shall be capable of manual release, and may be arranged for automatic release.

24.17.3.2 For helidecks the foam system shall contain at least two fixed foam monitors or deck integrated foam nozzles. In addition, at least two hose reels fitted with a foam-making branch pipe and non-collapsible hose sufficient to reach any part of the helideck shall be provided. The minimum foam system discharge rate shall be determined by multiplying the D-value area by 6 l/min/m². The minimum foam system discharge rate for deck integrated foam nozzle systems shall be determined by multiplying the overall helideck area by 6 l/min/m². Each monitor shall be capable of supplying at least 50% of the minimum foam system discharge rate, but not less than 500 l/min. The minimum discharge rate of each hose reel shall be at least 400 l/min. The quantity of foam concentrate shall be adequate to allow operation of all connected discharge devices for at least 5 min.

24.17.3.3 Where foam monitors are installed, the distance from the monitor to the farthest extremity of the protected area shall be not more than 75% of the monitor throw in still air conditions.

24.17.3.4 For helicopter landing areas, at least two portable foam applicators or two hose reel foam stations shall be provided, each capable of discharging a minimum foam solution discharge rate, in accordance with the following table.

| Category | Helicopter overall length (D-value) | Minimum foam solution discharge rate (l/min) |
|----------|--|--|
| H1 | up to but not including 15 m | 250 |
| H2 | from 15 m up to but not including 24 m | 500 |
| H3 | from 24 m up to but not including 35 m | 800 |

The quantity of foam concentrate shall be adequate to allow operation of all connected discharge devices

for at least 10 min. For tankers fitted with a deck foam system, the Administration may consider an alternative arrangement, taking into account the type of foam concentrate to be used.

24.17.3.5 Manual release stations capable of starting necessary pumps and opening required valves, including the fire main system, if used for water supply, shall be located at each monitor and hose reel. In addition, a central manual release station shall be provided at a protected location. The foam system shall be designed to discharge foam with nominal flow and at design pressure from any connected discharge devices within 30 s of activation.

24.17.3.6 Activation of any manual release station shall initiate the flow of foam solution to all connected hose reels, monitors, and deck integrated foam nozzles.

24.17.3.7 The system and its components shall be designed to withstand ambient temperature changes, vibration, humidity, shock impact and corrosion normally encountered on the open deck, and shall be manufactured and tested to the satisfaction of the Register.

24.17.3.8 A minimum nozzle throw of at least 15 m shall be provided with all hose reels and monitors discharging foam simultaneously. The discharge pressure, flow rate and discharge pattern of deck integrated foam nozzles shall be to the satisfaction of the Register, based on tests that demonstrate the nozzle's capability to extinguish fires involving the largest size helicopter for which the helideck is designed.

24.17.3.9 Monitors, foam-making branch pipes, deck integrated foam nozzles and couplings shall be constructed of brass, bronze or stainless steel. Piping, fittings and related components, except gaskets, shall be designed to withstand exposure to temperatures up to 925°C.

24.17.3.10 The foam concentrate shall be demonstrated effective for extinguishing aviation fuel spill fires and shall conform to performance standards not inferior to those acceptable to the IMO, refer to the *International Civil Aviation Organization Airport Services Manual, part 1, Rescue and Fire Fighting, Chapter 8, Extinguishing Agent Characteristics, paragraph 8.1.5, Foam specifications table 8-1, Performance Level B, or to the Revised Guidelines for the performance and testing criteria, and surveys of foam concentrates for fixed fire-extinguishing systems (MSC.1/Circ.1312)*.

Where the foam storage tank is on the exposed deck, freeze protected foam concentrates shall be used, if appropriate, for the area of operation.

24.17.3.11 Any foam system equipment installed within the take-off and approach obstacle-free sector shall not exceed a height of 0.25 m. Any foam system equipment installed in the limited obstacle sector shall not exceed the height permitted for objects in this area.

24.17.3.12 All manual release stations, monitor foam stations, hose reel foam stations, hose reels and monitors shall be provided with a means of access that does not require travel across the helideck or helicopter landing area.

24.17.3.13 Oscillating monitors, if used, shall be pre-set to discharge foam in a spray pattern and have a means of disengaging the oscillating mechanism to allow rapid conversion to manual operation.

24.17.3.14 If a foam monitor with flow rate up to 1,000 l/min is installed, it shall be equipped with an air-aspirating nozzle. If a deck integrated nozzle system is installed, then the additionally installed hose reel shall be equipped with an air-aspirating handline nozzle (foam branch pipes). Use of non-air-aspirating foam nozzles (on both monitors and the additional hose reel) is permitted only where foam monitors with a flow rate above 1,000 l/min are installed. If only portable foam applicators or hose reel stations are provided, these shall be equipped with an air-aspirating handline nozzle (foam branch pipes).

24.18 DRENCHING SYSTEM

24.18.1 Water supply for the drenching system intended for protection of superstructures and deckhouses in oil recovery ships (see 9.10.9) shall be by an independent power pump.

The system shall have a connection from the ship's fire main by means of a lockable screw-down non-return valve which will prevent a backflow from the drenching system to the fire main.

24.18.2 Drenching system in oil recovery ships shall be controlled from the navigation bridge.

24.18.3 The independent power pump shall be capable of delivering quantity of water, at the necessary pressure, sufficient for an average application rate of not less than:

- .1 10 l/min/m² of the area to be protected.

24.19 DRY POWDER SYSTEM

24.19.1 Only dry chemical powder approved by the *Register* for this purpose shall be used in the dry powder fire-extinguishing systems.

24.19.2 The system shall be activated by nitrogen or other inert gas approved by the *Register* for this purpose.

24.19.3 The system shall consist of:

- .1 independent self-contained powder units with dry powder containers, propellant gas cylinders and a distribution manifold;
- .2 extinction posts with monitors and/or hand hose lines;
- .3 pipes and fittings for bringing the system into operation and control and powder supply to the extinction posts.

24.19.4 Provision shall be made for a remote release of the system from each extinction post.

The system shall be brought into operation in not more than 30 s after the opening of the propellant gas cylinder from the remotest extinction post of the powder unit concerned.

24.20 GAS FIRE-EXTINGUISHING SYSTEMS USING MEDIA OTHER THAN CARBON DIOXIDE

24.20.1 General

24.20.1.1 Suppliers for the design and installation of gas fire-extinguishing systems for the protection of machinery spaces and cargo pump-rooms, using extinguishing media other than carbon dioxide are subject to special approval by the *Register*.

24.20.1.2 Gas fire-extinguishing systems for the protection of machinery spaces and cargo pump-rooms, using extinguishing media other than carbon dioxide shall be approved in accordance with a standard acceptable to the *Register* (see 24.5.2.4).

24.20.1.3 All systems shall be designed to allow evacuation of the protected space prior to discharge. Means shall also be provided for giving warning of the release of fire-extinguishing medium into any space in which personnel normally work or to which they have access.

24.20.1.4 Halocarbon agents may be used up to the No Observed Adverse Effect Level (NOAEL) calculated on the net volume of the protected space at the maximum expected ambient temperature without additional safety measures. For determination of the referred NOAEL level see *MSC.1/Circ.1316*.

For halocarbon systems using agent above its NOAEL and inert gas systems means shall be provided to limit the exposure time.

24.20.1.5 In no case shall a halocarbon agent be used at concentrations above the Lowest Observed Adverse Effect Level (LOAEL) nor the Approximate Lethal Concentration (ALC) nor shall an inert gas be used at gas concentrations above 52% calculated on the net volume of the protected space at the maximum expected ambient temperature. For determination of the referred LOAEL level see *MSC.1/Circ.1316*.

24.20.1.6 For system using halocarbon agents, the system shall be designed for a discharge of 95% of the design concentration in not more than 10 s.

For systems using inert gases, the discharge time shall not exceed 120 s for 85% of the design concentration.

24.20.1.7 For cargo pump rooms handling flammable liquids other than oil or petroleum products, the system may be used only if the design concentration for the individual cargo has been established in accordance with the recognized standard (see 24.20.1.2) and is documented in the approval certificate.

24.20.2 Calculation of the supply of extinguishing gas

24.20.2.1 The supply of extinguishing gas shall be calculated based on the net volume of the protected space, at the minimum expected ambient temperature using the design concentration specified in the system's type approval certificate.

24.20.2.2 The design concentration shall be at least 30% above the minimum extinguishing concentration determined by a cup burner test acceptable to the *Register*.

These concentrations shall be verified by full-scale testing.

24.20.2.3 The net volume is that part of the gross volume of the space which is accessible to the free extinguishing gas including the volumes of the bilge and of the casing. Objects that occupy volume in the protected space shall be subtracted from the gross volume. This includes, but is not necessarily limited to:

- internal combustion engines;
- reduction gear;
- boilers;
- heat exchangers;
- tanks and trunks;
- exhaust gas pipes, boilers and silencers.

The volume of free air contained in air receivers located in a protected space shall be added to the net volume unless the discharge from the safety valves is led to the open.

24.20.2.4 In systems with centralised gas storage for the protection of more than one space the quantity of extinguishing gas available need not be more than the largest quantity required for any one space so protected.

24.20.3 Gas containers

24.20.3.1 Containers for the extinguishing gas or a propellant needed for the discharge shall comply in respect of their material, construction, manufacture and testing with the requirements specified in *Rules for the classification of ships, Part 10 - Boilers, Heat Exchangers and Pressure Vessels, Section 6*.

24.20.3.2 The filling ratio shall not exceed that specified in the system's type approval documentation.

24.20.3.3 Means shall be provided for the ship's personnel to safely check the quantity of the fire-extinguishing medium in the containers.

24.20.4 Storage

24.20.4.1 Centralised systems

24.20.4.1.1 Gas containers in centralised systems shall be stored in a storage room complying with the requirements for storage rooms, with the exception that storage temperatures up to 55°C are permitted, unless otherwise specified in the type approval certificate.

24.20.4.2 Modular systems

24.20.4.2.1 All systems covered by this Section may be executed as modular systems with the gas containers, and containers with the propellant if any, permitted to be stored within the protected space providing the requirements specified in 24.20.4.2.2 to .9 are complied with.

24.20.4.2.2 The arrangement of gas containers, electrical circuits and piping essential for the release of any system shall be such that in the event of damage to any one power release line or container valve through mechanical damage, fire or explosion in the protected space i.e. a single fault concept,

at least the amount of gas needed to achieve the minimum extinguishing concentration can still be discharged, having regard to the requirement for uniform distribution of the extinguishing gas throughout the space.

Systems that can not comply with the above, for instance systems using only one bottle located inside the protected space, cannot be accepted. Such systems shall be designed with the bottle(s) located outside the protected space, in a dedicated room.

24.20.4.2.3 Duplicate sources of power located outside the protected space shall be provided for the release of the system and be immediately available, except that for machinery spaces, one of the sources of power may be located inside the protected space.

24.20.4.2.4 Electric power circuits connecting the containers shall be monitored for fault conditions and loss of power. Visual and audible alarms shall be provided to indicate this and located in the control room for the propulsion machinery.

24.20.4.2.5 Pneumatic, electric or hydraulic power circuits connecting the containers shall be duplicated and widely separated. The sources of pneumatic or hydraulic pressure shall be monitored for loss of pressure. Visual and audible alarms shall be provided to indicate this and located in the control room for the propulsion machinery.

24.20.4.2.6 Within the protected space, electrical circuits essential for the release of the system shall be heat-resistant, e.g. mineral-insulated cable or equivalent. Piping systems essential for the release of systems designed to be operated hydraulically or pneumatically shall be of steel.

24.20.4.2.7 Not more than two discharge nozzles shall be fitted to any container.

24.20.4.2.8 The containers shall be monitored for decrease in pressure due to leakage or discharge. Visual and audible alarms in the protected space and on the navigating bridge shall be provided to indicate this.

24.20.4.2.9 Each container shall be fitted with an overpressure release device which under the action of fire causes the contents of the container to be automatically discharged into the protected space.

24.20.5 Piping and nozzles

24.20.5.1 Piping shall be made of weldable steel materials designed according to the working pressure of the system.

24.20.5.2 Wherever possible, pipe connections shall be welded. For detachable pipe joints, flange connections shall be used. For pipes with a nominal inside diameter of less than 50 mm threaded welding sockets may be employed.

24.20.5.3 Piping terminating in cargo pump rooms shall be made of stainless steel or be galvanised.

24.20.5.4 Flexible hoses may be used for the connection of containers to a manifold in centralised systems or to a rigid discharge pipe in modular systems. Hoses shall not be longer than necessary for this purpose and be type approved for the use in the intended installation. Hoses for modular systems shall be flame resistant.

24.20.5.5 Only nozzles approved for use with the system shall be installed. The arrangement of nozzles shall comply

with the parameters specified in the system's type approval certificate, giving due consideration to obstructions. In the vicinity of passages and stairways nozzles shall be arranged such as to avoid personnel being endangered by the discharging gas.

24.20.5.6 The piping system shall be designed to meet the requirements specified in 24.20.1.6.

24.20.6 Release arrangements and alarms

24.20.6.1 The system shall be designed for manually initiated power release only (see 24.20.4.2.3). The controls for the release shall be arranged in lockable cabinets (release stations), the key shall be kept conspicuously next to the release station in a locked case with a glass panel. Separate release stations shall be provided for each space which can be flooded separately. The release stations shall be arranged near to the entrance of the protected space and shall be readily accessible also in case of a fire in the related space. Release stations shall be marked with the name of the space they are serving.

24.20.6.2 Centralised system shall be provided with additional means of releasing the system from the storage room.

24.20.6.3 Mechanical ventilation of the protected space shall be stopped automatically before the discharge of the extinguishing gas.

24.20.6.4 Audible and visual alarms shall be provided in the protected space and additional visual alarms at each access to the space (see 24.20.1.3).

24.20.6.5 The alarm shall be actuated automatically by opening of the release station door. Means shall be provided to safeguard that the discharge of extinguishing gas is not possible before the alarm has been actuated for a period of time necessary to evacuate the space but not less than 20 s.

24.20.6.6 Audible alarms shall be of horn or siren sound and be clearly distinguishable from other audible signals.

24.20.6.7 Electrical alarm systems shall have power supply from the main and emergency source of power.

24.20.6.8 For the use of electrical alarm systems in gas dangerous zones the requirements specified in the *Rules for the classification of ships, Part 12 - Electrical Equipment*, Section 19 shall be complied with.

Where pneumatically operated alarms are used the permanent supply of compressed air shall be safeguarded by suitable arrangements.

24.20.7 Tightness of the protected space

24.20.7.1 Apart from being provided with means of closing all ventilation openings and other openings in the boundaries of the protected space, special consideration shall be given to requirements specified in 24.20.7.2 to .4.

24.20.7.2 A minimum gas holding time of 15 min shall be provided.

24.20.7.3 The release of the system may produce significant over- or underpressurisation in the protected space which may necessitate the provision of suitable pressure equalising arrangements.

24.20.7.4 Escape routes which may be exposed to leakage from the protected space shall not be rendered hazardous during or after the discharge of the extinguishing gas in the event of the fire. Control stations and other locations that require manning during a fire situation shall have provisions to keep HF and HCl below 5 ppm at that location. The concentrations of other products shall be kept below values considered hazardous for the required duration of exposure.

24.20.8 Warning signs and operating instructions

24.20.8.1 Warning signs shall be provided at each access to and within a protected space, as appropriate:

- "WARNING! This space is protected by a fixed gas fire-extinguishing system using. Do not enter when the alarm is actuated!"
- "WARNING! Evacuate immediately upon sounding of the alarm of the gas-fire extinguishing system."

The release stations for cargo pump rooms shall be provided with an additional warning as follows:

- "Release to be operated only in the event of fire in the pump room. Do not use for inerting purposes!"

24.20.8.2 Brief operating instructions shall be posted at the release stations.

24.20.8.3 A comprehensive manual with the description of the system and maintenance instructions shall be provided on the ship (see 15.2.4.6 and 15.2.4.9). The manual shall contain an advice that any modifications to the protected space that alter the net volume of the space will render the approval for the individual installation invalid. In this case amended drawings and calculations shall be submitted to the *Register* for approval.

24.20.8.4 For all ships, the fire-extinguishing system design manual shall address recommended procedures for the control of products of gas decomposition, including HF vapour generated from fluorocarbon extinguishing agents which could impair escape. The performance of fire-extinguishing arrangements on passenger ships shall not present health hazards from decomposed extinguishing gases i.e. the decomposition products shall not be discharged in the vicinity of muster (assembly) stations.

24.20.9 Documents

24.20.9.1 Prior to commencing of the installation the following documents shall be submitted in triplicate to the *Register* for approval:

- .1 arrangement drawing of the protected space showing machinery etc. in the space, and the location of nozzles, containers (modular system only) and release lines as applicable;
- .2 list of volumes deducted from the gross volume;
- .3 calculation of the net volume of the space and required supply of extinguishing gas;
- .4 isometrics and discharge calculations;
- .5 release schematic;
- .6 drawing of the release station and of the arrangement in the ship;

- .7 release instructions for display at the release station;
- .8 drawing of storage room (centralised systems only);
- .9 alarm system schematic;
- .10 parts list;
- .11 shipboard manual.

24.21 FIXED LOCAL APPLICATION FIRE-EXTINGUISHING SYSTEMS

24.21.1 The fixed water-based or equivalent local application fire-extinguishing system shall be of an approved type, see 10.5.6.2.

24.21.2 Any installation of nozzles on board shall reflect the arrangement successfully tested (see *MSC/Circ.1387/Corr.1*). If a specific arrangement of the nozzles is foreseen on board, deviating from the one tested, it can be accepted provided such arrangement additionally passes fire tests based on the accepted scenarios (see *MSC/Circ.1082*).

24.21.3 In the case of periodically unattended machinery spaces, the fire-extinguishing system shall have both automatic and manual release capabilities. In the case of continuously manned machinery spaces, the fire-extinguishing system is only required to have a manual release capability.

24.21.4 The automatic release shall be activated by a detection system capable of reliably identifying the local zones. Consideration shall be given to prevent accidental release.

24.21.5 Fixed local application fire-extinguishing systems shall protect areas such as the following without the necessity of engine shutdown, personnel evacuation, or sealing of the spaces:

- .1 the fire hazard portions of internal combustion machinery or, for ships constructed before 1 July 2014, the fire hazard portions of internal combustion machinery used for the ship's main propulsion and power generation;
- .2 boiler fronts (boiler burner location);
- .3 the fire hazard portions of incinerators;
- .4 purifiers for heated fuel oil; and
- .5 oil fired equipment, such as inert gas generators and thermal oil heaters, if located in machinery spaces above 500 m³.

24.21.6 Activation of any local application system shall give a visual and distinct audible alarm in each protected space, in the engine control room and on the navigation bridge. The alarm shall indicate the specific system and/or zone activated. The system alarm requirements described within this paragraph are in addition to, and not a substitute for, the detection and fire alarm system required elsewhere in this Part of the Rules for the classification of ships.

24.21.7 Means shall be provided for testing the automatic release of the system without delivering water in the protected areas.

24.21.8 The operating and maintenance instructions for the system shall be displayed at each control position (see 15.2.4.6 and 15.2.4.9).

24.22 PRESSURE TESTING OF FIRE-EXTINGUISHING SYSTEMS

24.22.1 Fire-extinguishing systems shall be tested with test pressure in compliance with the Table 24.22-1.

Table 24.22-1

| Item | Systems and assemblies to be tested | Hydraulic test pressure | |
|------|---|-------------------------|--|
| | | in work shop | on board ship |
| 1 | 2 | 3 | 4 |
| 1 | Water and foam fire-extinguishing systems (see also Rules for the classification of ships, Part 8 – Piping, 16): .1 piping; .2 sprinkler system piping. | – | in operation |
| 2 | Dry powder system piping | 1.5 p | 1 p (by air) |
| 3 | Carbon dioxide systems: 3.1 high pressure: .1 piping between cylinders and release valves; .2 distribution piping passing through accommodation spaces; .3 piping between release valves and nozzles. 3.2 low pressure: .1 piping between storage tank and release valves; .2 piping between release valves and nozzles. 3.3 gas fire-extinguishing systems, other than carbon dioxide: .1 piping between storage tank and release valves; .2 piping between release valves and nozzles. .3 piping passing through enclosed spaces other than the protected space; and if passing through accommodation spaces | – | 1.5 p ⁴⁾ 5 MPa 1 MPa 1.5 p ⁴⁾ 1 p (by air) 1.5 p 1.5 p ⁵⁾ 1 Mpa 5 Mpa |
| 4 | Piping and scrubber for inert gas system | – | 1 p (by air) |
| 5 | Halogenated hydrocarbon | – | 1.5 p |

| Item | Systems and assemblies to be tested | Hydraulic test pressure | |
|------|--|---|-----------------------------------|
| | | in work shop | on board ship |
| 1 | 2 | 3 | 4 |
| | systems piping | | |
| 6 | Pressure air piping | 1.5 p | 1 p (by air) |
| 7 | Cylinders, containers and storage tanks .1 operating under pressure, including cylinders without valves; .2 operating without pressure; .3 cylinders with valves. | 1.5 p by filling up to the top of air pipe 1 p (by air) | 1 p (by air) in operation – |
| 8 | Fittings ² | 1.5p, but not less than 0.2 MPa | – |

Notes to Table 24.22-1:

- "p" - maximum working pressure in the system. For the gas fire-extinguishing systems "p" is a design pressure of a cylinder, container or tank, [MPa].
- Fittings in assembly shall be tested for the tightness of closing with a pressure of at least 1.25 p and the valves of carbon dioxide and other gas fire-extinguishing media cylinders with the highest breaking pressure of safety disc.
- The systems shall be tested in assembly on board ship upon completion of all erection work.
- Piping, after being hydraulically tested in workshop with a pressure of 1.5 p, may be tested on board by air pressure of 1 p.
- 1.5 times the max pressure assessed by the discharge calculations.
- In ships of 500 gross tonnage and over the water fire main shall be tested with a pressure of fire pumps and in no case less than 1 MPa.

24.23 WATER-SCREEN SYSTEM

24.23.1 Water supply for the water-screen system required in 9.2.2.1.5 shall be by an independent power pump.

The system shall have a connection from the ship's fire main by means of a lockable screw-down non-return valve which will prevent a backflow from the water-screen system to the fire main.

24.23.2 Water supply for water-screen system, where provided for protection of doors in accordance with requirements of Section 17, may be from the ship's fire main. At the connection a lockable screw-down valve shall be provided and shall be locked in a closed position when the system is not in operation.

24.23.3 The independent power pump and/or ship's water fire main system shall be capable of delivering a quantity of water, at the necessary pressure, sufficient for an application rate of not less than 70 l/min per linear metre of the screen length.

24.23.4 The water screen for the protection of doors shall be provided on the side of greater fire risk.

24.17.5 The system shall be controlled from an easily accessible position which shall not be readily cut off by a fire in the protected space.

25 FIRE-EXTINGUISHING APPLIANCES, SPARE PARTS AND TOOLS

25.1 FIRE-EXTINGUISHING APPLIANCES

25.1.1 Fire-extinguishing appliances on board ships shall be kept in good order and be available for immediate use at all times when at sea or in port (see *MSC.1/Circ.1432, as amended by MSC.1/Circ.1516*).

25.1.2 Depending on the type and size of the ship and category and equipment of the ship's spaces, the ships shall be provided with fire-extinguishing appliances as prescribed in Table 25.1 (see also *MSC.1/Circ.1275 and MSC.1/Circ.1275/Corr.1*).

Where, in the opinion of the *Register*, a fire hazard exists in any machinery space for which no specific provisions for fire-extinguishing appliances are prescribed in Table 25.1 there shall be provided in, or adjacent to, that space such a number of approved portable fire extinguishers or other means of fire extinction as the *Register* may deem sufficient.

See also ANNEX 5 to this Part of the Rules for the classification of ships.

25.1.3 The couplings of all portable fire-extinguishing appliances (fire hoses, foam applicators, extension pipes, etc.) shall be of the standard quick-acting type and size to suite the size of the fire hydrant couplings fitted on board.

All portable fire-extinguishing appliances shall be made of a material resistant to marine environment.

Aluminium alloys may be used for fire hose couplings, foam applicators and extension pipes, except in cargo areas of tankers and combination carriers ($\leq 60^{\circ}\text{C}$).

In tankers and combination carriers ($\leq 60^{\circ}\text{C}$) fire hose nozzles and foam applicators (including couplings) in cargo area shall be of the non-sparking type.

- 25.1.4** Fire hoses shall comply with the following:
- .1 they shall have a length of at least 10 m, but not more than:
 - .1.1 15 m in machinery spaces;
 - .1.2 20 m in other spaces and open decks; and
 - .1.3 25 m for open decks on ships with a maximum breadth in excess of 30 m;
 - .2 they shall be made of non-perishable material approved by the *Register*;
 - .3 each hose shall be provided with a nozzle and the quick acting couplings of an approved type.

- 25.1.5** Fire hose nozzles shall comply with the following:
- .1 standard nozzle sizes shall be 12 mm, 16 mm and 19 mm or as near thereto as possible (see 10.2.3).

Larger diameter nozzles may be provided at the discretion of the *Register*.

- .2 all nozzles shall be of an approved dual-purpose type (i.e., spray/jet type) incorporating a shut-off.
- .3 Fire hose nozzles made of plastic type material, e.g. polycarbonate, are considered acceptable provided capacity and serviceability are documented and the nozzles are found suitable for the marine environment.

25.1.6 Foam applicators shall comply with requirements in 24.4.3.2.

25.1.7 Portable foam applicator units shall be located in conspicuous positions near the fire hydrants.

25.1.8 Portable fire extinguishers on board ships shall be of the approved types and shall comply with a recognized national or international standards (see *A.951(23) and ISO 7165:1999*).

Additionally following shall be complied with:

- .1 Extinguisher shall be designed to be carried and operated by hand and have, in working order, a total mass of not more than 23 kg.
- .2 All extinguishers shall have a fire-extinguishing capability at least equivalent to that of a fluid extinguisher of 9 l charge of an extinguishing medium. Unless expressly provided otherwise, each dry powder or carbon dioxide extinguisher shall have a charge of at least 5 kg and each foam extinguisher shall have a charge of at least 9 l.
- .3 Accommodation spaces, service spaces and control stations shall be provided with extinguishers of appropriate types and in sufficient number to the satisfaction of the *Register*. Ships of 1,000 gross tonnage and upwards shall carry at least five extinguishers. For ships of less than 1,000 gross tonnage but not less than 500 the number of extinguishers shall be not less than three and for ships of less than 500 gross tonnage not less than two.
- .4 One of the portable extinguishers intended for use in any space shall be stowed near the entrance to that space. The remaining extinguishers in the public spaces and workshops shall be located at or near the main entrances and exits.
- .5 Carbon dioxide extinguishers shall not be placed in accommodation spaces. In control stations and other spaces containing electrical or electronic equipment or appliances necessary for the safety of the ship, extinguishers shall be provided whose extinguishing media are neither electrically conductive nor harmful to the equipment and appliances. Extinguishers provided for galleys shall be of the fluid or carbon dioxide type.

- .6 In accommodation spaces part of the extinguishers provided shall be of the fluid type and in the machinery spaces of the foam type.
 - .7 Extinguishers shall be situated ready for use at easily visible places, which can be reached quickly and easily at any time in the event of a fire, and in such a way that their serviceability is not impaired by the weather, vibration or other external factors. All extinguishers shall be provided with devices which indicate whether they have been used.
 - .8 Spare charges shall be provided for 100% of the first ten extinguishers and 50% of the remaining extinguishers capable of being recharged on board. Not more than sixty total spare charges are required. Instructions for recharging shall be carried on board.
 - .9 For extinguishers which cannot be recharged on board, additional extinguishers of the same quantity, type, capacity and number as determined in paragraph .8 shall be provided in lieu of spare charges.
 - .10 In cargo ships of less than 500 gross tonnage, and in passenger ships not intended for international voyages of less than 500 gross tonnage, one additional extinguisher of the same type and capacity, as provided on board, shall be provided as spare.
- 25.1.9** Foam fire extinguishers of at least 45 l capacity and 135 l capacity shall comply with the following:
- .1 they shall be located in the protected space and suitably fixed against rough sea;
 - .2 only fresh water shall be used for charging the fire extinguishers. The air for an air-foam extinguisher shall be kept in a cylinder provided solely for that particular extinguisher. The quantity of air in the cylinder shall be at least 25 per cent in excess of the rated amount. The air cylinder shall be fitted with a pressure gauge;
 - .3 foam shall be delivered through a hose being about 10-15 m in length. In order to increase the range of action for 135 litre fire extinguishers, fixed piping for attachment of hose thereto may be fitted, the total length of pipes and hoses not exceeding 30 m.
In any case, the location of fire extinguishers and the length of pipes and hoses shall be such that the foam may be discharged into any part of the space. For fire extinction under the floor plates or engine bed plates, the openings in the floors to lead a hose through or an appropriate arrangements of fixed branch pipes shall be provided.
- 25.1.10** Carbon dioxide or dry powder fire extinguishers of at least 16 kg capacity and 45 kg capacity shall comply with the following:
- .1 carbon dioxide extinguishers shall not be used in spaces of such volume that the complete discharge of the carbon dioxide contained in the cylinders is liable to cause concentration in excess of 5 per cent;
 - .2 an extinguishing medium shall be discharged to any part of the protected space through flexible hose of 10-15 m in length and, where necessary, through fixed piping;
 - .3 they shall be located in the protected space and suitably fixed against rough sea.
- 25.1.11** Metal receptacles containing sand or dry sawdust impregnated with soda shall comply with the following:
- .1 the capacity of receptacle shall be:
100 l in ships of less than 2,000 gross tonnage;
125 l in ships of 2,000 gross tonnage and upwards;
 - .2 each receptacle shall be provided with a readily opening cover, a suitable shovel for spreading the material and a device for holding the cover in the open position.
- 25.1.12** Fire smothering blankets shall comply with the following:
- .1 they shall be sufficiently stout and durable;
 - .2 they shall be made of fire-proof fabric of thickness not less than 3.5 mm or wire-armoured textile or clean unraised thick felt;
 - .3 they shall be stowed in special readily openable cases or lockers;
 - .4 the blanket dimensions shall be not less than 1.5 m x 2.0 m.
- 25.1.13** Set of fire-fighting tool shall comply with the following:
- .1 one complete set shall include one fire axe and one light-weight fire crowbar;
 - .2 it shall be stowed on regular board and fastened with quick-release straps;
 - .3 in cargo spaces intended for carriage of motor vehicles with fuel in their tanks for their own propulsion one set of fire-fighting tool shall be located at each access to such spaces from accommodation and service spaces.
- 25.1.14** Fire-fighter's outfits shall comply with 10.10 and 24.3.2.1.
For requirements regarding fire-fighter's communication see 10.10.4.
- 25.1.15** Portable electric drill shall be provided with an electric cable of sufficient length. Pneumatic portable drill may be used instead of an electric drill.
- 25.1.16** Portable electric exhaust fans shall be provided with an electric cable and flexible hoses of sufficient length

to ensure the ventilation of any space protected. Ventilation fan for gas-dangerous spaces shall be of non-sparking type.

25.1.17 Portable fire motor-pumps shall comply with the following:

- .1 the minimum capacity of the pump shall be at least 15 m³/h at a pressure head of not less than 0.25 MPa at the pump outlet and suction head of not less than 0.05 MPa. The centrifugal pump shall be of self-priming type;
- .2 the pump motor shall be of diesel type and capable of being readily started at an ambient temperature under or above zero either by hand or by a special starter.
There shall be provided a sufficient quantity of fuel to ensure the operation of pump for at least 1.5 hours without refuelling.
The ship shall carry an additional quantity of fuel for refuelling;
- .3 the pump shall be provided with suction hose of sufficient length fitted with a suction strainer and a nonreturn valve, two delivery hoses, each 12 m long, two dual-purpose fire hose nozzles with an outlet diameter of at least 10 mm and a branch coupling for connecting two fire hoses;
- .4 delivery hoses and nozzles shall be fitted with couplings of the same type and size as those used in the water fire main system.
- .5 the pump-motor shall be provided with tools and accessories as per manufacturer's recommendation.

25.1.18 International shore connection (see Figure 25.1.18-1) shall comply with the following:

- .1 outside diameter of flange: 178 mm;
- .2 inside diameter of flange: 64 mm;
- .3 bolt circle diameter: 132 mm;
- .4 4 holes, 19 mm in diameter, spaced equidistantly and slotted to the flange periphery;
- .5 flange thickness: at least 14.5 mm;
- .6 bolts: 4 pcs, each of 16 mm diameter and 50 mm in length;
- .7 bolt nuts: 4 pcs, each of 16 mm in diameter;
- .8 washers for bolts: 8 pcs.

The international shore connection shall be of steel or other equivalent material and shall be designed for 1.0 MPa services. The flange shall have a flat face on one side and on the other side shall be permanently attached to a coupling that will fit the ship's hydrant and hose. The connection shall be kept on board ship together with a gasket of any material suitable for 1.0 MPa services.

Figure 25.1.18-1

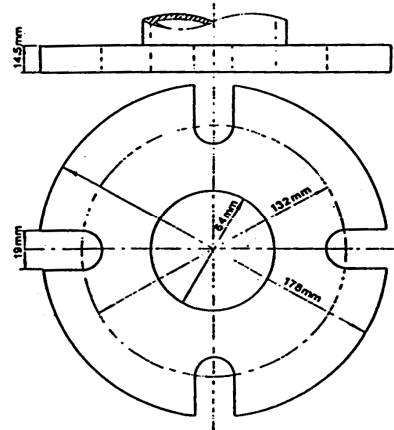

25.1.19 A water fog applicator might consist of a metal L-shaped pipe, the long limb being about 2 m in length, capable of being fitted to a fire hose, and the short limb being about 250 mm in length, fitted with a fixed water fog nozzle or capable of being fitted with a water spray nozzle.

Water fog applicators shall be kept in the vicinity of the hydrants or, if intended for breathing apparatus, near them.

25.1.20 Portable instruments shall be capable of measuring the concentration of flammable and toxic vapour and gases and oxygen in the air, as applicable.

Suitable means shall be provided onboard for the calibration of such instruments.

The ship's crew shall be trained in the use of such instruments.

For tankers see 4.5.7.1 and 4.5.7.2.

25.1.21 Emergency escape breathing devices (EEBDs) shall provide personnel breathing protection against a hazardous atmosphere while escaping to an area of safety. EEBDs shall be in compliance with 24.3.2.2. On all ships EEBDs shall be situated ready for use at easily visible places, which can be reached quickly and easily at any time in the event of fire. For the Guidelines for the performance, location, use and care of EEBDs see *MSC/Circ. 849*.

25.1.22 Fire buckets shall be of about 10 litres capacity and provided with an attached lanyard. Fire buckets shall be stowed on open deck and be easily available during an emergency. They shall be light and easy to handle and shall be painted in red.

Table 25.1

| Item | Type of fire-extinguishing appliances | Quantity of fire-extinguishing appliances to be kept on board |
|------|---|---|
| 1 | 2 | 3 |
| 1. | Fire hoses with couplings (see 25.1.4): .1 for water: .2 for foam: | .1 See 10.2.3. .1 Half the number of foam hydrants, but not less than four, for cargo tank deck area. .2 For other spaces in compliance with the number of foam hydrants fitted. |
| 2. | Fire hose nozzles and foam applicators: .1 dual purpose nozzles for producing a compact and a sprayed water jet (see 25.1.5): .2 foam applicators: .3 extension pipes: | .1 In compliance with the number of fire hoses fitted. .1 Half the number of foam hydrants, but not less than four, for cargo tank deck area; .2 For other spaces in compliance with the number of foam hydrants fitted. .1 In compliance with the number of foam applicators, for cargo tank deck area. |
| 3. | Portable foam applicator units (see 25.1.7): | .1 in passenger ships and cargo ships of 500 gross tonnage and upwards in machinery spaces of category A and boiler rooms: – one unit for each space; .2 in store rooms for fuel oil and work-shops where fuel oil, flammable liquids and combustible materials are used: – one unit for each space; .3 in special category spaces: – at least two units .4 on open deck of container ships: – at least two units. .5 in ro-ro and vehicle spaces intended for the carriage of motor vehicles with fuel in their tanks for their own propulsion: – at least two units. |
| 4. | Portable fire extinguishers using extinguishing medium as follows: water (with or without additives), foam, dry powder/dry chemical (standard, multiple or general purpose), carbon dioxide, wet chemical and clean agents (see 25.1.8). RO may accept use of dry powder fire extinguishers as an equivalent to foam fire extinguishers, provided they use an approved type of dry powder. .1 Control stations: | The minimum number and arrangement of portable fire extinguishers in control stations, accommodation and service spaces, machinery spaces, cargo spaces, weather decks and other spaces on board ships shall be determined on the basis of two fire extinguishers for every 30 m or part thereof of the deck length on which such spaces are located, but not less than the following: .1 one Class A or C extinguisher for every 50 m ² and/or part thereof of the space; one extinguisher may be fitted in the corridor for a group of small spaces with a total area of up to 50 m ² , provided that the entrances to the spaces are adjacent and situated in the same corridor. Not required in unattended spaces in cargo ships of less than 500 gross tonnage; .2 two Class A or C extinguishers for the wheelhouse of 50 m ² and above, otherwise only one; .3 one Class A or C extinguisher for central control station for propulsion machinery and, additionally, one extinguisher, when containing main switchboard, suitable for electric fires; .4 two Class B and/or C extinguishers for space containing an emergency diesel generator. For the space containing diesel – driven power source for the emergency fire pump only one such extinguisher suffice. |

Table 25.1 (continued)

| 1 | 2 | 3 |
|---|--|--|
| | .2 Accommodation and service spaces and galleys: | .1 for every 25 m, or part thereof, of the length of the corridors serving such spaces - one Class A extinguisher; .2 for every 200 m ² , or part thereof, of the public spaces - one Class A extinguisher. For spaces of less than 15 m ² in area - not required; .3 in galleys and bakeries with electrical or gas-fired equipment - one Class B extinguisher and, additionally, one of Class F or K for galleys with deep fat fryers .4 in lockers and store rooms for flammable materials - one Class B extinguisher for each space, or group of small spaces; .5 in other service spaces - one Class A or B extinguisher (if not available in corridor near the entrance to the space). |
| | .3 Machinery spaces: | .1 in machinery spaces of category A containing internal combustion machinery - a sufficient number of Class B extinguishers or equivalent which shall be so located that no point in the space is more than 10 m walking distance from an extinguisher and that there are at least two such extinguishers in each such space; for cargo ships of less than 500 gross tonnage at least one such extinguisher; .2 in machinery spaces of category A containing oil-fired boilers or oil fuel units, in each firing space in each boiler room and in each space in which a part of the oil fuel installation is located - at least two Class B extinguishers. (see item 7. in this table); .3 in separate machinery spaces containing internal combustion machinery of less than 375 kW total power output, used for the purposes other than main propulsion, and/or different auxiliary machinery - at least one Class B extinguisher for every 50 m ² or a part thereof of the space; .4 in separate spaces containing main switchboards - two Class C extinguishers. In spaces having an area of less than 15 m ² one such extinguisher, located near the entrance, suffice; .5 in battery rooms, other than those intended for radio station and emergency services - one Class C extinguisher located at outside of the entrance to the room; .6 in cargo pump-rooms and cargo hose spaces - one Class B extinguisher for every 30 m ² or part thereof, of the floor area. |
| | .4 Other spaces: | .1 in workshops - one Class B extinguisher for every 25 m ² , or part thereof, of the floor area. In welding shops - one Class C extinguisher, in addition; .2 in special category spaces and ro-ro spaces at each deck level - Class B extinguishers shall be provided and spaced not more than 20 m apart on both sides of the space. At least one such extinguisher shall be located at each access to such a space; .3 in cargo spaces intended for the carriage of motor vehicles with fuel in their tanks for their own propulsion - one Class B extinguisher at each entrance to such spaces; .4 for cargo spaces intended for the carriage of dangerous goods see 19.3.7; .5 for platforms for helicopters see 18.5.1. |

Table 25.1 (continued)

| 1 | 2 | 3 |
|-----|--|--|
| 5. | Foam fire extinguishers of at least 45 l capacity or carbon dioxide or equivalent dry powder fire extinguishers of at least 16 kg capacity (see 25.1.9 and 25.1.10): | <p>.1 in machinery spaces of category A containing internal combustion machinery or, in addition, oil fuel units and/or oil-fire boilers and in spaces containing steam turbines or enclosed steam engines with a total aggregate output of not less than 375 kW, in each such space -foam extinguishers sufficient in number to enable foam or its equivalent to be directed onto any part of the fuel and lubricating oil pressure systems, gearing and other fire hazards portions. For spaces containing steam turbines and enclosed steam engines fitted with a fixed fire extinguishing system (see Annex 5, Table 1-1, item 8.) which provides protection equivalent to that required by this subparagraph, such extinguishers need not be provided;</p> <p>.2 in spaces containing electric generators and/or electrical machinery used for main propulsion - at least one such extinguisher for each space.</p> |
| 6. | Foam fire extinguisher of at least 135 l capacity, or carbon dioxide or dry powder fire extinguisher of at least 45 kg capacity (see 25.1.9 and 25.1.10): | <p>.1 in machinery spaces containing oil-fired boilers - not less than one approved foam type extinguisher in each space. In the case of domestic boilers of less than 175 kW such an extinguisher is not required;</p> <p>.2 for landing deck for helicopters see 18.5.1.</p> |
| 7. | Metal receptacles containing sand or sawdust impregnated with soda (see 25.1.11): | <p>.1 in each firing space in each boiler room and in each space in which a part of the oil fuel installation is situated - one metal receptacle. An approved portable Class B extinguisher may be substituted as an alternative.</p> |
| 8. | Fire smothering blankets (see 25.1.12): | <p>.1 one blanket for every 40 m, or a part thereof, of cargo deck length in oil tankers and weather deck length in passenger ships;</p> <p>.2 in all other ships - two blankets for ships of 1,000 gross tonnage and upwards; - not less than one blanket for ships of less than 1,000 gross tonnage;</p> <p>.3 in machinery spaces of category A in ships of 300 gross tonnage and upwards - one blanket for each space;</p> <p>.4 in workshops - one blanket for each space.</p> |
| 9. | Sets of fire-fighting tools (see 25.1.13): | <p>.1 in ships of less than 2,000 gross tonnage - at least one set;</p> <p>.2 in ships of 2,000 gross tonnage and upwards, but less than 4,000 - at least two sets;</p> <p>.3 in ships of 4,000 gross tonnage and upwards, but less than 10,000 - at least three sets;</p> <p>.4 in ships of 10,000 gross tonnage and upwards - at least four sets.</p> |
| 10. | Fire-fighter's outfit (see 25.1.14): | <p>.1 in passenger ships - see 10.10.2.1 and 10.10.2.2.</p> <p>.2 in cargo ships - two outfits (see 10.10.2.1). In ships of less than 500 gross tonnage - one outfit;</p> <p>.3 in tankers and combination carriers ($\leq 600\text{C}$) and tankers ($> 600\text{C}$) of 500 gross tonnage and upwards - four outfits. In ships of less than 500 gross tonnage - two outfits.</p> <p>.4 The Register may require additional fire-fighter's outfits and sets of personal equipment, having due regard to the size and type of the ship.</p> <p>.5 Existing ships shall be fitted with additional self-contained breathing apparatus to replace, or make redundant, existing smoke helmet type breathing apparatus where these form part of the minimum equipment required (see <i>MSC/Circ. 1085</i>).</p> |

Table 25.1 (continued)

| 1 | 2 | 3 |
|-----|--|---|
| 11. | Portable electric or pneumatic drill (see 25.1.15): | .1 in all ships of 1,000 gross tonnage and upwards - at least one drill. |
| 12. | Portable exhaust fan, complete with suction and discharge hoses (see 25.1.16): | .1 in all ships of 500 gross tonnage and upwards, where machinery spaces of category A are provided with fixed gas fire-extinguishing systems and are not otherwise equipped with efficient ventilation system necessary for the purpose of gas freeing - at least one fan; .2 in other ships, where it is found necessary by the <i>Register</i> - one fan. |
| 13. | Portable fire motor pump with suction and discharge hoses (see 25.1.17): | .1 in ships not provided with fixed emergency fire pump - at least one set. |
| 14. | International shore connection (see 25.1.18): | .1 in ships of 500 gross tonnage and upwards - at least one set. |
| 15. | Portable instruments for measuring the concentration of (see 25.1.20): .1 flammable and toxic vapours and gases (as appropriate for the cargoes being carried): | .1 in ships carrying solid dangerous goods in bulk and MHB goods (where required by IMSBC Code) - at least two instruments; .2 in ro-ro ships and ships carrying motor vehicles with fuel in their tanks for their own propulsion - at least one instrument; .3 in tankers and combination carriers ($\leq 60^{\circ}\text{C}$) - at least two instruments. In ships of less than 5,000 tdw but not less than 600 tdw - at least one instrument; .4 in oil recovery ships - at least one instrument. |
| | .2 oxygen: | .1 in tankers and combination carriers ($\leq 60^{\circ}\text{C}$) - at least two instruments. In ships of less than 5,000 tdw but not less than 600 tdw - at least one instrument; .2 in ships carrying solid dangerous goods in bulk and MHB goods (where required by IMSBC Code), - at least one instrument; .3 in ro-ro ships and ships carrying motor vehicles with fuel in their tanks for their own propulsion - at least one instrument. |
| 16. | Water fog applicators (see 25.1.19): | .1 in passenger ships carrying more than 36 passengers: in each machinery space of category A - at least two applicators; and for each pair of breathing apparatus (see 10.10.2.2.2) - at least one applicator; .2 in each special category space - at least three applicators; .3 in ro-ro and vehicle spaces intended for the carriage of motor vehicles with fuel in their tanks for their own propulsion - at least three applicators. |
| 17. | Two-way portable VHF radiotelephone apparatus: | in passenger ships - two two-way portable radiotelephone apparatus for each fire party for fire-fighter's communication shall be carried on board (see 10.10.4), and - one two-way portable radiotelephone apparatus for each member of the fire patrol (see 7.8.3). |

Table 25.1 (continued)

| 1 | 2 | 3 |
|-----|---|---|
| 18. | Emergency escape breathing devices - EEBDs (see 25.1.21 and <i>MSC/Circ.1081</i>): | <p>In passenger ships and in cargo ships of 500 gross tonnage and upwards:</p> <p>.1 within accommodation spaces See 13.3.4. If not required differently elsewhere in this Part of the Rules for the classification of ships, number of EEBDs could in no case be less than three (one of them being considered as spare).</p> <p>.2 within machinery spaces of category A containing internal combustion machinery used for main propulsion where crew are normally employed or may be present on a routine basis (see 13.4.3) - one EEBD in the engine control room, if located within the machinery space; - one EEBD in workshop areas. If there is, however, a direct access to an escape way from the workshop, an EEBD is not required; and - one EEBD on each deck or platform level near the escape ladder constituting the second means of escape from the machinery space (the other means being an enclosed escape trunk or watertight door at the lower level of the space). Different number or location may be required by the <i>Register</i> taking into consideration the layout and the dimensions and/or the normal manning of the space.</p> <p>.3 For machinery spaces of category A other than those containing internal combustion machinery used for main propulsion - in any case, not less than one EEBD on each deck or platform level near the escape ladder constituting the second means of escape from the space (the other means being an enclosed escape trunk or watertight door at the lower level of the space).</p> <p>.4 For other machinery spaces (not being of category A) - the number and location of EEBDs shall be subject to special consideration by the <i>Register</i> in each particular case.</p> |
| 19. | Fire buckets (see 25.1.22): | <p>.1 in ships having no water fire main system - at least three buckets;</p> <p>.2 in ships not provided with emergency fire pump - at least three buckets.</p> |

25.2 SPARE PARTS AND TOOLS

25.2.1 All ships shall carry spare parts and tools.

For passenger ships of 300 gross tonnage and upwards, other than ships of restricted service, and for cargo ships of 500 gross tonnage and upwards it is recommended to carry component spares and tools for fixed fire detection and fire-extinguishing systems fitted on board, the number of which should be not less than that specified in the Table 25.2.

In all other ships provision should be made for spare parts and tools specified in Table 25.2, items 1.1, 1.2, 1.3, 1.5, 1.6, 9.1 and 9.2.

25.2.2 The spare parts and tools for fire detection and fire extinguishing systems shall be kept in the fire control stations. The spare parts and tools for pumps, compressors and motors, etc., shall be kept in the vicinity of the relevant machinery.

25.2.3 Spare parts shall be suitably marked.

Table 25.2

| Item | Description of spares and tools | Number per ship |
|---|---|--|
| 1 | 2 | 3 |
| 1 | Water fire main system: | |
| | .1 a fire hoses of each length and diameter fitted complete with couplings | 1 pc of each size |
| | .2 reduction couplings of each size fitted (if the ship is provided with hydrants of various diameters) | 2 pcs |
| | .3 quick-acting hose couplings | 2 pcs (of each diameter) In ships of gross tonnage of 4000 and upwards 4 pcs (of each diameter fitted) |
| | .4 rubber ring packings for couplings, nozzles, fire-extinguishers, etc. | 5 per cent of the total number fitted, but not less than 10 pcs |
| | .5 hose clamps | 4 pcs (for ships of gross tonnage less than 300 1 pc for each hose but not more than 4) |
| | .6 coupling wrenches (where nozzles are fitted by means of a special wrench) | 2 pcs(of each diameter) |
| | .7 fire hydrants | 1 pc of each size |
| | .8 fire hydrant handwheel | 1 pc of each size fitted |
| .9 valve disks with packing rings for fire hydrants | 1 pc of each size fitted | |

Table 25.2 (continued)

| | | |
|---|---|---|
| 2 | Sprinkler system: | |
| | .1 sprinkler heads, assembly | 6 pcs |
| | .2 wrenches for sprinkler heads (where heads are fitted by means of a special wrench) | 1 pc for each section |
| 3 | .3 control panel and indicating units components | 1 set, as per manufacturer's recommendation |
| | Pressure water-spraying, water screen and drenching systems: | |
| 3 | .1 spray nozzles of various types and sizes fitted in each system | 5 per cent of total number of spray nozzles fitted (of each type) |
| | .2 wrench for spray nozzles (where nozzles are fitted by means of a special wrench) | 1 pc of each size |
| 4 | Foam fire extinguishing system: | |
| | .1 foam hydrants | 1 pc of each size |
| | .2 foam applicators | 1pc |
| | .3 gauge glasses for storage tank | 1pc of each size |
| 4 | .4 rubber ring packings | One set including 1pc of each size fitted |
| 5 | Carbon dioxide systems: | |
| | .1 cylinder valves, assembly | 1 pc |
| | -for up to 50 cylinders fitted | 2 pcs |
| | -for up to 100 cylinders fitted | 3 pcs |
| | -for more than 100 cylinders fitted | |
| | .2 wrenches for cylinder valves and other fittings | 1 set for each storage room |
| | .3 plugs for closing pipes leading from cylinder valves, when cylinders are removed | 25 per cent of the number of cylinders |
| .4 safety rupture discs | In accordance with the number of cylinders | |
| .5 thrust bushes and washers for safety devices | 10 per cent of the number of cylinders | |
| .6 protective caps for cylinder valves | In accordance with the number of cylinders | |
| .7 non return valves | 5% of the total number fitted | |

Table 25.2 (continued)

| Item | Description of spares and tools | Number per ship |
|------|---|---|
| 1 | 2 | 3 |
| | .8 discharge nozzles of each type and size | 2 pcs |
| | .9 scale for weighing cylinders or carbon dioxide level gauge | 1 pc |
| 6 | Inert gas system: | |
| | .1 control (sluice) valve for discharge of inert gas into the protected space | 1 pc |
| | .2 components for automatic control | 1 set, as per manufacturers recommendation |
| 7 | Halon systems: | |
| | .1 spray nozzles of each type and size fitted | 1-2 pcs |
| | .2 wrenches for spray nozzles | 1 pc(of each size) |
| | .3 components for safety and pressure reducing valves (springs, disks, packings etc.) | 1 set |
| | .4 level gauge or gauge glass for halon storage tank | 1 set |
| | .5 halon 1301 containers, assembly | 1 pc for each ten containers, spare parts specified in 7.1, 7.2, 7.3 and 7.4 being not required |
| 8 | Dry powder system: | |
| | .1 release arrangement components for hand hose lines and monitors | 1 set of each type |
| | .2 nozzles of each type and size | 1 pc |
| | .3 wrenches for valves, hand hose lines and nozzles and similar | 1 set |
| 9 | Various components for all systems: | |
| | .1 instruments and gauges (pressure and vacuum gauges, thermometers, etc.) | 1 pc of each type and size |
| | .2 relevant packing material | 1 set |
| | .3 fuses for automatic closing of fire doors and fire dampers | In accordance with the number of doors and dampers thus controlled |
| | .4 spare parts for pumps, fans, compressors and motors/engines serving fire-extinguishing systems | See Rules for the classification of ships, Part 7 - Machinery Installation, 5 |

Table 25.2 (continued)

| Item | Description of spares and tools | Number per ship |
|------|--|---|
| 1 | 2 | 3 |
| | .5 tools and components for remote control devices | In accordance with manufacturer's recommendation and as approved by the Register |
| | .6 tools and components for fire detection and fire alarm system | In accordance with manufacturer's recommendation and as approved by the Register |
| | .7 flame arresters (inserts) of each type and size fitted | 1 set |
| | .8 spare parts for electric components of fire extinguishing systems | In accordance with requirements as specified in the Rules for the classification of ships, Part 12 - Electrical Equipment, 21 |

ANNEX 1 MATERIALS USED IN ACCOMMODATION SPACES MSC/CIRC. 1120

Table 1 – Passenger ships

| Materials used in accommodation spaces as defined in regulations II-2/5.3 and 6.2 | | | | | | |
|---|---|--|------------------------------|--------------------------------|--|---|
| Requirements for components in SOLAS Chapter II-2 | | | | | | |
| Components | | Non-combustible material (5.3.1.1) (5.3.1.2.1) | Calorific value (5.3.2.2) | Equivalent volume (5.3.2.3) | Low flame spread (5.3.2.4)* | Smoke production, toxic products (6.2) |
| | | (A) | (B) | (C) | (D) | (E) |
| 1 | moulding | | | X | | |
| 2 | wall panel (lining) | X | | | | |
| 3 | grounds and supports | X | | | | |
| 4 | draft stops | X | | | | |
| 5 | insulation | X | | | | |
| 6 | insulation surface** | | | | X (5.3.2.4.1.2) | |
| 7 | decoration | | | X | | |
| 8 | painted surface** or fabric or veneer** | | -- X | | X (5.3.2.4.1.2) X (5.3.2.4.1.2) | |
| 9 | painted surface or fabric or veneer | | -- X | X X | X (5.3.2.4.1.1) X (5.3.2.4.1.1) | X X |
| 10 | skirting board | | | X | | |

Notes:

* Exposed surfaces of corridors and stairway enclosures referred to in regulation II-2/5.3.2.4.1.1 include floor coverings.

** Where the wall panel is an integral part of the fire insulation in accordance with regulation II-2/9.2.2.3.3, these components shall be of non-combustible material.

Table 2 – Cargo ships / Method IC

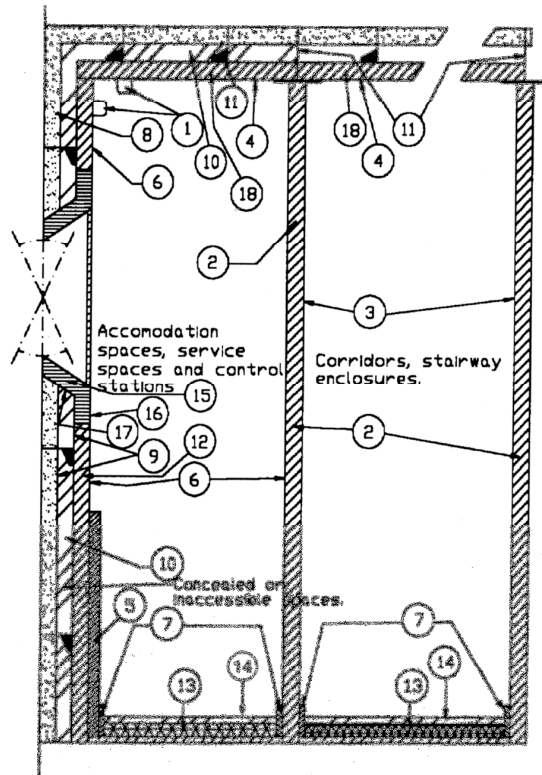

| Components | | Requirements for components in SOLAS Ch.II-2 | | | | | | |
|------------|---|--|------------------------------------|------------------------------|-------------------------------|-------------------------|----------------------|----------------------------|
| | | Non Combustible Material (5.3.1.2.2.1) | Non Combustible Material (5.3.1.1) | Low flame spread (5.3.2.4.2) | Equivalent Volume (5.3.2.3.1) | Caloric value (5.3.2.2) | Smoke production (6) | Not readily ignite (4.4.4) |
| | | (A) | (B) | (C) | (D) | (E) | (F) | (G) |
| 1 | Moulding | | | | X | | | |
| 2 | Panel | X | | | | | | |
| 3 | Painted surfaces or Veneer or Fabric or Foils | | | X | X | X | X ⁽²⁾ | |
| 4 | Painted surfaces or Veneer or Fabric or Foils | | | X | X | X | X ⁽²⁾ | |
| 5 | Decorations | | | | X | | X | |
| 6 | Painted surfaces or Veneer or Fabric or Foils | | | | X | X | X ⁽²⁾ | |
| 7 | Skirting board | | | | X | | | |
| 8 | Insulation | | X ⁽¹⁾ | | | | | |
| 9 | Surfaces and paints in concealed or inaccessible spaces | | | X | | | | |
| 10 | Draught stops | X | | | | | | |
| 11 | Grounds and supports | X | | X | | | | |
| 12 | Lining | X | | | | | | |
| 13 | Primary deck covering 1st layer | | | | | | X ⁽⁴⁾ | X |
| 14 | Floor finishing | | | X ⁽³⁾ | | | X | |
| 15 | Window box | X | | | | | | |
| 16 | Window box surface | | | X | X | X | X | |
| 17 | Window box surface in concealed or inaccessible spaces | | | X | | | | |
| 18 | Ceiling panel | X | | | | | | |

(1) Vapour barriers used on pipes for cold systems (see *IACS UI SC102*) may be of combustible materials providing that their surface has low flame spread characteristics (Reg. II-2/5.3.1.1).

(2) Applicable to paints, varnishes and other finishes (Reg. II-2/6.2.1).

(3) Only in corridors and stairway enclosures.

(4) Only in accommodation and service spaces and control stations (6.3.1).

- Regulation II-2/6.2 only applies to accommodation spaces and control stations as well as stairway enclosures (*IACS UI SC127, Rev.2, Corr.1*)

- As far as window boxes construction is concerned, reference is also to be made to *MSC/Circ.917* and *MSC/Circ. 917 Add.1*.

Table 3 – Cargo ships / Methods IIC and IIC

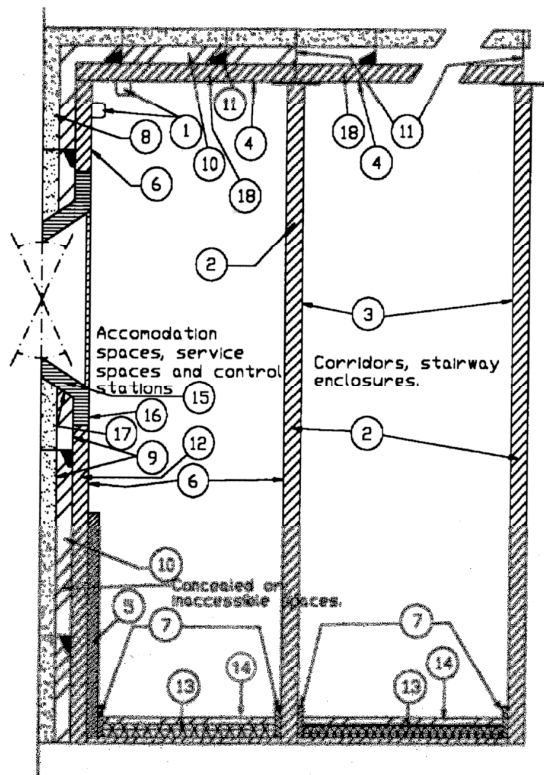

| Components | | Requirements for components in SOLAS Ch.II-2 | | | | | | |
|------------|---|--|------------------------------------|------------------------------|-------------------------------|---------------------------|----------------------|----------------------------|
| | | Non Combustible Material (5.3.1.2.2.1) | Non Combustible Material (5.3.1.1) | Low flame spread (5.3.2.4.2) | Equivalent Volume (5.3.2.3.1) | Calorific value (5.3.2.2) | Smoke production (6) | Not readily ignite (4.4.4) |
| | | (A) | (B) | (C) | (D) | (E) | (F) | (G) |
| 1 | Moulding | | | | X ⁽³⁾ | | | |
| 2 | Panel | X ⁽⁴⁾ | | | | | | |
| 3 | Painted surfaces or Veneer or Fabric or Foils | | | X | X | X | X ⁽⁵⁾ | |
| 4 | Painted surfaces or Veneer or Fabric or Foils | | | X | X ⁽³⁾ | X ⁽²⁾ | X ⁽⁵⁾ | |
| 5 | Decorations | | | | X ⁽³⁾ | | X | |
| 6 | Painted surfaces or Veneer or Fabric or Foils | | | | X ⁽³⁾ | X ⁽²⁾ | X ⁽⁵⁾ | |
| 7 | Skirting board | | | | X ⁽³⁾ | | | |
| 8 | Insulation | | X ⁽¹⁾ | | | | | |
| 9 | Surfaces and paints in concealed or inaccessible spaces | | | X | | | | |
| 10 | Draught stops | X ⁽⁴⁾ | | | | | | |
| 11 | Grounds and supports | X ⁽⁴⁾ | | X | | | | |
| 12 | Lining | X ⁽⁴⁾ | | | | | | |
| 13 | Primary deck covering 1st layer | | | | | | X ⁽⁷⁾ | X |
| 14 | Floor finishing | | | X ⁽⁶⁾ | | | X | |
| 15 | Window box | X ⁽⁴⁾ | | | | | | |
| 16 | Window box surface | | | X ⁽³⁾ | X ⁽³⁾ | X ⁽²⁾ | X | |
| 17 | Window box surface in concealed or inaccessible spaces | | | X | | | | |
| 18 | Ceiling panel | X ⁽⁴⁾ | | | | | | |

(1) Vapour barriers used on pipes for cold systems (see *IACS UI SC102*) may be of combustible materials providing that their surface has low flame spread characteristics (Reg. II-2/5.3.1.1).

(2) Where fire material is fitted on non-combustible bulkheads, ceiling and lining in accommodation and service spaces (Reg. II-2/5.3.2.2).

(3) To be applied to those accommodation and service spaces bounded by non-combustible bulkheads, ceiling and lining (Reg. II-2/5.3.2.3.1).

(4) Only in corridor and stairway enclosures serving accommodation and service spaces and control stations (Reg. II-2/5.3.1.2.2.2).

(5) Applicable to paints, varnishes and other finishes (Reg. II-2/6.2.1).

(6) Only in corridors and stairway enclosures.

(7) Only in accommodation and service spaces and control stations (6.3.1).

- Regulation II-2/6.2 only applies to accommodation spaces, service spaces and control stations as well as stairway enclosures (*IACS UI SC127, Rev2., Corr.1*).

- As far as window boxes construction is concerned, reference is also to be made to *MSC/Circ.917* and *MSC/Circ. 917 Add.1*.

ANNEX 2 PETROLEUM PRODUCTS SUITABLE FOR CARRIAGE IN TANKERS (≤ 60°C)

1 Petroleum products suitable for carriage in Tankers (≤ 60°C) are listed in Table 1-1¹.

Table 1-1

| ASPHALT SOLUTIONS | |
|--------------------------|--------------------------------------|
| 1 | Blending Stocks |
| 2 | Roofers Flux |
| 3 | Straight Run Residue |
| OILS | |
| 1 | Clarified |
| 2 | Crude Oil |
| 3 | Mixtures containing crude oil |
| 4 | Diesel Oil |
| 5 | Fuel Oil No.4 |
| 6 | Fuel Oil No.5 |
| 7 | Fuel Oil No.6 |
| 8 | Residual Fuel Oil |
| 9 | Road Oil |
| 10 | Transformer Oil |
| 11 | Aromatic Oil |
| 12 | Lubricating Oils and Blending Stocks |
| 13 | Mineral Oil |
| 14 | Motor Oil |
| 15 | Penetrating Oil |
| 16 | Spindle Oil |
| 17 | Turbine Oil |
| DISTILLATES | |
| 1 | Straight Run |
| 2 | Flashed Feed Stocks |
| GAS OIL | |
| 1 | Cracked |
| GASOLINE BLENDING STOCKS | |
| 1 | Alkylates - fuel |
| 2 | Reformates |
| 3 | Polymer-fuel |

Table 1-1 (continuation)

| GASOLINES | |
|-----------------------|--------------------------|
| 1 | Casinghead (natural) |
| 2 | Automotive |
| 3 | Aviation |
| 4 | Straight Run |
| 5 | Fuel Oil No.1 (Kerosene) |
| 6 | Fuel Oil No.1-D |
| 7 | Fuel Oil No.2 |
| 8 | Fuel Oil No.2-D |
| JET FUELS | |
| 1 | JP-1 (Kerosene) |
| 2 | JP-3 |
| 3 | JP-4 |
| 4 | JP-5 (Kerosene, heavy) |
| 5 | Turbo Fuel |
| 6 | Kerosene |
| 7 | Mineral Spirit |
| NAPHTHA ⁴ | |
| 1 | Solvent |
| 2 | Petroleum |
| 3 | Heartcut Distillate Oil |
| GTL OILS ² | |
| 1 | Naptha |
| 2 | Kerosene |
| 3 | Diesel oil |
| 4 | Lubricating oils |

Notes to Table 1-1:

1. Special consideration shall be given to the carriage of petroleum products not included in this list.
2. For the petroleum natural gas derived Gas to Liquids (GTL) oils see *BLG.1/Circ. 23*.
3. For list of other products (other than oil products) which may be carried in ships type Tanker (≤ 60°C) see the *Rules for the classification of ships, Part 27 – Chemical Tankers*, Section 18.
4. For Coal tar naphtha solvent and Naphthalene (molten) see the *Rules for the classification of ships, Part 27 – Chemical Tankers*, Section 17.

ANNEX 3 LIQUID CARGOES (> 60°C)

1 Petroleum products (> 60°C) covered by the requirements of head 9.8 are listed in Table 1-1.

Table 1-1

| ASPHALT SOLUTIONS | |
|-------------------|----------------------|
| 1 | Blending Stocks |
| 2 | Roofers Flux |
| 3 | Straight Run Residue |
| OIL | |
| 1 | Diesel Oil |
| 2 | Fuel Oil No. 4 |
| 3 | Fuel Oil No. 5 |
| 4 | Fuel Oil No. 6 |
| 5 | Residual Fuel Oil |
| 6 | Road Oil |
| 7 | Transformer Oil |

| 8 | Aromatic Oil |
|----------|--------------------------------------|
| 9 | Lubricating Oils and Blending Stocks |
| 10 | Motor Oil |
| 11 | Turbine Oil, cracked |
| GAS OIL | |
| 1 | Gas Oil, cracked |
| GTL OILS | |
| 1 | Diesel oil |
| 2 | Lubricating oil |

Note to Table 1-1:

1. List of petroleum products (> 60°C) in Table 1-1 is not meant to be comprehensive and may be amended.
2. For the petroleum natural gas derived Gas to Liquids (GTL) oils see *BLG.1/Circ. 23*.
3. For other liquids products having a fire hazard similar to fire hazard of petroleum products (> 60°C) see *Rules for the classification of ships, Part 27 – Chemical Tankers*, Section 18.

ANNEX 4 NON COMBUSTIBLE AND LOW FIRE RISK CARGOES / CARGOES FOR WHICH A FIXED GAS FIRE-EXTINGUISHING SYSTEM IS INEFFECTIVE (SOLAS REGULATION II-2/10.7.1 AND 10.7.2)

1 Solid bulk cargoes and other cargoes which are non-combustible or constitute a low fire risk and for which a fixed gas fire-extinguishing system may be exempted are listed in Table 1-1 (see *MSC.1/Circ.1395/Rev.6*).

Table 1-1

| Item | Name/Description of cargo | IMO class |
|----------|--|-----------|
| 1 | Cargoes including, but not limited to, those listed in regulation II-2/10: | |
| | Ore | |
| | Coal (Coal and Brown Coal Briquettes) | MHB |
| | Grain | |
| | Unseasoned timber | |
| 2 | Cargoes listed in the IMSBC Code, which are not combustible or constitute a low fire risk: | |
| 2.1 | All cargoes not categorized into group B in the IMSBC Code; | |
| 2.2 | The following cargoes categorized into group B in the IMSBC Code: | |
| | ALUMINA HYDRATE | MHB |
| | ALUMINIUM SMELTING BY-PRODUCTS, UN 3170 (Both the names ALUMINIUM SMELTING BY-PRODUCTS or ALUMINIUM REMELTING BY-PRODUCTS are in use as proper shipping name) | 4.3 |
| | ALUMINIUM FERROSILICON POWDER, UN 1395 | 4.3 |
| | ALUMINIUM SILICON POWDER, UNCOATED, UN 1398 | 4.3 |
| | AMORPHOUS SODIUM SILICATE LUMPS | MHB(CR) |
| | BORIC ACID | MHB(TX) |
| | CLINKER ASH | MHB |
| | COAL TAR PITCH | MHB |
| | DIRECT REDUCED IRON (A) Briquettes, hot moulded | MHB |
| | ELECTRIC ARC FURNACE DUST, PELLETIZED | |
| | FERROPHOSPHORUS (including briquettes) | MHB |
| | FERROSILICON UN 1408, with 30% or more but less than 90% silicon (including briquettes) | 4.3 |
| | FERROSILICON, with at least 25% but less than 30% silicon, or 90% or more silicon | MHB |
| | FLUE DUST, CONTAINING LEAD AND ZINC | |
| | FLUORSPAR (calcium fluoride) | MHB |
| | GRANULATED NICKEL MATTE (LESS THAN 2% MOISTURE CONTENT) | MHB |
| | LEACH RESIDUE CONTAINING LEAD | MHB |
| | LIME (UNSLAKED) | MHB |
| | LOGS | MHB |
| | MAGNESIA (UNSLAKED) | MHB |
| | MATTE CONTAINING COPPER AND LEAD | |
| | MONOCALCIUMPHOSPHATE (MCP) | |
| | MONOAMMONIUMPHOSPHATE (M.A.P.), MINERAL ENRICHED COATINGS | |
| | PEAT MOSS | MHB |
| | PETROLEUM COKE ¹ (calcined or uncalcined) | MHB |
| | PITCH PRILL | MHB |
| | PULP WOOD | MHB |
| | PYRITES, CALCINED (calcined pyrites) | |

| Item | Name/Description of cargo | IMO class |
|----------|--|-----------|
| | RADIOACTIVE MATERIAL, LOW SPECIFIC ACTIVITY (LSA-1), non fissile or fissile – excepted UN 2912 | 7 |
| | RADIOACTIVE MATERIAL, SURFACE CONTAMINATED OBJECTS (SCO-I), non fissile or fissile – excepted UN 2913 | 7 |
| | ROUNDWOOD | MHB |
| | SAND, MINERAL CONCENTRATE, RADIOACTIVE MATERIAL, LOW SPECIFIC ACTIVITY (LSA-I) UN 2912 | |
| | SAW LOGS | MHB |
| | SILICOMANGANESE (low carbon) | MHB |
| | SULPHUR, UN 1350 (crushed lump and coarse grained) | 4.1 |
| | SUPERPHOSPHATE (triple, granular) | MHB |
| | TIMBER | MHB |
| | VANADIUM ORE | MHB |
| | WOODCHIPS, with moisture content of 15% or more | MHB |
| | WOOD PELLETS NOT CONTAINING ANY ADDITIVES AND/OR BINDERS | MHB(OH) |
| | ZINC ASHES, UN 1435 | 4.3 |
| | ZINC OXIDE ENRICHED FLUE DUST | |
| 2.3 | Cargoes assigned to the following generic Group B shipping schedules when they do not exhibit any self-heating, flammability, or water-reactive flammability hazards in accordance with the MHB tests and classification criteria contained in the Code: | |
| | METAL SULPHIDE CONCENTRATES | |
| | METAL SULPHIDE CONCENTRATES, CORROSIVE UN 1759 | |
| 3 | Solid bulk cargoes which are not listed in the IMSBC Code, provided that: | |
| 3.1 | they are assessed in accordance with section 1.3 of the Code; | |
| 3.2 | they do not present hazards of Group B as defined in the Code; and | |
| 3.3 | a certificate has been provided by the competent authority of the port of loading to the master in accordance with 1.3.2 of the Code. | |

Notes to Table 1-1:

- .1 When loaded and transported under the provisions of the IMSBC Code.
- .2 Generally, *Register* may impose any additional conditions when granting such exemptions under the provisions of SOLAS regulation II-2/10.7.1.4 of SOLAS regulation II-2/10.7.1.4

2 Solid bulk cargoes for which a fixed gas fire-extinguishing system is ineffective and for which a fire-extinguishing system giving equivalent protection shall be available are listed in Table 2-1 (see *MSC.1/Circ. 1395/Rev.6*).

Table 2-1

| Item | Name/Description of cargo | IMO class |
|----------|---|-----------|
| 1 | The following cargoes categorized into group B of the IMSBC Code | |
| | ALUMINIUM NITRATE, UN 1438 | 5.1 |
| | AMMONIUM NITRATE, UN 1942 (with not more than 0.2% total combustible material, including any organic substance, calculated as carbon to the exclusion of any other added substance) | 5.1 |
| | AMMONIUM NITRATE BASED FERTILIZER | MHB |
| | AMMONIUM NITRATE BASED FERTILIZER, UN 2067 | 5.1 |
| | AMMONIUM NITRATE BASED FERTILIZER, UN 2071 | 9 |
| | BARIUM NITRATE, UN 1446 | 5.1 |
| | CALCIUM NITRATE, UN 1454 | 5.1 |
| | LEAD NITRATE, UN 1469 | 5.1 |
| | MAGNESIUM NITRATE, UN 1474 | 5.1 |
| | POTASSIUM NITRATE, UN 1486 | 5.1 |
| | SODIUM NITRATE, UN 1498 | 5.1 |
| | SODIUM NITRATE AND POTASSIUM NITRATE, MIXTURE, UN 1499 | 5.1 |

Note to Table 2-1:

1. The *Register* shall take account of the provisions of 19.3.1 when determining suitable requirements for an equivalent fire-extinguishing system.

ANNEX 5

1 FIRE EXTINGUISHING ARRANGEMENTS

1.1 Fire-extinguishing arrangements shall enable to suppress and swiftly extinguish a fire in the space of origin. For this purpose the fixed fire-extinguishing systems shall be installed (see Section 24), having due regard to the fire growth potential of the protected spaces (for the arrangements of the fire-extinguishing appliances see Section 25).

1.2 In addition to the water fire main system, ships spaces shall be protected by one of the fixed fire-extinguishing systems as indicated in Table 1-1, unless expressly provided otherwise elsewhere in this Part of the Rules for the classification of ships.

The Register may consider the use of other, equivalent, fire-extinguishing systems.

1.3 For the fire-extinguishing arrangements in engines, see the Rules for the classification of ships, Part 9 – Machines, 2.2.

1.4 When fixed pressure waterspraying systems are fitted for protection of vehicle, special category and ro-ro spaces requirements in 20.6.1 shall be applied.

Table 1-1

| Item | Spaces | Fixed fire-extinguishing systems | | | | | | | | |
|------|---|----------------------------------|--------------------------------|---------------------|------------------|----------------|-----------------------|---------|--------------------|-------------------|
| | | Automatic sprinkler system | Pressure-water spraying system | Water screen system | Drenching system | Foam system | Carbon dioxide system | Deleted | Water based system | Dry powder system |
| 1 | 2 | 3 | 4 | 5 | 6 | 7 | 8 | 9 | 10 | 11 |
| 1. | Control stations, 1 | + | | | | | | | | |
| 2. | Accommodation spaces and services spaces, 2 | + | | | | | | | | |
| 3. | Paint lockers and flammable liquid lockers, 13 | | + | | | | + | | | + |
| 4. | Cargo tanks and cargo tanks decks area, 3 | | | | | + | | | | |
| 5. | Cargo spaces other than ro-ro and vehicle spaces, 4, 6, 7 | | + | | | + ⁵ | + ¹² | | | |
| 6. | Ro-ro and vehicle spaces, 6, 7 | | + | + ¹¹ | | + ⁵ | + | | + | |
| 7. | Machinery spaces, 8, 14, 16 | | + | | | + ⁵ | + ¹⁵ | | + | |
| 8. | Periodically unattended machinery spaces containing steam turbines or enclosed steam engines with a total aggregate output of not less than 375 kW, 14 | | + | | | + ⁵ | + ¹⁵ | | + | |
| 9. | Exhaust gas uptakes of internal combustion machinery and exhaust gas boilers, flue gas uptakes of boilers and incinerators and gas turbine re-generators, 9 | | + | | | | + | | | |
| 10. | Ventilation ducts | | + | | | | + | | | |
| 11. | Cargo pump-rooms, 14 | | + | | | + ⁵ | + ¹⁵ | | + | |
| 12. | Superstructure outside walls, 10 | | | | + | | | | | |
| 13. | Special category spaces, 6 | | + | | | | | | + | |
| 14. | Cargo area in liquefied gas carriers, cargo piping and cargo manifold | | | | | | | | | + |

| Item | Spaces | Fixed fire-extinguishing systems | | | | | | | | |
|------|-------------------------------------|----------------------------------|--------------------------------|---------------------|------------------|----------------|-----------------------|---------|--------------------|-------------------|
| | | Automatic sprinkler system | Pressure-water spraying system | Water screen system | Drenching system | Foam system | Carbon dioxide system | Deleted | Water based system | Dry powder system |
| 1 | 2 | 3 | 4 | 5 | 6 | 7 | 8 | 9 | 10 | 11 |
| 15. | Incinerator and waste storage rooms | + | + | | | + ⁵ | + ¹⁷ | | + | |
| 16. | Helideck | | | | | + | | | | |

Notes to Table 1-1:

1. Required in:
 - .1 passenger ships carrying more than 36 passengers. Control stations where water may cause damage to essential equipment may be fitted with a fixed fire-extinguishing system of another type, approved by the *Register*;
 - .2 passenger ships carrying not more than 36 passengers, where it is considered necessary by the *Register*.
2. Required in:
 - .1 passenger ships carrying more than 36 passengers;
For the protection of cabin balconies see 10.6.1.3 and 24.7.2.3.
 - .2 passenger ships carrying not more than 36 passengers, unless fixed fire detection and fire alarm system is installed (see 7.5.3);
For the protection of cabin balconies see 10.6.1.3 and 24.7.2.3.
 - .3 cargo ships of 500 gross tonnage and upwards, where method IIC of structural fire protection is adopted.
3. Fixed deck foam system shall be provided in tankers and combination carriers ($\leq 60^\circ\text{C}$) of 500 gross tonnage and upwards, and tankers ($> 60^\circ\text{C}$) of 2,000 gross tonnage and upwards.
4. Not required in:
 - .1 passenger ships of restricted service, where deemed reasonably by the *Register*, and also in ships of less than 1,000 gross tonnage, provided that the ship is fitted with steel hatch covers and effective means of closing all ventilators and other openings leading to the cargo spaces (see 19.2.3);
 - .2 cargo ships of less than 2,000 gross tonnage (see 19.2.3).
 - .3 cargo spaces of any cargo ship if constructed, and solely intended, for the carriage of ore, coal, grain, unseasoned timber non-combustible cargoes or cargoes which, in the opinion of the *Register*, constitute a low fire risk, provided that the ship is fitted with steel hatch covers and effective means of closing all ventilators and other openings leading to the cargo spaces (see Annex 4).
 - .4 For self-heating solid bulk cargoes see *MSC.1/Circ.1456, item 5*.
5. Only high-expansion foam system may be fitted.
For cargo spaces such system shall provide protection equivalent to those of the carbon dioxide system.
High-expansion foam systems using inside air, which gives equivalent protection, for the protection of machinery spaces and cargo pump-rooms shall be approved by the *Register* and comply with guidelines specified in *MSC.1/Circ.1384*.
6. Open spaces and spaces not capable of being sealed shall be fitted with pressure water-spraying system.
High-expansion foam system may not be fitted for container cargo spaces.
Fixed water spraying system shall be provided for open top container cargo spaces in lieu of the fixed gas fire-extinguishing system required (see *MSC/Circ.608 Rev.1*).
Equivalent fixed water-based fire-extinguishing systems (see *MSC/Circ. 1430/Rev.3*), approved by the *Register*, may be accepted in lieu of the fixed pressure-water spraying system required.
For protection of vehicle, special category and ro-ro spaces see also 20.6.1.
7. Water spraying system shall be provided for cooling the cargo spaces intended for the carriage of dangerous goods of class 1, in addition to the fixed gas fire-extinguishing system required (see 19.3.1.3).
8. Required in all passenger ships and cargo ships of 300 gross tonnage and upwards, and applies to:
 - .1 machinery spaces of category A (for incinerator space see item 15.);
 - .2 all spaces in which, subject to special approval by the *Register*, oil fuel having a flash point of less than 60°C (but not less than 43°C) is used;
 - .3 separate rooms where oil fuel purifiers are installed. A fixed fire-extinguishing system capable of being operated from outside the room shall be provided. The system shall be separate for the room, but may be a part of the fixed fire-extinguishing system required for the machinery space.
In passenger ships of 500 gross tonnage and upwards and in cargo ships of 2,000 gross tonnage and upwards machinery spaces of category A above 500 m^3 in volume shall, additionally, be protected by the fixed local application fire-extinguishing system (see 10.5.6).

9. Required in tankers and combination carriers ($\leq 60^{\circ}\text{C}$) and ships serving them, ships intended for the carriage of dangerous goods and oil recovery ships.
10. Required as an alternative to the A-60 class fire insulation (see 9.10.9).
11. In passenger ships designed for special purposes (see 9.2.2.1.5), a water screen system shall be fitted in addition to the fixed fire-extinguishing system required.
12. For list of solid bulk cargoes for which a fixed gas fire-extinguishing system is not effective and for which a fire-extinguishing system giving equivalent protection shall be available see Annex 4, Table 2-1.
13. See 10.6.3.
Flammable liquid lockers intended for stowage of cargo samples, when such spaces are located within the cargo area, need not comply with this requirements.
14. Equivalent water-based fire-extinguishing systems (see *MSC/Circ.1165*, *MSC.1/Circ.1237*, *MSC.1/Circ.1269*, *MSC.1/Circ.1385*, *MSC.1/Circ.1386* and *MSC.1/Circ.1458*; see also *IACS UI SC218, Rev.1* and *IACS UI SC219, Rev.1*), approved by the Register, may be accepted as alternative arrangements for the protection of machinery spaces and cargo pump-rooms.
15. Equivalent fixed gas fire-extinguishing systems (see *MSC/Circ.848*, *MSC.1/Circ.1267*, *MSC.1/Circ.1316* and *MSC.1/Circ.1317*) approved by the Register, may be accepted in lieu of the fixed carbon dioxide system required.
16. Equivalent aerosol fire extinguishing systems (see *MSC.1/Circ.1270* and *MSC.1/Circ.1270/Corr.1*), approved by the Register, may be accepted as alternative arrangements for the protection of machinery spaces.
17. For a waste storage space and combined incinerator and waste storage space an automatic sprinkler system may be used only.
Where an incinerator or waste storage space is located on weather deck it shall be accessible with two means of fire extinguishment: either fire hoses, semi-portable fire extinguishers, one of the fire extinguishing systems specified or combination of any two of these extinguishing devices. A fixed fire-extinguishing system is acceptable as one means of extinguishment.

2 SYSTEMS, APPLIANCES AND EXTINGUISHERS IN MACHINERY SPACES

The unified interpretations of SOLAS Chapter II-2 (see *MSC/Circ. 1120*, *MSC.1/Circ.1436* and *IACS UI SC30 Rev.3*) regarding the number of systems, appliances and extinguishers required by Reg. 10.5.1 and 10.5.2 are shown in Table 2-1.

Table 2-1

| Category A Machinery spaces | System appliances & extinguishers | | | | | | |
|--|-----------------------------------|--|-----------------------------|--|-------------------------|---------------------------------------|--------------------------|
| | Fixed fire extinguishing system | Portable foam applicator* ¹ | Portable foam extinguishers | Additional portable foam extinguishers | 135 l foam extinguisher | 45 l foam extinguishers* ² | Sand boxes* ³ |
| | SOLAS, Ch.II-2, paragraph: | | | | | | |
| | 10.5.1.1, 10.5.2.1 | 10.5.1.2.1, 10.5.2.2.1 | 10.5.1.2.2 | 10.5.2.2.2 | 10.5.1.2.2 | 10.5.2.2.2 | 10.5.1.2.3 |
| Boiler room containing: | | | | | | | |
| Oil-fired boilers | 1 | 1 | 2N | N/A | 1* ⁴ | - | N |
| Oil-fired boilers and oil fuel units | 1 | 1 | 2N + 2 | N/A | 1* ⁴ | - | N |
| Engine room containing: | | | | | | | |
| Oil fuel units only | 1 | - | 2 | N/A | - | - | - |
| Internal combustion machinery | 1 | 1 | X | | - | Y | - |
| Internal combustion machinery and oil fuel units | 1 | 1 | X | | - | Y | - |

| Category A Machinery spaces | System appliances & extinguishers | | | | | | |
|--|-----------------------------------|--|------------------------------------|--|-------------------------|---------------------------------------|--------------------------|
| | Fixed fire extinguishing system | Portable foam applicator* ¹ | Portable foam extinguishers | Additional portable foam extinguishers | 135 l foam extinguisher | 45 l foam extinguishers* ² | Sand boxes* ³ |
| | SOLAS, Ch.II-2, paragraph: | | | | | | |
| | 10.5.1.1, 10.5.2.1 | 10.5.1.2.1, 10.5.2.2.1 | 10.5.1.2.2 | 10.5.2.2.2 | 10.5.1.2.2 | 10.5.2.2.2 | 10.5.1.2.3 |
| Combined engine/boiler room containing: | | | | | | | |
| Internal combustion machinery, oil fired boilers and oil fuel units | 1 | 1 | (2N +2) or X, whichever is greater | 1* ⁴ | Y* ⁵ | N | |
| N = number of firing spaces. N/A =not applicable. "2N" means that two extinguishers are to be located in each firing space. X = sufficient number, minimum two in each space, so located that there are at least one portable fire extinguisher within 10 m walking distance from any point. Y = sufficient number to enable foam to be directed onto any part of the fuel and lubricating oil pressure systems, gearing and other fire hazards. | | | | | | | |

Notes:

- *1. May be located at outside of the entrance to the room.
- *2. May be arranged outside of the space concerned for smaller spaces of cargo ships.
- *3. The amount of sand shall be at least 0.1 m³. A shovel is to be provided. Sand boxes may be substituted by approved portable fire extinguishers.
- *4. Not required for such spaces in cargo ships wherein all boilers contained therein are for domestic services and are less than 175 kW, or boilers are protected by fixed water-based local application fire-extinguishing systems as required by Reg. II-2/10.5.6.
- *5. In case of machinery spaces containing both boilers and internal combustion engines (case not explicitly considered in regulation 10.5) regulation 10.5.1 and 10.5.2 shall apply, with the exception that one of the foam fire-extinguishers of at least 45 l capacity or equivalent (required by regulation 10.5.2.2.2) may be omitted on the condition that the 135 l extinguisher (required by regulation 10.5.1.2.2) can protect efficiently and readily the area covered by 45 l extinguisher.
- *6. Oil fired machinery other than boilers such as fired inert gas generators, incinerators and waste disposal units shall be considered the same as boilers insofar as the required number and type of fire fighting appliances are concerned.

ANNEX 6 FIRE PROTECTION REQUIREMENTS OF INSTALLATION OF BWMS ON- BOARD SHIPS (IACS UR F45)

1 GENERAL

1.1 Application

1.1.1 This Annex details fire safety measures, in addition to that required by this part of the Rules, related to the installation of Ballast Water Management Systems onboard any ship.

This Annex is to be read in conjunction with IACS UR M74, Rev. 2 - Ballast Water Management Systems.

1.1.2 The requirements of this Annex apply for BWMS technologies as listed in Table 1. BWMS with alternative technologies are to be specially considered by the Register.

1.2 Definitions

1.2.1 Airlock

An airlock is a space enclosed by gastight steel bulkheads with two gastight doors spaced not more than 2.5 m apart. The doors shall be self-closing without any holding back arrangements. Air locks shall have mechanical ventilation and shall not be used for other purposes. An audible and visual alarm system to give a warning on both sides of the air lock shall be provided to indicate if more than one door is moved from the closed position. The air lock space shall be monitored for dangerous gas as defined in UR M74 para. 2.3.

1.2.2 Ballast Water Management System (BWMS)

Ballast Water Management System means any system defined in paragraph 2.1 of IACS UR M74, Rev. 2.

Table 1 - Categorization of BWMS technologies

| BWMS's Technology category* → | | 1 | 2 | 3a | 3b | 3c | 4 | 5 | 6 | 7a | 7b | 8 | |
|---|---|--|----------------------|--|--|--|--------------------------------|--------------------------------------|-------------------------------------|---|--|--|---|
| Characteristics ↓ | | In-line UV or UV + Advanced Oxidation Technology (AOT) or UV + TiO2 or UV + Plasma | In-line Flocculation | In-line membrane separation and de-oxygenation (injection of N2 from a N2 Generator) | In-line de-oxygenation (injection of Inert Gas from Inert Gas Generator) | In-tank de-oxygenation with Inert Gas Generator | In-line full flow electrolysis | In-line side stream electrolysis (2) | In-line (stored) chemical injection | In-line side-stream ozone injection without gas/liquid separation tank and without Discharge treatment tank | In-line side-stream ozone injection with gas/liquid separation tank and Discharge water treatment tank | In-tank pasteurization and de-oxygenation with N2 generator | |
| Des-infection when ballasting | Making use of active substance | | X | | | In-tank technology: No treatment when ballasting or de-ballasting | X | X | X | X | X | In-tank technology: No treatment when ballasting or de-ballasting | |
| | Full flow of ballast water is passing through the BWMS | X | X | X | X | | X | | | | X | | |
| After-treatment when de-ballasting | Only a small part of ballast water is passing through the BWMS to generate the active substance | | | | | | | | X | | | | |
| | Full flow of ballast water is passing through the BWMS | X | | | | | | | | | | | X |
| | Injection of neutralizer | | | | | | X | X | X | X | X | | |
| | Not required by the Type Approval Certificate issued by the Administration | | X | X | | | | | | | | | |

| BWMS's Technology category* → | 1 | 2 | 3a | 3b | 3c | 4 | 5 | 6 | 7a | 7b | 8 |
|--|--|----------------------|--|--|---|-----------------------------------|--------------------------------------|-------------------------------------|---|--|---|
| Characteristics ↓ | In-line UV or UV + Advanced Oxidation Technology (AOT) or UV + TiO2 or UV + Plasma | In-line Flocculation | In-line membrane separation and de-oxygenation (injection of N2 from a N2 Generator) | In-line de-oxygenation (injection of Inert Gas from Inert Gas Generator) | In-tank de-oxygenation with Inert Gas Generator | In-line full flow electrolysis | In-line side stream electrolysis (2) | In-line (stored) chemical injection | In-line side-stream ozone injection without gas/liquid separation tank and without Discharge treatment tank | In-line side-stream ozone injection with gas/liquid separation tank and Discharge water treatment tank | In-tank pasteurization and de-oxygenation with N2 generator |
| Examples of dangerous gas as defined in UR M74 para. 2.3 | | (1) | O ₂ N ₂ | CO ₂ CO | | H ₂ Cl ₂ | H ₂ Cl ₂ | (1) | O ₂ O ₃ N ₂ | | O ₂ N ₂ |
| Notes: | (1) To be investigated on a case by case basis based on the result of the IMO (GESAMP) MEPC report for Basic and Final approval in accordance with the G9 Guideline. (2) In-line side stream electrolysis may also be applied in-tank in circulation mode (no treatment when ballasting or de-ballasting) | | | | | | | | | | |
| Footnote: * | Taking into consideration future developments of BWMS technologies, some additional technologies may be considered in this Table 1 by identifying their characteristics in the same manner as for the above BWMS category 1, 2, 3a, 3b, 3c, 4, 5, 6, 7a, 7b and 8. | | | | | | | | | | |

1.2.3 Ballast Water Management Room (BWMR)

A Ballast Water Management Room is any space containing equipment belonging to the Ballast Water Management System. A space containing remote controls for the BWMS or a space dedicated to the storage of liquid or solid chemicals for BWMS need not be considered as a BWMR for the purposes of this Annex.

1.2.4 BWMS storing, introducing or generating chemicals

In general, BWMS storing, introducing or generating chemicals refer to:

- In-line flocculation (category 2 as per Table 1),
- Chemical injection (category 6 as per Table 1) and
- BWMS technologies using neutralizers injection (category 4, 5, 6 and 7 as per Table 1)

BWMS that do not store, introduce or generate toxic or flammable chemicals may be specially considered as detailed in Table below.

Table 2: Requirements that may be reduced for BWMS storing, introducing or generating chemicals depending on the chemicals

| Requirement | Conditions to be met before reducing the requirement |
|-------------------------|---|
| 2.3.4 | The stored chemicals are neither toxic nor flammable |
| 3.1.1 | The BWMS does not use any flammable or toxic chemical substances |
| 3.3.1 | No dangerous gas as defined in UR M74 para. 2.3 will be generated by the BWMS |
| 6.1.1 | No toxic chemical is stored and no toxic gas will be generated by the BWMS |
| 7.1.1 7.1.3 7.1.6 | No toxic chemical is used or will be generated by the BWMS |

The IMO reports issued during the basic and final approval procedures of the BWMS that make use of active substances (G9 Guidelines) and "safety hazard" as listed in Ch. 17 of IMO IBC Code are to be considered for this purpose.

NOTE: Chemicals include additives for BWMS.

2 FIRE CATEGORIZATION

2.1 General

BWMS shall be classified as follows for the purpose of applying the requirements of SOLAS Chapter II-2:

BWMS containing oil-fired inert gas generators (i.e. BWMS category 3b and 3c as per Table 1) shall be treated as machinery spaces of category A

Other BWMS shall be considered as other machinery spaces and shall be categorized, depending on the ship type (10) or (11) according to SOLAS II-2/9.2.2.3 or (7) according to SOLAS II-2/9.2.2.4, II-2/9.2.3 and II-2/9.2.4

2.2 BWMS located in the cargo area of tankers

Notwithstanding the above, where a BWMS is located in the cargo area of a tanker as allowed by UR M74, the BWMS shall be categorized as (8), a cargo pump-room, according to SOLAS II-2/9.2.4.2.2 for determining the extent of fire protection to be provided.

NOTE: The cargo area of a tanker is defined in para 2.2 of UR M74, Rev.2.

2.3 Storage of chemicals

2.3.1 Spaces where the storage of liquid or solid chemicals for BWMS is intended shall be categorized as store-rooms for the purpose of applying the requirements of SOLAS Chapter II-2, i.e.:

On passenger ships carrying more than 36 passengers:

- "Other spaces in which flammable liquids are stowed" as defined in SOLAS II-

2/9.2.2.3.2.2(14), if flammable products are stored

- "Store-rooms, workshops, pantries, etc." as defined in SOLAS II-2/9.2.2.3.2.2(13) otherwise

On other ships:

- "Cargo pump-rooms" as defined in SOLAS II-2/9.2.4.2.2.2(8) if located in the cargo area of a tanker
- "Service spaces (low risk)" as defined in SOLAS II-2/9.2.2.4.2.2(5), SOLAS II-2/9.2.3.3.2.2(5) or II-2/9.2.4.2.2.2(5) if the surface area is less than 4m² and if no flammable products are stored
- "Service spaces (high risk)" as defined in SOLAS II-2/9.2.2.4.2.2(9), SOLAS II-2/9.2.3.3.2.2(9) or II-2/9.2.4.2.2.2(9) otherwise.

NOTE: It is understood that only chemical injection (category 6 as per Table 1), in-line flocculation (category 2 as per Table 1) and technologies using neutralizer injection (category 4, 5, 6 and 7 as per Table 1) will require chemical or additive storage.

2.3.2 Where the storage of chemicals is foreseen in the same room as the ballast water management machinery, this room shall be considered both as a store-room and as a machinery space in line with 2.1.

2.3.3 When the chemical substances are stored inside integral tanks, the ship's shell plating shall not form any boundary of the tank.

2.3.4 Tanks containing chemicals shall be segregated from accommodation, service spaces, control stations, machinery spaces not related to the BWMS and from drinking water and stores for human consumption by means of a cofferdam,

void space, cargo pump-room, empty tank, oil fuel storage tank, BWMR or other similar space. On-deck stowage of permanently attached deck tanks or installation of independent tanks in otherwise empty hold spaces should be considered as satisfying this provision.

3 BWMR LOCATION AND BOUNDARIES

3.1 BWMS using chemical substances

3.1.1 For BWMS storing, introducing or generating chemicals, the BWMR and chemical substance storage rooms are not to be located in the accommodation area. Any ventilation exhaust or other openings from these rooms shall be located not less than 3m from entrances, air inlets and openings to accommodation spaces.

This requirement need not apply in case the BWMS is located in the engine room.

3.2 Ozone-based BWMS

3.2.1 Ozone-based BWMS – i.e. category 7a and 7b - shall be located in dedicated compartment, separated from any other space by gastight boundaries. Access to the BWMR from any other enclosed space shall be through airlock only, except if the only access to that space is from the open deck.

Access to the ozone based BWMR may be provided through the engine room only provided:

- Access from the engine room to the BWMR is through airlock and,
- An alarm repeater is provided in the BWMR, which will repeat any alarm activated in the engine room.

3.2.2 A sign shall be affixed on the door providing personnel with a warning that ozone may be present and with the necessary instructions to be followed before entering the room

3.3 General

3.3.1 BWMR containing equipment for BWMS of the following types shall be equipped with tested gastight and self-closing doors without any holding back arrangements:

- BWMS storing, introducing or generating chemical substances
- De-oxygenation based on inert gas generator
- Electrolysis
- Ozone injection

Doors leading to the open deck need however not to be self-closing.

4 FIRE FIGHTING

4.1 Fixed fire-extinguishing system

4.1.1 Where fitted, fixed fire extinguishing systems shall comply with the relevant provisions of the Fire Safety Systems Code.

4.1.2 Ozone-based BWMS

BWMR containing equipment related to ozone-based BWMS shall be provided with a fixed fire extinguishing system suitable for category A machinery spaces and capable of manual release.

4.1.3 Where a fixed fire-extinguishing system is provided in the BWMR, it should be compatible with the BWMS and the chemical products that are used, produced or stored in the BWMR. Specific attention shall be paid to potential chemical reactions between the fire extinguishing medium and chemical products used for water treatment.

Especially, water-based fire-extinguishing systems should be avoided in case of sulfuric acid storage.

4.1.4 Foam fixed fire-extinguishing system

For all kinds of BWMS, in case a foam fire extinguishing system is installed in the BWMR, its efficiency shall not be impaired by chemicals used by the BWMS where relevant.

4.1.5 Where a fixed fire-extinguishing system is installed in the BWMR, automatic shutdown of the BWMS upon release of the fixed fire extinguishing system shall be arranged. Any need for cooldown necessary for safe shutdown to be considered in the shutdown sequence.

4.1.6 Where BWMS that includes air or O₂ storage is located in a room covered by a fixed gas fire-extinguishing system, air or O₂ storage shall be taken into account for the gas capacity calculation, unless the discharge pipe from safety valves for air or O₂ storage are led directly to outside the room.

4.2 Portable fire-fighting equipment

4.2.1 There shall be at least one portable fire extinguisher that complies with the provisions of the Fire Safety Systems Code and suitable for electrical fires in the BWMR containing UV-type BWMS.

5 FIRE PREVENTION

5.1 Equipment protection

5.1.1 Overcurrent or overvoltage protection is to be installed to protect UV type BWMS.

5.1.2 Electrolysis reactors are to be provided with at least with two independent means of monitoring operation. The monitoring system shall initiate audible and visual alarms and automatic shutdown of the BWMS in the event that an anomaly is detected. Requirements for shutdown arrangement are clarified in UR M74. 3.1.9.

NOTE: If a pressure relief valve is also provided, the vent of this valve is to be led to a safe location on the open deck, as clarified in UR M74. The valve should be positioned to optimally remove gas from the electrolysis reactor.

5.2 Fire detection

5.2.1 A fixed fire detection and fire alarm system complying with the provisions of the Fire Safety Systems Code shall be installed in spaces containing an inert gas generator or an ozone generator.

5.2.2 A section of fire detectors which covers a control station, a service space or an accommodation space is not to include a BWMR containing equipment related to ozone based BWMS.

6 VENTILATION

6.1 Ventilation arrangement

6.1.1 The ventilation systems for BWMR containing BWMS of the following types shall be independent of the ventilation systems serving any other spaces:

- BWMS storing, introducing or generating chemical substances.
- De-oxygenation, including pasteurization and de-oxygenation (category 3 and category 8 as per Table 1)
- Electrolysis
- Ozone injection

6.1.2 The ventilation exhaust for BWMR containing a nitrogen generator shall be located in the lower part of the room in order to efficiently evacuate dangerous gases – as defined in UR M74 para. 2.3 - heavier than air.

6.1.3 The ventilation exhaust for BWMR containing electrolysis systems shall be located so as to be able to efficiently evacuate dangerous gases – as defined in UR M74 para. 2.3 - that could be generated during the electrolysis process. Due regard shall be paid to the expected quantity and density of such gases when designing the ventilation exhaust.

- The part of the ducts located outside of the BWMR shall be made of steel having a thickness of at least 3 mm for ducts with a free cross-sectional area of less than 0.075 m², at least 4 mm for ducts with a free cross-sectional area of between 0.075 m² and 0.45 m², and at least 5 mm for ducts with a free cross-sectional area of over 0.45 m²; and
- The ducts shall be suitably supported and stiffened
- The outside openings of the ducts shall be fitted with protective screens of not more than 13 mm square mesh.

6.1.5 The ventilation system for BWMR containing ozone-based BWMS or ventilation system for hydrogen de gas arrangement as required by UR M74 para. 3.3.1.5 shall be interlocked with the BWMS such that:

- In case of loss of ventilation (primary and secondary), a visual and audible alarm shall be triggered both inside and outside the BWMR and at a place where a responsible member of the crew is on duty. If the ventilation is not restored after a pre-set time, the BWMS shall then be automatically shut down. Any need for cooldown necessary for safe shutdown is to be considered in the shutdown sequence.
- It shall not be possible to start the BWMS without the ventilation running

For ventilation systems serving BWMR and containing or conveying a dangerous gas, relevant requirements in IACS UR M74 para. 3.3 are to be satisfied.

6.2 Ventilation rate

6.2.1 An adequate power ventilation system shall be provided in enclosed BWMR.

6.2.2 The ventilation capacity shall be at least 30 air changes per hour where explosive or toxic gases may be generated during operation of the BWMS. The IMO reports issued during the basic and final approval procedures of the BWMS that make use of active substances (G9 Guidelines) and “safety hazard” as listed in Ch. 17 of IBC code are to be used as references for identifying those cases.

6.2.3 The ventilation capacity may be reduced as follows:

| | |
|--|-------------------------|
| Flocculation-type BWMS | 6 air changes per hour |
| De-oxygenation, incl. pasteurization and de-oxygenation (category 3 and category 8 as per Table 1) | 6 air changes per hour |
| Full flow electrolysis | 6 air changes per hour |
| Side-stream electrolysis | 20 air changes per hour |
| Ozone injection | 20 air changes per hour |
| Chemical injection | 6 air changes per hour |

NOTE: More stringent ventilation capacity requirements may arise from other regulations e.g. IBC Code requirements for spaces located in the cargo area.

7 PERSONAL EQUIPMENT

7.1.1 Suitable protection equipment shall be available onboard for the protection of the crew members who are engaged in the servicing, maintenance and repair of BWMS storing, introducing or generating chemicals, as recommended by the product manufacturers. The protection equipment shall consist of large aprons, special gloves with long sleeves, suitable footwear, coveralls of chemical-resistant materials, and tight fitting goggles or face shields or both. The protective clothing and equipment shall cover all skin so that no part of the body is unprotected. This protection equipment is to be provided separately without taking into account equipment required by other mandatory requirements.

7.1.2 Work clothes and protective equipment shall be kept in easily accessible places and in special lockers. Such equipment shall not be kept within accommodation spaces, with the exception of new, unused equipment and equipment which has not been used since undergoing a thorough cleaning process. Notwithstanding the above, storage rooms for such

equipment within accommodation spaces if adequately segregated from living spaces such as cabins, passageways, dining rooms, bathrooms, etc.

7.1.3 When a BWMS storing, introducing or generating chemicals is installed on board, suitably marked decontamination showers and an eyewash shall be available in a convenient location in close proximity to the BWMS and the chemical store room(s).

7.1.4 An emergency escape breathing apparatus (EEBD) is to be provided in the BWMS. This emergency escape breathing apparatus may be one of the EEBDs provided in accordance with the requirements of SOLAS II-2/13.

An EEBD need not be required for BWMS of category 1 as per Table 1.

7.1.5 A personal ozone detector, calibrated as per the manufacturer's specifications, shall be provided for each person engaged in the servicing, maintenance and repair of BWMS utilizing ozone.

7.1.6 A two-way portable radiotelephone apparatus dedicated for the BWMS service, maintenance and repair shall be provided, in addition to those required by SOLAS for fire-fighting purposes. This two-way radiotelephone apparatus is to be properly identified in order to avoid mix-up with the apparatus intended for fire-fighting operations. Where the BWMS may release explosive gases, this two-way radiotelephone apparatus shall be of a certified safe type suitable for use in zone 1 hazardous areas, as defined in IEC Publication 60079. Where the BWMS stores, utilizes or introduces chemicals, the apparatus shall undergo deep cleaning or decontamination after use.

A two-way portable radiotelephone apparatus need not be required for BWMS of category 1 as per Table 1.