

**RULES
FOR THE CLASSIFICATION OF
SHIPS**

Part 1 – GENERAL REQUIREMENTS
January 2025

CROATIAN REGISTER OF SHIPPING

Hrvatska (Croatia) • 21000 Split • Marasovića 67 • P.O.B. 187
Tel.: (...) 385 (0)21 40 81 11
Fax.: (...) 385 (0)21 35 81 59
E-mail: tech.coord@crs.hr
web site: www.crs.hr

By the decision of the General Committee of Croatian Register of Shipping,

RULES FOR THE CLASSIFICATION OF SHIPS
Part 1 – GENERAL REQUIREMENTS

have been adopted on 20th December 2024 and shall enter into force on 1st January 2025

GENERAL TERMS AND CONDITIONS

(March 2022)

Article 1 GENERAL

1.1 CROATIAN REGISTER OF SHIPPING (hereinafter: the *Register*) shall at all times remain an independent contractor and neither the *Register* nor any of its officers, surveyors, auditors, inspectors, agents, appointers, officers or managers shall act as an employee, servant or agent of any other party in the performance of the Services rendered by the *Register*.

1.2 The *Register* acts as a service provider. The Services provided by the *Register* cannot be construed as a commitment by the *Register* to achieve any result or as a warranty.

1.3 The provision of Services is subject to these General Terms and Conditions. No other terms and conditions shall apply, either expressly or by implication, unless expressly agreed in writing between the Parties.

1.4 These General Terms and Conditions shall be incorporated into, or referred to in any Contract and shall prevail over and exclude any other terms and conditions that the Client may wish to impose.

Any amendments to and/or deviations from these General Terms and Conditions, as well as any additional terms and conditions of the Client, shall be binding or valid only if set forth in writing and duly signed by the authorised representatives of both Parties.

1.5 The invalidity of one or more provisions of these General Terms and Conditions shall not affect the remaining provisions.

1.6 The Client acknowledges that the latest version of these General terms and Conditions and the latest version of applicable Rules apply to the Services provided by the *Register*.

1.7 Definitions in these General Terms and Conditions take precedence over other definitions that may appear in other documents issued by the *Register*.

1.8 The Client should at all times be aware of the provisions of these General Terms and Conditions, as they may be further amended, with their latest up to date version available on the web site of the *Register*.

Article 2 DEFINITIONS

2.1 **Certificate** means either a class certificate or statutory certificate, statement, attestation, statement of compliance, and a report following the Services provided by the *Register*.

2.2 **Certification** means the activity of certification in application of international and national standards and international industry practice provided by the *Register*.

Certification is an appraisal given by the *Register* to the Client and cannot be construed as an implied or express warranty of safety, fitness for purpose, seaworthiness of the vessel or its value for sale, insurance or chartering.

The purpose of Certification is to provide classification and statutory services and assistance to the maritime industry, Flag State Administrations, and regulatory authorities relating to maritime safety and pollution prevention.

2.3 **Classification** includes all activities and Services provided by the *Register* in accordance with the Rules. Classification may or may not be accompanied by the issuance of a Certificate of class with reference to the Rules.

Certificate of class is valid only if issued by the *Register*.

However, Certificate of class should not be construed as a guarantee of the safety, fitness for purpose or seaworthiness of the vessel. It is merely an attestation that the vessel complies with the Rules developed and published by the *Register*.

In addition, the *Register* is not a guarantee of the safety of life or property at sea or the seaworthiness of a vessel because, although the classification of a vessel is based on the assumption that the vessel will be properly loaded, operated, and maintained by competent and qualified personnel, the *Register* has no control over how a vessel is operated and maintained between the periodic surveys it conducts.

2.4 **Statutory certification** means certification made by the *Register* on behalf of the Flag State Administrations when and to the extent that the *Register* has been authorised to do so by the respective Flag State.

Statutory certification and services include the assessment of vessels registered by the Flag State and/or ship management companies to determine whether such ships/companies comply with the applicable requirements of international conventions, codes and national legislation, and the issuance of, or assistance in the issuance of, the appropriate certificates and documents.

Statutory certification includes, but is not limited to, certification, survey, and issuance of statutory certificates on behalf of the Flag State.

In cases where the *Register* acts on behalf of Flag State Administrations, the *Register* shall follow guidance issued by IMO (Resolutions, Circulars, etc.) or by IACS through Unified Interpretations (UI), unless otherwise directed by the Flag State.

2.5 **Client** means the shipowner, company, shipyard and/or party requesting Services or taking ownership of a classed vessel. In cases where shipowners have authorized another party to operate the vessel on their behalf, that party shall be considered as the company.

In addition to the above the Client means the person and/or entity that has requested Services from the *Register* and that has entered into a Contract or an agreement for Services with the *Register*.

2.6 **Parties** means the *Register* and Client together.

2.7 **Party** means the *Register* or the Client.

2.8 **Contract** means the contract in the form of a written agreement between the Client and the *Register* requesting Services, including these General Terms and Conditions and the Rules.

The provisions related to the Contract in these General Terms and Conditions shall apply even if there is no written agreement between the Client and the *Register*.

The Client may request the *Register* in writing to make a change to the contracted Services. However, the *Register* shall not be obligated to accept or execute any such change until a written agreement has been signed with the Client regarding the compensation and the possible impact of the change on the schedule as an addendum to the originally contracted Services.

2.9 **Services** shall mean the services specified in 2.2, 2.3 and 2.4, but also other services related to certification, classification and statutory certification, such as, but not limited to: ISM Code certification, ISPS Code, MLC 2006 certification, fuel oil consumption reporting, IHM certification, approval of manufacturers and service providers, certification of materials and products, training activities, conformity assessment, and any other relevant activities such as third party inspections, testing, shore and shipboard trials.

The Services provided by the *Register* are performed on a random basis and in no case include a full inspection of all items.

The *Register* shall provide the Services in accordance with related Contract(s), the provisions of these General Terms and Conditions, Rules, the international and national standards, the international conventions, the EU Regulations, the Flag State requirements and the industry practices applicable to the particular Service and always assuming that the Client is aware of these standards and the industry practices.

When providing Services, the *Register* does not guarantee the accuracy of the information or advice provided.

In providing Services, the *Register* does not assess compliance with standards other than the Rules, international and national standards, international conventions, EU regulations, Flag State requirements and industry practice, to the extent agreed in writing or specified in the Contract.

2.10 The *Register* means the Croatian Register of Shipping, an entity organized and existing under Croatian law, which, according to the Law on the Croatian Register of Shipping (Official Gazette No. 1996/81, 2013/76 and 2020/62) and the Charter of the *Register*, is an independent, not-for-profit, but public welfare oriented, public foundation that performs tasks:

- classification of sea-going ships,
- statutory certification of sea-going ships on behalf of the Flag State Administrations,
- classification of inland navigation vessels,
- statutory certification of inland navigation vessels,
- statutory certification of recreational crafts,
- certification of materials and products,
- conformity assessment of recreational crafts,
- conformity assessment of marine equipment,
- conformity assessment of pressure vessels,
- certification/registration of quality management systems.

2.11 **Vessel** means a ship, vessel, unit or offshore structure of any kind, whether or not connected to the shore or sea/river bed, located at sea or in inland waters and intended for transportation or special operations on the water, as decided by the *Register*.

2.12 **Rules** means the Rules for the classification, guidelines, instructions, or other documented evidence of the *Register* related to the Services provided.

The competent interpretation of the requirements specified in the Rules or other regulations published by the *Register* shall be the exclusive responsibility of the *Register's* Head Office, notwithstanding any possible different interpretations by other parties.

In cases where the Rules do not contain detailed requirements, the specific approval by the *Register* shall be based on the principles of the Rules and shall ensure a safety standard equivalent to that of the Rules.

Article 3 RESPONSIBILITIES

3.1 It is the Client's responsibility to ensure that all surveys required for vessel's class maintenance are conducted in a timely manner and in accordance with the Rules.

3.2 The *Register* may suspend or withdraw the vessel's existing Certificate of class in the event of serious deficiencies and replace it with a new Certificate of class with a shortened period of validity during which the deficiencies are to be rectified.

In addition, the *Register* shall suspend or withdraw a vessel's Certificate of class if the deficiencies are of such a magnitude as to endanger the class of the vessel, its safety and integrity, the safety of the crew, passengers, or the marine environment, and shall require that the vessel is to be inspected at the first port of call where the necessary repairs are to be carried out.

3.3 The Client should inform the *Register*:

- (i) in the event of a change in the intended use of a vessel, a conversion and alteration of the hull, machinery installations and other equipment affecting the Class of the vessel assigned by the *Register*. Conversions and alterations must be made under the supervision of the *Register* and must comply with the requirements of the Rules and/or additional requirements of the *Register*,
- (ii) in cases where the vessel has been damaged to such an extent that the Class of the vessel is likely to be affected and the safety and integrity of the vessel is likely to be compromised. In such cases, the vessel must be surveyed at the first port of call or as further directed by the *Register*. The survey shall be to the extent deemed necessary by the *Register*, by taking into account the extent of the damage.
- (iii) in cases where class-related deficiencies and/or defects are found as a result of a Flag State inspection or Port State Control. Should the Client fail to notify the *Register* of the detention of the vessel by Port State Authorities due to class related deficiencies, the *Register* reserves the right to suspend or withdraw the Certificate of class.

3.4 The *Register* shall have full control over Certificates issued and may suspend or withdraw a Certificate at any time in its sole discretion if the Client fails to comply with the following requirements set forth in the *Rules for the Classification of Ships, Part 1 - General Requirements, Chapter 1 - General Information*, as applicable:

- (i) para. 5.3 - *Maintenance of the validity of Certificate of Class*,
- (ii) para. 5.4 - *Period of Validity*,
- (iii) para. 5.5 - *Extension of the Period of Validity*,
- (iv) para. 5.6 - *Suspension and Reinstatement of Class in the Case of Overdue Surveys*, and
- (v) para. 5.7 - *Withdrawal of Class*.

3.5 The *Register* may suspend or withdraw a Certificate at any time in its sole discretion if the Client fails to comply with the following requirements set forth in the *Rules for the Classification of Inland Navigation Vessels, Part 1 - Classification and Surveys, Chapter I - Principles of Classification*, as applicable:

- (i) para. 2.8 - *Maintenance of the Validity of the Certificate of Class*,
 - (ii) para. 2.9 - *Extension of validity of the Certificate of Class*,
- and following requirements set forth in the *Rules for the Classification of Inland Navigation Vessels, Part 1 - Classification and Surveys, Chapter II - Classification*, as applicable:

- (iii) para. 2.1 - *Suspension of Class*,
- (iv) para. 2.2 - *Withdrawal of Class*.

3.6 In addition to clauses 3.2, 3.4 and 3.5 of this Article, the *Register* reserves the right to terminate the Services and related Contract in the event of a breach of the provisions of these General Terms and Conditions.

3.7 If the Client fails to provide the *Register* with the required access or information at the agreed times or fails to prepare for the Service in a timely manner, the *Register* may suspend the provision of the Service until it receives the Client's instructions for access and/or the required information.

The *Register* shall not be liable for the consequences of such suspension, and the Client shall be responsible for the *Register's* additional fees and other unnecessary costs and expenses incurred by the *Register*.

3.8 The Client is obliged to perform timely payments of the invoices for provided Services. However, the *Register* may retain or withhold any Service or Certificate to the Client in the case of outstanding payments, whether mutually related or not, arising out of the entire business relationship with the Client.

Article 4 HEALTH, SAFETY AND ENVIRONMENT

4.1 Both the *Register* and the Client shall apply reasonable standards to promote safety, health, and environmental protection and to provide a safe working environment for their personnel.

4.2 The Client shall provide the *Register* with all access and information necessary for the safe and efficient performance of the requested Services as required by the Rules.

4.3 During the survey, personnel of the *Register* should have secure access to all work that directly or indirectly affects the Service.

4.4 The *Register* has the right to refuse to conduct an activity or visit an area or site if the *Register* in its sole discretion, believes that relevant risks are unacceptable or are not adequately addressed, contained, or otherwise mitigated.

Such a decision shall suspend the obligations of both Parties under the Contract without incurring any liability or penalty until the Parties agree on how to proceed.

Article 5 THIRD PARTIES AND SUBCONTRACTORS

5.1 Each specific Contract, including any Certificates issued, relates specifically to the Client, and no rights, obligations, interests, claims, benefits or Certificates issued shall extend to any third party without the prior written consent of the *Register*.

5.2 The Client shall not be entitled to grant any right to use the Certificates to any third party without the prior written consent of the *Register*.

5.3 The Client shall not without *Register's* consent, cede, assign, transfer, subcontract or deal in any manner with all or any of its rights or obligations under any Service and related Contract.

5.4 With regard to third party rights to access information and Certificates under confidentiality clause reference is to be made to Article 9.

Article 6 TAXES

6.1 Each Party shall be responsible for and shall bear all taxes, duties or similar governmental charges levied or imposed on any activity of that Party.

6.2 Prices, fees, rates, or remuneration are exclusive of any form of sales tax, value added tax, administrative fees and services tax and/or other similar taxes, including any surcharges. If any such indirect tax is or becomes applicable to the Services provided under the Contract, the Client shall be responsible for the payment of such indirect taxes.

Article 7 PAYMENT OF INVOICES

7.1 The provision of Services by the *Register*, whether complete or not, shall include payment of fees thirty (30) days after issuance of the invoice for the portion of the Services performed.

7.2 In the event that the Client fails to meet the requirements for payment in accordance with the instalments and terms of payment contained herein, the *Register* reserves the right to charge the Client with the interest rate in accordance with the applicable laws of the Republic of Croatia.

7.3 If the Client disputes an invoice or part of an invoice, the Client shall notify *Register* thereof in writing without undue delay. If no notification is received by the due date, Client shall be deemed to have accepted the invoice in full. If only part of an invoice is disputed, the undisputed amount must be paid by the due date.

Consequently, no disputes arising between the *Register* and the Client shall interfere with prompt payment of invoices by the Client. Any rights of lien or retention in favour of the Client or otherwise, are hereby excluded.

7.4 In the event of cancellation of all or part of the Services prior to their final completion, the Client shall pay all costs incurred by the *Register* on pro-rata basis for the portion of the Services provided to date. In such event, the *Register* will not claim the Client for loss of profit or reduced income. All reasonable costs directly attributable to the early termination and all amounts due to the *Register* at that time shall become immediately due and payable.

7.5 In the event of termination of the Service and related Contract, the *Register* shall be entitled to retain any payments, deposits or prepayments of fees made by the Client prior to the date of termination up to the amount to which the *Register* is entitled.

Article 8 TERMINATION

8.1 The Parties shall have the right to terminate the Services and the related Contract(s) by written notice to the other Party, and without prejudice to Article 7, in the following cases:

- (i) if the other Party commits a material breach of these General Terms and Conditions and/or the Contract and fails to rectify such breach in accordance with clause 8.4 of this Article,
- (ii) if the other Party becomes insolvent, is unable to pay its debts as they become due, or becomes subject to bankruptcy proceedings, administration, receivership, dissolution, liquidation, winding up or otherwise ceases to carry on its business; or
- (iii) for convenience, after giving the other Party thirty (30) days' prior written notice of termination.

8.2 The Classification issued for the relevant vessel and the Certificates previously issued shall remain valid until the effective date of termination or, in the event of such termination, immediately, subject to compliance with Article 3 and Article 7.

8.3 If, in the reasonable opinion of the *Register*, the Client breaches or is suspected of breaching Article 14 or Article 15, the *Register* shall have the right to terminate the Service and related Contract with immediate effect.

8.4 Notwithstanding the provisions of clause 8.1 of this Article, the Party intending to terminate Services for non-compliance or breach of the provisions of these General Terms and Conditions shall notify the other Party of the non-compliance or violation of the provisions of these General Terms and Conditions and set a reasonable deadline of 15 (fifteen) days for the other Party to remedy the breaches of the provisions of these General Terms and Conditions.

If the Party fails to remedy the breaches of the provisions of these General Terms and Conditions within the aforementioned period, the other Party shall have the right to terminate Services without further notice.

8.5 Termination of the Service and related Contract pursuant to the provisions of these General Terms and Conditions shall not give either Party the right to claim any additional compensation, indemnity or reimbursement from the other Party as a result of such termination, but such termination shall not affect any rights or remedies available to a Party at the time the termination becomes effective or any obligations or liabilities incurred by a Party.

Article 9 CONFIDENTIALITY

9.1 The Parties agree to keep confidential all facts, data, information, etc. related to the other Party's business that they have learned in the course of providing Services. Such information and data shall not be disclosed by the Parties to any third party and shall not be used or misused to the detriment of the other Party.

9.2 The *Register* will keep confidential any data, plans or other technical information received from the Client and will not disclose it to any third party outside the *Register*, unless authorised by the Client. This obligation shall continue to apply after termination of the Services. This obligation shall not apply to any data, plans or other technical information that was in the possession of the *Register* prior to being disclosed to the *Register* by or on behalf of the Client, or that becomes publicly available through no fault of the *Register*, or is otherwise provided to the *Register* by an independent source that is under no obligation of confidentiality to the *Register*.

9.3 Certificates issued by the *Register* to the Client as a result of the Services provided shall not be covered by the confidentiality Article.

Notwithstanding the foregoing, the Client shall be entitled to disclose any data to its affiliates involved in the transactions related to the Services or the Client's core activities.

9.4 Notwithstanding clause 9.1 and clause 9.2 of this Article, the *Register* shall have the right to disclose the Confidential Information to the following parties if required by regulations of:

- (i) authorised representatives of the Flag State Administration,
- (ii) authorised audit teams (i.e., accreditation body or EC auditors),
- (iii) the International Association of Classification Societies (IACS),
- (iv) a court of competent jurisdiction, government agency, or other relevant public authority, in accordance with applicable law, court order, or other public regulation.

9.5 The Client acknowledges that the *Register* is required to provide access to information to the EU Commission or any person acting on its behalf in accordance with applicable EU requirements and that the Client shall give the EU Commission with unrestricted access to the vessels for the purpose of inspection.

9.6 The obligations in this Article shall survive the conclusion of the Service or the termination of related Contract and shall continue for as long as the relevant information remains confidential.

Article 10 INTELLECTUAL PROPERTY

10.1 Each Party shall be the sole owner of all rights to its Intellectual Property created before or after the effective date of these General Terms and Conditions, whether or not associated with any Contract between the Parties.

10.2 The Intellectual Property developed by the *Register* for the provision of the Services, including but not limited to drawings, calculations and reports, shall remain the exclusive property of the *Register*.

Article 11 PROFESSIONAL ETHICS

11.1 Each of the Parties warrants that, with respect to the matters contemplated herein, neither it nor its affiliates has made or will make, directly or indirectly, any offer, payment, gift or authorization of money to any government official or employee, political party, public official or candidate for the benefit or advantage thereof.

11.2 In providing the Services, the *Register* shall strictly adhere to the requirements of its Code of Ethics relating to business activities.

Article 12 FORCE MAJEURE

12.1 For the purposes of these General Terms and Conditions, the term "Force Majeure" includes any event that directly or indirectly prevents the Parties from fulfilling their obligations due to events beyond their control, such as: strikes, wars, riots, piracy, civil commotion, malicious damage, pandemic, compliance with laws or government orders, rules, regulations or directives, sanctions and embargoes, accidents, defects of plants or machinery, seizures, fires, floods, storms and the like.

12.2 If either Party is prevented or delayed from performing its obligations by Force Majeure, such Party shall promptly notify the other Party in writing of the circumstances of the Force Majeure and its influence and, after such notification, shall not be liable for performance of any obligations prevented by the influence of the Force Majeure during its duration. Upon termination of the influence of the Force Majeure, the same Party should proceed with the planned activities in order to fulfil its obligations.

12.3 If one of the Parties is prevented by Force Majeure in its activities and fulfilment of its obligations and this event lasts continuously for three (3) months, the other Party shall be entitled to terminate the Service and related Contract without liability.

12.4 Neither of the Parties shall be liable for non-compliance with these General Terms and Conditions due to Force Majeure. If one of the Parties is prevented from fulfilling its obligations under these General Terms and Conditions due to Force Majeure, it shall immediately notify the other Party in writing within a reasonable period of time, stating the reasons for the Force Majeure and providing relevant evidence, if any.

Article 13 INDEMNIFICATIONS

13.1 Each Party shall indemnify the other Party against all claims arising out of the performance of the Services in respect of bodily injury, illness or death of any of its employees or other representatives and in respect of loss of or damage to the Party's property.

This provision shall apply whether or not the damage is caused or contributed to by the negligence of the other Party. Both Parties are obliged to take out separate insurances for these liabilities.

13.2 The Client shall indemnify the *Register* from and against all claims arising from the Client's violation of the provisions of these General Terms and Conditions and from the misuse of the Certificates issued by the *Register*.

13.3 The Client shall indemnify the *Register* against any financial responsibility or amounts arising from non-payment, late payment or payment of withholding taxes to the non-relevant tax authority or any other relevant governmental body.

13.4 Each Party shall notify the other Party without undue delay as soon as it becomes aware of any incident that could give rise to a claim against the other Party in respect of the Service provided and related Contract.

Article 14 ANTI-CORRUPTION

14.1 Each Party agrees that in performing its obligations under any Service, it will ensure that its affiliates, employees and/or agents, subsidiaries, subcontractors, consultants, and any other persons providing Services will:

- (i) comply with all applicable anti-bribery and anti-corruption laws (collectively, Anti-Bribery Laws) and, in particular, do not, directly or indirectly, offer, promise, grant, authorise the payment of, or confer any financial or other benefit on any public or government official:
 - to a public or governmental official to obtain or retain business with the intent to influence such official in his or her capacity as an official, if such official is not permitted or required by written law to be influenced by the offer, promise or gift; or
 - to another person with the intent to induce or reward the improper performance of a function or activity or for any other illegal purpose,
- (ii) maintain adequate systems and procedures designed to prevent activities, practises, or conduct in connection with services that would constitute an offence under an anticorruption law; and
- (iii) take reasonable steps to prevent similar acts by customers, contractors, subcontractors, agents and other third parties, persons under its control or influence.

14.2 Any failure by a Party to comply with or ensure compliance with its obligations under this Article shall, notwithstanding anything to the contrary in these General Terms and Conditions, be deemed a breach of these General Terms and Conditions which shall entitle the other Party to suspend and/or terminate the Services by notice in writing with immediate effect without further liability to the other Party except for any liability which may have arisen prior to the date of termination or suspension (as the case may be).

14.3 If a Party elects to suspend the provision of Services under these General Terms and Conditions pursuant to this Article, it shall have the sole and absolute discretion to determine:

- (i) when it will resume performance (if at all); and
- (ii) extend the period for performance of its obligations under the Services in its sole discretion.

Article 15 SANCTIONS

15.1 Each Party shall conduct all activities in compliance with all laws, statutes, rules, economic and trade sanctions (including, but not limited to, U.S. sanctions and EU sanctions) and regulations applicable to such Party, including, but not limited to: child labour, forced labour, collective bargaining, discrimination, abuse, working hours and minimum wages, anti-bribery, anti-corruption, copyright and trademark protection, personal data protection.

15.2 Each Party hereby represents and warrants that it is not or will not be subject to any economic or trade sanctions ("Sanctions") imposed by the United States of America, the European Union, the United Kingdom, any EU Member State, or the United Nations with respect to any country and/or by any sanction giver with respect to any company/individual.

15.3 Each Party represents and warrants that it will strictly comply with all Sanctions.

15.4 Nothing in these General Terms and Conditions shall be construed as causing or obligating either Party to act or refrain from acting in a manner inconsistent with, punishable by, or prohibited by any Sanctions.

15.5 Neither Party shall be obligated to perform any obligation arising under these Terms and Conditions (including, without limitation, the obligation to):

- (i) perform, deliver, accept, sell, purchase, pay or receive any funds to, from or through any person or entity; or
- (ii) engage in any other action whatsoever, if doing so violates or is inconsistent with sanctions and/or recommendations of international (intergovernmental) organisations to combat the financing of terrorism and other criminal activities and/or money laundering or exposes such Party to investigation or penalties.

15.6 In the event that a Party breaches any Sanctions or the Party's Business and/or Transactions arising out of or in connection with these General Terms and Conditions breach any Sanctions or otherwise violate the recommendations of one or more international (intergovernmental) organisations for combating the financing of terrorism and other criminal activities and/or money laundering, the other Party shall be entitled to terminate these General Terms and Conditions by written notice with immediate effect without incurring any liability to the other Party, except for liabilities (if any) incurred prior to the date of termination.

Article 16 LIABILITY

16.1 The *Register* is not, and cannot be considered as, an underwriter, consulting engineer, naval architect, shipbuilder, shipowner, or ship management company, nor can it assume the obligations and responsibilities associated with such functions, although the *Register's* experience may enable it to respond to inquiries about matters not covered by its Rules, policies, instructions, or other documented evidence.

16.2 The practices and procedures of the *Register* shall be selected by the *Register* in its sole and absolute discretion based on its experience and knowledge and in accordance with generally accepted professional standards in the relevant field of classification societies.

16.3 Nothing herein contained shall release any designer, naval architect or engineer, shipbuilder or manufacturer, shipyard, vendor, supplier, contractor or subcontractor, repairer or owner, from any information, report, certificate or similar document issued in connection with the provision of Services by the *Register*, operator, manager or other person or entity from any express or implied warranty or other contractual obligation or responsibility, or from any negligent act, error or omission of any kind whatsoever, nor shall they create any right, claim or benefit for any third party.

16.4 The *Register* shall exercise due care in the selection or appointment of its surveyors and all other employees whose presence and work is necessary for the provision of the Services.

16.5 If any person or entity using the Services of the *Register* suffers any loss, damage or expense that is or is shown to have been caused by a negligent act, omission or error of the *Register's* officers, surveyors, auditors, inspectors, agents, appointers, officers or managers, or those purporting to act in the name of and on behalf of the *Register*, or a negligent inaccuracy, advice, report or evidence given by or in the name of or/and on behalf of the *Register*, then the liability of the *Register* is limited in respect of any direct or indirect claim shall be limited to an amount not exceeding five times the fee charged or to be charged by the *Register* for the relevant Service.

16.6 Any liability for consequential damages is expressly excluded.

For purposes of this clause, consequential damages include, without limitation:

- (i) indirect or consequential damages,

- (ii) loss and/or delay of production, loss of products, loss of use, loss of bargain, loss of revenue, loss of profit or anticipated profit, loss of business and business interruption, in each case directly or indirectly.

16.7 The Parties are not entitled to assign the performance of obligations under these General Terms and Conditions or parts thereof to third parties without the prior written consent of the other Party.

16.8 If during the term of the Contract, there is a transfer of function due to change of status (merger, acquisition, division, etc.), all obligations and rights under these General Terms and Conditions and associated Contract will be transferred to the legal successor of the Party concerned.

Article 17 GOVERNING LAW AND RESOLVING OF DISPUTES

17.1 These General Terms and Conditions and any dispute or claim between the Parties arising from or in connection with it, or the Services provided hereunder, will be governed and interpreted in accordance with the English law.

17.2 The Parties shall use their reasonable efforts to resolve any claim or dispute arising in relation to rendered Service by negotiations within a reasonable time.

17.3 Should the Parties fail to resolve any claim or dispute by negotiations, the dispute shall be exclusively subject to the jurisdiction of the Permanent Arbitration Court with the Croatian Chamber of Economy in Zagreb, Republic of Croatia.

17.4 The Parties agree to keep the any arbitration proceedings confidential.

17.5 Notwithstanding the above, any claim not presented within three (3) months of the completion of the particular Services, or within three (3) months of from the date when the events which are relied on were first discovered by the Client, shall be deemed waived and absolutely time barred.

17.6 Any objections against the line adopted by any of the *Register's* servants in fulfilling their duties or against the conclusions reached are to be raised to the *Register* by the Party as soon as possible.

If the Party is not satisfied with the final conclusions and interpretations by the *Register* the arbitration lays upon the Commission for appeal for Classification and Statutory certification of ships, which is to be formed according to the Regulation 39 of the Charter of the *Register*.

Contents:

Chapter 1	GENERAL INFORMATION
1	THE RULES
2	DEFINITIONS
3	CLASSIFICATION SURVEY
4	CLASS NOTATIONS
5	CLASSIFICATION PROCEDURE
6	APPLICATION OF STATUTORY REQUIREMENTS
7	EXTERNAL AUDITS / INSPECTIONS
Chapter 2	SURVEY DURING CONSTRUCTION AND INITIAL SURVEY
1	SURVEY DURING CONSTRUCTION
2	INITIAL CLASS ENTRY SURVEY OF EXISTING SHIPS - ADMISSION TO CLASS
Chapter 3	TYPE APPROVAL OF PRODUCTS
1	GENERAL INFORMATION
2	TYPE APPROVAL
Chapter 4	APPROVAL OF MANUFACTURERS AND SERVICE SUPPLIERS
1	APPROVAL OF MANUFACTURERS
2	APPROVAL OF SERVICE SUPPLIERS
Chapter 5	SURVEYS OF SHIPS IN SERVICE
1	GENERAL REQUIREMENTS
2	TYPE OF SURVEYS
3	PREPARATIONS, CONDITIONS AND DOCUMENTATION FOR SURVEY
4	ANNUAL SURVEY
5	INTERMEDIATE SURVEY
6	BOTTOM SURVEY
7	RENEWAL SURVEY
8	RENEWAL SURVEY REQUIREMENTS FOR MACHINERY
9	SURVEY OF THE AUTOMATION SYSTEMS
10	PROPELLER AND PROPELLER SHAFT SURVEY
11	ELECTRICAL EQUIPMENT
12	REFRIGERATING PLANT
ANNEX A	Hull Surveys of Chemical Tankers
ANNEX B	Hull Surveys of Double Hull Oil Tankers
ANNEX C1	Hull Surveys of Single Skin Bulk Carriers
ANNEX C	Hull Surveys of Double Skin Bulk Carriers
ANNEX D	Sketches
ANNEX E	Periodic Survey of Fuel Installations on Ships other than Liquefied Gas Carriers Utilizing Gas or Other Low Flash Point Fuels
Chapter 6	REQUIREMENTS FOR ADDITIONAL CLASS NOTATIONS
1	ADDITIONAL CLASS NOTATIONS
2	BATTERY SYSTEM (BAT)
3	CRUDE OIL WASHING (COW)
4	IN-WATER SURVEY (IWS)
5	ASPHALT CARRIERS
6	CYBER RESILIENCE
7	SHIPS CARRYING INDUSTRIAL PERSONNEL
8	TRANSHIPPING UNITS
9	MOBILE STORAGE UNITS

REVIEW OF AMENDMENTS IN RELATION TO PREVIOUS EDITION OF THE RULES

RULES FOR THE CLASSIFICATION OF SHIPS

Part 1 - GENERAL REQUIREMENTS

Chapter 5 – Surveys of ships in service

All major changes in respect to Rules for the classification of ships, Part 1 – General requirements, Chapter 5 – Surveys of ships in service, edition July 2024, throughout the text are shaded (if any).

Items not being indicated as corrected have not been changed.

The grammar and print errors have been corrected throughout the Rules and are not subject to above indication of changes.

Chapter 5 SURVEYS OF SHIPS IN SERVICE

The subject Chapter of the Rules includes the requirements of the following international Organisations:

International Maritime Organization (IMO)

Codes: International Code on the Enhanced Programme of Inspections During Surveys of Bulk Carriers and Oil Tankers, 2011 (2011 ESP CODE), as amended by MSC.405(96), MSC.412(97), MSC.461(101), MSC.483(103), MSC.525(106)

Resolutions: A.1050(27), MSC.474(102), **A.1186(33)**

Circulars: MSC.1/Circ.1432 (Revised Guidelines for the maintenance and inspection of fire protection systems and appliances)
MSC.1/Circ.1516 (Amendments to Revised Guidelines for the maintenance and inspection of fire protection systems and appliances (MSC1/Circ.1432))
MSC.1/Circ.1318/Rev.1 (Revised Guidelines for the maintenance and inspection of fixed carbon dioxide fire-extinguishing systems)
MSC.1/Circ.1330/Rev.1 (Guidelines for maintenance and repair of protective coatings)
MSC.1/Circ.1572/Rev.2 (Unified interpretations of SOLAS Chapters II-1 and XII, of the technical provisions for means of access)
MSC.1/Circ.1620 (Guidelines for inspection and maintenance of mooring equipment including lines)
MSC.1/Circ.1175/Rev1 (Revised guidance on shipboard towing and mooring equipment)

International Association of Classification Societies (IACS)

Unified Requirements (UR):

A1.6 (Sep 2021, rev.7, corr.1), F7 (Nov 2020, rev.3, corr.1), M79 (Feb 2020, rev.1), S1 (May 2010, rev.7), S1A (May 2010, rev.6), S8 (Dec 2010, rev.4), S9 (Dec 2010, rev.6), S14 (Dec 2022, rev.7), S15 (Nov 2003, rev.1), S19 (Jul 2004, rev.5), S21 (May 2010, rev.5) S23 (Aug 2007, rev.4), Z1 (**Sep 2024, rev.10**), Z3 (Apr 2019, rev.8), Z6 (Jun 2015, rev.6), Z7 (**May 2024, rev.29 corr.1**), Z7.1 (**May 2024, rev.15 corr.1**), Z8 (1995, rev.1), Z9 (1996, rev.2, corr. 1997), Z10.1 (Feb 2023, rev.25), Z10.2 (Feb 2023, rev.37), Z10.3 (Aug 2023, rev.21), Z10.4 (Feb 2023, rev.18), Z10.5 (Feb 2023, rev.20), Z13 (Jan 2011, rev.3), Z18 (Apr 2020, rev.9), Z19 (Apr 1999), Z20 (May 2019, rev.2), Z21 (Oct 2015, rev.4), Z24 (Jul 2011, corr.1), Z25 (Sep 2017, rev. 1), Z27 (Jul 2018), Z28 (Jun 2021, corr.1), Z29 (Mar 2022)

Unified Interpretations (UI):

SC 249 (Feb 2013, rev.1), SC 212 (Nov 2023, rev. 1)

Procedural Requirements:

PR19 (Jul 2017, rev.1), PR20 (May 2019, rev.3), PR33 (Jul 2009), PR37 (Sep 2023, rev.3), PR41 (May 2022)

Recommendations:

No. 36 (Nov 2020, rev.3), No. 39 (Mar 2009, rev.3), No. 53 (Oct 2023, rev.1), No. 72 (Apr 2018, rev.3), No 77 (Oct 2017, rev.4), No. 87 (May 2015, rev.2), No. 111 (Jun 2018, rev.1), No. 131 (Jul 2013), No. 133 (Nov 2013), No. 143 (Oct 2015), No. 144 (Feb 2016)

Contents:

	Page
1 GENERAL REQUIREMENTS	1
1.1 APPLICATION	1
1.2 DEFINITIONS	1
1.3 DUTIES OF THE COMPANY	2
2 TYPE OF SURVEYS.....	3
2.1 INITIAL SURVEY	3
2.2 REGULAR SURVEYS.....	3
2.3 ALTERNATIVE SURVEYS.....	3
2.4 BOTTOM SURVEY	8
2.5 SURVEY OF PROPELLERS AND PROPELLER SHAFTS	10
2.6 OTHER SURVEYS	10
3 PREPARATIONS, CONDITIONS AND DOCUMENTATION FOR SURVEY	11
3.1 SURVEY PROGRAMME FOR SHIPS WITH AFFIXED ESP NOTATION	11
3.2 PREPARATIONS AND CONDITIONS FOR SURVEY – ALL SHIPS	14
3.3 DOCUMENTATION	18
3.4 REQUIREMENTS FOR SAFE ENTRY TO CONFINED SPACES	18
4 ANNUAL SURVEY	20
4.1 GENERAL.....	20
4.2 HULL AND HULL EQUIPMENT SURVEY - STEEL SHIPS, ALUMINIUM ALLOY SHIPS - ALL SHIPS....	20
4.3 HULL AND HULL EQUIPMENT SURVEY - WOODEN SHIPS, AND FIBER REINFORCED PLASTIC SHIPS - ALL SHIPS	22
4.4 MACHINERY, ELECTRICAL EQUIPMENT AND FIRE PROTECTION - ALL SHIPS	23
4.5 ADDITIONAL ANNUAL SURVEY REQUIREMENTS FOR OIL TANKERS WITH AFFIXED ESP NOTATION OTHER THAN DOUBLE HULL OIL TANKERS	25
4.6 ADDITIONAL ANNUAL SURVEY REQUIREMENTS FOR BULK CARRIERS WITH AFFIXED ESP NOTATION.....	26
4.7 ANNUAL SURVEY REQUIREMENTS FOR CHEMICAL TANKERS	26
4.8 ADDITIONAL ANNUAL SURVEY REQUIREMENTS FOR SHIPS WITH INERT GAS SYSTEM FITTED .	27
4.9 ANNUAL SURVEY REQUIREMENTS FOR FLOATING UNITS.....	28
4.10 ADDITIONAL ANNUAL SURVEY REQUIREMENTS AFTER DETERMINING COMPLIANCE WITH SOLAS 74, CH. II-I/25, FOR GENERAL CARGO SHIPS WITH SINGLE HOLD	28
4.11 ADDITIONAL ANNUAL SURVEY REQUIREMENTS FOR GENERAL DRY CARGO SHIPS.....	28
4.12 ADDITIONAL ANNUAL SURVEY REQUIREMENTS FOR LIVE-STOCK CARRIERS	29
4.13 ADDITIONAL ANNUAL SURVEY REQUIREMENTS FOR FAST VESSELS	29
4.14 ADDITIONAL ANNUAL SURVEY REQUIREMENTS FOR RO-RO CARGO SHIPS, PASSENGER SHIPS, RO-RO PASSENGER SHIPS.....	29
4.15 ADDITIONAL ANNUAL SURVEY REQUIREMENTS FOR TECHNICAL FLOATING UNITS	32
4.16 ADDITIONAL ANNUAL SURVEY REQUIREMENTS FOR TUGS AND SUPPLY VESSELS.....	32
4.17 ADDITIONAL ANNUAL SURVEY REQUIREMENTS FOR FISHING VESSELS	32
4.18 ADDITIONAL ANNUAL SURVEY REQUIREMENTS FOR ASPHALT CARRIERS	32
4.19 ADDITIONAL ANNUAL SURVEY REQUIREMENTS FOR THE VESSELS WITH ADDITIONAL CHARACTER OF CLASS “BAT” ASSIGNED	33
5 INTERMEDIATE SURVEY	34
5.1 GENERAL.....	34
5.2 HULL AND HULL EQUIPMENT SURVEY - ALL SHIPS	34
5.3 MACHINERY, ELECTRICAL EQUIPMENT AND FIRE PROTECTION ARRANGEMENTS - ALL SHIPS .	34
5.4 ADDITIONAL INTERMEDIATE SURVEY REQUIREMENTS FOR OIL TANKERS WITH AFFIXED ESP NOTATION OTHER THAN DOUBLE HULL OIL TANKERS	34
5.5 ADDITIONAL INTERMEDIATE SURVEY REQUIREMENTS FOR BULK CARRIERS WITH AFFIXED ESP NOTATION.....	36
5.6 ADDITIONAL INTERMEDIATE SURVEY REQUIREMENTS FOR ASPHALT CARRIERS.....	36
5.7 ADDITIONAL INTERMEDIATE SURVEY REQUIREMENTS FOR CHEMICAL TANKERS	37
5.8 ADDITIONAL INTERMEDIATE SURVEY REQUIREMENTS FOR GENERAL DRY CARGO SHIPS.....	37

5.9	ADDITIONAL REQUIREMENTS AFTER DETERMINING COMPLIANCE WITH SOLAS 74, CH. II-I/25, FOR GENERAL CARGO SHIPS WITH SINGLE HOLD	37
6	BOTTOM SURVEY	39
6.1	GENERAL	39
6.2	DOCKING SURVEY	39
6.3	IN-WATER SURVEY	40
7	RENEWAL SURVEY.....	42
7.1	GENERAL.....	42
7.2	HULL AND HULL EQUIPMENT REQUIREMENTS - STEEL SHIPS, ALUMINIUM ALLOY SHIPS	42
7.3	HULL, HULL EQUIPMENT AND MACHINERY REQUIREMENTS - WOODEN SHIPS, AND FIBRE REINFORCED PLASTIC SHIPS	44
7.4	FIRE PROTECTION - ALL SHIPS	46
7.5	THICKNESS MEASUREMENT AND REPORTING	47
7.6	CLOSE-UP SURVEY.....	47
7.7	RENEWAL SURVEY ADDITIONAL REQUIREMENTS FOR OIL TANKERS WITH AFFIXED ESP NOTATION OTHER THAN DOUBLE HULL OIL TANKERS	47
7.8	ADDITIONAL RENEWAL SURVEY REQUIREMENTS FOR CHEMICAL TANKERS	50
7.9	ADDITIONAL RENEWAL SURVEY REQUIREMENTS FOR SHIPS WITH INERT GAS SYSTEM FITTED.....	51
7.10	RENEWAL SURVEY REQUIREMENTS FOR FLOATING UNITS	51
7.11	RENEWAL SURVEY REQUIREMENTS FOR TECHNICAL FLOATING UNITS	51
7.12	ADDITIONAL RENEWAL SURVEY REQUIREMENTS FOR GENERAL DRY CARGO SHIPS	52
7.13	ADDITIONAL RENEWAL SURVEY REQUIREMENTS FOR LIVE-STOCK CARRIERS.....	53
7.14	ADDITIONAL RENEWAL SURVEY REQUIREMENTS FOR FAST VESSELS.....	53
7.15	ADDITIONAL RENEWAL SURVEY REQUIREMENTS FOR RO-RO CARGO SHIPS, PASSENGER SHIPS, RO-RO PASSENGER SHIPS	54
7.16	ADDITIONAL RENEWAL SURVEY REQUIREMENTS FOR TUGS AND SUPPLY VESSELS	54
7.17	ADDITIONAL RENEWAL SURVEY REQUIREMENTS FOR FISHING VESSELS	55
7.18	ADDITIONAL RENEWAL SURVEY REQUIREMENTS FOR ASPHALT CARRIERS	55
8	RENEWAL SURVEY REQUIREMENTS FOR MACHINERY	66
8.1	PROPULSION SYSTEM - SURVEY REQUIREMENTS	66
8.2	MACHINERY VERIFICATION RUNS	66
8.3	AUXILIARY MACHINERY - SURVEY REQUIREMENTS	66
8.4	REDUCTION GEAR AND CLUTCHES - SURVEY REQUIREMENTS	66
8.5	TURBINES - SURVEY REQUIREMENTS.....	67
8.6	BOILERS - SURVEY REQUIREMENTS.....	67
8.7	PIPING AND PIPING ARRANGEMENT - SURVEY REQUIREMENTS	68
8.8	STEAM PIPES - SURVEY REQUIREMENTS.....	68
8.9	HEAT TRANSFER DEVICES - SURVEY REQUIREMENTS	68
8.10	PRESSURE VESSELS - SURVEY REQUIREMENTS	68
8.11	REQUIREMENTS FOR TESTING OF PERMANENTLY INSTALLED BREATHING GAS CONTAINERS ONBOARD DIVING VESSELS	69
8.12	SURVEY OF TOWING WINCH EMERGENCY RELEASE SYSTEMS SUBJECT TO IACS UR M79	69
9	SURVEY OF THE AUTOMATION SYSTEMS	70
9.1	GENERAL.....	70
9.2	ANNUAL SURVEY REQUIREMENTS.....	70
9.3	RENEWAL SURVEY REQUIREMENTS.....	70
10	PROPELLER AND PROPELLER SHAFT SURVEY	71
10.1	FREQUENCY OF SURVEYS.....	71
10.2	COMPLETE SURVEY	71
10.3	MODIFIED SURVEY	72
10.4	PARTIAL SURVEY	72
10.5	DETERMINATION OF METALS AND OTHER CONTAMINANTS IN STERN TUBE LUBRICANTS	73
10.6	SURVEYS OF PROPELLER SHAFTS AND TUBE SHAFTS.....	76
10.7	PROPELLER SHAFT CONDITION MONITORING (PMON).....	83

11	ELECTRICAL EQUIPMENT	84
11.1	ANNUAL AND INTERMEDIATE SURVEYS.....	84
11.2	COMPLETE SURVEYS	84
11.3	SURVEYS OF ELECTRICAL EQUIPMENT DURING DOCKING SURVEY	85
12	REFRIGERATING PLANT.....	86
12.1	ANNUAL SURVEY REQUIREMENTS	86
12.2	RENEWAL SURVEY REQUIREMENTS.....	87

ANNEX A - HULL SURVEYS OF CHEMICAL TANKERS

ANNEX B - HULL SURVEYS OF DOUBLE HULL OIL TANKERS

ANNEX C1 - HULL SURVEYS OF SINGLE SKIN BULK CARRIERS

ANNEX C - HULL SURVEYS OF DOUBLE SKIN BULK CARRIERS

ANNEX D - SKETCHES

ANNEX E - PERIODIC SURVEY OF FUEL INSTALLATIONS ON SHIPS OTHER THAN LIQUIFIED GAS CARRIERS UTILIZING GAS OR OTHER LOW FLASH FUEL

1 GENERAL REQUIREMENTS

1.1 APPLICATION

1.1.1 The requirements of this Chapter of the Rules for the classification of ships (hereafter referred to as: the Rules) of *CROATIAN REGISTER OF SHIPPING* (hereafter referred to as: the *Register*) are applicable to existing ships subjected to classification survey by the *Register*.

While performing surveys the requirements of the Rules relating to ships in service are applicable. Each specific case not covered by the Rules is considered separately in extent as deemed necessary by the *Register*.

1.1.2 This Chapter of the Rules is not applicable to existing ships in cases of major modifications or conversions, significant repairs, modifications or alternations of the equipment, as well as, when the purpose of the ship, navigation area or number of passengers onboard occurs.

1.1.3 For all other class type notations not specifically listed requirements for all ships apply. For the requirements on periodical class surveys for the maintenance of additional or descriptive class notations refer to the *Rules for the classification of ships, Part 1- General requirements, Chapter 6 – Requirements for additional class notations*.

1.2 DEFINITIONS

1.2.1 **Ballast tank** - a tank that is being used primarily for saltwater ballast.

A Combined Cargo/Ballast Tank is a tank which is used for the carriage of cargo or ballast water as a routine part of the vessel's operation and will be treated as a Ballast Tank. Cargo tanks in which water ballast might be carried only in exceptional cases per MARPOL 73/78 Annex I/18(3) are to be treated as cargo tanks.

1.2.2 **Spaces** - separate compartments such as holds and tanks, tanks, cofferdams, and void spaces bounding cargo holds, decks and the outer hull.

1.2.3 **Overall survey** - a survey intended to report on overall condition of the hull structure and to determine the extent of additional Close-up survey.

1.2.4 **Close-up survey** - a survey where the details of structural components are within the close visual inspection range of the Surveyor, i.e. normally within reach of hand.

1.2.5 **Transverse section** - includes all longitudinal members such as plating, longitudinals and girders at the deck, side, bottom, inner bottom, and longitudinal bulkheads. For transversely framed ships, a transverse section includes adjacent frames and their end connections in way of transverse sections.

1.2.6 **Representative spaces** - those spaces which are expected to reflect the conditions of other spaces of similar type and service and with similar corrosion prevention systems. When selecting representative spaces, account is to be taken of the service and repair history on board and identifiable Critical Structural Areas and/or Suspect areas.

1.2.7 **Suspect areas** - locations showing Substantial corrosion and/or are considered by the Surveyor to be prone to rapid wastage.

1.2.8 **Substantial corrosion** - an extent of corrosion such that assessment of corrosion pattern indicates a wastage in excess of 75 % of allowable margins, but within acceptable limits.

For vessels built under the IACS Common Structural Rules, substantial corrosion is an extent of corrosion such that the assessment of the corrosion pattern indicates a gauged (or measured) thickness between $t_{net} + 0.5$ [mm] and t_{net} .

1.2.9 **Corrosion prevention system** - is normally considered a **full hard protective coating**.

Hard Protective Coating is usually to be epoxy coating or equivalent. Other coating systems, which are neither soft nor semi-hard coatings, may be considered acceptable as alternatives, provided that they are applied and maintained in compliance with the manufacturer's specifications.

1.2.10 **Coating condition** - is defined as follows:

1. **GOOD** - condition with only minor spot rusting.
2. **FAIR** - condition with local breakdown at edges of stiffeners and weld connections and/or light rusting over 20 % or more of areas under consideration, but less than as defined for POOR condition.
3. **POOR** - condition with general breakdown of coating over 20 % or more, or hard scale at 10% or more, of areas under consideration.

NOTE: Reference is made to IACS Recommendation No. 87 "Guidelines for Coating Maintenance & Repairs for Ballast Tanks and Combined Cargo/Ballast Tanks on Oil Tankers".

1.2.11 **Critical structural areas** - locations which have been identified from calculations to require monitoring or from the service history of the subject ship or from similar or sister ships, if applicable to be sensitive to cracking, buckling or corrosion which would impair the structural integrity of the ship.

1.2.12 **Cargo length area** - that part of the ship which contains all cargo holds and adjacent areas including fuel tanks, cofferdams, ballast tanks and void spaces (or for tankers all cargo tanks, slop tanks, cargo/ballast pump rooms, cofferdams, ballast tanks and void spaces adjacent to cargo tanks and also deck areas throughout the entire length and breadth of the ship over the above mentioned spaces).

1.2.13 **Special consideration** - Special consideration or specially considered (in connection with close-up surveys and thickness measurements) means sufficient close-up inspection and thickness measurements are to be taken to confirm the actual average condition of the structure under the coating.

1.2.14 **Remote Inspection Techniques (RIT)**. Remote Inspection Technique is a means of survey that enables examination of any part of the structure without the need for direct physical access of the surveyor (refer to IACS Rec. 42).

1.2.15 **Corrosion protection coatings for cargo hold spaces on bulk carriers**. New bulk carriers (built on or after 1st July 1998) are to have an efficient hard protective coating

(epoxy coating or equivalent) applied in accordance with the manufacturer's recommendation on all internal and external surfaces of hatch coamings and hatch covers, and all internal surfaces of the cargo holds, excluding the flat tank top areas and the hopper tanks sloping plating approximately 300 [mm] below the side shell frame and brackets.

For acceptable guidelines for maintenance and repair of protective coatings refer to MSC.1/Circ.1330/Rev.1.

For existing bulk carriers built before 1st July 1998, where the Company may elect to coat or re-coat cargo holds as noted above, consideration may be given to the extent of the Close-up and thickness measurement surveys. Prior to the coating of cargo holds of existing ships, scantlings are to be ascertained in the presence of the Surveyor.

1.2.16 Oil tanker - an Oil Tanker is a ship which is constructed primarily to carry oil in bulk in cargo tanks forming an integral part of the ship's hull, including ship types such as combination carriers (Ore/Oil ships, etc.), but excluding ships carrying oil in independent tanks not part of the ship's hull.

1.2.17 All other definitions related to this Chapter are given in the Annex A, Annex B, Annex C, Annex C1, Annex E and in the *Rules for the classification of ships, Part 1 – General requirements, Chapter 1 – General information, Section 2*.

1.2.18 Prompt and Thorough Repair - is a permanent repair completed at the time of survey to the satisfaction of the Surveyor, therein removing the need for the imposition of any associated condition of classification.

1.2.19 Air pipe heads installed on the exposed decks - are those pipe heads extending above the freeboard deck or superstructure deck.

1.2.20 General Dry Cargo Ships - are all self-propelled ships of 500 GT and above carrying solid cargoes other than ¹⁾:

- bulk carriers with affixed ESP notation,
- dedicated container carriers,
- dedicated forest product carriers (not timber or log carriers),
- Ro-Ro cargo ships,
- refrigerated cargo ships,
- dedicated wood chip carriers,
- dedicated cement carriers,
- livestock carriers,
- deck cargo ships (see Note ²⁾),
- general dry cargo ships of double side-skin construction, with double side-skin extending for the length of the cargo area, and for the height of the cargo hold to the upper deck (see Note ³⁾).

NOTE ¹⁾: The requirements of paragraphs 4.10, 5.9 and 7.2.15 also apply to those cargo ships, which, although belonging to the ship types listed in 1.1.1 that are excluded from the application of this definition, are fitted with a single cargo hold.

NOTE ²⁾: A deck cargo ship is a ship that is designed to carry cargo exclusively above deck without any access for cargo below deck.

NOTE ³⁾: Special consideration may also be given to ships that are of double side-skin construction but with single skin in way of several frame spaces e.g. in way of a cargo hold entrance or in way of fore-body hull form at the forward end of the foremost cargo hold.

1.2.21 For General Dry Cargo Ships with hybrid cargo hold arrangements, e.g. with some cargo holds of single-side skin and others of double-side skin, the requirements for General Dry Cargo Ships are to be applied only to structure in way of the single-side skin cargo hold region.

1.2.22 Company - Shipowner, as defined in 2.12 of the *Rules for the classification of ships, Part 1 – General requirements, Chapter 1 – General information*.

1.2.23 Confined Space - Confined Space means a space that has any of the following characteristics:

- Limited openings for entry and exit.
- Unfavourable natural ventilation.
- Not intended for continuous worker occupancy.

It may include, but is not limited to: boilers, pressure vessels, cargo spaces (cargo holds, or cargo tanks), enclosed cargo space access trunks, ballast tanks, double bottoms, double hull spaces, fuel oil tanks, lube oil tanks, sewage-tanks, pump-rooms, compressor rooms, cofferdams, void spaces, duct keels, inter-barrier spaces, engine crankcases, excavations and pits.

1.2.24 Adjacent Space & Connected Space - Adjacent space means a space that shares a common boundary with a compartment that contains a hazardous atmosphere. Such a space has no opening or connections into the hazardous compartment whatsoever and is a contiguous barrier. Such a space may only contain a hazardous atmosphere in the event of the failure of that barrier.

Connected space means a space that is connected, by either permanent or intermittent means to a source space that may contain a hazardous atmosphere. A space separated by a door shall be considered 'connected' as it is impossible to tell from outside the space whether it is open or not. A connected space shall be seen as containing a hazardous atmosphere until testing proves otherwise as that atmosphere could be trapped.

1.3 DUTIES OF THE COMPANY

1.3.1 Surveys are performed on the basis of a request submitted by the Company or her representative. The Company is responsible for the organisation of the survey in accordance with the terms stated in the Rules, as well as for keeping certificates, books and other documents issued by the *Register* valid.

1.3.2 The Company is to inform the *Register* without any delay in cases stated in the *Rules for the classification of ships, Part 1 - General requirements, Chapter 1 - General information, 3.11*.

1.3.3 The Company should supply and maintain on board documentation as specified in 3.3.

Operating and maintenance instructions and drawings required for the main propulsion and all other essential services are to be in a language understood by the engineering officers and crew.

1.3.4 The Company is to provide Conditions for survey as specified in 3.2.

2 TYPE OF SURVEYS

2.1 INITIAL SURVEY

See the *Rules for the classification of ships, Part 1 - General requirements, Chapter 2 – Survey during construction and initial survey, 2.2.*

2.2 REGULAR SURVEYS

2.2.1 General

2.2.1.1 Regular surveys are obligatory surveys to which a ship is subjected in time intervals prescribed by the Rules and should be conducted at once or according to Continuous survey scheme in allowed time window.

Ships on the Continuous survey system are not exempted from other regular surveys (i.e. Intermediate survey).

2.2.2 Annual survey

2.2.2.1 An Annual survey is a general inspection of the items covered by the Rules and is to be held within three months before or after each anniversary date of the Certificate of Class. An Annual survey should enable the *Register* to verify that the condition of hull structures, machinery installations and equipment is being maintained in accordance with the Rules.

2.2.3 Intermediate survey

2.2.3.1 An Intermediate survey is an inspection of the items covered by the Rules and should enable the *Register* to verify that the ship is being properly maintained taking in account the purpose of the ship.

2.2.3.2 The Intermediate survey should be held within three months before or after the second anniversary date or within three months before or after the third anniversary date of the Certificate of Class and should take the place of one of the Annual surveys. Survey of the items, additional to Annual survey requirements (regarding ballast tanks and cargo holds), may commence at the second Annual survey and be progressed during the succeeding year with a view to completion by the end of the third Annual survey (i.e. during 18 (eighteen) month time window).

2.2.4 Renewal survey

2.2.4.1 Renewal survey is an inspection of items relevant to the Certificate of Class that include in addition to the requirements of the Annual survey, examination, test and checks of sufficient extent to ensure that they are in a satisfactory condition and fit for the service for which the ship is intended for the next period of validity of the Certificate of Class with the requirement that it is properly maintained and subjected to surveys as it is prescribed by the Rules.

Renewal survey may commence at the 4th Annual survey and be progressed with a view to completion by the 5th anniversary date. When the Renewal survey is com-

menced prior to the 4th Annual survey, the entire survey is to be completed within 15 months if such work is to be credited to the Renewal survey. For such surveys carried out on several occasions or split between different survey stations, surveyed items are to be recorded on a master list of hull items (Renewal Survey List – Hull).

A survey meeting is to be held prior to the commencement of the survey (see also 3.2.5).

As a part of the preparation for the Renewal survey, thickness measurement may be carried out. Results of the thickness measurement may not be accepted for the Renewal survey if they were obtained more than fifteen months prior to the due date of the Renewal survey.

2.2.4.2 If the Renewal survey has been completed within time interval of 3 (three) months before the due date of the Certificate of Class, the new certificate is to be issued according to the due date of such previously issued certificate.

If the Renewal survey has been completed more than 3 (three) months before the due date of the Certificate of Class, the new certificate is to be issued according to the date of the completion of such survey.

If the Renewal survey has been completed after the due date of the Certificate of Class, the new certificate is to be issued according to the due date of such previously issued certificate (see the *Rules for the classification of ships, Part 1 – General requirements, Chapter 1 – General information, 5.5*).

If the Renewal survey has been performed concurrently with major repairs / reconstruction / modifications, for completion of which longer period of time is needed, the new Certificate of Class will be issued according to the date of the completion of such repairs / reconstruction / modifications.

2.2.4.3 Renewal survey leads to the issue of a new Certificate of Class, while other regular survey leads to the endorsement of existing Certificate of Class.

2.3 ALTERNATIVE SURVEYS

Owner's hull inspection and maintenance schemes shall be encouraged as means for maintaining compliance with classification and statutory requirements between the surveys. However, these schemes are not to be accepted as an alternative to, or a substitute for, the performance of required classification and/or statutory surveys of the hull by the Surveyors of the *Register*, or of another IACS class society with which the ship is dually classed.

2.3.1 Continuous survey

2.3.1.1 The *Register* may, upon request from the Company, as an alternative to the Renewal surveys accept Continuous surveys of the hull structures (CSH) and/or machinery installations (CSM) and/or refrigerating plant installations (CSR). Instead of surveys being performed at once (as stated for Renewal survey), according to the Continuous survey scheme it is allowed that every year, 20 to 25 % of the items covered by the Continuous hull and/or machinery and/or refrigerating plant survey scheme are to be surveyed, with a condition that all the items are to be surveyed within the expiry date of the Certificate of Class. The interval between consecutive examinations of each item is not to exceed five (5)

years (with possibility of postponement for up to three months). Satisfactory completion of the items of Continuous survey is a prerequisite for issuing the new Certificate of Class.

2.3.1.2 Continuous survey scheme for hull is not allowed for oil tankers, chemical tankers, bulk carriers, ore carriers and combination carriers on which the Enhanced Survey Programme is applied and for general dry cargo ships.

For those and other ships that are not surveyed according to Continuous survey scheme see 2.2.4.1.

2.3.1.3 Ships covered by the Continuous hull and/or machinery and/or refrigerating plant survey scheme are not exempted from the Annual and Intermediate surveys. For ships more than 10 years of age, the ballast tanks are to be internally examined twice in each period of validity of the Certificate of Class, i.e. once within the scope of the intermediate survey and once within the scope of the continuous system for the hull Renewal survey.

2.3.1.4 A special note is to be stated in the Certificate of Class if the Continuous hull and/or machinery and/or refrigerating plant survey scheme is applied.

2.3.1.5 The *Register* may, upon request of the Company, accept that some of the Continuous machinery survey items may be carried out by the Chief Engineer. The conditions for granting this type of survey arrangement, as well as its extent are stated in 2.3.2.

2.3.2 Surveys by the Chief Engineer

2.3.2.1 The *Register* may, as stated in 2.3.1, upon the Company's, accept that part of the Continuous machinery surveys may be carried out by the Chief Engineer. The conditions for granting this type of survey arrangement will normally be:

- .1 The Company must confirm the required qualifications for the Chief Engineer.
- .2 Half of all items by the Continuous machinery survey scheme, of which there are more than one, may be surveyed by the Chief Engineer (i.e. the Chief Engineer may survey half of all identical items in one cycle of the class term). Auxiliary diesel engines and turbines may wholly be surveyed by the Chief Engineer.
- .3 All surveys carried out under supervision of the Chief Engineer are to be recorded in the engine logbook and relevant extracts are to be submitted to the *Register*.

2.3.2.2 The Chief Engineer is to obey the following regulations:

- .1 All surveys taking place at ports where the *Register* is represented are to be carried out by the Surveyors.
- .2 The Chief Engineer is not allowed to perform the survey of the same item twice successively.
- .3 Generator parallel operation, generator load test, and testing of protection devices for generators and switchboards are to be witnessed by the Surveyor.

- .4 Test run, including testing of safety functions of auxiliary diesel engines and turbines are to be carried out by the Surveyor.
- .5 Survey of the items covering automation is to be carried out by the Surveyor.
- .6 Survey of the pressure vessels is to be carried out by the Surveyor.

2.3.3 Survey arrangement based on approved planned maintenance scheme for machinery

2.3.3.1 For items of machinery and automation system which are subject to the Continuous machinery survey scheme (CSM, see 2.3.1) the *Register* may grant an approval of the planned maintenance scheme (PMS) and a survey arrangement adopted stating the extent and method of survey. This scheme is limited to components and systems covered by CSM.

2.3.3.2 Approved PMS considers surveys to be carried out on the basis of intervals between overhauls recommended by manufacturers, documented operator's experience and condition monitoring where fitted.

In general, the intervals for PMS shall not exceed those specified for CSM. However, for components where the maintenance is based on running hours longer intervals may be accepted as long as the intervals are based on the manufacturers' recommendations.

2.3.3.3 The Chief Engineer is responsible person on board in charge with the PMS. Documentation on overhauls of items covered by the PMS shall be reported and signed by the chief engineer.

2.3.3.4 Any items not covered by the PMS shall be surveyed and credited in the usual way.

2.3.3.5 The approval of the PMS machinery shall be based on a concentrated description of the maintenance system sufficiently detailed to serve as basis for the approval.

The approval documentation is to be in the English language and is to be submitted by the Company.

2.3.3.6 To be considered for approval of a PMS, the Company is to make a formal request to the *Register* accompanied by the following information and documents:

- .1 Documentation to be submitted initially:
 - a) organisation chart identifying areas of responsibility,
 - b) documentation filling procedures,
 - c) listing of equipment to be considered by classification in PMS,
 - d) machinery identification procedure,
 - e) preventive maintenance sheet(s) for each machine to be considered,
 - f) listing and schedule of preventive maintenance procedures.
- .2 In addition to the above documentation the following information shall be available on board:
 - a) all clauses in 2.3.3.6.1 in an up-to-date fashion,
 - b) maintenance instructions (manufacturer's, and/or shipyard's),

- c) reference documentation (trend investigation procedures, etc.),
- d) records of maintenance including repairs and renewals carried out.

2.3.3.7 An annual report covering the years' service, including the information as required under the clauses 2.3.3.6.1c) and 2.3.3.6.1e) as well as the information on changes to other clauses in 2.3.3.6.1, shall be given to the *Register* for review:

2.3.3.8 When the PMS is approved an approval document for survey arrangement will be issued for the vessel stating the extent and method of survey. The approval document is to be kept onboard.

2.3.3.9 The PMS shall be programmed and maintained by a computerised system. However, this may not be applied to the current already approved schemes.

The documentation used in the PMS in the form of books, set of cards, etc. are to be given a specific identification for later references.

Access to computerized systems for updating of the maintenance documentation and maintenance program shall only be permitted by the chief engineer or other authorized person. Computerised systems are to include back-up disks/tapes or CDs, which are to be updated at regular intervals. Computerised systems are to be approved by the *Register*.

2.3.3.10 The implementation survey shall be carried out to confirm the validity of the approval. The implementation survey shall be carried by the *Register's* Surveyor within one year from the date of approval of the PMS.

During the implementation survey the following shall be verified by a Surveyor to insure:

- .1 The PMS is implemented according to the approval documentation and is adapted to the type and complexity of the components/systems on board.
- .2 The PMS is producing the documentation required for the Annual Audit and the requirements of surveys and testing for retention of class are complied with.
- .3 The onboard personnel are familiar with the PMS.

When this survey is carried out and the implementation is found in order, a report describing the PMS shall be submitted to the *Register* and the approved PMS may replace the CSM.

2.3.3.11 An Annual Audit is to be carried out to maintain the validity of PMS. An Annual Audit shall be carried out by a *Register's* Surveyor and preferably concurrently with the annual survey of machinery.

During the Annual Audit the following shall be verified by a Surveyor:

- .1 The Surveyor shall review the annual report or verify that it has been reviewed by the *Register*.
- .2 The purpose of this survey shall be to verify that the scheme is being correctly operated and that the machinery has been functioning satisfactorily since the previous

survey. A general examination of the items concerned shall be carried out.

- 3. The performance and maintenance records shall be examined to verify that the machinery has functioned satisfactorily since the previous survey or action has been taken in response of machinery operating parameters exceeding acceptable tolerances and the overhaul intervals have been maintained.
- 4. Written details of break-down or malfunction shall be made available.
- 5. Description of repairs carried out shall be examined. Any machinery part, which has been replaced by a spare one, due to damage, is to be retained on board-where possible-until examined by a *Register's* Surveyor.

Upon satisfactory completion of the above requirements, the *Register* shall retain the PMS.

2.3.3.12 The damage of components/machinery shall be reported to the *Register*. The repairs of such damaged components/machinery shall be carried out to the satisfaction of the Surveyor of the *Register*.

Any repair and corrective action regarding machinery under PMS system shall be recorded in the PMS log-book and repair verified by the Surveyor of the *Register* at the Annual Audit.

In the case of overdue outstanding conditions of class or a record of unprepared damage which would affect the PMS the relevant items shall be kept out of the PMS until the conditions of class are fulfilled or the repair is carried out.

2.3.3.13 The survey arrangement for machinery under PMS can be cancelled by the *Register* if PMS not being satisfactorily carried out either from the maintenance records or the general condition of the machinery, or when the agreed intervals between overhauls are exceeded, i.e. approval document will be withdrawn. The conditions for ordinary Continuous survey of machinery will then be introduced.

2.3.3.14 In case of sale or change of management of the vessel or transfer of class the *Register* will automatically cancel the approval document and the approval is to be reconsidered.

2.3.3.15 The ship Company may, at any time, cancel the survey arrangement for machinery under PMS by informing the *Register* in writing and for this case the items which have been inspected under the PMS since the last annual survey can be credited for class at the discretion of the attending Surveyor.

2.3.4 Condition Monitoring and Condition Based Maintenance

2.3.4.1 General

2.3.4.1.1 Application

2.3.4.1.1.1 These requirements apply to the approved Condition Monitoring and Condition Based Maintenance schemes where the condition monitoring results are used to influence the scope and/or frequency of Class survey.

2.3.4.1.1.2 This scheme may be applied to components and systems covered by Continuous Machinery Survey (CMS), and other components and systems as requested by the owner. The extent of Condition Based Maintenance and associated monitoring equipment to be included in the maintenance scheme is decided by the Owner.

2.3.4.1.1.3 These requirements can be applied only to vessels operating on approved PMS survey scheme.

2.3.4.1.1.4 The scheme may be applied to any individual items and systems. Any items not covered by the scheme shall be surveyed and credited in accordance with the requirements of 2.3.1 and/or 2.3.3.

2.3.4.1.2 Definitions

2.3.4.1.2.1 The following standard terms are defined in ISO 13372:2012:

- .1 **Condition monitoring:** acquisition and processing of information and data that indicate the state of a machine over time. The machine state deteriorates if faults or failures occur.
- .2 **Diagnostic:** examination of symptoms and syndromes to determine the nature of faults or failures.
- .3 **Condition Based Maintenance:** maintenance performed as governed by condition monitoring programmes.

2.3.4.1.3 Condition Monitoring (CM)

2.3.4.1.3.1 Where an approved condition monitoring system is fitted, credit for survey may be based on acceptable condition monitoring results. The condition monitoring results are to be reviewed during the annual audit.

2.3.4.1.3.2 Limiting parameters are to be based on the Original Equipment Manufacturers guidelines (OEM), or a recognised international standard.

2.3.4.1.3.3 The condition monitoring system is to provide an equivalent or greater degree of confidence in the condition of the machinery to traditional survey techniques.

2.3.4.1.3.4 The condition monitoring system shall be approved in accordance with the *Register's* procedures.

2.3.4.1.3.5 A condition monitoring system may be used to provide a greater understanding of equipment condition, and a condition-based maintenance scheme may be used to obtain maintenance efficiency. Class approval is required where owners wish to change the survey cycle based on CM/CBM.

2.3.4.1.3.6 Software systems can use complex algorithms, machine learning and knowledge of global equipment populations/defect data in order to identify acceptability for continued service or the requirement for maintenance. These systems may be independent of the OEM recommended maintenance and condition monitoring suggested limits. Approval of this type of software is to be based on OEM recommendations, industry standards and *Register's* experience.

2.3.4.1.3.7 The *Register* retains the right to test or open-up the machinery, irrespective of the CM results, if deemed necessary.

2.3.4.1.4 Condition Based Maintenance (CBM)

2.3.4.1.4.1 Where an owner wishes to base their equipment maintenance on a CBM approach, this is to meet the requirements of the ISM Code.

2.3.4.1.4.2 Where an agreed planned maintenance and CBM scheme is in operation, the CMS and other survey intervals may be extended based on OEM maintenance recommendations and acceptable condition monitoring results.

2.3.4.1.4.3 Limiting parameters (alarms and warnings) are to be based on the OEM guidelines, or a recognised international standard.

2.3.4.1.4.4 The CBM scheme is to provide an equivalent or greater degree of confidence in the condition of the machinery to traditional maintenance techniques.

2.3.4.1.4.5 The scheme shall be approved in accordance with the *Register's* procedures.

2.3.4.1.4.6 Software systems can use complex algorithms, machine learning and knowledge of global equipment populations/defect data in order to identify acceptability for continued service or the requirement for maintenance. These systems may be independent of the OEM recommended maintenance and condition monitoring suggested limits. Approval of this type of software is to be based on OEM recommendations, industry standards and *Register's* experience.

2.3.4.2 Procedures and Conditions for approval of CM and CBM

2.3.4.2.1 Onboard Responsibility

2.3.4.2.1.1 The chief engineer shall be the responsible person on board in charge of the CM and CBM.

2.3.4.2.1.2 Documentation on the overhaul of items covered by CM and CBM schemes shall be reported by the chief engineer.

2.3.4.2.1.3 Access to computerized systems for updating of the maintenance documentation and maintenance program shall only be permitted by the chief engineer or other authorized person.

2.3.4.2.1.4 All personnel involved in CM and CBM shall be appropriately qualified.

NOTE: CM does not replace routine surveillance or the chief engineer's responsibility for taking decisions in accordance with his judgement.

2.3.4.2.2 Equipment and System Requirements

2.3.4.2.2.1 CM equipment and systems shall be approved in accordance with a procedure of the *Register*.

2.3.4.2.2.2 The CM/CBM scheme and its extent, are to be approved by the *Register*.

2.3.4.2.2.3 The CBM scheme is to be capable of producing a condition report, and maintenance recommendations.

2.3.4.2.2.4 A system is to be provided to identify where limiting parameters (alarms and warnings) are modified during the operation of the scheme.

2.3.4.2.2.5 Where CM and CBM schemes use remote monitoring and diagnosis (i.e. data is transferred from the vessel and analysed remotely), the system is to meet the applicable

standards for Cyber Safety and Security. The system shall be capable of continued onboard operation in the event of loss of the communication function.

2.3.4.2.2.6 CBM schemes are to identify defects and unexpected failures that were not prevented by the CM system.

2.3.4.2.2.7 Systems shall include a method of backing up data at regular intervals.

2.3.4.2.3 Documentation and Information

2.3.4.2.3.1 The following documentation shall be made available to the *Register* for the approval of the scheme:

- .1 Procedure for changes to software system and CM parameters.
- .2 Listing of equipment to be included in the scheme.
- .3 Listing of acceptable condition monitoring parameters.
- .4 Description of CBM scheme.
- .5 Listing, specifications, and maintenance procedures for condition monitoring equipment.
- .6 Baseline data for equipment with condition monitoring.
- .7 Qualification of personnel and company responsible for analysing CM results.

2.3.4.2.3.2 In addition to the above documentation the following information shall be available on board:

- .1 All clauses in 2.3.4.2.3.1 in an up-to-date fashion.
- .2 Maintenance instructions (manufacturer's and shipyard's).
- .3 Condition monitoring data including all data since last opening of the machine and the original base line data.
- .4 Reference documentation (trend investigation procedures, etc.).
- .5 Records of maintenance including repairs and renewals carried out.
- .6 Records of changes to software systems and parameters.
- .7 Sensors calibration records / certification / status.

2.3.4.2.4 Approval validity

2.3.4.2.4.1 An Annual Audit shall be carried out to maintain the validity of the CM/CBM scheme.

2.3.4.2.4.2 The survey arrangement for machinery under CM/CBM can be cancelled by the *Register* if the scheme is not being satisfactorily carried out either from the maintenance records or the general condition of the machinery.

2.3.4.2.4.3 The case of sale or change of management of the ship or transfer of class shall cause the approval to be reconsidered.

2.3.4.2.4.4 The ship owner may, at any time, cancel the survey arrangement for machinery under the scheme by informing the *Register* in writing and for this case the items which have been inspected under the scheme since the last annual Audit can be credited for class at the discretion of the attending surveyor.

2.3.4.3 Surveys

2.3.4.3.1 Installation Survey

2.3.4.3.1.1 Condition monitoring equipment is to be installed and surveyed in accordance with the Rules of the *Register*, and a set of base line readings is to be taken.

2.3.4.3.2 Implementation Survey

2.3.4.3.2.1 The Implementation Survey shall be carried out by the *Register's* surveyor no earlier than 6 months after installation survey and no later than the first class annual survey.

2.3.4.3.2.2 During the Implementation survey the following shall be verified by a surveyor:

- .1 the CM/CBM scheme is implemented according to the approval documentation, including a comparison with baseline data,
- .2 the scheme is producing the documentation required for the Annual Audit and the requirements of surveys and testing for the maintenance of class are complied with,
- .3 the onboard personnel are familiar with operating the scheme,
- .4 records of any limiting parameters (alarms and warnings) that have been modified during the operation of the scheme,
- .5 Records of any failures of monitored equipment are to be reviewed to ensure that the condition monitoring scheme is effective / sufficient.

2.3.4.3.2.3 When this survey is carried out and the implementation is found in order, a report describing the scheme shall be submitted to the *Register* and the scheme may be put into service.

2.3.4.3.3 Annual Audit

2.3.4.3.3.1 An annual audit of the CM and CBM scheme shall be carried out by a *Register's* surveyor concurrently with the Class annual survey.

2.3.4.3.3.2 The purpose of this audit shall be to verify that the scheme is being correctly operated and that the machinery has been functioning satisfactorily since the previous audit. This is to include any limiting parameters (alarms and warnings) that have been modified since the last audit. A general examination of the items concerned shall be carried out.

2.3.4.3.3.3 The performance, condition monitoring and maintenance records shall be examined to verify that the machinery has functioned satisfactorily since the previous survey, or action has been taken in response to machinery operating parameters exceeding acceptable tolerances.

2.3.4.3.3.4 Written details of break-down or malfunction shall be made available.

2.3.4.3.3.5 At the discretion of the surveyor, function tests, confirmatory surveys and random check readings, where Condition Monitoring / Condition Based Maintenance equipment is in use, shall be carried out as far as practicable and reasonable.

2.3.4.3.3.6 The familiarity of the chief engineer and other personnel involved with the CM system shall be verified.

2.3.4.3.3.7 Calibration status of sensors and equipment shall be verified.

2.3.4.3.3.8 Verification that the suitability of the CM/CBM scheme has been reviewed following defects and failures shall be carried out.

2.3.4.3.4 Damage and repairs

2.3.4.3.4.1 Damage to components or items of machinery is to be reported to the *Register*. The repairs of such damaged components or items of machinery are to be carried out to the satisfaction of the Surveyor.

2.3.4.3.4.2 Details of repairs and maintenance carried out shall be examined. Any machinery part, which has been replaced by a spare one, due to damage, is to be retained on board where possible until examined by the *Register's* Surveyor.

2.3.4.3.4.3 Defect and failure data is to be reviewed in order to ensure the system output is appropriate. Where necessary, and following review of the failure data, there is to be a method of amending the CM and CBM scheme.

2.3.5 Surveys of vessels out of commission (lay-up vessels)

2.3.5.1 It is the responsibility of the Company to notify the *Register* when the vessel is laid-up, or otherwise taken out of service for a period more than three (3) months. Such notification is to be made in written.

2.3.5.2 The Company shall decide, depending on the foreseen duration of laid-up period, on the lay-up condition ("Hot" or "Cold" lay-up condition). Such foreseen lay-up period, with proposed lay-up condition is to be communicated in written to the *Register* also.

2.3.5.3 In order to maintain class during lay-up period the following surveys are required to be carried out:

- .1 Annual survey every 12 months from the starting date of their lay-up condition, in the scope agreed with the *Register* for each particular vessel depending on its lay-up condition.
- .2 Machinery, arrangements, and components in use (to be surveyed as normally required by the Rules).

The following survey requirements are to be followed:

1. Manned vessels during lay-up period shall comply with class requirements regarding fire safety (requirements may be limited to certain areas only, if such arrangement is specifically agreed with the *Register*).
- .2 As long as regular and agreed surveys during lay-up period are conducted to the satisfaction of the *Register* there is no time limit for how long a vessel can be laid-up.

2.3.5.4 Scope of **re-commissioning survey** of a laid-up vessel depends on several factors, such as time in lay-up, maintenance and preservation measures taken during lay-up, survey status at the time of re-commissioning, reason for re-commissioning (such as, but not limited to: single voyage for

scrap, single voyage to repair yard, etc.), age and the type of a vessel.

For vessels which have been laid-up for a period **up to 12 months**, an occasional survey is to be carried out, covering imminently due and overdue surveys, only. In addition to that, a visual inspection of other class related items, not covered by previous requirement, may be required when and if found necessary by the attending Surveyor.

For vessels which have been laid-up for a period **more than 12 months**, an occasional survey is to be carried out, covering all imminently due and overdue surveys. In addition to that a sea trial for functional testing of the machinery installation is to be carried out also. The scope of survey may be additionally increased if deemed necessary by the attending Surveyor (e.g. in case of longer lay-up periods with no preservation measures or maintenance).

In cases where the vessel has been laid up or has been out of service for a considerable period because of a major repair or modification and the owner elects to only carry out the overdue surveys, the next period of class will start from the expiry date of the Renewal survey. If the owner elects to carry out the next due Renewal survey, the period of class will start from the survey completion date.

2.3.5.5 For additional statutory requirements special instructions from the relevant Flag State Administration, or from local Port State authorities shall apply.

2.4 BOTTOM SURVEY

2.4.1 Docking survey

2.4.1.1 For all steel ships, except for passenger ships, there should be a minimum of two inspections of the outside of the ship's bottom during each five-year period of validity of the Certificate of Class / Cargo Ship Safety Construction Certificate, or when applicable during period of validity of safety certificates for non-SOLAS size vessels or vessels not performing international voyages (e.g. Certificate on the ship's ability for navigation). Inspection of the outside of ship's bottom should normally be carried out with the ship in a dry dock. However, consideration may be given to alternate examination while the ship is afloat as an In-water Survey, subject to provisions of 2.4.2. Special consideration is to be given to ships of 15 years or over before being permitted to have such examinations. For ESP ships exceeding of 15 years of age and over, such examinations are to be carried out with the ship in dry dock.

A minimum of two inspections of the outside of the ships bottom are to be carried out during the renewal period of five years and the intervals between any two inspections shall not exceed 36 months.

An extension of examination of the ship's bottom of 3 months beyond the due date can be granted in exceptional circumstances (see the *Rules for the classification of ships, Part 1 – General requirements, Chapter 1 – General information, 5.5.1*).

"Exceptional circumstances" means unavailability of dry-docking facilities; unavailability of repair facilities; unavailability of essential materials, equipment, or spare parts; or delays incurred by action taken to avoid severe weather conditions".

Flag State Administrations may give consideration to alternate inspections being carried out with the ship afloat through Pilot Extended Dry-Docking (EDD) schemes which extend the interval between surveys in dry-dock. Qualifying ships may be permitted to carry out two consecutive in-water surveys, subject to the conditions determined by the *Register* and agreed through tripartite projects between the Owner, Flag State Administration and the *Register*. Acceptance into such a Pilot scheme is subject to the formal written agreement with the ship's Flag State Administration including any additional specific Flag State Administration requirements.

The following ships and ship types are not eligible for the EDD scheme described in these guidelines:

- passenger ships,
- ships subject to the Enhanced Survey Program (ESP),
- general dry cargo ships,
- ships fitted with propulsion thrusters,
- ships where the propeller connection to the shaft is by means of a keyed taper,
- High Speed Craft (HSC).

Ships eligible for the EDD scheme are to meet following provisions and conditions:

- the ship should comply with the In-Water Survey provisions,
- protective coating in double bottom/double side ballast tanks, void spaces, and all other spaces adjacent to the shell should be maintained in GOOD condition,
- the shafting arrangement should fulfil the requirements for Tailshaft Condition Monitoring Survey Arrangement,
- hull maintenance scheme is to be implemented in accordance with ISM requirements.

NOTE: Notwithstanding the above stated, in case of dually classed vessels, EDD is to be additionally agreed with the other classification society. When, for the dually classed vessel, the Pilot Extended Dry-docking (EDD) has already been agreed by the other classification society, Register may accept requirements which differ from the ones listed above, while the prerogative to obtain the consent from the Owner and the Flag State Administration on the EDD remains to be applicable.

2.4.1.2 For cargo ships with $GT \geq 500$ one of two Docking surveys is to be carried out on or after the fourth annual survey in conjunction with the renewal of the Cargo Ship Safety Construction Certificate or when applicable Certificate on the ship's ability for navigation.

2.4.1.3 For survey requirements of ships made of wood, aluminium alloys and reinforced plastics *Rules for technical supervision of ships made of wood, aluminium alloys and reinforced plastics* shall apply.

2.4.1.4 For survey requirements of fishing vessels *Rules for statutory certification of fishing vessels* shall apply.

2.4.1.5 For passenger ships an inspection of the ship's bottom is required annually. In a five-year class period, two of such inspections are to take place out of water. The maximum interval between these inspections is 36 months. IWS may be carried out each year when an inspection out of water is not required. For ships older than 15 years, performance of IWS is subjected to special consideration and approval of the *Register*.

2.4.1.6 For passenger ships up to 15 years of age, other than ro-ro passenger ships, and where acceptable to Flag State Administration, the minimum number of docking surveys (inspections in dry-dock of the outside of bottom) in any five-year period of class may be reduced from two to one. In such cases the interval between consecutive inspections in dry dock should not exceed 60 months.

2.4.1.7 For passenger ships made of steel and not engaged in international voyages (area of navigation **5** to **8**) and up to 12 years of age, the docking survey may be carried out as specified in 2.4.1.1, or as specified in 2.4.1.6., based on the special consideration of the *Register*.

2.4.1.8 Time intervals and due dates for Docking surveys are given in Table 6.1-1, and extent of requirements in 6.

2.4.1.9 If the Society with which the vessel is dually classed with, applies different intervals for dry-docking surveys the *Register* may apply the requested interval of that Society.

2.4.1.10 In the case when the Flag State Administration applies different periodicity of dry-docking survey for passenger ships not performing international voyages, the *Register* may consider application of such periodicity in lieu of above requirements.

2.4.2 In-water survey

2.4.2.1 In-water survey of the ship's bottom in lieu of every second Docking survey required in 2.4.1 may normally be carried out on ships:

- .1 For which company provides statement confirming that the ship's bottom sustained no damages during the last period.
- .2 Where notation **IWS** has been assigned, except for the vessels in national navigation for which, instead of **IWS** notation, *Register* considers acceptability of items .1, .4 and .5 of 2.4.2.2.
- .3 When the bottom survey is not held concurrently with Initial or Renewal survey of relevant certificate mentioned in 2.4.1.2.
- .4 Where the previous bottom survey was carried out in dock (except for passenger ships, see 2.4.1.5).
- .5 Where no conditions of class exist requiring repair work to be carried out to the underwater part of the hull, rudder, propeller shaft or propeller.

NOTE: For ships older than 15 years (other than bulk carriers and tankers), performance of this survey is subjected to special consideration and approval of the *Register*. For tankers and bulk carriers of 15 years of age and over, inspection of the outside of the ship's bottom is to be carried out with the ship in dry dock.

For additional requirements for the assignment and maintenance of IWS notation refer to the *Rules for the classification of ships, Part 1 – General requirements, Chapter 6 – Requirements for additional class notations*, Section 6.

2.4.2.2 The In-water survey is to provide information normally obtained from the Docking survey. Special consideration shall be given to ascertaining rudder bearing clearances and stern bush clearances of oil stern bearings based on a review of the operating history, on board testing and stern oil sample reports. These considerations are to be included in the proposal for in-water survey which are to be submitted in ad-

vance of the survey so that satisfactory arrangements can be agreed with the *Register*.

2.4.2.3 Conditions and requirements for performing In-water Survey are specified in 6.3.

2.5 SURVEY OF PROPELLERS AND PROPELLER SHAFTS

2.5.1 For type and periodicity of surveys of propellers and propeller shafts see requirements stated in 10.

2.6 OTHER SURVEYS

2.6.1 Occasional surveys

2.6.1.1 Occasional survey is obligatory survey of the ship in the following cases:

- .1 If the ship sustains accident, calamity, or damage of such extent that it is presumed that the ability for navigation of the ship is endangered.
- .2 When repairs or renewals of the hull, machinery installations and equipment are performed.
- .3 When periodical surveys are delayed or postponed as prescribed by the Rules.
- .4 On re-commissioning survey after the ship has been laid-up.
- .5 When temporary changing navigation area or purpose of the ship.
- .6 In the cases when occasional surveys are demanded by the *Register* as addition to the periodical surveys.

2.6.2 Voyage repairs and maintenance

2.6.2.1 Where repairs to hull, machinery installation or equipment, which affect or may affect classification, are to be carried out by a riding crew during a voyage they are to be planned in advance. A complete repair procedure including the extent of proposed repair and the need for the Surveyor's attendance during the voyage is to be submitted to and agreed upon by the *Register* reasonably in advance.

Failure to notify the *Register*, in advance of the repairs, may result in suspension of the ship's class (see also the *Rules for the classification of ships, Part 1 - General requirements, Chapter 1 – General information, 1.5.6*).

Where in any emergency circumstance, emergency repairs are to be effected immediately, the repairs should be documented in the ship's log and submitted thereafter to the *Register* for use in determining further survey requirements.

The above is not intended to include maintenance and overhaul to hull, machinery installation and equipment in accordance with manufacturer's recommended procedures and established marine practice and which does not require the *Register's* approval.

However, any repair as a result of such maintenance and overhauls which affects or may affect classification

is to be noted in the ship's log and submitted to the attending Surveyor for use in determining further survey requirements.

3 PREPARATIONS, CONDITIONS AND DOCUMENTATION FOR SURVEY

3.1 SURVEY PROGRAMME FOR SHIPS WITH AFFIXED ESP NOTATION

3.1.1 The Company in co-operation with the *Register* is to work out a specific Survey Programme for bulk carriers and tankers on which Enhanced Survey Programme is applied (ships with affixed **ESP** notation) prior to the commencement of any part of:

- the Renewal Survey, or
- the Intermediate Survey for vessels over **10** years of age.

The Survey Programme is to be in written format. The Survey Programme at Intermediate Survey may consist of the Survey Programme at the previous Renewal Survey supplemented by the Executive Hull Summary of that Renewal Survey and later relevant survey reports.

Prior to the development of the survey programme, the survey planning questionnaire is to be completed by the owner and forwarded to the *Register*.

The Survey Programme at Intermediate Survey may consist of the Survey Programme at the previous Renewal Survey supplemented by the Executive Hull Summary of that Renewal Survey and later relevant survey reports.

The Survey Programme is to be worked out, taking into account any amendments to the survey requirements implemented after the last Renewal Survey carried out.

3.1.2 The Survey Programme is to include the proposals for survey, including the means for providing access for Close-up survey, thickness measurement and tank testing and should take into account the information detailed in 3.3.

3.1.3 While developing the Survey Programme, in all cases, requirements concerning Close-up survey and thickness measurement stated in Tables 7.2.1-3, 7.2.1-3a, 7.7.4-1, 7.7.4-2, 7.7.2-1, 7.7.2-2, 7.7.2-3 and 7.2.2-1 are to be conducted as a minimum.

3.1.4 In developing the Survey Programme, the following documentation is to be collected and consulted with a view to selecting tanks, areas, and structural elements to be examined:

- .1 Survey status and basic ship information.
- .2 Documentation on board (as described in 3.3).
- .3 Main structural plans (scantling drawings), including information regarding use of high tensile steels (HTS).
- .4 Executive Hull Summary.
- .5 Relevant previous damage and repair history.
- .6 Relevant previous survey and inspection reports from both the *Register* and the Company.
- .7 Cargo and ballast history for the last three (3) years, including carriage of cargo under heated conditions.

- .8 Details of the inert gas plant and tank cleaning procedures.
- .9 Information and other relevant data regarding conversion or modification of the ship's cargo and ballast tanks since the time of construction.
- .10 Description and history of the coating and corrosion protection system (previous class notation), if any.
- .11 Inspections by the Owner's personnel during the last 3 years with reference to structural deterioration in general, leakage in tank boundaries and piping and condition of the coating and corrosion protection system if any.
- .12 Information regarding the relevant maintenance level during operation including port state control reports of inspection containing hull related deficiencies, Safety Management System non-conformities relating to hull maintenance, including the associated corrective action(s), and
- .13 Any other information that will help identify suspect areas and critical structural areas.

3.1.5 The submitted Survey Programme is to account for and comply, as a minimum, with the requirements for Close-up survey, thickness measurement and tank testing, and is to include relevant information including at least:

- .1 Basic ship information and particulars.
- .2 Main structural plans (scantlings drawings), including information regarding use of high tensile steels (HTS).
- .3 Plan of holds and tanks.
- .4 List of holds and tanks with information on use, corrosion prevention and condition of coating.
- .5 Conditions for survey (e.g. information regarding hold and tank cleaning, gas freeing, ventilation, lighting).
- .6 Provisions and methods for access to structures.
- .7 Equipment for surveys.
- .8 Nomination of holds and tanks and areas for Close-up survey.
- .9 Nominations of sections for thickness measurement.
- .10 Nomination of tanks for tank testing.
- .11 Damage experience related to the ship in question.

The *Register* will advise the Company of the maximum acceptable structural corrosion diminution levels applicable to the ship.

3.1.6 There are three basic types of possible failures to be considered in connection with development of a Survey Programme: corrosion, cracks and buckling. Contact damages, however, would not normally be covered by the program as indents are usually dealt with as a normal routine by Surveyors.

The development of a Survey Programme should in principle be as shown schematically in Figure 3.1-1. The approach is based on an evaluation of experience and knowledge basically related to:

- .1 The structural design, where it should be considered with respect to structural details which may be susceptible to buckling or cracking as a result of vibration, high stress levels or fatigue.
- .2 Corrosion, related to the age of a ship, and is closely connected with the quality of the corrosion prevention system and subsequent maintenance during service life. Corrosion may also lead to cracking and / or buckling.

3.1.7 The various tanks, holds and spaces should be listed with the corrosion risks nominated accordingly. On the basis of the table of corrosion risk and the evaluation of design experience, the locations for initial Close-up survey and thickness measurement may be nominated.

3.1.8 The sections subjected to thickness measurement should normally be nominated in tanks, holds, and spaces where corrosion risk is judged to be the highest.

For other requirements related to thickness measurement see 7.5.

3.1.9 The nomination for tanks, holds, and spaces for Close-up survey should, initially be based on highest corrosion risk, and should always include ballast tanks. The principle for the selection should be that the extent is increased by age or where information is insufficient or unreliable.

For other requirements related to Close-up survey see 7.6.

3.1.10 However, these guidelines may not be used to reduce the requirements pertaining to thickness measurement and Close-up survey contained in 3.1.3, which are, in all cases, to be complied with as a minimum.

3.1.11 Survey meeting

3.1.11.1 Proper preparation and close co-operation between the attending surveyor(s) and the owner's representatives onboard prior to and during the survey are an essential

part in the safe and efficient conduct of the survey. During the survey on board safety meetings are to be held regularly.

Prior to the commencement of any part of the Renewal and Intermediate Survey a survey meeting is to be held between the attending Surveyor(s), the Owner's Representative in attendance and the TM firm representative, where involved, and the master of the ship or an appropriately qualified representative appointed by the master or Company for the purpose to ascertain that all the arrangements envisaged in the survey programme are in place, so as to ensure the safe and efficient conduct of the survey work to be carried out.

3.1.11.2 The following is an indicative list of items that are to be addressed in the meeting:

- .1 schedule of the vessel (i.e. the voyage, docking and undocking manoeuvres, periods alongside, cargo and ballast operations, etc.),
- .2 provisions and arrangements for thickness measurements (i.e. access, cleaning/descaling, illumination, ventilation, personal safety),
- .3 extent of the thickness measurements,
- .4 acceptance criteria (refer to the list of minimum thickness'),
- .5 extent of close-up survey and thickness measurement considering the coating condition and suspect areas/areas of substantial corrosion,
- .6 execution of thickness measurements,
- .7 taking representative readings in general and where uneven corrosion/pitting is found,
- .8 mapping of areas of substantial corrosion, and
- .9 communication between attending Surveyor(s) the thickness measurement firm operator(s) and owner representative(s) concerning findings.

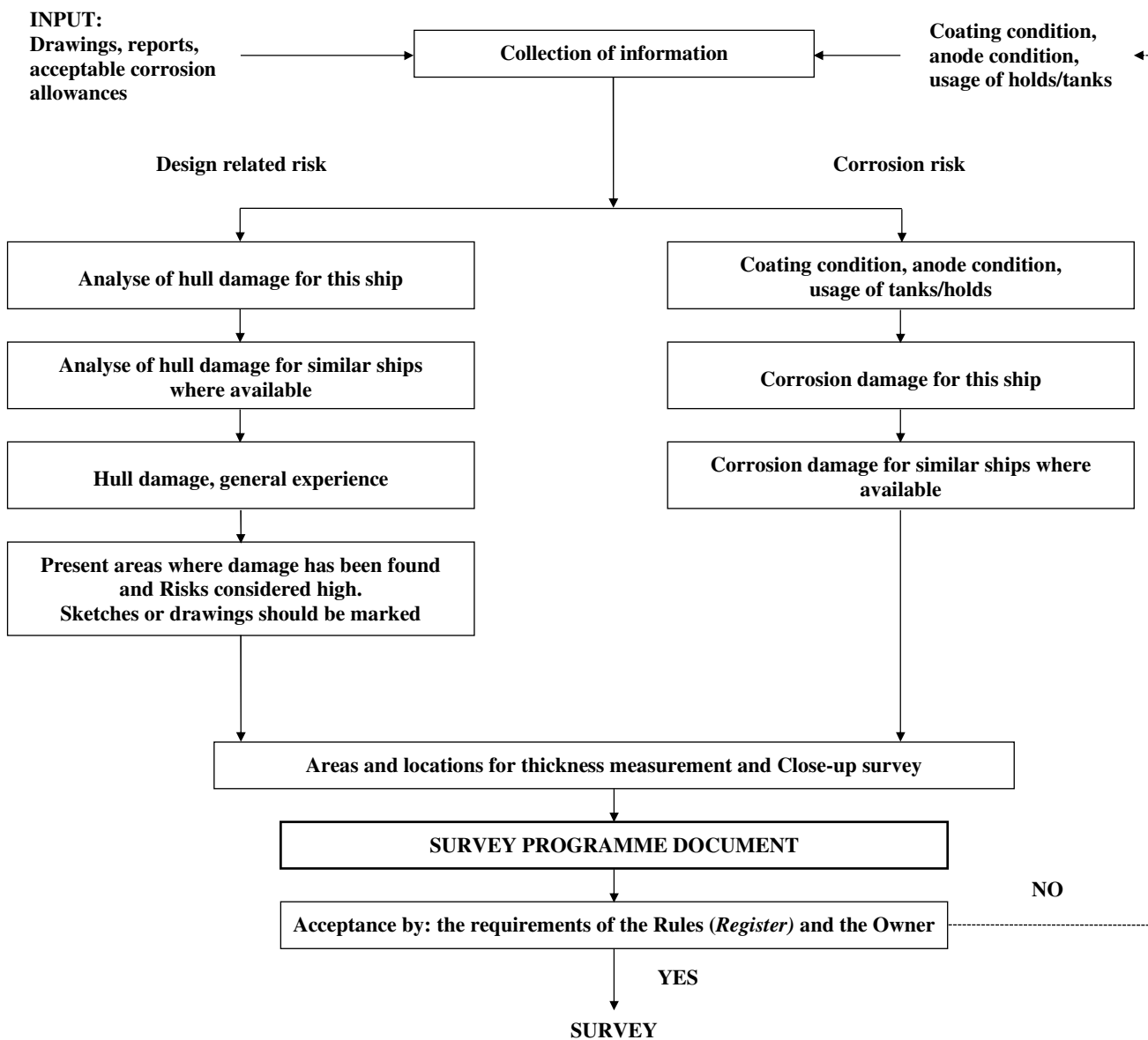

Figure 3.1-1
Scheme of development of Survey Programme document

3.2 PREPARATIONS AND CONDITIONS FOR SURVEY – ALL SHIPS

3.2.1 The Company is to provide the necessary facilities for a safe execution of the survey.

In order to enable the attending Surveyors to carry out the survey, provisions for proper and safe access are to be agreed between the owner and the *Register* and are to be in accordance with IACS PR37.

Details of the means of access are to be provided in the survey planning questionnaire.

In cases where the provisions of safety and required access are judged by the attending Surveyors not to be adequate, the survey of the spaces involved is to not proceed.

NOTE: For additional requirements related to safety of Surveyors the following may be considered also (as far as applicable): IACS Recommendation 91 - "Guidelines for acceptance / approval of alternative means of access", IACS Recommendation 78 - "Safe use of portable ladders for close-up survey", IACS Recommendation 72 - "Confined space safe practice", 72, IMO Res. A.1050(27), EU Directive 2001/45/EC, amending Council Directive 89/655/EEC concerning the minimum safety and health requirements for the use of work equipment by workers at work.

When in any doubt about the safety associated with the confined space, the attending surveyor has the right to refuse entry.

3.2.2 Cargo holds, tanks and spaces are to be safe for access. Cargo holds, tanks and spaces are to be gas free and properly ventilated. Prior to entering a tank, void, or enclosed space, it is to be verified that the atmosphere in the tank is free from hazardous gas and contains sufficient oxygen.

In preparation for survey and thickness measurements and to allow for a thorough examination, all spaces are to be cleaned including removal from surfaces of all loose accumulated corrosion scale. Spaces are to be sufficiently clean and free from water, scale, dirt, oil residues etc. to reveal corrosion, deformation, fractures, damages, or other structural deterioration. However, those areas of structure whose renewal has already been decided by the Company need only to be cleaned and descaled to the extent necessary to determine the limits of areas to be renewed.

Sufficient illumination is to be provided to reveal corrosion, deformation, fractures, damages, or other structural deterioration.

Where soft or semi-hard coating have been applied, safe access is to be provided for the Surveyor to verify the effectiveness of the coating and to carry out an assessment of the conditions of internal structures which may include spot removal of the coating. When safe access cannot be provided, the soft or semi-hard coating is to be removed.

The establishment of proper preparation and the close co-operation between the attending surveyor(s) and the Company's representatives onboard prior to and during the survey are an essential part in the safe and efficient conduct of the survey.

Applicable safety procedures and responsibilities shall be discussed and agreed to ensure that the survey is carried out under controlled conditions. Safety Meetings shall be held prior to entering the tank or space and regularly during the survey on board.

3.2.3 Casings, ceilings or linings, and loose insulation, where fitted, are to be removed, as required by the Surveyor, for examination of plating and framing. Compositions on plating are to be examined and sounded but need not be disturbed if found adhering satisfactorily to the plating.

In refrigerated cargo spaces the condition of the coating behind the insulation is to be examined at representative locations. The examination may be limited to verification that the protective coating remains effective and that there are no visible structural defects. Where POOR coating condition is found, the examination is to be extended as deemed necessary by the Surveyor. The condition of the coating is to be reported. If indents, scratches, etc., are detected during surveys of shell plating from the outside, insulation's in way are to be removed as required by the Surveyor, for further examination of the plating and adjacent frames.

3.2.4 For overall survey, means are to be provided to enable the Surveyor to examine the hull structure in a safe and practical way.

For close-up survey, in a cargo holds, cargo tanks and ballast tanks, one or more of the following means for access, acceptable to the Surveyor, is to be provided:

- .1 Permanent staging and passages through structures.
- .2 Temporary staging and passages through structure.
- .3 Hydraulic arm vehicles such as conventional cherry pickers, lifts, and movable platforms.
- .4 Boats or rafts.
- .5 Portable ladders.
- .6 Other equivalent means.

For close-up surveys of the cargo hold shell frames of bulk carriers less than 100.000 DWT, one or more of the following means for access, acceptable to the Surveyor, is to be provided:

- .1 Permanent staging and passages through structures.
- .2 Temporary staging and passages through structures.
- .3 Portable ladder restricted to not more than 5 m in length may be accepted for surveys of lower section of a shell frame including bracket.
- .4 Hydraulic arm vehicles such as conventional cherry pickers, lifts and movable platforms.
- .5 Boats or rafts; provided the structural capacity of the hold is sufficient to withstand static loads at all levels of water.
- .6 Other equivalent means.

For close-up surveys of the cargo hold shell frames of bulk carriers 100.000 DWT and above, the use of portable ladders is not accepted, and one or more of the following means for access, acceptable to the Surveyor, is to be provided:

Annual Surveys, Intermediate Survey under 10 years of age and Renewal Survey No. 1

- .1 Permanent staging and passages through structures.
- .2 Temporary staging and passages through structures.

- .3 Hydraulic arm vehicles such as conventional cherry pickers, lifts, and movable platforms.
- .4 Boats or rafts provided the structural capacity of the hold is sufficient to withstand static loads at all levels of water.
- .5 Other equivalent means.

Subsequent Intermediate Surveys and Renewal Surveys:

- .1 Either permanent or temporary staging and passage through structures for close-up survey of at least the upper part of hold frames.
- .2 Hydraulic arm vehicles such as conventional cherry pickers for surveys of lower and middle part of shell frames as alternative to staging.
- .3 Hydraulic arm vehicles such as conventional cherry pickers, lifts and movable platforms.
- .4 Boats or rafts provided the structural capacity of the hold is sufficient to withstand static loads at all levels of water.
- .5 Other equivalent means.

Notwithstanding the above requirements, the use of a portable ladder fitted with a mechanical device to secure the upper end of the ladder is acceptable for the *"close-up examination of sufficient extent, minimum 25% of frames, to establish the condition of the lower region of the shell frames including approx. lower one third length of side frame at side shell and side frame end attachment and the adjacent shell plating of the forward cargo hold"* at Annual Survey, required in 3.2.4.1.b, and the *"one other selected cargo hold"* required in 3.2.4.2.b.

3.2.5 Thickness measurements

The thickness measurements are to be carried out by a qualified firm approved either by the Register, or by the recognised classification society (see also the *Rules for the classification of ships, Part 1 - General requirements, Chapter 4 - Approval of manufacturers and service suppliers*, 4, 2), except that in respect of measurements of non-ESP ships less than 500 GT, the Register may disregard some requirements of the *Rules for the classification of ships, Part 1 - General requirements, Chapter 4 - Approval of manufacturers and service suppliers* for approval of firms for such thickness measurements.

Thickness measurements required in context of hull structural surveys if not carried out by the *Register* are to be witnessed by a Surveyor. The attendance of the surveyor shall be recorded. This requires the Surveyor to be on board, while the gauging is taken, to the extent necessary to control the process. It is confirmed that this also applies to thickness measurements taken during voyages.

Prior to the commencement of any part of the survey a survey meeting is to be held between the attending Surveyor(s), the Company's Representative in attendance and the TM firm representative so as to ensure the safe and efficient execution of the surveys and thickness measurements to be carried out onboard.

Requirements for the thickness measurement process are also defined in 7.5.

Thickness measurement is normally to be carried out by means of ultrasonic test equipment. The accuracy of the equipment is to be proven to the Surveyor as required.

In any kind of survey, i.e. special, intermediate, annual or other surveys having the scope of the foregoing ones, thickness measurements, of structures in areas where close-up surveys are required are to be carried out simultaneously with close-up surveys.

Consideration may be given by the attending Surveyor to allow use of Remote Inspection Techniques (RIT) as an alternative to close-up survey. Surveys conducted using a RIT are to be completed to the satisfaction of the attending Surveyor. When RIT is used for a close-up survey, temporary means of access for the corresponding thickness measurements is to be provided unless such RIT is also able to carry out the required thickness measurements.

For structure built with a material other than steel, alternative thickness measurement requirements may be developed and applied as deemed necessary (see 7.2.4.1 for aluminium).

In all cases the extent of thickness measurements is to be sufficient as to represent the actual average condition.

When a survey is split between different survey stations, a report is to be made for each portion of the survey. A list of items examined and / or tested (pressure testing, thickness measurement etc.) and an indication of whether the item has been credited, are to be made available to the next attending Surveyor(s), prior to continuing or completing the survey.

3.2.6 Thickness measurements Acceptance Criteria

The acceptance criteria for thickness measurements are according to the Rules of the individual Classification Society and/or specific IACS URs depending on ship's age and structural elements concerned, e.g. UR S18 ¹⁾ for corrugated transverse bulkhead, UR S21 ³⁾ or UR S21A ²⁾ for all cargo hatch covers and coamings on exposed decks.

NOTES:

- ¹⁾ UR S18 Revision 10, or subsequent revisions or corrigenda as applicable.
- ²⁾ UR S21A applies for ships contracted for construction on or after 1 July 2012, while the Revision 1 of UR S21A applies for ships contracted for construction on or after 1 July 2016. UR S21A was withdrawn from 1 July 2024 and replaced by UR S21 Revision 6.
- ³⁾ UR S21 Revision 6 applies for ships contracted for construction on or after 1 July 2024.

3.2.7 Remote Inspection Techniques (RIT)

The RIT is to provide the information normally obtained from a close-up survey. RIT surveys are to be carried out in accordance with the requirements given here-in and the requirements of IACS Recommendation 42 "Guidelines for Use of Remote Inspection Techniques for surveys".

These considerations are to be included in the proposals for use of a RIT which are to be submitted for the review of the *Register* in advance of the survey, so that satisfactory arrangements can be agreed with the *Register*.

The equipment and procedure for observing and reporting the survey using a RIT are to be discussed and agreed with the parties involved prior to the RIT survey, and

suitable time is to be allowed to set-up, calibrate and test all equipment beforehand.

When using a RIT as an alternative to close-up survey, if not carried out by the *Register* itself, it is to be conducted by a firm approved as a service supplier according to IACS UR Z17 and is to be witnessed by an attending surveyor of the *Register*.

The structure to be examined using a RIT is to be sufficiently clean to permit meaningful examination. Visibility is to be sufficient to allow for a meaningful examination.

The *Register* is to be satisfied with the methods of orientation on the structure.

The Surveyor is to be satisfied with the method of data presentation including pictorial representation, and a good two-way communication between the Surveyor and RIT operator is to be provided.

If the RIT reveals damage or deterioration that requires attention, the Surveyor may require traditional survey to be undertaken without the use of a RIT.

3.2.8 One or more of the following fracture detection procedures may be required if deemed necessary by the Surveyor:

- .1 Radiographic equipment testing.
- .2 Ultrasonic equipment testing.
- .3 Magnetic particle equipment testing.
- .4 Dye penetrant testing.

Explosimeter, oxygen-meter, breathing apparatus, lifelines, riding belts with rope and hook and whistles together with instructions and guidance on their use are to be made available during the survey. A safety checklist is to be provided.

Adequate and safe lighting is to be provided for the safe and efficient conduct of the survey.

Adequate protective clothing is to be made available and used during the survey (e.g. safety helmet, gloves, safety shoes).

3.2.9 Remote surveys (survey without surveyor's attendance onboard)

3.2.9.1 Following surveys may be performed as a remote survey upon the request from the owner and upon consideration of the *Register*:

- .1 Postponement, issuance, deletion of Condition of Class, including: follow-up surveys (e.g. deletion/revision of a condition of class),
- .2 Postponement of Class surveys (Auxiliary Boiler extension survey (up to 3-months), Tail Shaft or Tube Shaft survey (up to 3-month extension) and other),
- .3 Items of Continuous Survey for Machinery (refer to IACS UR Z18) or Planned Maintenance Scheme (refer to IACS UR Z20) - items credit or extension,
- .4 Occasional survey for change of ship's name,
- .5 Occasional survey for loss of anchor,
- .6 Occasional survey for minor machinery or equipment damage,
- .7 Occasional survey for minor hull damage,

- .8 Occasional survey for minor deficiencies/defects not subject to a Condition of Class,
- .9 In-water bottom survey,
- .10 Specified items of a class periodical survey (excluding additional specific items of initial or renewal surveys), including completion of remaining items of a part held class periodical survey,
- .11 Non-propelled/ un-manned barges/pontoon - annual surveys when no survey of hull compartments is due,
- .12 Minor retrofit/installation/upgrade of equipment,
- .13 Documentary or data based initial/ periodical/renewal/ occasional verifications and surveys,
- .14 Lay-up class survey.

The following statutory related surveys may also be conducted as remote surveys, either under general authorization from the Flag State Administration, or on the case-by-case basis, if the Flag State Administration requires:

- .1 Postponement, issuance, deletion of statutory recommendations,
- .2 Lay-up statutory survey,
- .3 Change of Concurrent Load Line,
- .4 Inventory of Hazardous Materials (IHM).

Surveys outside the aforementioned scope (upon the request from the owner) may be performed as a remote survey, depending on case-by-case analysis of the *Register* and if applicable subjected to prior specific or general authorization and by following specific instructions of the Flag State Administration (if any).

3.2.10 Confined Space Entry Procedures & Rescue and emergency response equipment

3.2.10.1 The atmosphere has to be demonstrated as being safe (safe limits for entry are atmospheric oxygen the range of 20.6% to 22% by volume, combustible gases not more than 1% of lower flammable limit, toxic vapours and gases not more than 50% of the occupational exposure limits).

3.2.10.2 Adequate ventilation arrangements are to be in place and functioning throughout the period the surveyors are inside the confined space.

3.2.10.3 Adequate emergency response arrangements are to be in place to ensure that appropriate rescue equipment is made available at the entrance of the confined space. Understanding that rescue in a confined space can be time critical, if a confined space is such that rescue will be extremely difficult using available equipment, surveyors shall refuse entry until the risk can be mitigated to an acceptable level.

3.2.10.4 If breathing apparatus and/or other equipment is used as "Rescue and emergency response equipment" then it is recommended that the equipment should be suitable for the configuration of the space being surveyed.

3.2.11 Survey at sea or at anchorage

3.2.11.1 Survey at sea or at anchorage may be accepted if the Surveyor is provided with the necessary assistance from

the personnel on board. Necessary precautions and procedures for carrying out the survey are to be in accordance with the following:

3.2.11.2 A communication system is to be arranged between the survey party in the tank and the responsible officer on deck. This system is also to include the personnel in charge of ballast pump handling if boats and rafts are used.

3.2.11.3 Surveys of tanks or applicable holds by means of boats or rafts may only be undertaken at the sole discretion of the Surveyor, who is to take into account the safety arrangements provided, including weather forecasting and ship response under foreseeable conditions and provided the expected rise of water within the tank does not exceed 0.25 m.

3.2.11.4 When rafts or boats are used for close-up surveys, the following conditions are to be observed:

- .1 only rough duty, inflatable rafts or boats, having satisfactory residual buoyancy and stability even if one chamber is ruptured, should be used;
- .2 the boat or raft should be tethered to the access ladder and an additional person should be stationed down the access ladder with a clear view of the boat or raft;
- .3 appropriate lifejackets should be available for all participants;
- .4 the surface of water in the tank should be calm (under all foreseeable conditions the expected rise of water within the tank should not exceed 0.25 m) and the water level stationary. On no account should the level of the water be rising while the boat or raft is in use;
- .5 the tank or space must contain clean ballast water only. Even a thin sheen of oil on the water is not acceptable;
- .6 at no time should the water level be allowed to be within 1 m of the deepest under deck web face flat so that the survey team is not isolated from a direct escape route to the tank hatch. Filling to levels above the deck transverses should only be contemplated if a deck access manhole is fitted and open in the bay being examined, so that an escape route for the survey party

is available at all times. Other effective means of escape to the deck may be considered;

- .7 if the tanks (or spaces) are connected by a common venting system, or inert gas system, the tank in which the boat or raft should be used should be isolated to prevent a transfer of gas from other tanks (or spaces).

3.2.11.5 Rafts or boats alone may be allowed for inspection of the underdeck areas for tanks or spaces if the depth of the webs is 1.5 m or less.

3.2.11.6 If the depth of the webs is more than 1.5 m, rafts or boats alone may be allowed only:

- a) when the coating of the underdeck structure is in GOOD condition and there is no evidence of wastage; or
- b) if a permanent means of access is provided in each bay to allow safe entry and exit. This means:
 - access direct from the deck via a vertical ladder and a small platform fitted approximately 2 m below the deck in each bay; or
 - access to deck from a longitudinal permanent platform having ladders to deck in each end of the tank. The platform shall, for the full length of the tank, be arranged in level with, or above, the maximum water level needed for rafting of under deck structure. For this purpose, the ullage corresponding to the maximum water level is to be assumed not more than 3m from the deck plate measured at the midspan of deck transverses and in the middle length of the tank (see Figure 3.2.11.6-1).

NOTE: Unified interpretations of SOLAS Chapters II-1 and XII, of the technical provisions for means of access for inspection (MSC.158(78)), are given in the MSC.1/Circ.1572/Rev.2.

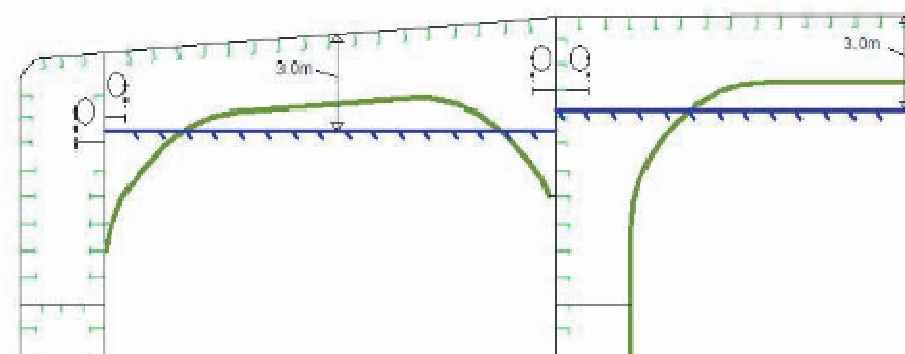

Figure 3.2.11.6-1

If neither of the above conditions are met, then staging or another equivalent means is to be provided for the survey of the underdeck areas.

The use of rafts or boats alone does not preclude the use of boats or rafts to move about within a tank during a survey.

3.2.11.7 On ships 20.000 tonnes DWT and above, subject to ESP, starting with Renewal survey No. 3 (commenced on or after 1 July 2001) at Renewal and Intermediate surveys, the survey of hull structure and piping systems is to be carried out by at least two exclusive Surveyors. On “Capesize” bulk carriers of single side skin construction the intermediate hull classification survey between 10 and 15 years of age, the survey of hull structure and piping systems is to be performed by at least two exclusive Surveyors (definition of a “Capesize” bulk carriers is 100.000 DWT and over). This requires that at least two exclusive Surveyors attend on board to jointly perform the required survey and to co-sign the survey report.

NOTE: It is confirmed that this also applies to voyage surveys.

On dual class vessels, the requirement for two Surveyors may be fulfilled by having one Surveyor attend from each society.

Though each attending Surveyor is not required to perform all aspects of the required survey, they are required to consult with each other and to do joint overall and close-up surveys to the extent necessary to determine the condition of the vessel areas. The extent of these surveys should be sufficient for the surveyors to agree on actions required to complete the survey with respect to renewals, repairs, and other conditions of class. Each surveyor is required to co-sign the survey report or indicate their concurrence in an equivalent manner.

The following surveys may be witnessed by a single Surveyor:

- a) Thickness measurements.
- b) Tank testing.
- c) Repairs carried out in association with Intermediate and Renewal Hull Classification Survey, the extent of which have been agreed upon by the required two surveyors during the course of the surveys.

3.2.11.8 When the attending Surveyor realises that, for whatever reason, the survey requested cannot take place or cannot continue to the completion, the Head office is to be contacted for further communication with Company’s representative.

3.3 DOCUMENTATION

3.3.1 For ships built after 1st January 2007, with IMO number assigned, engaged in international voyages (ships having navigation area **1** to **4**), the Company is to supply and maintain on board as-built construction drawings as listed below:

- .1 General arrangement,
- .2 Capacity plan,
- .3 Hydrostatic curves,
- .4 Loading manual, where required,
- .5 Midship section with scantling plan,
- .6 Decks,

- .7 Shell expansion,
- .8 Transverse bulkheads,
- .9 Rudder and rudder stock,
- .10 Cargo hatch covers, when applicable,
- .11 Bilge, ballast and cargo piping diagrams.

For all ships Company is to supply and maintain on board a Survey report file consisting of survey reports and thickness measurement reports (as applicable) for reference at future surveys.

3.3.2 For tankers and bulk carriers on which Enhanced Survey Programme is applied, the Company is to supply on board the following documentation:

- .1 A Survey report file, which is to be a part of documentation on board consisting of:
 - a) reports of structural surveys,
 - b) Executive Hull Summary,
 - c) thickness measurement reports,

An Executive Hull Summary of the survey and results is to be issued to the Owner and placed on board the vessel for reference at future surveys. The Executive Hull Summary is to be endorsed by the *Register’s* Head Office.

- .2 Supporting documents, i.e. additional documentation consisting of:
 - a) Survey Programme (see 3.1) until such time as the Renewal survey or Intermediate Survey, as applicable, has been completed,
 - b) main structural plans of cargo holds, cargo and ballast tanks,
 - c) previous repair history,
 - d) cargo and ballast history,
 - e) inspections by ship’s personnel with reference to:
 - structural deterioration in general,
 - leakage in bulkheads and piping,
 - condition of corrosion prevention system, if any,
 - f) extent of use of inert gas plant and tank cleaning procedures,
 - g) any other information that will help to identify suspect areas requiring inspection.

3.3.3 Prior to inspection, the Surveyor is to examine the completeness of the documentation on board and its contents as a basis for the survey.

3.3.4 The Company is to keep above mentioned documentation for the lifetime of the ship.

3.4 REQUIREMENTS FOR SAFE ENTRY TO CONFINED SPACES

3.4.1 All Surveyors have personal responsibility of safeguarding themselves and shall not enter spaces where the use of respiratory protection is required to do routine inspection.

3.4.2 All spaces covered by this policy shall, after initial testing, be re-tested at intervals not exceeding eight hours.

3.4.3 The Surveyor shall enter the above spaces only if accompanied by a person having responsibility for the work and watch is being maintained at the entry to the space, and

the watch officer, or person-in-charge is to assure continuous communication with the Surveyor. Any welding, cutting, grinding, flatterring and similar activity which may induce heat to the insulation is forbidden in the insulated spaces and adjacent insulated spaces, prior or during the entry for inspection of the space.

3.4.4 All spaces should be continuously forced ventilated during entry and immediately prior to entry for a sufficient period of time to produce a minimum of three air changes.

3.4.5 All cargo pipelines leading to or passing through space should as far as practicable be drained and flushed with water. Valves in all pipelines leading to the space should be securely closed and signposted.

3.4.6 The following spaces on board a ship or barge or other marine vessel shall not be entered unless they have been certified as “safe for workers” by a marine chemist, or by an industrial hygienist:

- .1 Cargo spaces or other spaces containing or having contained bulk liquids, gases or solids of toxic, corrosive or irritant nature.
- .2 Spaces immediately adjacent to before mentioned spaces.
- .3 Compartments that have been sealed.
- .4 Spaces that have been coated and closed.
- .5 Freshly painted and unventilated compartments.
- .6 Spaces containing cargoes that absorb oxygen (e.g. scrap iron, fruit, molasses, vegetable oils, etc.)
- .7 Double bottoms.
- .8 Spaces immediately adjacent to hot work spaces.

3.4.7 Spaces stated in 3.4.6.3 to 3.4.6.8 may be certified as “safe for workers” by other persons than those stated before (i.e. marine chemist or industrial hygienist). The Company in this case may authorise another person who has been trained in the hazards of confined spaces and is knowledgeable about the equipment and procedures for ascertaining that a confined space is safe for entry.

3.4.8 Detailed requirements for safe entry to confined spaces are stated in the guidelines of the *Register* and are to be in accordance with IACS PR37.

4 ANNUAL SURVEY

4.1 GENERAL

4.1.1 Annual classification surveys are to be held concurrently with statutory Annual surveys or other relevant statutory surveys, wherever practicable.

For Annual survey requirements of IMO Res. **A.1186(33)** “Survey Guidelines Under the Harmonized System of Survey and Certification, (HSSC) **2023**”, which are, as a minimum, to be covered by classification surveys, refer to IACS UR Z1.

NOTE: Reporting on existence of asbestos on board

When classification surveys are performed concurrently with statutory surveys, under IACS PR 41 it is ensured that the Organisation responsible for the issue of the Passenger Ship Safety Certification (PSSC), Cargo Ship Safety Construction (SAFCON) Certification or Cargo Ship Safety Certification (CSSC) of the ship and the flag Administration, as appropriate, are notified when the existence of asbestos on board is identified by another Class Society who carries out a survey or audit onboard, for example IHM, ISM or MLC.

4.1.2 At Annual classification surveys the Surveyor is to examine the hull, hull equipment, machinery and electrical devices, and the fire protection arrangements, so far as necessary and practicable in order to be satisfied as to their general condition. The survey of hull is to consist of an examination for the purpose of ensuring, as far as practicable, that the hull, hatch covers, hatch coamings, closing appliances, equipment and related piping are maintained in a satisfactory condition. The Surveyor is also to report evidence of possible safety management failures recorded during Annual classification surveys.

From 1st January 2011, for all ships, new installation of materials which contain asbestos is prohibited. In the context of this regulation, new installation of materials containing asbestos means any new physical installation on board. Any such material purchased prior to 1st January 2011 being kept in the ship’s store, is not permitted to be installed on board. For additional reference see the *Rules for the classification of ships, Part 1 – General requirements, Chapter 2 – Survey during construction and initial survey, 1.1.*

For additional Annual survey requirements for fuel installations on ships other than liquified gas carriers utilizing gas or other low-flash point fuel refer to Annex E of this Chapter of the Rules.

4.2 HULL AND HULL EQUIPMENT SURVEY - STEEL SHIPS, ALUMINIUM ALLOY SHIPS - ALL SHIPS

4.2.1 General requirements

4.2.1.1 The Surveyor is to confirm that the stability and where applicable loading and ballasting information are on board. Electronic loading instrument where required is to be checked according to test examples as stated in operation manual.

4.2.1.2 The Surveyor is to check that no alternations have been made to the hull or superstructures that would affect the position of the load line.

4.2.1.3 The Surveyor is to be satisfied as to the efficient condition of the following:

- .1 All openings on the ship’s side below the freeboard deck and their closing appliances including bow, side and stern doors.
- .2 Weather deck plating, superstructure end bulkheads, deck houses and the openings therein together with all closing appliances.
- .3 Hatchways on freeboard and superstructure decks, exposed casings and skylights together with closing appliances.
- .4 Ventilator coamings and air pipes including closing appliances and flame screens.
- .5 Vent ducts, exits from machinery and boiler spaces including closing appliances and flame screens.
- .6 Side scuttles, deadlights, and windows with their means of closure.
- .7 Scuppers and sanitary discharges, valves on discharge lines and their controls and inlets (so far as it is practicable).
- .8 Bulwarks, freeing ports, and shutters arrangement if applicable.
- .9 Guardrails, gangways, walkways, and other means provided for the protection of the crew’s quarters working spaces.
- .10 Fittings and appliances for timber deck cargoes.
- .11 Freeboard marks.

4.2.1.4 Anchoring and mooring equipment is to be examined.

Additionally, while applying the requirements of SOLAS regulation II-1/3-8.9, the following shall be complied with, and compliance shall be confirmed by the surveyor at the initial survey for new ships or at the first annual / intermediate / renewal survey for the issuance of the Cargo Ship Safety Construction Certificate or renewal survey for the issuance of the Passenger Ship Safety Certificate and corresponding class survey after 1 January 2024 for existing ships:

- .1 procedures for mooring operations, inspection and maintenance of mooring equipment, including mooring lines, shall be established and available on board (paragraph 3.1 of MSC.1/Circ.1620), taking into account industry practices (section 7 of MSC.1/Circ.1620);
- .2 procedures to allow the identification and control of mooring lines, tails and associated attachments shall be established and available on board (paragraph 3.3 of MSC.1/Circ.1620);
- .3 the periodic inspection of mooring lines, mooring line tails and associated attachments shall be included in the onboard maintenance plan or equivalent maintenance management system (paragraph 4.1.1 of MSC.1/Circ.1620);

- .4 manufacturers' criteria for replacement of mooring lines shall be available (paragraph 4.3.1 of MSC.1/Circ.1620);
- .5 records of the original design concept, equipment, arrangements and specifications shall be available on board (paragraph 4.4.4 of MSC.1/Circ.1620). For ships the keels of which were laid before 1 January 2007 and without appropriate documentation, owners may establish the MBLSD for mooring based on the safe working load of mooring equipment provided on board. If no safe working load is specified, then owners are advised to check strength of mooring equipment and their supporting hull structure based on MSC.1/Circ.1175/Rev.1 and determine MBLSD based on actual capacity of the equipment and their supporting hull structure on board. Manufacturers' test certificates for mooring lines, joining shackles and synthetic tails shall be kept on board and properly linked back to the equipment, if available (paragraph 6.2 of MSC.1/Circ.1620); and
- .6 a document shall be provided on board for gathering the information above and describing how the information listed above is filed and collected.

Additionally, while applying the requirements of SOLAS regulation II-1/3-8.9, the following shall be complied with, and the compliance shall be confirmed by the surveyor at every periodical survey for endorsement/issue of the Cargo Ship Safety Construction Certificate or every renewal survey for the Passenger Ship Safety Certificate and corresponding class survey after 1 January 2024 for existing ships:

- .1 the records of inspection and maintenance of mooring equipment and inspection and replacement of mooring lines, since the last periodical survey, shall be kept updated and available on board (paragraphs 4.4.3 and 6.1 of MSC.1/Circ.1620).

4.2.1.5 The collision and other watertight bulkheads including watertight bulkhead penetrations are to be examined together with an examination and testing (locally and remotely) of the watertight doors in watertight bulkheads, as far as accessible and practicable.

4.2.1.6 Main and auxiliary steering arrangements are to be examined and tested in operation, including their associated equipment and control systems, together with alarms and re-charging arrangements for hydraulic power operated steering gears.

4.2.1.7 In addition to above mentioned the following is to be carried out:

- .1 Suspect areas identified at previous surveys are to be examined.
- .2 **Thickness measurements are to be taken of the areas of substantial corrosion (identified at previous surveys)** and the extent of thickness measurements is to be increased to determine areas of substantial corrosion. Table 7.2.1-3a may be used as

guidance for these additional thickness measurements. These extended thickness measurements are to be carried out before the annual survey is credited as completed.

NOTE: These requirements are not applicable to cargo tanks of oil tankers, chemical tankers and double hull oil tankers

- .3 Examination of ballast tanks when required as a consequence of the results of the Renewal Survey and Intermediate Survey is to be carried out. When considered necessary by the Surveyor, or where extensive corrosion exists, thickness measurement is to be carried out. If the results of these thickness measurements indicate that Substantial Corrosion is found, then the extent of thickness measurements is to be increased to determine areas of substantial corrosion. Table 7.2.1-3a may be used as guidance for these additional measurements. These extended thickness measurements are to be carried out before the annual survey is credited as completed.

4.2.2 Examination of weather decks, ship side plating above water line, hatch covers and coamings

4.2.2.1 Confirmation is to be obtained that no unapproved changes have been made to the hatch covers, hatch coamings and their securing and sealing devices since the last survey.

4.2.2.2 Where mechanically operated steel covers are fitted, checking the satisfactory condition of:

- .1 Hatch covers, including close-up survey of hatch covers.
- .2 Tightness devices of longitudinal, transverse, and intermediate cross junctions (gaskets, gasket lips, compression bars, drainage channels).
- .3 Clamping devices, retaining bars, cleating, chain, or rope pulleys.
- .4 Guides, guide rails and track wheels.
- .5 Stoppers, etc.,
- .6 Wires, chains, gypsies, tensioning devices.
- .7 Hydraulic system essential to closing and securing, safety locks and retaining devices.

4.2.2.3 Where portable covers, wooden or steel pontoons are fitted, checking the satisfactory condition where applicable of:

- .1 Wooden covers and portable beams, carriers or sockets for the portable beam, and their securing devices, steel pontoons, tarpaulins.
- .2 Cleats, battens, and wedges.
- .3 Hatch securing bars and their securing devices, loading pads/bars and the side plate edge.
- .4 Guide plates and chocks, compression bars, drainage channels, and drain pipes (if any).

4.2.2.4 Checking the satisfactory condition of hatch coaming plating and their stiffeners, where applicable.

4.2.2.5 Random checking of the satisfactory operation of mechanically operated hatch covers is to be performed including:

- .1 Stowage and securing in open condition.
- .2 Proper fit, locking and efficiency of sealing in closed condition.
- .3 Operational testing of hydraulic and power components, wires, chains and link drives.

4.2.2.6 The watertightness of hatch covers shall be checked by hose testing or another suitable means (chalk marking, testing with ultrasonic equipment) if considered necessary by the Surveyor.

4.2.2.7 Following is to be carried out:

- .1 Examination of the weld connection between air pipes and deck plating.
- .2 External examination of all air pipe heads installed on the exposed decks.
- .3 Examination of flame screens on vents to all bunker tanks.
- .4 Examination of ventilators, including closing devices, if any.

4.2.3 Bow doors, inner doors, side shell doors and stern doors on Ro-Ro passenger ships

Requirements for surveys of bow doors, inner doors, side shell doors and stern doors on Ro-Ro passenger ships are stated in 4.14.1.1.

4.2.4 Additional requirements regarding hull repairs - all self-propelled ships

4.2.4.1 Any damage in association with wastage over the allowable limits (including buckling, grooving, detachment or fracture), or extensive areas of wastage over the allowable limits, which affects or, in the opinion of the Surveyor will affect the ship's structural, watertight or weathertight integrity, is to be **promptly and thoroughly** (see 1.2.17) repaired. Areas to be considered include:

- side shell frames or structure (for oil tankers), their end attachments and adjacent shell plating;
- deck structure and deck plating;
- bottom structure and bottom plating;
- watertight or oiltight bulkheads;
- hatch covers and hatch coamings;
- weld connection between air pipes and deck plating, all air pipe heads installed on the exposed decks as well as ventilators, including closing devices, if any.

For bulk carriers only, following additional areas to be considered:

- inner bottom structure and inner bottom plating;
- inner side structure and inner side plating.

4.2.4.2 For locations where adequate repair facilities are not available, consideration may be given to allow the ship to proceed directly to a repair facility. This may require discharg-

ing the cargo and/or temporary repairs for the intended voyage.

4.2.4.3 Additionally when a survey results in the identification of structural defect or corrosion, either of which in the opinion of the Surveyor will impair the ship's fitness for continued service, remedial measures are to be implemented before the ship continues in service.

4.2.4.4 Where the damage found on structure mentioned in 4.2.4.1 is isolated and of a localised nature which does not affect the ship's structural integrity, consideration may be given by the surveyor to allow an appropriate temporary repair to restore watertight or weather tight integrity and impose a Condition of Class with a specific time limit.

4.2.5 Surveys of Watertight Cable Transits

4.2.5.1 These requirements apply to all vessels having $GT \geq 500$ operating on international voyages contracted for construction on or after 1st July 2021. A Cable Transit Seal Systems Register is to be provided by the shipbuilder for all watertight cable transits fitted to the vessel.

4.2.5.2 The Cable Transit Seal Systems Register is to be reviewed to confirm it is being maintained and as far as practicable the transits are to be examined to confirm their satisfactory condition.

4.2.5.3 Where there are records entered since the last annual survey of any disruption to the cable transits or installation of new cable transits, the satisfactory condition of those transits is to be confirmed by review of records and, if deemed necessary, by examination. The results are to be recorded in the Cable Transit Seal Systems Register against the specific cable transit.

4.3 HULL AND HULL EQUIPMENT SURVEY - WOODEN SHIPS, AND FIBER REINFORCED PLASTIC SHIPS - ALL SHIPS

4.3.1 Annual survey is to be carried out in order to verify that the hull and its equipment are in satisfactory and efficient condition, and that no unapproved alternations have been made. The following are to be dealt with so far as is practicable:

- .1 Freeboard marks are to be checked.
- .2 The outside shell above the waterline is to be examined, with particular attention to the butts of sheerstrake and shell planking.
- .3 Weather decks are to be examined with particular attention to the butts of waterways, inner waterways, and planking.
- .4 Hatchways and cargo hatch covers including closing and securing appliances (see also 4.2.2, if applicable) as well as other deck openings with closing appliances.
- .5 Guard rails, bulwarks, freeing ports, mooring equipment, and other deck fittings are to be examined.
- .6 Masts and rigging (steady and loose gear) including lightning conductors are to be examined.

- .7 Towline, hawsers and warps, and stream anchor, wire rope (or chain) if required is to be examined.
- .8 The windlass is to be examined externally and in working condition.
- .9 It is to be verified that the equipment of anchors and chain cables is complete, and chain cables are to be examined as far as accessible.
- .10 Main and auxiliary steering arrangements are to be checked, with particular attention to the rod and chain gear if fitted.
- .11 The deck outfit, tools and gear are to be verified.
- .12 Enclosed spaces, as far as accessible at the time of the survey are to be examined.
- .13 Portions of the inner planking and ceiling are to be removed for detailed examination and testing of timbers by axe, chisel or other suitable tool if considered necessary by the Surveyor.
- .14 For fiber-reinforced plastic ships survey of the connection between hull and superstructure is to be carried out, particularly when hull and superstructure are not built from the same material. Additionally, the hull survey is to be performed by sound pattern hammer testing.

4.4 MACHINERY, ELECTRICAL EQUIPMENT AND FIRE PROTECTION - ALL SHIPS

4.4.1 Machinery and electrical equipment

4.4.1.1 General examination of machinery and boiler spaces is to be carried out with particular regard to the main propulsion system, auxiliary machinery arrangements and piping systems used for essential services on board (in particular insulation and gauges), main shafting, main and auxiliary boilers and pressure vessels with their fittings, safety and control devices and piping systems. Particular attention is to be given to the existence of any danger to persons on board due to moving parts, hot surfaces as well as fire and explosion hazards.

4.4.1.2 It is to be confirmed that the engine room telegraph, the second means of communication between the navigation bridge and the machinery space and the means of communication with any other positions from which the engines are controlled are operated satisfactorily. Also, it is to be confirmed that the means of communication between the navigation bridge and steering gear (or alternative steering position if fitted) are operating satisfactorily.

4.4.1.3 The bilge pumping systems and bilge wells, including operation of extended spindles and level alarms, where fitted, are to be examined so far as practicable. All bilge pumps are to be tested under operating conditions.

4.4.1.4 The means for the operation of the main and auxiliary machinery essential for propulsion and the safety of the ship are to be examined including, when applicable, the means of remotely controlling the propulsion machinery from

the navigating bridge and the arrangements to operate the main and other machinery from a machinery control room.

4.4.1.5 Electrical equipment and installations including main and emergency sources of power, switchboards, switchgears, cables and circuit protective devices and earth bonding straps are to be examined under operating conditions so far as is applicable. Automatic starting of emergency sources of power, where provided, is to be checked.

4.4.1.6 It is to be examined that the precautions against shock, fire and other hazards of electrical origin are being maintained.

External examination of pressure vessels other than boilers and their appurtenances, including safety devices, foundations, controls, relieving gear, high pressure piping, insulation and gauges is to be carried out.

4.4.1.7 For periodically unattended machinery spaces a general examination of automation equipment is to be carried out, and operation of safety devices and control systems is to be checked. Also, it is to be confirmed that the engineer's alarm is clearly audible in the engineer's accommodation.

For ships built after 1st July 2002 with class notation **AUT 1**, at annual classification surveys Surveyor is to examine and verify approved "Maintenance and testing program for automation system".

The plan for systematic maintenance and function testing is to show in detail how components and systems affecting main functions. Columns showing test dates and verification of tests carried out are to be included.

The longest intervals for functional alarms testing are not to surpass 12 months and for critical alarms not to exceed 6-month intervals.

4.4.1.8 It is to be confirmed that the normal operation of the propulsion machinery can be sustained or restored even though one of the essential auxiliaries become inoperative, and, that means are provided, so that the machinery can be brought into operation from the dead ship condition without external aid.

4.4.1.9 Emergency escape routes from machinery and boiler spaces as well as from accommodation and other spaces are to be checked to ensure that they are free of obstruction.

4.4.2 Fire protection

NOTE: Survey of fire protection systems and appliances shall be carried out taking into account applicable Flag Administration requirements, such as MSC.1/Circ.1432 (Revised Guidelines for the maintenance and inspection of fire protection systems and appliances), as amended by MSC.1/Circ.1516.

4.4.2.1 It is to be checked that following Plans and Manuals for fire protection systems and firefighting systems and appliances are available on board:

- Maintenance plan.
- Training manual.
- Fire safety operational booklet.

It is to be confirmed that the fire plans are permanently exhibited or, alternatively, emergency booklets have been provided and that a duplicate of the plans or the emergency booklet are available in a prominently marked enclosure external to the ship's deckhouse. Also checking that records of

the inspections and maintenance are kept onboard is to be done.

4.4.2.2 It is to be confirmed as far as practicable that no changes have been made in the structural fire protection. Also, verification of the operation of manual and/or automatic fire doors where fitted, and testing of the means of closing the main inlets and outlets of all ventilation systems from outside the space served is to be carried out.

4.4.2.3 Any fire detection and alarm system is to be examined as far as possible and tested as feasible (particularly in machinery and cargo spaces).

4.4.2.4 The fire pumps, fire main, hydrants, hoses and nozzles, and the international shore connection are to be examined and tested for operation (at least 20% of the available fire hoses and nozzles are to be included in the testing of the fire main system). It is to be checked that each fire pump, including the emergency fire pump can be operated separately, so that two jets of water are produced simultaneously from different hydrants at any part of the ship whilst the required pressure is maintained in the fire main. Also, where fitted, sprinkler system connections from the ship's fire main, are to be tested for operation.

4.4.2.5 All portable and semi-portable fire extinguishers are to be checked for proper location, charging pressure and condition, and evidence of discharged containers. Service intervals are also to be checked (servicing is to be carried out at intervals not exceeding 12 months by an approved service station).

NOTE: Annual inspection/maintenance is to be carried out by competent person/ship's responsible safety officer, in accordance with manufacturer's instructions.

It is to be confirmed that the firemen's outfits and emergency escape breathing devices – EEBD's are complete and in good condition, and that the cylinders, including the spare cylinders, of any required self-contained breathing apparatus are suitably charged.

NOTE: It is recommended that intervals for hydraulic pressure testing of breathing apparatus air cylinders do not exceed 5 years. Any additional requirements from the Flag State will prevail.

4.4.2.6 The fixed fire protection arrangements in machinery spaces including fixed local application fire extinguishing system and cargo spaces (if fitted) are to be examined. It is also to be confirmed that fire main valves are distinguishably marked and that places from which fire system is controlled are supplied with instructions for use. Air should be blown through the piping of extinguishing gas systems.

CO₂ and Halon bottles of fixed firefighting systems are subject to crew's monthly and annual inspections in accordance with manufacturer's instructions and safety precautions. The records of fixed fire extinguishing system inspections kept onboard according to maintenance and inspection plan are to be examined.

4.4.2.7 The fire protection arrangements in cargo spaces are to be examined and the operation of the means of control provided for closing the various openings is to be confirmed so far as is practicable and as appropriate.

4.4.2.8 The operation of the remote means of control provided for the opening and closing of the skylights, the release of smoke, the closure of the funnel and ventilation open-

ings, and the closure of power operated and other doors, is to be examined.

4.4.2.9 It is to be examined so far as practicable the remote control for stopping of ventilation and boiler forced and induced draft fans, and the stopping of oil fuel and other pumps that can discharge flammable liquids.

4.4.2.10 The arrangements for oil fuel, lubrication oil and other flammable oils are to be examined, including so far as practicable and as appropriate the operation of the remote means of closing the valves on the tanks that contain oil fuel, lubrication oil and other flammable oils.

4.4.2.11 Fixed fire extinguishing systems are subject to maintenance by approved service firms every two years.

4.4.2.12 Where fixed foam fire extinguishing system is used, report on foam concentrates from foam manufacturer or independent laboratory is to be checked (foam concentrates should be subjected to periodical control after the period of three years after filling into the system, and after that every year). The arrangement of periodical control should follow IMO MSC.1/Circ.1312 (including IMO MSC.1/Circ.1312/Corr.1) as amended.

4.4.2.13 The arrangements for storage, distribution, and usage of gaseous fuel for domestic purposes are to be examined.

Examining the fire extinguishing arrangements for spaces containing paint.

Examining precautions against fire hazards in accommodation and domestic spaces including examination of exhaust ducts from galley ranges and deep fat cooking equipment. Testing the work of thermostat alarm and checking, where fitted, work of automatic fire-extinguishing system of deep-fat cooking equipment installed on ships after 1st July 2002.

4.4.3 Survey of towing winch emergency release systems subject to IACS UR M79 (Towing winch emergency release systems)

4.4.3.1 Operation of the towing winch emergency release system is to be confirmed with the reference to the documented instructions for surveys provided by the manufacturer. Operation of the winch emergency release system under no load condition is to be verified. Where practical, activation of the emergency release system may be confirmed by observation of the winch brake.

4.4.3.2 The function of the alarms associated with the emergency release system is to be verified, as far as practicable and reasonable.

4.4.3.3 The condition of the emergency release system is to be visually examined to confirm it remains in satisfactory condition.

4.4.3.4 The means of emergency release of the towline in the event of a blackout is to be examined, and where additional sources of energy are arranged for this purpose, the sources of energy are to be visually inspected and operationally tested.

4.4.3.5 It is to be verified that the performance capabilities and operating instructions of the emergency release system are documented and made available on board the ship on which the winch has been installed.

4.5 ADDITIONAL ANNUAL SURVEY REQUIREMENTS FOR OIL TANKERS WITH AFFIXED ESP NOTATION OTHER THAN DOUBLE HULL OIL TANKERS

4.5.1 Examinations according to the requirements stated in 4.2 and 4.4 are to be carried out as appropriate.

The survey is to consist of an examination for the purpose of ensuring, as far as practicable, that the hull and piping are maintained in a satisfactory condition and should take into account the service history, condition and extent of the corrosion prevention system of ballast tanks and areas identified in the survey report file.

4.5.2 It is to be confirmed, where appropriate, that the requisite arrangements to regain steering capability in the event of single failure in its piping system or in one of the power units are being maintained.

4.5.3 Cargo tank openings are to be examined including gaskets, covers coamings and screens.

4.5.4 Cargo pressure/vacuum valves and devices to prevent the passage of flame are to be examined so far as practicable.

4.5.5 Flame screens on vents to all bunker tanks, and void spaces are to be examined so far as is practicable.

4.5.6 Cargo tank venting, cargo tank purging and gas freeing systems are to be examined including flame arrestors and pressure/vacuum valves as applicable above the upper deck within the cargo tank area, also including vent masts and headers.

4.5.7 Cargo, crude oil washing, ballast and stripping systems, both on deck and in the cargo pump rooms and the bunker system on deck are to be examined.

4.5.8 It is to be confirmed that no potential sources of ignition such as loose gear, combustible materials, excessive products in the bilges, etc. are present in or near the cargo pump room, and that access ladders are in good condition.

4.5.9 All pump room bulkheads are to be examined for signs of oil leakage or fractures and, in particular, the sealing arrangements of all penetrations in cargo pump room bulkheads are to be checked.

4.5.10 It is to be confirmed that the pump room ventilation system is operational, ducting intact, dampers operational and screens are clean.

4.5.11 It is to be confirmed that all electrical equipment in dangerous zones is suitable for such locations, is in good condition and is being properly maintained.

4.5.12 Cargo, bilge, ballast and stripping pumps are to be examined so far as is practicable for undue gland seal leakage.

Proper operation of electrical and mechanical remote operating and shutdown devices, and operation of cargo pump room bilge system, is to be confirmed, and it is to be checked that pump foundations are intact.

4.5.13 It is to be confirmed that installed pressure gauges on cargo discharge lines and level indicator systems are operational.

4.5.14 The emergency towing arrangements (on tankers for oil and chemical tankers with DWT \geq 20,000) is to be examined to ensure ready availability.

4.5.15 It is to be confirmed that:

- .1 Secondary means of allowing full flow relief of vapours, air or inert gas to prevent over/under pressure of tanks in the event of failure of the primary gas pressure/vacuum relief system is provided, or alternatively, pressure sensors are fitted in the tank, monitored in the cargo control room, and provided with an alarm activated in the event of over/under pressure.
- .2 Any stop valves or other means provided to isolate cargo tanks have clear indication of their operational status and where tanks have been isolated means are provided to ensure the valves are opened before any cargo or ballasting operations commence.
- .3 If cargo or ballasting operations are intended for a tank or group of tanks which are isolated from the common venting system, such tanks have means of preventing over or under pressure.

4.5.16 Piping and cut-out valves of cargo tank and cargo pump room fixed fire-fighting system are to be examined.

4.5.17 In addition to the requirements stated in 4.4.2, the deck foam system, including the supplies of foam concentrate and testing that the minimum number of jets of water at the required pressure in the fire main is obtained, are to be checked, when the system is in operation. Fire-fighting arrangements in the pump room are to be checked.

4.5.18 Condition of all piping systems in the cargo pump room is to be examined so far as practicable.

4.5.19 It is to be confirmed, so far as practicable, that the crude oil washing system remains satisfactory and in particular:

- .1 The crude oil washing piping, pumps, valves and deck mounted washing machines are to be examined externally for signs of leakage and is to be checked that all anchoring devices for crude oil washing piping are intact and secure.
- .2 In those cases where drive units are not integral with the tank cleaning machines it is to be confirmed that the number of operational drive units as specified in the Operations and Equipment Manual are on board.
- .3 It is to be checked that, when fitted, steam heaters for water washing can be properly isolated during crude oil washing operations, either by double shut-off valves or clearly identifiable blanks.

- .4 It is to be checked that the prescribed means of communication between the deck watchkeeper and the cargo control position is operational.
- .5 It is to be confirmed that an overpressure relief device (or other approved arrangement) is fitted to the pumps supplying the crude oil washing systems.
- .6 It is to be confirmed that flexible hoses for supply of oil to the washing machines on combination carriers, are of an approved type, are properly stored and are in good condition.
- .7 Tanks containing departure and/or arrival ballast water are to be checked, so far as is practicable, to confirm the effectiveness of the cleaning and stripping.
- .8 It is to be checked, as far as practicable, that the crude oil washing machines are operable, and, when the survey is carried out during crude oil washing operations, observing the proper operation of the washing machines by means of the movement indicators and/or sound patterns or other approved methods is to be carried out.
- .9 The effectiveness of the stripping system in appropriate cargo tanks is to be checked so far as practicable by observing the monitoring equipment and by hand-dipping or other approved means.

4.5.20 Examination of ballast tanks where required as a consequence of the results of the Renewal survey or Intermediate survey is to be carried out. When considered necessary by the Surveyor, or when extensive corrosion exists, thickness measurements are to be carried out. If the results of these thickness measurements indicate that Substantial corrosion is found, the extent of thickness measurements should be increased in accordance with Table 7.7.2-2. These extended thickness measurements are to be carried out before the survey is credited as completed. Suspect Areas identified at previous surveys are to be examined. **Areas of substantial corrosion identified at previous surveys are to have thickness measurements taken.**

4.6 ADDITIONAL ANNUAL SURVEY REQUIREMENTS FOR BULK CARRIERS WITH AFFIXED ESP NOTATION

4.6.1 For bulk carriers, examination of bunker and vent piping systems, including ventilators is to be carried out.

The requirements of Annex C1 are to be complied with as applicable.

4.7 ANNUAL SURVEY REQUIREMENTS FOR CHEMICAL TANKERS

4.7.1 Examinations according to the requirements stated in 4.2, 4.4 and 4.5 are to be fulfilled as far as applicable (for chemical tankers with affixed **ESP** notation see also Annex A).

4.7.2 Gauging devices, high level alarms and valves associated with overflow control are to be examined.

4.7.3 Cargo heating/cooling system sampling arrangements are to be examined where fitted, and satisfactory condition of any devices provided for measuring the temperature of the cargo, and any associated alarms is to be confirmed.

4.7.4 Wheelhouse doors and windows, side scuttles and windows in superstructure and deckhouse ends facing the cargo area are to be in good condition.

4.7.5 It is to be confirmed that pumps, valves and pipelines are identified and distinctively marked.

4.7.6 It is to be confirmed that the remote operation of the cargo pump room bilge system is satisfactory.

4.7.7 Cargo transfer arrangements are to be examined and it is to be confirmed that any hoses are suitable for their intended purpose.

4.7.8 It is to be confirmed that the condition of the portable fire extinguishing equipment for the cargoes to be carried in the cargo area is satisfactory.

4.7.9 It is to be confirmed that arrangements are made for sufficient gas to be carried or generated to compensate for normal losses and that the means provided for monitoring ullage spaces are satisfactory.

4.7.10 It is to be confirmed that arrangements are made for sufficient medium to be carried where drying agents are used on air inlets to cargo tanks.

4.7.11 It is to be confirmed, when applicable, that the bow or stern loading and unloading arrangements are in order, and testing of the means for communication and the remote shut down for the cargo pumps is to be carried out.

4.7.12 The equipment for personal protection is to be examined and in particular it is to be confirmed that:

- .1 The protective clothing for crew engaged in loading and discharging operations and its stowage is in satisfactory condition.
- .2 The required safety equipment and associated breathing apparatus and associated air supplies and, when appropriate, emergency escape respiratory and eye protection are in a satisfactory condition and are properly stowed.
- .3 Medical first aid equipment, including stretchers and oxygen resuscitation equipment are in satisfactory condition.
- .4 Arrangements have been made for the antidotes for the cargoes actually carried to be on board.

- .5 Decontamination arrangements and eye-washes are operational.
- .6 The required gas detection instruments are on board and that arrangements have been made for the supply of the appropriate vapour detection tubes.
- .7 The arrangements for the stowage of cargo samples are satisfactory.

4.7.13 It is to be confirmed that removable pipe lengths or other approved equipment necessary for cargo separation are available in the pump room and are in satisfactory condition.

4.7.14 It is confirmed that there are no signs of undue leakage in cargo pump room and that rescue arrangements (access ladders) are in satisfactory condition.

4.7.15 The arrangements for the ventilation of spaces normally entered during cargo handling operations and other spaces in the cargo area are to be examined so far as is practicable and confirmed their satisfactory operation.

4.7.16 It is to be confirmed, so far as is practicable, that the intrinsically safe systems and circuits used for measurement, monitoring, control and communication purposes in all hazardous locations are being properly maintained.

4.7.17 The tank washing piping is to be examined externally and it is to be confirmed that the type, capacity, number and arrangement of the tank washing machines are as approved.

4.7.18 The wash water heating system is to be examined externally.

4.7.19 The underwater discharge arrangements are to be examined externally so far as practicable.

4.7.20 It is to be confirmed that the means of controlling the rate of discharge of the residue is as approved.

4.7.21 It is to be confirmed that the flow rate indicating device is operable.

4.7.22 It is to be confirmed that the ventilation equipment for residue removal is as approved.

4.7.23 The heating system required for solidifying and high viscosity substances is to be externally examined so far as it is accessible.

4.7.24 It is to be confirmed that any cargo tank high level alarms are operable.

4.7.25 It is to be confirmed that information relating to the chemical and physical of the products to be carried has been provided, as well as a manual covering procedures for cargo transfer, tank cleaning, gas freeing, ballasting, etc.

4.8 ADDITIONAL ANNUAL SURVEY REQUIREMENTS FOR SHIPS WITH INERT GAS SYSTEM FITTED

4.8.1 It is to be externally examined the condition of piping and components including vent piping above the upper deck in the cargo tank area and overboard discharges through the shell so far as practicable, for signs of corrosion or gas/effluent leakage.

4.8.2 The proper operation of both inert gas blowers is to be confirmed.

4.8.3 The operation of the scrubber room ventilation system is to be checked.

4.8.4 The deck water seal is to be checked for automatic filling and draining, together with the operation of the non-return valve.

4.8.5 The operation of all remotely operated and automatically controlled valves and in particular, the flue gas isolating valves are to be examined.

4.8.6 The interlocking features of soot blowers are to be tested.

4.8.7 It is to be checked that the gas pressure regulating valve automatically closes when the inert gas blowers are secured.

4.8.8 The following alarms and safety devices of the inert gas system are to be checked so far as practicable and using simulated conditions where necessary:

- .1 High oxygen content of gas in the inert gas main.
- .2 Low gas pressure in the inert gas main.
- .3 High water level in the scrubber.
- .4 Failure of the inert gas blowers.
- .5 Failure of the power supply to the automatic control system for the gas regulating valve and to the instrumentation for continuous indication and permanent recording of pressure and oxygen content in the inert gas main.
- .6 Low pressure in the supply to the deck water seal.
- .7 High temperature of gas in the inert gas main.
- .8 High pressure of gas in the inert gas main.
- .9 Low water pressure or low water flow rate.
- .10 Accuracy of portable and fixed oxygen measuring equipment by means of calibration gas.

4.8.9 Examining the fixed fire-fighting system for the cargo pump rooms and confirming as far as practicable and when appropriate the operation of the remote means for closing the various openings.

Checking if there are available on board at least two portable instruments for measuring flammable vapour concentrations together with any necessary spares and means of calibration.

4.8.10 The proper operation of the inert gas system is to be checked, when practicable on completion of the checks listed above.

4.9 ANNUAL SURVEY REQUIREMENTS FOR FLOATING UNITS

4.9.1 During Annual survey of floating unit the following is to be confirmed, as far as can be seen and when appropriate:

- .1 That no unapproved alternations have been made to the hull or superstructures.
- .2 That the cargo is stowed and secured in accordance with the approved documentation.
- .3 That anchoring and mooring equipment as well as anchoring and mooring of floating unit is in accordance with the approved documentation.

4.9.2 For the hull and hull equipment the Annual survey consists of the provisions of 4.2 (or 4.3) as appropriate.

4.9.3 For the machinery and electrical installations as well as the fire protection arrangements the Annual survey consists of the provisions of 4.4 as appropriate.

4.9.4 When Annual survey of floating dock is to be carried out, then, in addition to aforementioned the equipment required for operation of the dock, e.g. bilge and keel blocks, their drives, bridge to deck and shore communications and shore connections are to be examined.

4.9.5 During Annual survey of floating unit it is also recommended survey on Continuous basis to be applied concurrently (see 2.3.1), except when another agreement is made between the Company and the *Register*. When survey on Continuous basis has been applied than in addition to Annual survey requirements, 10 to 20 % of items covered by the Renewal survey are to be examined.

4.10 ADDITIONAL ANNUAL SURVEY REQUIREMENTS AFTER DETERMINING COMPLIANCE WITH SOLAS 74, CH. II-I/25, FOR GENERAL CARGO SHIPS WITH SINGLE HOLD

4.10.1 For ships less than 80 meters in length, or for ships built before 1 July 1998 less than 100 meters in length, with single hold not protected by double hull, for hold, ballast and dry space water level detectors, the annual survey is to include an examination and a test, at random, of the water ingress detection systems and of their alarms.

4.11 ADDITIONAL ANNUAL SURVEY REQUIREMENTS FOR GENERAL DRY CARGO SHIPS

4.11.1 Examinations according to the requirements stated in 4.2 and 4.4 are to be fulfilled as far as applicable.

4.11.2 In addition to above mentioned the following is to be carried out:

- .1 Suspect Areas identified at previous Renewal Surveys are to be overall and close

up surveyed. Thickness measurements are to be taken of the area of substantial corrosion and the number of thickness measurements is to be increased to determine the extent of substantial corrosion. Table 7.2.1-3a may be used as guidance for these additional thickness measurements. These extended thickness measurements are to be carried out before the annual survey is credited as completed.

- .2 For ships 10-15 years of age:
 - a) Overall survey of one forward and one after cargo hold and their associated tween deck spaces.
 - b) When considered necessary by the Surveyor, or where extensive corrosion exists, thickness measurement is to be carried out. If the results of these thickness measurements indicate that Substantial corrosion is found, then the number of thickness measurements is to be increased to determine the extent of substantial corrosion. Table 7.2.1-3a may be used as guidance for these additional measurements. These extended thickness measurements are to be carried out before the annual survey is credited as completed.
- .3 For ships over 15 (fifteen) years of age:
 - a) Overall survey of all cargo holds and 'tween deck spaces.
 - b) Close-up examination of sufficient extent, minimum 25 % of frames, to establish the condition of the lower region of the shell frames including approximately lower one third length of side frame at side shell and side frame end attachment and the adjacent shell plating in a forward lower cargo hold and one other selected lower cargo hold. Where this level of survey reveals the need for remedial measures, the survey is to be extended to include a Close-up survey of all of the shell frames and adjacent shell plating of those cargo holds and associated 'tween deck spaces (as applicable) as well as a Close-up survey of sufficient extent of all remaining cargo holds and 'tween deck spaces (as applicable).
 - c) When considered necessary by the Surveyor, or where extensive corrosion exists, thickness measurement is to be carried out. If the results of these thickness measurements indicate that Substantial corrosion is found, then the number of thickness measurements is to be increased to determine the extent of substantial corrosion. Table 7.2.1-3a may be used as guidance for these additional measurements. These extended thickness measurements are to be carried out before the annual survey is credited as completed.

- d) Where the protective coating in cargo holds, as defined in 1.2.10 is found to be in GOOD condition, the extent of Close-up surveys and thickness measurements may be specially considered (see 1.2.13).
- e) All piping and penetrations in cargo holds, including overboard piping, are to be examined.
- 4 Examination of ballast tanks:
 - a) Examination of ballast tanks when required as a consequence of the results of the Renewal survey or Intermediate survey. When considered necessary by the Surveyor, or where extensive corrosion exists, thickness measurement is to be carried out. If the results of these thickness measurements indicate that Substantial corrosion is found, then the number of thickness measurements is to be increased to determine the extent of substantial corrosion. Table 7.2.1-3a may be used as guidance for these additional measurements. These extended thickness measurements are to be carried out before the annual survey is credited as completed.

4.12 ADDITIONAL ANNUAL SURVEY REQUIREMENTS FOR LIVE-STOCK CARRIERS

- 4.12.1** The survey is to include a general examination of:
- .1 spaces for the live-stock and related hatch covers (to be surveyed according to 4.2.2);
 - .2 ventilation means, including prime movers;
 - .3 main, emergency and portable lighting systems in live-stock spaces, passageways and access routes;
 - .4 the drainage system;
 - .5 fodder and fresh water systems;
 - .6 fire-fighting appliances, with working test as far as necessary and practicable (according to 4.4.2);
 - .7 means of escape, with confirmation they are kept clear.

4.13 ADDITIONAL ANNUAL SURVEY REQUIREMENTS FOR FAST VESSELS

4.13.1 High speed craft

Inspection of the structure, machinery safety equipment radio installations any stabilisation systems, air cushion systems and other equipment is to be carried out as far as applicable, to ensure that they are in satisfactory condition and are fit for the service for which the craft is intended and, that no unapproved changes have been made to structure, equipment, fittings, arrangements and materials covered by the survey.

The survey includes as far as applicable the following:

- .1 inspection of the outside of the craft bottom in accordance with the requirements stated in 6 with particular attention given to hull appendages (hydrofoils, hydrofoil supports, skirt fixations, shaft brackets, etc.) and to their fixation to the hull and, to the condition of the corrosion protection system of the structure,
- .2 inspection of the hull and machinery in accordance with 4.2 and 4.4.

4.13.2 Dynamically supported craft and Fast craft

Every year the survey in accordance with 4.13.1 is to be carried out as far as applicable.

4.14 ADDITIONAL ANNUAL SURVEY REQUIREMENTS FOR RO-RO CARGO SHIPS, PASSENGER SHIPS, RO-RO PASSENGER SHIPS

Following requirements apply to type notations **ro-ro cargo ship, passenger ship, ro-ro passenger ships**. Examinations according to the requirements stated in 4.2 and 4.4 are to be fulfilled as far as applicable.

4.14.1 Ro-Ro cargo ships

4.14.1.1 Shell and inner doors

- .1 The requirements of this item apply to all bow, inner, side shell and stern doors fitted on ships which utilize a loading ramp to enable wheeled vehicles to be rolled-on and rolled off of the ship.
- .2 For the scope of survey of shell and inner doors, the following definitions are applicable:
 - securing device: a device used to keep the door closed by preventing it from rotating about its hinges,
 - supporting device: a device used to transmit external or internal loads from the door to a securing device and from the securing device to the ship's structure, or a device other than a securing device, such as a hinge, stopper or other fixed device, that transmits loads from the door to the ship's structure,
 - locking device: a device that locks a securing device in the closed position.
- .3 It is to be verified that an approved copy of The Operating and Maintenance Manual (OMM) is on board and any possible modifications are included,
It is to be verified that the operating procedures for closing and securing doors are kept on board and posted at appropriate places,
The surveyor shall examine the OMM with special attention to the register of inspections and its contents as a basis for the survey.

- .4 Bow inner, side shell and stern doors are to be structurally examined with particular attention paid to:
- structural arrangement of doors including plating, secondary stiffeners, primary structure, hinging arms and welding,
 - shell structure surrounding the opening of the doors and the securing, supporting, and locking devices including shell plating, secondary stiffeners, primary structure, and welding,
 - hinges and bearings, thrust bearings,
 - hull and door side supports for securing, supporting, and locking devices.
- .5 A close-up survey of securing, supporting, and locking devices, including welding is to be carried out for:
- cylinder securing pins, supporting brackets, back-up brackets (where fitted) and their welded connections,
 - hinge pins, supporting brackets, back-up brackets (where fitted) and their welded connections,
 - locking hooks, securing pins, supporting brackets, back-up brackets (where fitted) and their welded connections,
 - locking pins, supporting brackets, back-up brackets (where fitted) and their welded connections,
 - locating and stopper devices and their welded connections.
- Whenever a crack is found, during structural examination or close-up survey, an examination with Non-destructive test is to be carried out in the surrounding area and for similar items as considered necessary by the surveyor.
- Clearances of hinges, bearings and thrust bearings are to be taken, where no dismantling is required. Where the function test is not satisfactory, dismantling may be required to measure the clearances. If dismantling is carried out, a visual examination of hinge pins and bearings together with NDT of the hinge pin is to be carried out. Clearances of securing, supporting and locking devices are to be measured, where indicated in the OMM.
- .6 An examination of sealing arrangements (packing material / rubber gaskets and retaining bars or channels including welding) is to be carried out.
- .7 The drainage arrangements including bilge wells, drain pipes, and non-return valves are to be examined. A test of the bilge system between the inner and outer doors is to be carried out.
- .8 Function tests of doors - checking of the satisfactory operation of the bow, inner, side shell and stern doors during a complete opening and closing operation is to be made, as applicable, including:
- proper working of hinging arms and hinges,
 - proper engagement of the thrust bearings,
 - proper working of devices for locking the door in open position are to be checked,
 - securing, supporting and locking devices,
 - proper sequence of the interlock system for the opening / closing system and the securing and locking devices,
 - mechanical lock of the securing devices,
 - proper locking of hydraulic securing devices in the event of a loss of the hydraulic fluid, according to the procedure provided by the OMM,
 - correct indication of open / closed position of doors and securing / locking devices at navigation bridge and other control stations,
 - isolation of the hydraulic securing / locking devices from other hydraulic systems,
 - confirmation that the operating panels are inaccessible to unauthorised persons,
 - verification that a notice plate giving instructions to the effect that all securing devices are to be closed and locked before leaving harbour is placed at each operating panel and supplemented by warning indicator lights,
 - examination of electrical equipment for opening, closing, and securing the doors.
- .9 Function test of the indicator system - checking of the satisfactory operation of the indicator system, where fitted, is to be carried out, as applicable, including:
- proper visible indication and audible alarm on the navigation bridge panel, according to the selected function "harbour / sea voyage" and on the operating panel,
 - lamp test function on both panels,
 - verification that it is not possible to turn off the indicator light on both panels,
 - verification of fail-safe performance, according to the procedure provided by the OMM,
 - confirmation that power supply for indicator system is supplied by the emergency source or other secure power supply and independent of the power supply for operating the doors,
 - proper condition of sensors and protection from water, ice formation and mechanical damage.
- .10 Test of water leakage detection system
Where fitted, the water leakage detection system is to be tested including proper au-

dible alarm on the navigation bridge panel and on the engine control room panel, according to the procedure provided by the OMM.

- .11 Test of television surveillance system
Where fitted, the television surveillance system is to be tested including proper indication on the navigation bridge monitor and on the engine control room monitor.
- .12 Tightness test
A hose test or equivalent is to be carried out. If the visual examination and function test have shown satisfactory results, the tightness test of shell doors on Ro-Ro cargo ships need not be carried out unless considered necessary by the attending surveyor.
- .13 NDT and Thickness Measurements
When considered necessary by the surveyor, NDT and thickness measurements may be required after visual examination and function test.

4.14.1.2 Internal platforms and ramps

- .1 The annual survey of internal movable platforms and ramps (excluding those considered as inner doors and covered in 4.14.1.1 and related equipment consists of:
 - a general examination of the installation, particular attention being paid to the condition of steel cables;
 - conformation of the proper operation of platforms/ramps and of mechanical stops and locks;
 - checking, as far as practicable, of the alarms and safety devices.

4.14.1.3 Fire protection, detection and extinction

- .1 Within the scope of survey of fire protection, detection and extinction arrangements as required for the annual survey of all ships in 4.4.2 attention is to be given to the particular arrangements related to Ro-Ro cargo spaces, such as:
 - fire detection systems, and alarms;
 - fixed fire-extinguishing arrangements (gas, water-spraying or foam systems);
 - portable fire extinguishers in spaces, and at entrances;
 - ventilation and related safety devices (including remote control on the bridge); and
 - electrical equipment of a safe type.

4.14.2 Passenger ships

4.14.2.1 Watertight bulkheads

- .1 The survey of watertight bulkheads and arrangements consists of:
 - examination, as far as practicable, of collision and watertight bulkheads, and confirmation that their watertight integrity has not been impaired;
 - checking the diagram provided on the navigation bridge showing the location

of the watertight doors and related indicators for their open/closed position;

- testing operation of local and remote control (from the navigation bridge) of the watertight doors, and in particular, operation from each side of the bulkhead of audible alarms or visual signals and control handles, as required or fitted;
- confirmation of operation of watertight doors in the event of failure of main and emergency sources of power;
- conformation that electrical motors associated circuits and control components are protected to IPX7 standard;
- confirmation that notices are affixed at appropriate locations.

4.14.2.2 Openings in shell plating

- .1 The survey consists of:
 - examination of the arrangements for closing sidescuttles and their deadlights, as well as scuppers, sanitary discharges and similar openings and other inlets and discharges in the shell plating below the margin line,
 - examination of the door position indicators and associated circuits and control components are protected to IPX8 standard as well as door movement warning signals are protected to IPX6 standard,
 - confirmation that valves for closing the main and auxiliary sea inlets and discharges in the machinery spaces are readily accessible, and that indicators showing the status of the valves are provided, as required or fitted;
 - confirmation that gangway access and cargo ports fitted below the margin line may be effectively closed and that the inboard ends of any ash or rubbish chutes are fitted with an effective cover.

4.14.2.3 Miscellaneous

It is to be verified that the emergency escape routes from passenger and crew space, including related stairways and ladders, are kept clear.

4.14.3 Ro-Ro passenger ships

- .1 The scope of the annual survey and class renewal survey of Ro-Ro passenger ship is to include the scope of surveys required for the service notations Ro-Ro cargo ship and passenger ships, as detailed in 4.14.1 and 4.14.2.
- .2 In addition to .1, the condition of means of escape as well as of fire protection, detection and extinction in special category spaces is to be checked.

4.15 ADDITIONAL ANNUAL SURVEY REQUIREMENTS FOR TECHNICAL FLOATING UNITS

Following requirements apply to type notations **split hopper barge, dredger, self-unloading hopper barge**. Examinations according to the requirements stated in 4.2 and 4.4 are to be fulfilled as far as applicable.

4.15.1 The survey is to include the following items, as far as required or fitted, according to the service notation of the ship:

- .1 for **split hopper barge** (split hopper unit), visual examination, as far as practicable, of superstructure hinges and blocks, deck hinges, hydraulic jacks and associated piping systems and alarms,
- .2 for **dredger, self-unloading hopper barge, split hopper barge**:
 - a) visual examination, as far as practicable, of attachments of suction piping and lifting systems to the structure and external examination of piping in dredging machinery spaces for absence of corrosion and leakage,
 - b) checking the condition of the dredging machinery space and related equipment with regard to electrical shocks, protection from rotating machinery, fire and explosion hazards.

4.16 ADDITIONAL ANNUAL SURVEY REQUIREMENTS FOR TUGS AND SUPPLY VESSELS

Following requirements apply to type notations **tug** and **supply vessel**. Examinations according to the requirements stated in 4.2 and 4.4 are to be fulfilled as far as applicable.

4.16.1 The surveys are to include a general external examination of the towing hook or towing winch, as fitted, and unhooking device, as far as practicable.

For vessels with additional class notation **FIR** the survey is also to include examination of the fixed self-protection water-spraying system, the water fire extinguishing systems and/or foam fire-extinguishing systems, including the fireman's outfits and the compressor.

4.17 ADDITIONAL ANNUAL SURVEY REQUIREMENTS FOR FISHING VESSELS

Examinations according to the requirements stated in 4.2 and 4.4 are to be fulfilled as far as applicable.

4.17.1 The survey is to include:

- .1 General examination of areas subject to damage, corrosion or wastage, such as the stern ramp, weather deck in way of the working area of the nets, connections to

hull structure of masts, gantries, winches and traw gallows (for side trawlers).

- .2 General examination of the measures for the protection of the crew against falling overboard, such as storm rails, means of protection near stern ramp, etc.

4.18 ADDITIONAL ANNUAL SURVEY REQUIREMENTS FOR ASPHALT CARRIERS

4.18.1 In the case of double hull asphalt carriers, intended for the carriage of cargo in integral tanks, hull Annual survey requirements for double-hull oil tankers should apply (*Rules for the classification of ships, Part 1 – General requirements, Chapter 5 – Surveys of ships in service, Annex B*).

In the case of single hull asphalt carrier intended for the carriage of cargo in integral tanks, requirements for hull Annual survey requirements for single hull tankers, as stated in 4.5 should apply.

In the case of asphalt carriers intended for the carriage of cargo in independent tanks requirements for the hull Annual survey applicable for all ships, as stated in 4.2 should apply.

4.18.2 In addition to the requirements stated in 4.18.1 the following items are to be surveyed also, as being specific for asphalt carriers.

Hull and hull equipment

- 4.18.2.1** The survey of weather decks is to include:
- .1 Examination of cargo tank openings, including gaskets, covers, coamings and screens.
 - .2 Examination of cargo tank pressure / vacuum valves and flame screens.
 - .3 Examination of flame screens on vents to all fuel tanks.
 - .4 Examination of cargo, fuel, ballast, and vent piping systems, including remote control valves, safety valves and various safety devices.
 - .5 Confirmation that pumps, valves and pipelines are identified and distinctively marked.

4.18.2.2 The survey of cargo pump rooms and pipe tunnel is to include:

- .1 Examination of all pump room bulkheads and pipe tunnels (if any) for signs of cargo leakage or fractures and in particular, the sealing arrangements of penetrations in pump room bulkheads.
- .2 Examination of the condition of all piping systems, in cargo pump rooms and pipe tunnels (if any).
- .3 Examination of the bilge and ballast arrangements and confirmation that pumps and pipelines are identified.

4.18.2.3 The survey of independent cargo tanks is to include, as far as practicable:

- .1 General external examination of the structure surrounding the tanks for signs of damage, cracks, or deterioration.
- .2 Examination of the thermal isolating material and elements supporting and/or securing the cargo tanks.

4.18.2.4 It is to be verified that the loading manual is available onboard.

Machinery, electrical equipment, and fire protection

4.18.2.5 The survey of cargo area and cargo pump rooms is to include:

- .1 Confirmation that potential sources of ignition in or near the cargo pump rooms, such as loose gear, excessive product in bilge, excessive vapours, combustible materials, are eliminated and that access ladders are in satisfactory condition.
- .2 Examination, as far as practicable, of cargo, bilge, ballast and stripping pumps for excessive gland seal leakage, verification of proper operation of electrical and mechanical remote operating and shutdown devices.
- .3 Checking that pump foundations are intact.
- .4 Confirmation that the ventilation system, including portable equipment, if any, of all spaces in the cargo area (including cargo pump room) is operational and that ducting is intact, and screens are clean.
- .5 Confirmation that electrical equipment in cargo pump rooms and other spaces is in satisfactory condition and has been properly maintained.
- .6 Confirmation that the remote operation of the cargo pump room bilge system is satisfactory.
- .7 Examination of the cargo heating system.
- .8 Examination of the cargo-transfer arrangement and confirmation that any hoses are suitable for their intended purpose and, where appropriate, type approved and marked with the date of testing.

4.18.2.6 The survey of instrumentation and safety devices is to include, as far as applicable:

- .1 Examination of cargo tank gauging devices.
- .2 Confirmation that installed pressure gauges on cargo discharge lines are properly operational.
- .3 Confirmation that devices provided for measuring the temperature of the cargo operate satisfactorily.

- .1 Visual inspection of the battery system. Verify that there are no visible equipment damages, check installation area.
- .2 Functional test with batteries charging and discharging, EMS test.
- .3 Battery system operation and maintenance logs. If batteries are damaged, faulty or with deteriorated capacity and/or state of health, they must be replaced. Any changes of the battery system must be documented.
- .4 Battery system shutdown arrangements.
- .5 Alarms and safety functions.
- .6 Temperature monitoring, ventilation and closing appliances, gas detection and fire detection systems.
- .7 Fire-extinguishing system.

4.19 ADDITIONAL ANNUAL SURVEY REQUIREMENTS FOR THE VESSELS WITH ADDITIONAL CHARACTER OF CLASS “BAT” ASSIGNED

4.19.1 At each Annual survey the following items must be checked:

5 INTERMEDIATE SURVEY

5.1 GENERAL

5.1.1 Intermediate surveys are to be held concurrently with statutory Annual or Intermediate surveys whenever practicable. The Intermediate survey is to be carried out either at or between the second and third Annual survey. Those items which are additional to the requirements of the Annual survey may be surveyed either at or between the second or third Annual survey. A survey meeting is to be held prior to the commencement of the survey. Concurrent crediting to both Intermediate survey and Renewal survey for surveys and thickness measurements of spaces are not acceptable.

For Intermediate survey requirements of IMO Res. [A.1186\(33\)](#) “Survey Guidelines Under the Harmonized System of Survey and Certification, (HSSC) 2023”, which are, as a minimum, to be covered by classification surveys, refer to IACS UR Z1.

For additional Intermediate survey requirements for fuel installations on ships other than liquified gas carriers utilizing gas or other low-flash point fuel refer to Annex E of this Chapter of the Rules.

NOTE: Reporting on existence of asbestos on board

When classification surveys are performed concurrently with statutory surveys, under IACS PR 41 it is ensured that the Organisation responsible for the issue of the Passenger Ship Safety Certification (PSSC), Cargo Ship Safety Construction (SAFCON) Certification or Cargo Ship Safety Certification (CSSC) of the ship and the flag Administration, as appropriate, are notified when the existence of asbestos on board is identified by another Class Society who carries out a survey or audit onboard, for example IHM, ISM or MLC.

5.2 HULL AND HULL EQUIPMENT SURVEY - ALL SHIPS

5.2.1 Survey according to basic and additional requirements stated in 4.2 are to be carried out, as far as applicable, relating to the type of ship and its age.

5.2.2 In addition to above mentioned, requirements stated in Table 5.2-1 are to be carried out, as far as applicable, for the self-propelled steel vessels of 100 GT and above.

5.2.3 Additional requirements for the survey of anchoring and mooring equipment stated in 4.2.1.4 are to be complied with.

5.3 MACHINERY, ELECTRICAL EQUIPMENT AND FIRE PROTECTION ARRANGEMENTS - ALL SHIPS

5.3.1 For the machinery, electrical equipment and fire protection arrangements, the Intermediate survey is to be consisted primarily of the provisions of Annual surveys listed in 4.4 so far as applicable.

All boilers having working pressure exceeding 3,5 bar and a heating surface exceeding 4,5 m², are to be surveyed internally twice in every five-year period (usually during intermediate and Renewal survey). The period between

surveys will not exceed 3 years. An extension of examination of the boiler of up to 3 months beyond the due date can be granted in exceptional circumstances (see the *Rules for the classification of ships, Part 1- General requirements, Chapter 1 – General information*, 5.5.1).

5.3.2 For all ships the electrical generating sets are to be examined under working conditions.

NOTE: Survey of fire protection systems and appliances shall be carried out taking into account applicable Flag Administration requirements, such as MSC.1/Circ.1432 (Revised Guidelines for the maintenance and inspection of fire protection systems and appliances), as amended by MSC.1/Circ.1516.

NOTE: For the requirements for the maintenance and inspection of fixed carbon dioxide fire-extinguishing systems at the intermediate survey see also MSC.1/Circ.1318/Rev.1 - “Revised Guidelines for the maintenance and inspection of fixed carbon dioxide fire-extinguishing systems”, if requested by the Flag State.

5.4 ADDITIONAL INTERMEDIATE SURVEY REQUIREMENTS FOR OIL TANKERS WITH AFFIXED ESP NOTATION OTHER THAN DOUBLE HULL OIL TANKERS

5.4.1 The surveys according to the provisions of 4.5, 5.2 and 5.3 are to be carried out so far as applicable.

Requirements stated in Table 5.2-1 are to be carried out.

In application, for oil tankers 10 to 15 years of age, an in-water survey may be considered.

In application, for oil tankers exceeding 15 years of age, a survey in dry dock is to be part of the intermediate survey. The overall and close-up survey and thickness measurements, as applicable, of the lower portions of the cargo tanks and ballast tanks are to be carried out in accordance with the applicable requirements for intermediate surveys, if not already performed.

NOTE: Lower portions of the cargo holds, and ballast tanks are considered to be the parts below light ballast water line.

5.4.2 For weather decks, an examination as far as applicable of cargo, crude oil washing, bunker, ballast, steam and vent piping on the weather decks, as well as vent masts and headers is to be carried out.

If upon examination there is any doubt as to the condition of the piping, the piping may be required to be pressure tested, gauged, or both.

5.4.3 A general examination of the electrical equipment and cables in dangerous zones such as cargo pump rooms, and areas adjacent to cargo tanks for defective explosion-proof lights and fixtures, improperly installed wiring, non-approved lighting and fixtures and dead end wiring and testing of the insulation resistance of the circuits is to be carried out (see also NOTE in 11.2.1).

In cases where a proper record of testing is maintained, consideration may be given to accepting recent readings. If any readings are marginal or if the condition of the cables, fixtures or equipment appears defective in any way, verification measurements may be required. These measurements are not to be attempted until the ship is in gas free con-

dition and are to be carried out within an acceptable time period.

5.4.4 The survey extent of cargo and ballast tanks dependent on the age of the ship is specified in Table 5.4-1.

Table 5.2-1

Intermediate survey of hull – all ships

For additional requirements for oil tankers, ore/bulk/oil ships and ore/oil ships see Table 5.4.1 and for general dry cargo ships see Table 5.8.1

Ships from 5 to 10 years of age	Ships older than 10 years	Dry cargo ships over 15 years old
<ol style="list-style-type: none"> 1. For ships over 5 years of age, a general, internal examination of representative ballast tanks is to be carried out. If there is no hard protective coating, soft or semi-hard coating, or POOR coating condition, the examination is to be extended to other ballast tanks of the same type. 2. Suspect areas identified at previous surveys are to be examined. Thickness measurements are to be taken of the areas of substantial corrosion (identified at previous surveys) and the extent of thickness measurements is to be increased to determine areas of substantial corrosion. Table 7.2.1-3a may be used as guidance for these additional thickness measurements. These extended thickness measurements are to be carried out before the intermediate survey is credited as completed. 3. In addition, where required by B), internal examination of applicable ballast tanks is to be carried out. When considered necessary by the Surveyor, or where extensive corrosion exists, thickness measurement is to be carried out. 	<ol style="list-style-type: none"> 1. For ships over 10 years of age, a general, internal examination of all ballast tanks is to be carried out (see Notes). 2. Suspect areas identified at previous surveys are to be examined. Thickness measurements are to be taken of the areas of substantial corrosion (identified at previous surveys) and the extent of thickness measurements is to be increased to determine areas of substantial corrosion. Table 7.2.1-3a may be used as guidance for these additional thickness measurements. These extended thickness measurements are to be carried out before the intermediate survey is credited as completed. 3. In addition, where required by B), internal examination of applicable ballast tanks is to be carried out. When considered necessary by the Surveyor, or where extensive corrosion exists, thickness measurement is to be carried out. 4. The anchors are to be partially lowered and raised using the windlass. 5. In the case of ships over 10 years of age, other than ships engaged in the carriage of dry cargo cargoes only or other than oil tankers, chemical tankers and double hull oil tankers, an internal examination of selected cargo spaces is to be carried out. 	<ol style="list-style-type: none"> 1. As for ships over 10 years of age. 2. In the case of dry cargo ships over 15 years old, other than bulk carriers or general dry cargo ships, an internal examination of selected cargo holds is to be carried out.

NOTES:

- A) If such examination reveals no visible structural defects the examination may be limited to a verification that the protective coating remains effective.
- B) For ballast tanks, excluding double bottom tanks, if there is no hard protective coating, soft or semi-hard coating, or POOR coating condition, and it is not renewed, the tanks in question are to be internally examined at annual intervals. When such conditions are found in double bottom ballast tanks, the tanks in question may be internally examined at annual intervals.

Table 5.4-1
Additional requirements for Intermediate survey of hull - oil tankers with affixed ESP notation

Oil tankers 5 - 10 years of age	Oil tankers over 10 years of age
<p>1. All Ballast Tanks are to be examined. When considered necessary by the Surveyor, thickness measurement and testing are to be carried out to ensure that the structural integrity remains effective.</p>	<p>1. The requirements of the Intermediate Survey are to be to the same extent as the previous Renewal Survey as required in 7.7.1.1 to 7.7.1.7.1, 7.7.2, 7.7.4, 7.7.5, and 3.3.2. However, pressure testing of cargo and ballast tanks and the requirements for longitudinal strength evaluation of Hull Girder as required in 7.7.2.4 are not required unless deemed necessary by the attending Surveyor. See also 5.4.1</p>
<p>NOTES:</p> <p>A) A Ballast Tank is to be examined at subsequent annual intervals where:</p> <ul style="list-style-type: none"> - a hard protective coating has not been applied from the time of construction, or - a soft or semi-hard coating has been applied, or - substantial corrosion is found within the tank, or - the hard protective coating is found to be in less than GOOD condition and the hard protective coating is not repaired to the satisfaction of the Surveyor, or <p>B) In addition to the requirements above, suspect areas identified at previous surveys are to be overall and close-up surveyed.</p>	

5.4.5 For ships over ten (10) years of age machinery and boiler spaces including tank tops, bilges and cofferdams, sea suction and overboard discharges are to be generally examined.

5.4.6 For oil tankers, the fixed fire-fighting system for the cargo pump rooms is to be examined, and it is to be confirmed that, as appropriate, any foam compounds have been checked and that the distribution pipework has been proved clear.

5.4.7 For the crude oil washing system the following is to be examined:

- .1 The crude oil washing piping outside the cargo tanks. If upon examination there are any doubt as to its condition, the piping may be required to be pressure tested, gauged or both. Particular attention should be paid to any repairs such as welded doublers.
- .2 The satisfactory operation of the isolation valves to steam heaters for washing water, when fitted, is to be confirmed.
- .3 At least two selected cargo tanks for the express purpose of verifying the continued effectiveness of the installed crude oil washing and stripping systems.
- .4 The manual and/or remote operation of the individual tank valves (or other similar closing devices) to be kept closed at sea.

5.5 ADDITIONAL INTERMEDIATE SURVEY REQUIREMENTS FOR BULK CARRIERS WITH AFFIXED ESP NOTATION

5.5.1 The requirements of Annex C1 are to be complied with as applicable.

5.6 ADDITIONAL INTERMEDIATE SURVEY REQUIREMENTS FOR ASPHALT CARRIERS

5.6.1 In the case of double hull asphalt carriers, intended for the carriage of cargo in integral tanks, hull Intermediate survey requirements for double-hull oil tankers should apply (*Rules for the classification of ships, Part 1 – General requirements, Chapter 5 – Surveys of ships in service, Annex B*).

In the case of single hull asphalt carrier intended for the carriage of cargo in integral tanks, requirements for hull Intermediate survey requirements for single hull tankers, as stated in 5.3 should apply.

In the case of asphalt carriers intended for the carriage of cargo in independent tanks requirements for the hull Intermediate survey applicable for all ships, as stated in 5.2 should apply.

5.6.2 These survey requirements are considered to be additional to those applicable to Annual survey, 4.18.

5.6.3 In addition to the requirements stated in 5.6.1 (and 5.6.2) the following items are to be surveyed also, as being specific for asphalt carriers:

- .1 Cargo, stripping, fuel, ballast, heating, and vent piping systems are to be examined. If upon examination there is any doubt as to the condition of the piping, pressure testing, thickness measurement or both may be required.

5.7 ADDITIONAL INTERMEDIATE SURVEY REQUIREMENTS FOR CHEMICAL TANKERS

5.7.1 The survey is to consist of the provisions of 4.7, 5.2 and 5.3 so far as applicable (for chemical tankers with affixed **ESP** notation see also Annex A).

5.7.2 Vent line drainage arrangements are to be examined.

5.7.3 It is to be verified that, where applicable, pipelines and independent cargo tanks are electrically bounded to the hull.

5.7.4 It is to be confirmed that spares are provided for cargo area mechanical ventilation fans.

5.7.5 It is to be verified from the cargo record book that the pumping and stripping arrangements have been emptying the tanks efficiently and are all in working order.

5.7.6 It is to be confirmed, if possible that the discharge outlet(s) are in good condition.

5.7.7 The satisfactory operation of the recording device is to be confirmed, as fitted, and it is to be verified by an actual flow test that has an accuracy of $\pm 15\%$ or better.

5.7.8 It is to be confirmed that the ventilation equipment for residue removal is satisfactory and that the pressure in the driving medium for portable fans of ventilation equipment for residue removal can be achieved to give the required fan capacity.

5.8 ADDITIONAL INTERMEDIATE SURVEY REQUIREMENTS FOR GENERAL DRY CARGO SHIPS

5.8.1 In addition to the requirements stated in 4.11, 5.2 and 5.3 ballast tanks and cargo holds are to be examined in accordance with Table 5.8-1.

5.9 ADDITIONAL REQUIREMENTS AFTER DETERMINING COMPLIANCE WITH SOLAS 74, CH. II-1/25, FOR GENERAL CARGO SHIPS WITH SINGLE HOLD

5.9.1 For ships less than 80 meters in length, or for ships built before 1 July 1998 less than 100 meters in length, with single hold not protected by double hull, requirements of 4.10.1 apply.

Table 5.8-1
Additional requirements for Intermediate Survey of hull – General dry cargo ships

	5 - 10 years of age	10 - 15 years of age	Over 15 years of age
Ballast tanks	<p>a) An Overall Survey of Representative Spaces selected by the Surveyor is to be carried out. If such inspections reveal no visible structural defects, the examination may be limited to a verification that the corrosion prevention system remains efficient.</p> <p>b) Where POOR coating condition (as defined in 1.2.10), soft or semi-hard coating, corrosion or other defects are found in ballast tanks or where protective coating was not applied from the time of construction, the examination is to be extended to other ballast spaces of the same type. (see also NOTE A)</p> <p>c) In addition to the requirements above, areas found suspect according to 1.2.7 at the previous surveys are to be surveyed in accordance with the provisions indicated in 4.11.2.1</p>	<p>a) For ballast tanks, an overall survey of all tanks is to be carried out. If such inspections reveal no visible structural defects, the examination may be limited to a verification that the corrosion prevention system remains efficient.</p> <p>b) The requirements of b) and c) of general dry cargo ships 5-10 years of age shall apply</p>	<p>a) The requirements of the Intermediate Survey shall be to the same extent as the previous Renewal Survey as required in 7.12.1 to 7.12.4. However, tank testing specified 7.12.4, survey of automatic air pipe heads (see Notes in 7.12.1.5 and 7.12.3), and internal examination of fuel oil, lube oil and fresh water tanks (see 7.12.3) are not required unless deemed necessary by the attending Surveyor.</p> <p>b) In lieu of the requirements of 7.12.1.2, an underwater survey may be considered as equivalent.</p>
Cargo Holds	<p>d) An Overall Survey of one forward and one after cargo hold and their associated 'tween deck spaces.</p> <p>e) Areas found suspect according to 1.2.7 at the previous Renewal Survey.</p>	<p>c) An Overall Survey of all cargo holds and 'tween deck spaces.</p> <p>d) Areas found suspect according to 1.2.7 at the previous surveys.</p> <p>e) When considered necessary by the Surveyor, or where extensive corrosion exists, thickness measurement is to be carried out. If the results of these thickness measurements indicate that Substantial Corrosion is found, then the number of thickness measurements is to be increased to determine the extent of substantial corrosion. Table 7.2.1-3a may be used as guidance for these additional measurements. These extended thickness measurements are to be carried out before the survey is credited as completed.</p>	

NOTES:

A) In ballast tanks other than double bottom tanks, where a hard protective coating is found in POOR condition, and it is not renewed, where soft or semi-hard coating has been applied, or where a hard protective coating was not applied from time of construction, the tanks in question are to be examined and thickness measurements carried out as considered necessary at annual intervals. When such breakdown of hard protective coating is found in ballast double bottom tanks, where a soft or semi-hard coating has been applied, or where a hard protective coating has not been applied, the tanks in question may be examined at annual intervals. When considered necessary by the Surveyor, or where extensive corrosion exists, thickness measurements are to be carried out.

6 BOTTOM SURVEY

6.1 GENERAL

6.1.1 At Docking surveys (see 2.4.1) or in-water surveys (see 2.4.2) the Surveyor is to examine items of the Rules covering hull structures, machinery installations and equipment, so far as necessary and practicable, in order to be satisfied as to the general condition. Special attention is to be paid to the connection between the bilge strakes and the bilge keels.

6.1.2 While docking, as a preparation for painting of the underwater body, and before commencing the survey, the shell is to be thoroughly cleaned, scratched out and all the rust removed.

When a ship is in dry-dock or on a slipway, it is to be placed on blocks of sufficient height and with the necessary staging to permit the examination of elements such as: shell plating including bottom and bow plating, stern frame and rudder, sea chests and valves, propeller, etc. Passages through structures are to be provided, also.

6.1.3 When Docking survey is held concurrently with the Renewal survey all items normally not accessible for the Renewal survey if the ship is not in dry-dock or slipway are to be examined.

6.1.4 For due dates and time intervals regarding Docking survey see Table 6.1-1.

6.2 DOCKING SURVEY

6.2.1 Docking survey of hull for steel ships, aluminium alloy ships

6.2.1.1 The shell is to be examined, which consists of examining the outside ship's bottom and bow plating, keel, bilge keels, stem, stern frame, and all underwater appendages (such as hydrofoils, hydrofoil supports, skirt fixations, shaft brackets, etc.), as far as applicable.

6.2.1.2 Attention is to be given to parts of the structure particularly liable to excessive corrosion or to deterioration from causes such as chafing and lying on the ground, and to any undue unfairness of the plating of the bottom. Special attention is to be paid to the connection between the bilge strakes and the bilge keels. During survey of aluminium alloy ships attention is to be given to the welding, connections of appendages to the hull and visible hull defects or corrosion with surrounding areas.

6.2.1.3 Visible parts of the propeller (main propeller and side thrusters), sternbush and shaft struts are to be examined. The clearance of the sternbush and the efficiency of the oil glands (where applicable) is to be ascertained (see also 10).

Visible parts of side thrusters are to be examined. Other propulsion systems which also have manoeuvring characteristics (such as directional propellers, vertical axis propellers, water jet units) are to be examined externally with focus on the condition of gear housing, propeller blades, bolt locking and other fastening arrangements. Sealing arrange-

ment of propeller blades, propeller shaft and steering column shall be verified (see also 10).

6.2.1.4 Sea chests and their gratings, sea connections and overboard discharge valves and cocks and their fastenings to the hull or sea chests are to be examined. Side valves and cocks are to be opened up. Upon re-assembly the valves should be tested to confirm:

- .1 satisfactory operation of the valves and their actuating mechanisms;
- .2 full closing of the valve;
- .3 tightness of the valve when fully seated. Testing of actuating mechanisms should include the testing of any remote controls e.g. extended spindles, rod gearing.

If the operation of the actuating mechanism is not satisfactory, the mechanism should be further examined to determine the cause, which may include the stripping and opening out of the mechanism as deemed necessary.

Non-metallic expansion joints in piping systems, if located in a system which penetrate the ship's side and both the penetration and the expansion joint are located below the deepest load waterline, shall be examined and replaced if necessary, or at an interval recommended by the manufacturer.

6.2.1.5 The rudder is to be lifted for examination of the pintles if considered necessary by the Surveyor. The clearances of the rudder bearings are to be measured and recorded. Where applicable, pressure test of the rudder may be required as deemed necessary by the Surveyor.

6.2.1.6 At every regular Docking survey for oil tankers and combination carriers five years old and over, a test for insulation resistance is to be made for circuits terminating in, or passing through dangerous zones or spaces (see also NOTE in 11.2.1).

6.2.1.7 When Docking survey is to be held concurrently with the Renewal survey, in addition to previously mentioned, the following requirements are to be fulfilled:

- .1 Sea chests and their gratings, sea connections and overboard discharge valves and cocks and their fastenings to the hull or sea chests are to be examined. Valves and cocks are to be opened up.
- .2 Visible parts of rudder, rudder pintles, rudder shafts and couplings, and securing arrangements are to be examined. If deemed necessary by the Surveyor the rudder is to be lifted.
- .3 The chain cables are to be ranged and examined on all ships over five years old. If any length of chain cable is found to be reduced in mean diameter at its most worn part by 12 per cent or more from its nominal diameter, it is to be renewed. The anchors are to be examined and weighed if considerable deterioration has been noticed. If the weight of the anchor has been reduced by 10 % or more from its nominal weight it is to be renewed.
- .4 Thickness measurements are normally to be carried out in accordance with applicable requirements stated in 7.

6.2.1.8 For all floating units subject to classification by the *Register*, unless otherwise agreed Docking survey is to be conducted at intervals not exceeding 5 (five) years. The *Register* may, upon the owner's request, accept either longer intervals or, for a particular survey, alternative type of survey (e.g. an in-water survey), depending upon the type, intended purpose, and place of anchorage (for alternative type of survey of **floating docks**, see 7.10.4.7 and 7.10.4.8).

6.2.1.9 While performing Docking survey of technical floating units, hopper doors and their fittings, as well as hopper valves are to be checked for proper functioning (see 7.11.4.2).

6.2.1.10 Where a vessel has an **IWS** notation assigned, the conditions of the high resistant paint is to be confirmed at each dry-docking survey in order that the **IWS** notation can be maintained.

6.2.1.11 In addition to the requirements stated in 6.2.1.8, floating units, other than units with type notation **Floating dock**, **Floating storage unit** or **Floating restaurant**, subject to classification by the *Register*, engaged in port areas or other enclosed areas and permanently moored, anchored or based on seabed, are to be drydocked at intervals not exceeding 5 (five) years.

However, in agreement with the *Register*, and if so approved by the Flag State, an in-water survey may be conducted in lieu of a dry-docking survey, confirming the condition of the underwater part of the structure as well as anchoring and mooring system (see 7.11.6).

6.2.2 Docking survey of hull for wooden ships, and fibre reinforced plastic ships

6.2.2.1 The Docking survey of hull for wooden ships consists of:

- .1 Examination of the condition of the outside planking and its caulking on each side of the ship, amidships and at the ends, in the vicinity of the waterline and near to the keel (allowable deterioration of the planking is 25 per cent of its nominal thickness). At the discretion of the attending Surveyor the metal sheathing is to be renewed either entirely or in the deteriorated areas.
- .2 Examination of the condition of the keel, false keel, stem, and sternpost, with a special attention to parts of the structure liable to excessive corrosion or to deterioration from causes such as chafing and lying on the ground.
If the underwater body is protected with fibreglass or other similar materials the Surveyor is to examine adhesion of such material to the shell planking. The Surveyor is also to establish if there are any cracks in before mentioned protection of the underwater body through which the water could penetrate to shell planking.
- .3 During every regular Docking survey examination of all suction and discharge valves, including their fastenings to the hull and gratings is to be performed. When Docking survey is performed concurrently

with the Renewal survey, all suction and discharge valves, including their fastenings to the hull and gratings are to be dismantled, opened up and examined. In the case of cast iron sea valves, or if they are of an unapproved type, they are to be opened up for examination at every regular Docking survey.

- .4 Examination of the bilge system, which is to be opened up, examined and tested under working conditions, as deemed necessary. All sea connections, sludge boxes, strainers and valves related to the system mentioned before are to be opened up and examined. The bilge and ballast piping is to be tested. Additionally, operation of extended spindles and level alarms, where fitted are to be examined, as well as emergency sea inlets.
- .5 Measurement of clearances in the rudder bearings and rudder pintles, as well as the wear down in the rudder carrier bearing and sternbush. If deemed necessary by the Surveyor the rudder is to be lifted. On Simplex type rudder the nut on the end of the rudder stock is to be checked for unscrewing because of the vibration.
- .6 Examination of the propellers and propeller shafts is to be conducted in accordance with the requirements stated in 10.
- .7 Examination of the grounding plates (for lightning-conductor, radio, and electrical equipment).
- .8 For fiber-reinforced plastic ships the overall hull survey is to be carried out to determine visible signs of lining deterioration from causes such as chafing and lying on the ground. Additionally, the underwater part of the hull is to be surveyed for possible appearance of osmosis.

6.3 IN-WATER SURVEY

6.3.1 Where permitted (see also 2.4.2) the In-water Survey is to be carried out in sheltered water with weak tidal streams and currents. The in-water visibility and the cleanliness of the hull below the waterline is to be clear enough to permit meaningful examination which allows the Surveyor and the in-water survey firm to determine the condition of the plating, appendages and the welding.

The *Register* is to be satisfied with the methods of orientation of the divers or Remotely Operated Vehicle (ROV) on the plating, which should make use, where necessary, of permanent markings on the plating at selected points.



6.3.2 The equipment, procedure for observing and reporting the survey are to be discussed with the parties involved prior to the In-water Survey, and suitable time is to be allowed to permit the in-water survey firm to test all equipment beforehand. The survey is to be carried out under the surveillance of a surveyor by an in-water survey firm approved as a service supplier according to the *Rules for the classification of ships, Part 1- General requirements, Chapter 4 - Approval of manufacturers and service suppliers*. The Sur-

veyor is to be satisfied with the method of pictorial presentation and a good two-way communication between the Surveyor and the divers is to be provided.

6.3.3 Upon completion of the survey the divers shall submit to the Surveyor a detailed report including video tapes.

6.3.4 If the In-water survey reveals damage or deterioration that requires early attention, the Surveyor may require that the ship be dry-docked in order that detailed survey can be undertaken, and the necessary repairs carried out.

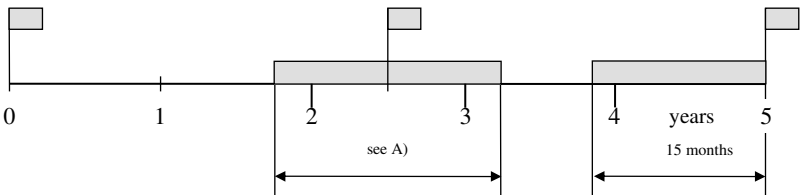
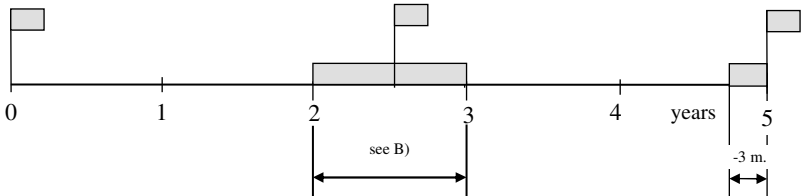
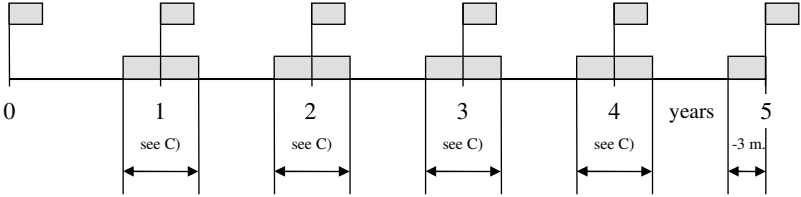
Table 6.1-1
Due dates and time intervals regarding Docking survey

<p>STEEL SHIPS ^{1) 2)}</p>	 <p>A) Survey interval is ± 9 months.</p>
<p>FIBER-REINFORCED PLASTIC AND ALUMINIUM SHIPS ²⁾, WOODEN SHIPS (with age ≤ 10 years)</p>	 <p>B) Survey interval is ± 6 months.</p>
<p>WOODEN SHIPS (with age over 10 years)</p>	 <p>C) Survey interval is ± 3 months.</p>
<p> - due date of the Docking survey</p> <p>¹⁾ For all steel ships there should be a minimum two Docking surveys during each five-year period of validity of the Certificate of Class. In addition to that it is obligatory for the ships with $GT \geq 500$ that one of two Docking surveys is to be performed as a part of the Renewal survey. In all cases the interval between any two such surveys should not exceed 36 months.</p> <p>²⁾ For passenger ships in international navigation an inspection of the ship's bottom is required annually. In a period of five years, two such inspections are to take place out of water. The maximum interval between these inspections is 36 months. IWS may be carried out each year when an inspection out of water is not required. For passenger ships in international navigation older than 15 years, performance of IWS is subjected to special consideration and approval of the <i>Register</i>.</p>	

7 RENEWAL SURVEY

7.1 GENERAL

7.1.1 During Renewal survey the Annual survey requirements (see Section 4) are to be completed with as applicable for all ships (including requirements for additional characters of class, e.g. BAT).

Additional requirements for oil tankers, ore/bulk/oil ships, ore/oil ships, chemical tankers, general dry cargo ships and livestock carriers are given in 7.7, 7.8, 7.12 and 7.13.

For additional Renewal survey requirements for fuel installations on ships other than liquified gas carriers utilizing gas or other low-flash point fuel refer to Annex E of this Chapter of the Rules.

NOTE: Reporting on existence of asbestos on board

When classification surveys are performed concurrently with statutory surveys, under IACS PR 41 it is ensured that the Organisation responsible for the issue of the Passenger Ship Safety Certification (PSSC), Cargo Ship Safety Construction (SAFCON) Certification or Cargo Ship Safety Certification (CSSC) of the ship and the flag Administration, as appropriate, are notified when the existence of asbestos on board is identified by another Class Society who carries out a survey or audit onboard, for example IHM, ISM or MLC.

7.1.2 The requirements for thickness measurement and Close-up survey are given in 7.5 and 7.6.

7.1.3 If docking survey is to be carried out concurrently with the Renewal survey or as a part of the Renewal survey, the requirements stated in 6.2.1.7 are to be complied with.

7.1.4 For preparation, conditions and documentation of survey see 3.2 and 3.3.

7.1.5 Renewal surveys are to be held concurrently with statutory Renewal surveys whenever practicable.

7.2 HULL AND HULL EQUIPMENT REQUIREMENTS - STEEL SHIPS, ALUMINIUM ALLOY SHIPS

7.2.1 General requirements for hull and hull equipment surveys

7.2.1.1 The Renewal survey is to include, in addition to the requirements of the Annual survey (see 4.2), examination, tests and checks of sufficient extent to ensure that the hull, machinery, equipment and related piping (see 7.2.1.10) are in satisfactory condition and fit for the intended purpose for the new period of validity of the Certificate of Class of five years to be assigned, subject to proper maintenance and operation and the periodical surveys being carried out at the due dates.

The examinations of the hull are to be supplemented by testing and thickness measurements (see Table 7.2.1-2 and 7.2.1.9), to ensure that the structural integrity remains effective. The aim of the examination is to discover Substantial Corrosion, significant deformation, fractures, damages or other structural deterioration, that may be present.

Additional hull survey requirements for oil tankers and combination carriers are stated in 7.7 and for general dry cargo ships in 7.12 respectively. For bulk carriers the requirements of Annex C1 or Annex C are to be complied with as applicable.

7.2.1.2 The Company is responsible to prepare the ship for survey in accordance with the requirements stated in 3.2 and Table 7.2.1-1.

7.2.1.3 Anchoring and mooring equipment is to be examined, and the anchors and chain cables are to be ranged, examined and the required complement and condition verified.

Requirements stated in 4.2.1.4 are to be complied with.

The chain locker, holdfasts, hawse pipes and chain stoppers are to be examined and pumping arrangements of the chain locker tested. At second Renewal survey and subsequent Renewal surveys, chain cables are to be gauged and renewed in cases where their mean diameter is worn over 12% (see 6.2.1.7.3).

7.2.1.4 All spaces including holds and their 'tween decks where fitted, double bottom, deep, ballast, peak, and cargo tanks, pump rooms, pipe tunnels, duct keels, machinery spaces, dry spaces, cofferdams and voids are to be internally examined including the plating and framing, bilges and drain wells, sounding, venting, pumping and drainage arrangements.

Internal examination of fuel oil, lube oil and freshwater tanks is to be carried out in accordance with Table 7.2.1-2. At Renewal survey No. 3 and subsequent Renewal surveys, structural downflooding ducts and structural ventilation ducts are to be internally examined.

Engine room structure is to be examined. Particular attention is to be given to tank tops, shell plating in way of tank tops, brackets connecting side shell frames and tank tops, and engine room bulkheads in way of tank top and bilge wells. Particular attention is to be given to sea suction, sea water cooling pipes and overboard discharge valves and their connections to the shell plating. Where wastage is evident or suspect, thickness measurements are to be carried out, and renewals or repairs made when wastage exceeds allowable limits.

Where provided, the condition of corrosion prevention system of ballast tanks is to be examined. For ballast tanks, excluding double bottom tanks, where a hard protective coating is found in POOR condition and it is not renewed, where soft or semi-hard coating has been applied, or where a hard protective coating was not applied from time of construction, the tanks in question are to be examined at annual intervals. Thickness measurements are to be carried out as deemed necessary by the Surveyor.

When such breakdown of hard protective coating is found in ballast double bottom tanks and it is not renewed, where a soft or semi-hard coating has been applied, or where a hard protective coating was not applied from the time of construction, the tanks in question may be examined at annual intervals. When considered necessary by the Surveyor, or where extensive corrosion exists, thickness measurements are to be carried out.

7.2.1.5 Automatic air pipe heads installed on the exposed decks (see 1.2.18) of all ships are to be completely examined (both externally and internally) in accordance with the

requirements of Table 7.2.1-4. For designs where the inner parts cannot be properly inspected from outside, this is to include removal of the head from the air pipe. Particular attention is to be paid to the condition of the zinc coating in heads constructed from galvanised steel. For passenger ships the air pipe heads on Ro-Ro decks are to be examined as for exposed decks.

NOTE: According to IACS Rec.111, for passenger ships, all internal tanks will have air pipes to prevent overpressure or vacuum in case of filling or discharging. Air pipes may end in the engine room for smaller tanks but are normally extended to higher external decks or led directly overboard above the waterline. Where extended to higher decks or led overboard, the air pipes may be crossing other compartments and will, in service or accommodation decks, often be hidden behind panels. Some of the air pipes will be subject to a corrosive environment adversely affecting the pipe itself and also the vent heads.

7.2.1.6 The masts and standing rigging are to be examined.

7.2.1.7 Hull structure below ceiling, insulation, sheathing, and other covering is to be examined in accordance with the requirements of Table 7.2.1-1.

7.2.1.8 Tanks are to be internally examined and tested in accordance with the requirements of Table 7.2.1-2.

7.2.1.9 Thickness measurement is to be carried out in accordance with Table 7.2.1-3 and requirements stated in 7.5.

The Surveyor may extend the thickness measurements as deemed necessary. When thickness measurements indicate Substantial Corrosion, the number of thickness measurements is to be increased to determine the extent of Substantial Corrosion as stated in Table 7.2.1-3a.

Thickness measurements of structures in areas where close-up surveys are required are to be carried out simultaneously with close-up surveys (see 3.2.5).

7.2.1.10 All bilge and ballast piping systems are to be examined and operationally tested to working pressure to attending Surveyor's satisfaction to ensure that tightness and condition remain satisfactory.

7.2.1.11 Emergency towing arrangements on oil and chemical tankers with DWT \geq 20,000 are to be examined.

7.2.2 Hatch covers and coamings

7.2.2.1 In addition to thorough survey of all applicable items, in accordance with stated in 4.2.2, including close-up survey of hatch cover plating and hatch coaming plating, is to be carried out. Subject to cargo hold hatch covers of approved design which structurally have no access to the internals, close-up survey shall be done of accessible parts of hatch covers structures. Checking of the satisfactory operation of all mechanically operated hatch covers is to be carried out including:

- .1 Stowage and securing in open condition.
- .2 Proper fit and efficiency of sealing in closed condition.
- .3 Operational testing of hydraulic and power components, wires, chains, and link drives.

7.2.2.2 Checking the effectiveness of sealing arrangements of all hatch covers by hose testing or equivalent is to be carried out.

7.2.2.3 For bulk carries thickness measurement of hatch covers and coaming plating and stiffeners is to be carried out in accordance with the requirements of Table 7.2.2-1. For general dry cargo ships close-up survey and thickness measurement of hatch cover and coaming plating and stiffeners is to be carried out in accordance with the requirements of Table 7.12.3-1 and Table 7.12.2-1.

7.2.2.4 For container ships in addition to aforementioned the following is to be carried out:

- .1 checking for cracks and deformations of the container supporting elements (weld-in elements) in the inner bottom and in hatch covers, of supporting legs arranged on deck, if any, and of the entire hatch covers,
- .2 checking of condition and operability of supports and stoppers of hatch covers,
- .3 survey of guide rails and supporting frames if fitted (connection to hull, deformations),
- .4 random checking of the (loose) stowage and lashing elements, comparison with the certificates kept in the ship's files.

7.2.3 Bow doors, inner doors, side shell doors and stern doors on Ro-Ro passenger ships

7.2.3.1 The Renewal survey is to include, in addition to the requirements of the Annual Survey as required in 4.14.1.1, examination, tests and checks of sufficient extent to verify that the bow, inner, side shell and stern doors, are in satisfactory condition and considered able to remain in compliance with applicable requirements, subject to proper maintenance and operation in accordance with the Operation and Maintenance Manual (OMM) or manufacturer's recommendations and the periodical surveys being carried out at the due dates for the five year period until the next Renewal survey.

The examinations of the doors are to be supplemented by thickness measurements and testing to verify compliance with applicable requirements so that the structural and weathertight integrity remain effective. The aim of the examination is to identify corrosion, significant deformation, fractures, damages, or other structural deterioration, that may be present.

7.2.3.2 The bow, inner, side shell and stern doors are to be surveyed as follows:

- .1 A survey of the items listed in 4.14.1.1.4 and 4.14.1.1.5 is to be carried out
- .2 Non-destructive testing and thickness measurements are to be carried out on securing, supporting, and locking devices, including welding, to the extent considered necessary by the surveyor. Whenever a crack is found, an examination with NDT is to be carried out in the surrounding area and for similar items as considered necessary by the surveyor.
- .3 The maximum thickness diminution of hinging arms, securing, supporting and locking devices is to be treated according to the normal procedure for primary structures, but is not to be more than 15% of the

as-built thickness or the maximum corrosion allowance, whichever is less. Certain designs may be subject to a special consideration by the *Register*.

- .4 Checking the effectiveness of sealing arrangements by hose testing or equivalent is to be carried out.
- .5 Clearances of hinges, bearings and thrust bearings are to be taken. Unless otherwise specified in the OMM or by manufacturer's recommendation, the measurement of clearances on Ro-Ro cargo ships may be limited to representative bearings where dismantling is needed in order to measure the clearances. If dismantling is carried out, a visual examination of hinge pins and bearings together with NDT of the hinge pin is to be carried out.
- .6 The non-return valves of the drainage system are to be dismantled and examined.

7.2.4 Aluminium alloy ships

7.2.4.1 For aluminium alloy ships the survey is to be supplemented with thickness measurements of structural elements, shell plating and stiffeners, where substantial damages or defects due to corrosion or galvanic current is found.

Thickness measurements are to be carried out on following positions:

- .1 Suspect areas throughout the ship.
- .2 Stern shell plating and shell plating in way of engine rooms.

Structural elements, plating, and stiffeners where the survey revealed damage, wastage, or thickness diminution over allowable limits, are to be renewed to the original thickness at the Surveyors satisfaction.

On positions where high structural strain is possible, detailed survey is to be carried out, and if deemed necessary supplemented with a non-destructive examination. Where the survey reveals structural defects, repairs are to be carried out promptly and thoroughly.

Special attention is to be given to the corners of openings and other structural discontinuities.

7.2.5 Surveys of Watertight Cable Transits

7.2.5.1 These requirements apply to all vessels with GT ≥ 500 and navigation g on international voyages, contracted for construction on or after 1st July 2021. A Cable Transit Seal Systems Register is to be provided by the shipbuilder for all watertight cable transits fitted to the vessel.

7.2.5.2 The requirements for Renewal Survey may be undertaken by the attending Surveyor or by a firm approved as a service supplier.

7.2.5.3 All transits are to be examined to confirm their satisfactory condition and the Cable Transit Seal Systems Register is to be reviewed to confirm it is being maintained. The Renewal Survey is to be recorded in the Cable Transit Seal Systems Register, in which a single record entry will be sufficient to record the survey of all transits.

7.2.5.4 From review of the Cable Transit Seal Systems Register, where there are records entered since the last Renewal survey of any disruption to the cable transits or installation of new cable transits (except which are reviewed and examined at previous annual surveys), the satisfactory condition of those transits is to be confirmed by the attending Surveyor by review of records and examination of the transits; the results are to be recorded in the Cable Transit Seal Systems Register against each of those cable transits.

7.2.5.5 In case the cable transits have been examined by an approved service supplier, the attending surveyor is to review the Cable Transit Seal Systems Register in order to ascertain that it has been properly maintained by the owner and correctly endorsed by the service supplier.

7.3 HULL, HULL EQUIPMENT AND MACHINERY REQUIREMENTS - WOODEN SHIPS, AND FIBRE REINFORCED PLASTIC SHIPS

7.3.1 The rigidity, i.e. the extent and the type of the Renewal survey for wooden ships is to be determined according to the ship's age and used type of timber and material for fastenings.

7.3.2 For Renewal survey of ships up to twenty (20) years of age the following is to be fulfilled, as far as applicable:

- .1 Requirements stated in 4.3 and 6.2.2 are to be fulfilled.
- .2 Any surfaces in contact with rust are to be well scraped and the outside surface of the shell planking, from the light waterline to the covering boards, is to be cleaned and scrapped. Additionally, if considered necessary by attending Surveyor sufficient amount of ceiling and limber boards is to be removed. Additionally, if considered necessary by the Surveyor sufficient amount of the outer shell planking, inner sparing and metal sheathing if any is to be removed to enable a close examination of the structure.
- .3 The sheerstrake planking is to be examined and, if considered necessary by attending Surveyor, tested by drawing a sufficient number of tree nails, or by boring if no tree nails are fitted. The holes resulting from the latter are to subsequently to be closed by tree nails or bolts.
- .4 Particular attention is to be given to the planking on the upper deck or weather deck. Special attention is to be given to the planking adjacent to pillars and areas near windlasses and hatchway openings, as well as to the areas near deck transverses and longitudinals. When necessary metal sheathing in chain locker is to be examined, and if considered necessary by attending Surveyor, a certain amount of such metal sheathing is to be removed in order to establish the condition of the structure

- below, in extent as deemed necessary by the attending Surveyor.
- .5 If examination reveals rot or decay due to woodworm, the affected areas are to be renewed. Planks showing evident signs of wear are to be bored and renewed either wholly or partially when the deterioration exceeds 20 [mm] or if it is worn by 25 per cent or more from its required nominal thickness.
 - .6 Where the keel and centre keelson are connected by iron fastenings, a sufficient number of such fastenings is to be drawn to check their condition (all worn out fastenings are to be renewed), where this is impracticable, additional fastenings, as required by the Surveyor are to be fitted in the connection of keel with centre keelson, of stem and sternpost with aprons and inner sternposts, and also in the connection of other main structural members.
 - .7 Particular attention is to be given to the examination of breasthooks, frames, beams (particularly at their ends), knees, hawse timbers, knight heads, transoms, and all fore and aft structural members.
 - .8 Where steel brackets are not sticking well enough to the inner ceiling or beams, they are to be stuck by hammers.
 - .9 Bulwarks, bulwark stays, guard-rails and similar fittings, and superstructures in general are to be examined in order to check their condition.
 - .10 Cargo holds, bulkheads, and bulkhead openings are to be examined.
 - .11 The watertightness of hatch covers is to be checked by testing with water spilling.
 - .12 Engine foundations in the machinery spaces are to be examined. Additionally, all structural elements made of steel (including parts of engine foundations) are to be well cleaned and the rust has to be removed before painting.
 - .13 Masts, mast's armature, and standing and loose rigging are to be visually examined, as well as the fastening of the mast to the structure.
 - .14 Anchors, chain-cables, shackles, hooks, bolts and all other similar arrangements used for connecting anchors to anchor chains are to be visually inspected for wear and tear. Any length of chain-cable which is found to be reduced in mean diameter at its most worn part by 12 per cent or more from its required nominal diameter should be renewed.
 - .15 The rudder is to be thoroughly examined and, if deemed necessary by the Surveyor, it is to be lifted for the examination of the pintles. Rods, chains, ropes, sheaves, pins and rollers related to steering gear are to be examined for wear and tear.
 - .16 Main and auxiliary steering gears are to be carefully examined and tested under work-

ing conditions. If considered necessary by the Surveyor, they are to be opened up in extent deemed appropriate.

- .17 Ropes intended for mooring and towing are to be checked.
- .18 In addition to the aforementioned examination of main and auxiliary machinery installations in accordance with the requirements stated in 8 is to be fulfilled, in extent as far as applicable:

NOTE: The extent of survey and overhauling of machinery is to be determined by the Surveyor depending on the general condition, number of working hours from the log-book, type of the installation, records from previous surveys, and results of testing under working conditions.

7.3.3 For Renewal survey of ships older than 20 (twenty) years, the following is to be fulfilled, as far as applicable:

- .1 Requirements stated in 7.3.2 are to be fulfilled.
- .2 Nails, bolts, etc. are to be drawn up and examined, but in no case in amount lesser than:
 - a) two bolts connecting keel with centre keelson,
 - b) one bolt from the keelson-scharphs,
 - c) two bolts from the horizontal brackets, starboard and portside, and two bolts from the vertical brackets, starboard and portside,
 - d) two nails or bolts from butts near the keel on each side of the ship, as well as two nails or bolts from butts of the outside planking, starboard and portside.
- .3 Several lengths of covering boards, waterways, as well as inner waterways shall be removed as considered necessary by the Surveyor, in order to carefully check the condition of the timber in way of the ends of beams and frames.
- .4 Superstructures and erections are to be scraped, particularly in those positions which are liable to greater deterioration, and parts are to be removed as required for renewal and/or repair.
- .5 The heel of the mast is to be checked, as well as its penetrations through decks (one or two wedgings are to be removed). Visual inspection of the mast is to be performed in order to establish possible transverse cracks. If visual examination or testing by sounding of the mast reveals woodworm or other holes, not affecting the strength of the mast, they are to be closed, in order to prevent penetration of the water and possible rotting or decay of the mast. Standing and loose rigging, as well as mast's armature are to be dismantled if considered necessary by attending Surveyor. Sails and spare sails are to be examined.

- .6 The windlass and other items of the deck machinery are to be examined and dismantled as deemed necessary by the Surveyor.

7.3.4 For ships with hull made of plywood (stiffened wood) or with wooden hull covered with protective lining or covering, following is to be carried out and, where necessary, repairs are to be carried out to the Surveyors satisfaction:

- .1 Attention is to be given to the condition of edge protection as well as of protective lining, and also to establish cracks where water may enter under protective lining/covering.
- .2 Establishing possible de-lamination between layers.

7.3.5 For fiber-reinforced plastic ships the survey is to be performed to find possible alterations of surface condition or damages from causes such as chafing and lying on the ground. Where the survey reveals structural defects, repairs are to be carried out to the Surveyors satisfaction. The Surveyor may request for grinding of suspect areas or for taking of hull structure samples as well as for measuring of the moist percentage in hull structure.

Special attention is to be given to the positions where high structural strain is possible, corners of openings and other structural discontinuities.

7.4 FIRE PROTECTION - ALL SHIPS

7.4.1 The survey in accordance with the requirements stated in 4.4.2 is to be carried out.

NOTE: Survey of fire protection systems and appliances shall be carried out taking into account applicable Flag Administration requirements, such as MSC.1/Circ.1432 (Revised Guidelines for the maintenance and inspection of fire protection systems and appliances), as amended by MSC.1/Circ.1516.

NOTE: For the requirements for the maintenance and inspection of fixed carbon dioxide fire-extinguishing systems see also MSC.1/Circ.1318/Rev.1 (Revised Guidelines for the maintenance and inspection of fixed carbon dioxide fire-extinguishing systems), if requested by the Flag State.

7.4.2 It is to be confirmed that minimum recommended maintenance is carried out by the service supplier as follows.

At least biennially (intervals of 2 years \pm 3 months) in passenger ships or at each intermediate or renewal survey in cargo ships, the following maintenance is to be carried out:

- .1 all high-pressure cylinders and pilot cylinders should be weighed or have their contents verified by other reliable means to confirm that the available charge in each is above 90 % of the nominal charge. Cylinders containing less than 90 % of the nominal charge should be refilled. The liquid level of low-pressure storage tanks should be checked to verify that the required amount of CO₂ to protect the largest hazard is available;
- .2 the hydrostatic test date of all storage containers should be checked. High pressure cylinders should be subjected to periodical

tests at intervals not exceeding 10 years. At the 10-year inspection, at least 10% of the total number provided should be subjected to an internal inspection and hydrostatic test. If one or more cylinders fail, a total of 50% of the onboard cylinders should be tested. If further cylinders fail, all cylinders should be tested. Flexible hoses should be replaced at the intervals recommended by the manufacturer and not exceeding every 10 years; and

- .3 the discharge piping and nozzles should be tested to verify that they are not blocked. The test should be performed by isolating the discharge piping from the system and flowing dry air or nitrogen from test cylinders or suitable means through the piping.

7.4.3 It is to be confirmed that minimum recommended maintenance is carried out by the service supplier as follows.

At least biennially (intervals of 2 years \pm 3 months) in passenger ships or at each renewal survey in cargo ships, the following maintenance is to be carried out:

- .1 where possible, all activating heads should be removed from the cylinder valves and tested for correct functioning by applying full working pressure through the pilot lines.

In cases where this is not possible, pilot lines should be disconnected from the cylinder valves and blanked off or connected together and tested with full working pressure from the release station and checked for leakage.

In both cases this should be carried out from one or more release stations when installed.

If manual pull cables operate the remote release controls, they should be checked to verify the cables and corner pulleys are in good condition and freely move and do not require an excessive amount of travel to activate the system;

- .2 all cable components should be cleaned and adjusted as necessary, and the cable connectors should be properly tightened. If the remote release controls are operated by pneumatic pressure, the tubing should be checked for leakage, and the proper charge of the remote releasing station pilot gas cylinders should be verified. All controls and warning devices should function normally, and the time delay, if fitted should prevent the discharge of gas for the required period; and
- .3 after completion of work the system should be returned to service.

NOTE: In case when Flag State Administration requirements differ from aforementioned, then specific requirements of the Administration shall be applied.

7.4.4 Five-year service. At least once in every five years, an internal inspection of all control valves should be performed.

7.4.5 Fire extinguishers and associated propellant gas cylinders if any are to be subject to pressure testing every 10 years, by manufacturer or approved firm. At least one extinguisher of each type manufactured in the same year and kept onboard a ship should be test discharged at five yearly intervals (as part of a fire drill).

7.5 THICKNESS MEASUREMENT AND REPORTING

7.5.1 For thickness measurement and reporting see also 3.2.5. For initial requirements while determining parts of ships structure where thickness measurements are to be carried out see 3.1.9.

7.5.2 Thickness measurements required in context of hull structural surveys if not carried out by the *Register* are to be witnessed by a Surveyor on board, while the gauging is taken, to the extent necessary to control the process. The thickness measurement operator is to be part of the survey meeting which is to be held prior to commencing the survey.

7.5.3 Thickness measurements are not to be performed before the fourth Annual survey. Results of such measurement may be accepted for Renewal survey. Concurrent crediting to both Intermediate survey and Renewal survey for surveys and thickness measurements of spaces are not acceptable.

7.5.4 Thickness measurements are to be taken at the forward and aft areas of all plates. Where plates cross ballast/cargo tank boundaries, separate measurements for the area of plating in way of each type of tank are to be reported.

7.5.5 In all cases the measurements are to represent the average of the multiple measurements taken on each plate and/or stiffener.

7.5.6 Where thickness measurement reveal the need for renewal of plates than the thickness of adjacent plates in the same strake is to be reported.

7.5.7 Where two or three transverse sections are required to be measured at least two should be within 0.5L amidships, and where applicable should be in way of a ballast tank.

7.5.8 The Surveyor may require to measure the thickness of the material in any portion of the structure where signs of wastage are evident or wastage is normally found. The Surveyor may further extend the thickness measurements if deemed necessary. When thickness measurements indicate Substantial Corrosion, the number of thickness measurements is to be increased to determine the extent of Substantial Corrosion as stated in Table 7.2.1-3a.

7.5.9 Upon completion of the thickness measurements on board, the attending Surveyor is to confirm that no further gauging is needed or specify additional gauging. The attending Surveyor is also to verify and keep, until review of the final thickness measurement report is completed, a copy of the preliminary thickness measurement report signed by the operator.

A thickness measurement report is to be prepared by a firm whose operators carried out thickness measurements. The report is to give the location of measurements, the thickness measured as well as corresponding original thickness.

Furthermore, the report is to give the date when the measurements were carried out, type of measuring equipment, names of personnel and their qualifications, and be signed by the operator.

The Surveyor is to review the final thickness measurement report and countersign the cover pages.

7.5.10 The thickness measurements may be specially considered (see 1.2.13), provided the Surveyor is satisfied by the Close-up examination, that there is no structural diminution, and the protective Coating where applied remains efficient.

If extent of thickness measurements has been reduced, the Surveyor's special consideration is to be reported.

7.5.11 The minimum requirements for thickness measurements are given in 7.2.1.9 and 7.7.2.

7.5.12 Thickness measurements of structures in areas where close-up surveys are required are to be carried out simultaneously with close-up surveys (see 3.2.5).

7.6 CLOSE-UP SURVEY

7.6.1 For initial requirements while determining parts of ship's structure where Close-up surveys are to be carried out see 3.1.10, and 7.7.4.

7.6.2 The Surveyor may extend the Close-up survey, if deemed necessary, taking into account the maintenance of the tanks under survey, the condition of the corrosion protection system, and also in the following cases:

- .1 In particular, tanks having structural arrangements or details which have suffered defects in similar tanks or on similar ships.
- .2 In tanks which have structures approved with reduced scantlings in association with an approved corrosion control system.

7.6.3 For areas in tanks where coatings are found to be in GOOD condition, (as defined in 1.2.10) the extent of Close-up survey may be specially considered by the *Register* (see 1.2.13).

7.6.4 For bulk carriers with additional character of class **GRAB** the reinforced area of inner bottom plating, lower part of hopper tank sloping plating and transverse lower stool plating and adjacent associated structures, as applicable, are to be visually examined for possible deformations, fractures or other damage. If deemed necessary, thickness measurement may be required.

7.7 RENEWAL SURVEY ADDITIONAL REQUIREMENTS FOR OIL TANKERS WITH AFFIXED ESP NOTATION OTHER THAN DOUBLE HULL OIL TANKERS

7.7.1 General requirements

7.7.1.1 The survey in accordance with the requirements stated in 4.5, 4.6, 7.2 and 7.4 is to be carried out so far as applicable.

A survey in dry dock is to be a part of the Renewal survey. The overall and close-up surveys and thickness measurements, as applicable, of the lower portions of the cargo tanks and ballast tanks are to be carried out in accordance with the applicable requirements for Renewals surveys, if not already performed.

NOTE: Lower portions of the cargo and ballast tanks are considered to be the parts below light ballast water line.

7.7.1.2 All cargo tanks, ballast tanks including double bottom tanks, pump rooms, pipe tunnels, cofferdams and void spaces bounding cargo tanks, decks and outer hull are to be examined, and this examination is to be supplemented by Close-up survey, thickness measurement and testing as required in 7.7.2 and 7.7.5, to ensure that the structural integrity remains effective.

7.7.1.3 The aim of the examination is to discover Substantial corrosion, significant deformation, fractures, damages or other structural deterioration, that may be present. If deemed necessary by the Surveyor, suitable non-destructive examination may be required (see 3.2.6).

7.7.1.4 For oil tankers cargo piping on deck including Crude Oil Washing (COW) piping Cargo and Ballast piping within the above tanks and spaces are to be examined and operationally tested to working pressure to attending Surveyor's satisfaction to ensure that tightness and condition remain satisfactory. Special attention is to be given to any ballast piping in cargo tanks, and cargo piping in ballast tanks and void spaces, and Surveyors are to be advised on all occasions when this piping, including valves and fittings are open during repair periods and can be examined internally.

Where fitted, the strums of the cargo suction pipes are to be removed or lifted to facilitate examination of the shell plating and bulkheads in the vicinity, unless other means for visual inspection of these parts are provided.

7.7.1.5 The survey extent of ballast tanks converted to void spaces is to be specially considered in relation to the requirements for ballast tanks.

7.7.1.6 For tank protection on oil tankers:

Where provided, the condition of the corrosion prevention system of cargo tanks is to be examined. A Ballast Tank is to be examined at subsequent annual intervals where:

- a) a **hard** protective coating has not been applied from the time of construction; or
- b) a soft or semi-hard coating has been applied; or
- c) substantial corrosion is found within the tank; or
- d) the **hard** protective coating is found to be in less than GOOD condition and the **hard** protective coating is not repaired to the satisfaction of the Surveyor.

Thickness measurements are to be carried out as deemed necessary by the Surveyor.

For areas in tanks where a **hard** protective coatings are found to be in GOOD condition, the thickness measurements may be specially considered.

7.7.1.7 For oil tankers in addition to aforementioned surveys with the ship in a gas free condition the following is to be examined:

- .1 Pump room ventilation system, including ducting, dampers and screens and verification of proper operation is to be carried out.
- .2 Cargo tank vent pipes and headers from tanks including the devices to prevent the passage of flame on vents (to be dismantled and cleaned).
- .3 Cargo tank pressure-vacuum valves to be dismantled and tested for proper operation.
- .4 The sealing arrangements of all penetrations of cargo pump room bulkheads and on deck of cargo tanks.
- .5 Cargo pump room bilge system, and verification of proper operation is to be carried out.
- .6 Proper operation of electrical and mechanical remote operating of cargo, ballast and bilge valves is to be confirmed.
- .7 Safe systems used for measurement, monitoring and control are to be examined and their satisfactory operation is to be verified. It is to be confirmed that flexible hoses for supply of water for washing machines are in good condition. At least ten per cent of washing machines is to be opened out and examined.
- .8 Emergency towing arrangements on tankers for oil and chemical tankers with DWT $\geq 20,000$ are to be thoroughly examined, to ensure ready availability.

7.7.1.8 It is to be confirmed that the crude oil washing system is in accordance with the requirements for such systems and, in particular:

- .1 Pressure testing of the crude oil washing system to at least the working pressure is to be carried out.
- .2 Cargo tanks are to be examined for the express purpose of verifying the continued effectiveness of the installed crude oil washing and stripping systems.
- .3 Isolation valves for any steam heaters are to be examined internally, when fitted.

7.7.1.9 The effectiveness of the crude oil washing system is to be verified by internal tank inspection or by another alternative method acceptable to the *Register*. If the tank cannot be gas-freed for the safe entry of the Surveyor, an internal inspection should not be conducted. An acceptable alternative would be satisfactory results during the surveys required by 4.5.17.

7.7.2 Thickness measurement requirements for oil tankers

7.7.2.1 For oil tankers and combination carriers the minimum requirements for thickness measurements are given in Table 7.7.2-1. For areas with substantial corrosion (according to 1.2.8) extended thickness measurements in accordance with Table 7.7.2-2 sheet 1 to sheet 4 are to be carried out. These extended thickness measurements are to be carried out before the

survey is credited as completed. Suspect Areas identified at previous surveys are to be examined. **Areas of substantial corrosion identified at previous surveys are to have thickness measurements taken.**

7.7.2.2 The Surveyor may further extend the thickness measurements as deemed necessary. For areas in tanks where hard protective coating is found to be in a GOOD condition, the extent of thickness measurements according to Table 7.7.2-1 may be specially considered. Transverse sections are to be chosen where the largest reductions are suspected to occur or are revealed from deck plating measurements. In cases where two or three sections are to be measured, at least one is to include a Ballast Tank within 0.5L amidships.

7.7.2.3 See also 7.5.2.

NOTE: The data and information on the structural condition of the vessel collected during the survey is to be evaluated for acceptability and continued structural integrity of the vessel.

In case of Oil Tankers of 130 m in length and upwards (as defined in the International Convention on Load Lines in force), and more than 10 years of age, the sampling method of thickness measurements is to be used for longitudinal strength evaluation (see 7.7.2.4). The ship's longitudinal strength is to be evaluated by using the thickness of structural members measured, renewed and reinforced as appropriate, in accordance with the criteria for longitudinal strength of the ship's hull girder for oil tankers specified in the *Rules for the classification of ships, Part 2 – Hull*, Annex B. The analysis of data should be carried out and endorsed by the Register and the conclusions of the analysis should form a part of the Executive Hull Summary.

The final result of evaluation of the ship's longitudinal strength after renewal or reinforcement work of structural members, if carried out as a result of initial evaluation, should be reported as a part of the Executive Hull Summary.

7.7.2.4 Sampling method of thickness measurements for longitudinal strength evaluation and repair methods:

- .1 Extent of longitudinal strength evaluation - Longitudinal strength should be evaluated within 0.4L amidships for the extent of the hull girder length that contains tanks therein and within 0.5L amidships for adjacent tanks which may extend beyond 0.4L amidships, where tanks means ballast tanks and cargo tanks.
- .2 Sampling method of thickness measurement:
 - a) Pursuant to the requirements of 7.7.2, transverse sections should be chosen such that thickness measurements can be taken for as many different tanks in corrosive environments as possible, e.g. ballast tanks sharing a common plane boundary with cargo tanks fitted with heating coils, other ballast tanks, cargo tanks permitted to be filled with sea water and other cargo tanks. Ballast tanks sharing a common plane boundary with cargo tanks fitted with heating coils and cargo tanks permitted to be filled with sea water should be selected where present,
 - b) The minimum number of transverse sections to be sampled should be in accordance with Table 7.7.2-1. The transverse sections should be located

where the largest thickness reductions are suspected to occur or are revealed from deck and bottom plating measurements prescribed in c) below and should be clear of areas which have been locally renewed or reinforced,

- c) At least two points should be measured on each deck plate and/or bottom shell plate required to be measured within the cargo area in accordance with the requirements of Table 7.7.2-1,
 - d) Within 0.1D (where D is the ship's moulded depth) of the deck and bottom at each transverse section to be measured in accordance with the requirements of Table 7.7.2-1, every longitudinal and girder should be measured on the web and face plate, and every plate should be measured at one point between longitudinals,
 - e) For longitudinal members other than those specified in d) above, to be measured at each transverse section in accordance with the requirements of Table 7.7.2-1, every longitudinal and girder should be measured on the web and face plate, and every plate should be measured at least in one point per strake,
 - f) The thickness of each component should be determined by averaging all of the measurements taken in way of the transverse section on each component.
- .3 Additional measurements where the longitudinal strength is deficient:
- a) Where one or more of the transverse sections are found to be deficient in respect of the longitudinal strength requirements given in this annex, the number of transverse sections for thickness measurement should be increased such that each tank within the 0.5L amidships region has been sampled. Tank spaces that are partially within, but extend beyond, the 0.5L region, should be sampled,
 - b) Additional thickness measurements should also be performed on one transverse section forward and one aft of each repaired area to the extent necessary to ensure that the areas bordering the repaired section also comply with the requirements of 7.7.2,
- .4 Effective repair methods:
- a) The extent of renewal or reinforcement carried out to comply with this annex should be in accordance with b) below,
 - b) The minimum continuous length of a renewed or reinforced structural member should be not less than twice the spacing of the primary members in way. In addition, the thickness diminution in way of the butt joint of each

joining member forward and aft of the replaced member (plates, stiffeners, girder webs and flanges, etc.) should not be within the substantial corrosion range (75% of the allowable diminution associated with each particular member). Where differences in thickness at the butt joint exceed 15% of the lower thickness, a transition taper should be provided,

- c) Alternative repair methods involving the fitting of straps or structural member modification should be subject to special consideration. In considering the fitting of straps, it should be limited to the following conditions:
- to restore and/or increase longitudinal strength;
 - the thickness diminution of the deck or bottom plating to be reinforced should not be within the substantial corrosion range (75% of the allowable diminution associated with the deck plating);
 - the alignment and arrangement, including the termination of the straps, is in accordance with a standard recognized by the *Register*;
 - the straps are continuous over the entire 0.5L amidships length; and
 - continuous fillet welding and full penetration welds are used at butt welding and, depending on the width of the strap, slot welds. The welding procedures applied should be acceptable to the *Register*.
- d) The existing structure adjacent to replacement areas and in conjunction with the fitted straps, etc. should be capable of withstanding the applied loads, taking into account the buckling resistance and the condition of welds between the longitudinal members and hull envelope plating.

7.7.3 Void

7.7.4 Close-up survey requirements for oil tankers

7.7.4.1 An Overall survey of all tanks and spaces, is to be carried out at each Renewal survey, as determined in Table 7.2.1-2.

7.7.4.2 Each Renewal survey is to include a Close-up examination of sufficient extent to establish the condition of the shell frames and their end attachments in all cargo holds and ballast tanks. Close-up survey is to be performed in accordance with the requirements stated in Table 7.7.4-1, for oil tankers and ore/oil ships.

The Surveyor may extend the Close-up Survey as deemed necessary taking into account the maintenance of the tanks under survey, the condition of the corrosion prevention system and also in the following cases:

- a) In particular, tanks having structural arrangements or details which have suffered defects in similar tanks or on similar ships according to available information.
- b) In tanks which have structures approved with reduced scantlings due to an approved corrosion control system.

For areas in tanks or spaces where hard protective coatings are found to be in GOOD condition, the extent of Close-up may be specially considered.

7.7.5 Tank testing requirements for oil tankers

7.7.5.1 Ballast tank testing is to be carried out by means of hydrostatic pressure test according to Tables 7.2.1-2 and 7.7.5-1, for oil tankers and combination carriers.

The minimum requirements for cargo tank testing at Renewal Survey are given in 7.7.5.2 and Table 7.7.5-1.

7.7.5.2 Cargo tank testing carried out by the ship's crew under the direction of the Master may be accepted by the surveyor provided the following conditions are complied with:

- a) a tank testing procedure, specifying fill heights, tanks being filled and bulkheads being tested, has been submitted by the owner and reviewed by the *Register* prior to the testing being carried out;
- b) the tank testing is carried out prior to overall survey or close-up survey;
- c) the tank testing is carried out within the renewal survey window and not more than 3 months prior to the date on which the overall or close up survey is completed;
- d) the tank testing has been satisfactorily carried out and there is no record of leakage, distortion or substantial corrosion that would affect the structural integrity of the tank;
- e) the satisfactory results of the testing is recorded in the vessel's logbook; and
- f) the internal and external condition of the tanks and associated structure are found satisfactory by the surveyor at the time of the overall and close up survey.

7.7.5.3 The Surveyor may extend the tank testing if deemed necessary.

7.8 ADDITIONAL RENEWAL SURVEY REQUIREMENTS FOR CHEMICAL TANKERS

7.8.1 The requirements of Annex A as well as of 5.7, 6, 7.2, 7.4, 7.5 and 7.6 are to be complied with as applicable.

7.9 ADDITIONAL RENEWAL SURVEY REQUIREMENTS FOR SHIPS WITH INERT GAS SYSTEM FITTED

7.9.1 The requirements of 4.8 are to be complied with.

7.9.2 At each Renewal survey of the inert gas system the following items are to be opened out as considered necessary and examined:

- .1 The inert gas generator (if fitted).
- .2 The scrubber.
- .3 The deck water seal and non-return valve.
- .4 All valves, including overboard discharge valve of the scrubber.
- .5 The inert gas blowers.

7.9.3 On completion of survey the complete installation is to be tested under working conditions including testing of all automatic shutdown devices and alarms.

7.9.4 If any examination during survey reveals defects, further parts are to be opened up and examined as considered necessary by the Surveyor, and the defects are to be made good to his satisfaction.

7.10 RENEWAL SURVEY REQUIREMENTS FOR FLOATING UNITS

7.10.1 Following requirements apply to type notations **floating dock**, **floating storage**, and **floating restaurant**. The requirements of 4.9 and 6 are to be complied with so far as applicable.

7.10.2 Renewal surveys of hull, equipment and auxiliaries of floating units are to be held every five years (for floating docks see 7.10.4).

7.10.3 In addition to the aforementioned for all floating units the following are to be dealt with so far as applicable:

- .1 Survey of hull and hull equipment is to be carried out in accordance with requirements of 7.2.
- .2 Survey of machinery is to be carried out in accordance with requirements of 8.
- .3 Survey of electrical equipment is to be carried out in accordance with requirements of 11.
- .4 Survey of automation systems is to be carried out in accordance with requirements of 9.
- .5 Survey of fire protection arrangements is to be carried out in accordance with requirements of 7.4.

7.10.4 While performing Renewal survey of **floating docks** in addition to aforementioned requirements the following is to be complied with as applicable:

- .1 Renewal surveys for steel and wooden floating docks (irrespective if metal sheathed or not), are to be held every five years and for floating docks built of reinforced concrete (ferro-cement) every ten years.

- .2 The dock structure is to be immersed as little as possible.
- .3 The structural elements above the waterline are to be inspected both, internally and externally, and the watertight compartments internally only, as far as deemed necessary by the Surveyor.
- .4 Piping arranged inside watertight compartments including their valves (inlet and outlet) is to be examined and checked for tightness and operability.
- .5 The boundary bulkheads of the watertight compartments are to be surveyed for excessive corrosion, deformation, fractures damages and other structural deterioration. The compartments are to be air tested with maximum pressure of 0.2 [bar] (0.02 [MPa]) to ascertain the tightness. At least every other compartment is to be tested and the tightness of the whole safety deck is to be tested. The Surveyor may extend the testing if deemed necessary.
- .6 Thickness measurements at parts of the dock structure are to be carried out in accordance with requirements given in Table 7.2.1-3 so far as applicable.
- .7 Dry-docking or bottom survey with the dock in inclined position is to be restricted to special cases (averages, leakages', etc.) upon agreement between the Company and the *Register*.
- .8 An in-water survey may be conducted in lieu of a dry-docking survey, as long as the condition of the underwater part of the structure, and anchoring and mooring system is found acceptable and without reported damages during the last period.

7.11 RENEWAL SURVEY REQUIREMENTS FOR TECHNICAL FLOATING UNITS

7.11.1 Following requirements apply to type notations **split hopper barge**, **dredger**, and **self-unloading hopper barge**. The requirements of 4.10, 4.15, 6 and 7.10.3 are to be complied with so far as applicable.

7.11.2 Where surveys are required on dredging or hopper equipment such as gantries, bottom doors and their opening gear, positioning spuds and suction pipe attachments or split hull devices such as actuating and locking devices, these will be limited to the extent considered necessary by the Surveyor to satisfy himself that their condition or malfunction will not adversely affect the ship's structure.

7.11.3 For technical floating units up to 10 (ten) years old in addition to requirements of 7.11.1 and 7.11.2 the following is to be complied with:

- .1 Hoppers are to be cleared and cleaned as necessary and examined.
- .2 The integrity of hopper overflows and diluting water inlet and distribution structures is to be confirmed.

- .3 Weir valves and sluices are to be tested to ensure proper operation, particular attention being paid to the lower weir, when weirs are fitted at more than one level.
- .4 Shell plating in way of hopper overflows is to be carefully examined.
- .5 The attachment to the ship's structure of all main items of dredging equipment, including gantries, "A" frames, spud control gear supports and items provided to facilitate separation of split hulls including hinge pin gudgeons, anchorages for rams and locking devices, is to be carefully examined to ensure that no fracture is present.
- .6 for **self-unloading hopper barge**, visual examination of hopper bottom doors or valves and accessories, such as hinges, actuating rods, hydraulic systems, with dismantling as deemed necessary by the Surveyor,
- .7 for **split hopper barge** (split hopper unit), visual examination, as far as practicable, of superstructure hinges and blocks, deck hinges, hydraulic jacks and associated piping systems and alarms, with dismantling and/or further checks as deemed necessary by the Surveyor,
- .8 for **dredger, self-unloading hopper barge, split hopper barge**:
 - a) visual examination, as far as practicable, of attachments of suction piping and lifting systems to the structure and external examination of piping in dredging machinery spaces for absence of corrosion and leakage,
 - b) checking the condition of the dredging machinery space and related equipment with regard to electrical shocks, protection from rotating machinery, fire and explosion hazards.

7.11.4 For technical floating units over ten (10) years of age in addition to requirements of 7.11.3 the following is to be complied with:

- .1 Structure in way of dredging pumps is to be carefully examined.
- .2 Hopper doors, valves and items provided to facilitate separation of split hulls are to be checked for proper operation, and their hinges, control gear and other fittings are to be examined for wear or distortion.
- .3 All seals and wear-down strips are to be replaced if necessary, but a watertight seal is not normally required.
- .4 Areas likely to be suffering from excessive erosion are to be carefully examined.
- .5 Those items of dredging gear and equipment whose efficiency is not part of survey, but whose failure or malfunctioning is, nevertheless, likely to adversely affect the ship's structure, are to be examined to ensure that the structural integrity of the ship is maintained.

7.11.5 For units with type notation **Barge-solid bulk cargo in cargo holds** and **Barge-cargo on weather deck** the weathertightness of hatch covers are to be checked by hose testing. Shell and deck plating is to be examined.

7.11.6 The following requirements apply to floating units, other than units with type notation **Floating dock**, **Floating storage unit** or **Floating restaurant**, subject to classification by the *Register*, engaged in port areas or other enclosed areas and permanently moored, anchored or based on seabed:

- .1 The requirements of Section 6 of this Chapter of the Rules are to be complied with, as far as applicable.
- .2 For floating units consisting of separate but mutually connected pontoons, the condition of connectors/connecting system is to be verified.
- .3 Condition of anchoring, mooring blocks and mooring system is to be verified.
- .4 For floating units with anchor piling system, condition of piling and pile guide roller is to be verified.
- .5 An in-water survey may be conducted in lieu of a dry-docking survey, as long as the condition of the underwater part of the structure, and anchoring and mooring system is found acceptable and without reported damages during the last period.

7.12 ADDITIONAL RENEWAL SURVEY REQUIREMENTS FOR GENERAL DRY CARGO SHIPS

7.12.1 General requirements for hull and hull equipment surveys

7.12.1.1 A survey planning meeting is to be held prior to commencement of the survey. As part of the preparation for renewal survey the thickness measurement is to be dealt with, in advance of the survey. The survey in accordance with the requirements stated in 4.11, 7.2 and 7.4 is to be carried out as far as practicable.

7.12.1.2 A survey in dry dock is to be part of the renewal survey.

7.12.1.3 All cargo holds, ballast tanks including double bottom tanks, pipe tunnels, cofferdams and void spaces bounding cargo holds, decks and outer hull are to be examined, and this examination is to be supplemented by thickness measurement and testing (see 7.12.2 and 7.12.4), to ensure that the structural integrity remains effective.

The aim of the examination is to discover Substantial corrosion, significant deformation, fractures, damages, or other structural deterioration, that may be present.

7.12.1.4 All piping systems within the above spaces are to be examined and tested to working pressure to ensure that the condition remains satisfactory.

7.12.1.5 The survey extent of ballast tanks converted to void spaces is to be specially considered in relation to the requirements for ballast tanks.

NOTE: For survey of automatic air pipes see Table 7.2.1-4.

7.12.1.6 Where provided, the condition of the corrosion prevention system of ballast tanks is to be examined. For ballast tanks, excluding double bottom tanks, where a hard protective coating (see 1.2.9) is found in POOR condition and it is not renewed or where soft or semi-hard coating has been applied, or where a hard protective coating has not been applied from the time of construction, the tanks in question are to be examined at annual intervals. Thickness measurements are to be carried out as deemed necessary by the Surveyor.

When such breakdown of coating is found in double bottom ballast tanks and it is not renewed, where a soft or semi-hard coating has been applied, or where a hard protective coating was not applied from the time of construction, the tanks in question may be examined at annual intervals. When considered necessary by the Surveyor, or when extensive corrosion exists, thickness measurements are to be carried out.

Where a **hard** protective coating in tanks is found to be in GOOD condition, the extent of Close-up surveys and thickness measurements may be specially considered.

7.12.2 Thickness measurement requirements for general dry cargo ships

7.12.2.1 The minimum requirements for thickness measurements at renewal survey are given in Table 7.12.2-1. The requirements of 7.5 are also to be complied with.

7.12.2.2 The Surveyor may extend the thickness measurements as deemed necessary. When thickness measurements indicate substantial corrosion, the number of thickness measurements are to be increased to determine the extent of substantial corrosion. Table 7.2.1-3a may be used as guidance for these additional thickness measurements.

7.12.2.3 For areas in spaces where hard protective coatings are found to be in a GOOD condition, the extent of thickness measurement according to Table 7.12.2-1. may be specially considered.

7.12.2.4 Transverse sections are to be chosen where the largest reductions are suspected to occur or are revealed from deck plating measurements.

7.12.3 Overall and close-up survey requirements for general dry cargo ships

7.12.3.1 An Overall survey of all tanks and spaces, excluding fuel oil, lube oil and freshwater tanks, is to be carried out at each Renewal survey.

NOTE: For fuel oil, lube oil and freshwater tanks, see Table 7.2.1-2.

7.12.3.2 The minimum requirements for close-up surveys at Renewal survey are given in Table 7.12.3-1.

The Surveyor may extend the close-up survey as deemed necessary taking into account the maintenance of the spaces under survey, the condition of the corrosion prevention system and where spaces have structural arrangements or details which have suffered defects in similar spaces or on similar ships according to available information.

For areas in spaces where hard protective coatings are found to be in a GOOD condition, the extent of close-up

surveys according to Table 7.12.3-1 may be specially considered.

NOTE: For survey of automatic air pipes see Table 7.2.1-4

7.12.4 Tank Testing requirements for general dry cargo ships

7.12.4.1 All boundaries of ballast tanks and deep tanks used for ballast within the cargo area length are to be pressure tested. For fuel oil tanks, only the representative tanks are to be pressure tested.

7.12.4.2 The Surveyor may extend the tank testing as deemed necessary.

7.12.4.3 Tank testing of fuel oil tanks is to be carried out with a head of liquid to the highest point that liquid will rise under service conditions. Tank testing of fuel oil tanks may be specially considered based on a satisfactory external examination of the tank boundaries, and a confirmation from the Master stating that the pressure testing has been carried out according to the requirements with satisfactory results.

7.12.5 Additional renewal survey requirements after determining compliance with SOLAS 74, Ch. II-I/25, for general cargo ships with single hold

7.12.5.1 For ships less than 80 meters in length, or for ships built before 1st July 1998 less than 100 meters in length, with single hold not protected by double hull, requirements of 7.7.3.1 apply.

7.13 ADDITIONAL RENEWAL SURVEY REQUIREMENTS FOR LIVE-STOCK CARRIERS

7.13.1 The survey in accordance with the requirements stated in 4.12, 7.2 and 7.4 is to be carried out as far as practicable.

7.13.2 The equipment related to ventilation, lighting and the related power supply is to be submitted to a survey to the same extent as required for similar equipment as indicated in 4.4.2. and 11.2.

7.13.3 The drainage, fodder, and freshwater systems, including piping and pumps, are to be surveyed to the same extent as required for similar equipment at the class renewal survey as indicated in 8.3.1 8.7.1 and 8.7.8.

The freshwater tanks are to be internally examined in accordance with the periodicity given in Table 7.2.1-2.

7.13.4 The fire-fighting systems are to be thoroughly examined and tested.

7.14 ADDITIONAL RENEWAL SURVEY REQUIREMENTS FOR FAST VESSELS

7.14.1 High speed craft

Inspection of the structure, machinery safety equipment radio installations any stabilisation systems, air

cushion systems and other equipment is to be carried out as far as applicable, to ensure that they are in satisfactory condition and are fit for the service for which the craft is intended for the next five year period and, that no unapproved changes have been made to structure, equipment, fittings, arrangements and materials covered by the survey. The survey includes as far as applicable the following:

- .1 inspection of the outside of the craft bottom and thickness measurement on steel craft (for other craft if Surveyor deems it necessary) in accordance with Section 6 and Table 7.2.1-3, with particular attention given to hull appendages (hydrofoils, hydrofoil supports, skirt fixations, shaft brackets, etc.) and to their fixation to the hull and, to the condition of the corrosion protection system of the structure,
- .2 inspection of the propeller shafts and propellers in accordance with Section 10,
- .3 inspection of the hull and machinery in accordance with 7.2, 7.4 and Section 8 and inspection of automation systems in accordance with section 9.

7.14.2 Dynamically supported craft and Fast craft

Every fifth year the survey in accordance with 7.14.1 is to be carried out as far as applicable.

7.15 ADDITIONAL RENEWAL SURVEY REQUIREMENTS FOR RO-RO CARGO SHIPS, PASSENGER SHIPS, RO-RO PASSENGER SHIPS

Following requirements apply to type notations **Ro-ro cargo ship, Passenger ship, Ro-ro passenger ships**. The survey in accordance with the requirements stated in 4.14, 7.2 and 7.4 is to be carried out as far as practicable.

7.15.1 Ro-Ro cargo ships

7.15.1.1 Shell and inner doors

- .1 A close visual inspection of structural arrangements is to be carried out, supplemented by non-destructive tests and/or thickness measurements, as deemed necessary by the Surveyor.
- .2 The close visual inspection of securing, supporting and locking devices, as required for the annual survey, is to be supplemented by non-destructive tests and/or thickness measurements.
- .3 Clearances of hinges, bearings and thrust bearings are to be measured. Dismantling may be required as deemed necessary by the Surveyor.
- .4 Non-return valves of drainage arrangements are to be checked after dismantling.

7.15.1.2 Internal platforms and ramps

- .1 The condition of pulleys, axles, cables and structure of the platforms and ramps is to be checked,

Electric motors and/or hydraulically operated equipment are to be surveyed for the class renewal survey of machinery installations.

7.15.1.3 Fire protection, detection and extinction

- .1 Within the scope of survey of fire protection, detection and extinction arrangements as required for the annual survey of all ships in 4.4.2 attention is to be given to the particular arrangements related to Ro-Ro cargo spaces, such as those indicated in 4.14.1.3.

7.15.2 Passenger ships

The following shall apply:

- .1 A lightweight survey is to be carried out to verify any changes in lightship displacement and in the longitudinal position of the centre of gravity. Where, in comparison with the approved stability information, a deviation exceeding 2% in the lightship displacement or a deviation of the longitudinal centre of gravity exceeding 1% of the length between perpendiculars is found or anticipated, the ship is to be submitted to a new inclining test.
- .2 The condition of the Low Location Lighting (LLL) system, where fitted, and its power source(s) is to be verified.

NOTE: The *Register* does not require lightweight survey for ships not engaged on international voyages, as in such cases specific requirements of the Flag State Administration shall apply.

7.15.3 Ro-Ro passenger ships

- .1 The scope of the annual survey and class renewal survey of Ro-Ro passenger ship is to include the scope of surveys required for the service notations Ro-Ro cargo ship and passenger ships, as detailed in 4.14.3, 7.2.3 and 7.15.2.
- .2 In addition to .1, the condition of means of escape as well as of fire protection, detection and extinction in special category spaces is to be checked.

7.16 ADDITIONAL RENEWAL SURVEY REQUIREMENTS FOR TUGS AND SUPPLY VESSELS

Following requirements apply to type notations **tug and supply vessel**. The survey in accordance with the requirements stated in 4.16, 7.2 and 7.4 is to be carried out as far as practicable.

7.16.1 The survey is to include:

- .1 checking the condition of the connection of the towing hook or towing winch to the structure, including related reinforcements of the structure.
- .2 checking the external condition of the towing hook or towing winch; when applica-

ble, a no-load test of the unhooking device is to be carried out.

- .3 for vessels with additional class notation FIR or FIR F, operational testing of the fixed self-protection water-spraying system, the water fire extinguishing systems and/or foam fire-extinguishing systems.

7.17 ADDITIONAL RENEWAL SURVEY REQUIREMENTS FOR FISHING VESSELS

The survey in accordance with the requirements stated in 4.16, 7.2 and 7.4 is to be carried out as far as practicable.

7.17.1 For fishing vessels 10 years age and over, the class renewal survey is to include thickness measurements of structural elements prone to rapid wastage, such as the stern ramp, weather deck in way of the working area of the nets, connections to hull structure of masts, gantries, winches and traw gallows (for side trawlers).

7.18 ADDITIONAL RENEWAL SURVEY REQUIREMENTS FOR ASPHALT CARRIERS

7.18.1 In the case of double hull asphalt carriers, intended for the carriage of cargo in integral tanks, hull Renewal survey requirements for double-hull oil tankers should apply (*Rules for the classification of ships, Part 1 – General requirements, Chapter 5 – Surveys of ships in service, Annex B*).

In the case of single hull asphalt carrier intended for the carriage of cargo in integral tanks, requirements for hull Renewal survey requirements for single hull tankers, as stated in 7.7 should apply.

In the case of asphalt carriers intended for the carriage of cargo in independent tanks requirements for the

hull Renewal survey applicable for all ships, as stated in 7.2 should apply.

7.18.2 These survey requirements are considered to be additional to those applicable to Intermediate survey, 5.6.

7.18.3 In addition to the requirements stated in 7.18.1 (and 7.18.2) the following items are to be surveyed also, as being specific for asphalt carriers.

7.18.3.1 Piping for cargo, ballast, stripping, and venting systems is to be examined.

Dismantling and/or thickness measurements of these items may be required. A pressure test is to be carried out in the event of repair or dismantling of cargo or ballast piping, or where doubts arise.

7.18.3.2 All safety valves on cargo piping and pressure / vacuum valves of cargo tanks are to be dismantled for examination, adjusted and, as applicable, resealed.

7.18.3.3 All cargo pump room boundaries are to be generally examined. All gas-tight shaft sealing devices are to be examined. The bottom of cargo pump rooms is to be presented clean for the examination of stripping devices and gutters.

7.18.3.4 The survey of independent cargo tanks is to include the internal examination and external examination of the structure surrounding the independent cargo tanks for damage, cracks or deterioration, including the thermal isolating material and elements supporting and/or securing the cargo tanks.

7.18.3.5 Ballast, cargo (if maintenance records of cargo pumps not being available) and stripping pumps are to be internally examined and prime movers checked. A working test is to be carried out.

Maintenance records of cargo pumps are to be presented to the Surveyor.

7.18.3.6 Satisfactory condition of the cargo heating system such as clamping and piping is to be verified and, if deemed necessary, the system is to be pressure tested.

Table 7.2.1-1
Preparation for survey

I Renewal survey (age ≤ 5)	II Renewal survey (5 < age ≤ 10)	III Renewal survey and all subsequent surveys (age > 10)
<ol style="list-style-type: none"> 1. In machinery spaces as well as in the pump rooms platform plates are to be lifted as may be necessary for the examination of the structure, bilge suction, piping and fittings below such plates. Special consideration is to be given to the condition of the structure adjacent to the boilers as well to the condition of the double bottom tanks below such boilers. 2. In ships having a single bottom in every watertight compartment a sufficient amount of close ceiling is to be lifted all fore and aft on each side from the bottom and bilges to permit the structure, bilge suction, piping and fittings below to be examined. 3. In ships having a double bottom, a sufficient amount of ceiling is to be removed from the bilges and inner bottom to enable the condition of the plating to be ascertained. 4. Where holds are insulated for the purpose of carrying refrigerated cargoes a sufficient amount of limbers and hatches is to be removed to enable the framing and plating in way to be examined. 	<ol style="list-style-type: none"> 1. The requirements for the I Renewal survey are to be fulfilled. 2. A sufficient amount of ceiling in the holds and other spaces is to be removed from the bilges and inner bottom to enable the condition of the structure in the bilges, the inner bottom plating, pillar feet, and the bottom plating of bulkheads and tunnel sides to be examined. If the Surveyor deems it necessary, the whole of the ceiling is to be removed. 3. Wood decks or sheathing are to be examined. If decay or rot is found or the wood is excessively worn, the wood is to be renewed. Attention is to be given to the condition of the plating under wood decks, sheathing or other deck covering. 4. The chain locker is to be cleaned internally before the survey commences. Wood sheathing from the chain locker is to be removed in order to enable the structure below to be examined. 	<ol style="list-style-type: none"> 1. The requirements for the II Renewal survey are to be fulfilled. 2. Ceiling in holds is to be removed in order to ascertain that the steelwork is in good condition, free from rust and coated. If the Surveyor is satisfied, after removal of portions of ceiling then it need not be removed completely. 3. Portions of wood sheathing, or other covering, on steel decks are to be removed, as considered necessary by the Surveyor, in order to ascertain the condition of the plating. 4. Casings or covers of air, sounding, steam and other pipes, spar ceiling and lining in way of side scuttles are to be removed, as required by the Surveyor.
<p>NOTES: In cases where the inner surface of the bottom plating is covered with cement, asphalt, or other composition, the removal of this covering may be dispensed with, provided that it is inspected, tested by beating or chipping, and found sound and adhering satisfactorily to the steel.</p>		

Table 7.2.1-2

Tank internal examination and testing requirements - all ships
 For additional requirements for tank testing on oil tankers see Table 7.7.5-1
 For additional internal examination requirements for chemical tankers see 2.2.1.2 of Annex A

Tank ^{1),2),3)}	I Renewal survey (age ≤ 5)	II Renewal survey (5 < age ≤ 10)	III Renewal survey (10 < age ≤ 15)	IV Renewal survey and all subsequent surveys (age > 15)
<i>Ballast tanks</i>	All	All	All	All
<i>Fuel Oil bunker tanks:</i> - <i>Engine room</i> - <i>Cargo Length area</i> - <i>If no tanks in Cargo Length Area, addi- tional fuel tank(s) outside of Engine Room (if fitted)</i>	None None None	None One One	One Two One	One Half, minimum 2 Two
<i>Lubricating oil</i>	None	None	None	One
<i>Fresh water</i>	None	One	All	All

NOTES:

- 1) These requirements apply to tanks of integral (structural) type.
- 2) If a selection of tanks is accepted to be examined, then different tanks are to be examined at each renewal survey, on a rotational basis.
- 3) Peak tanks (all uses) are subject to internal examination at each renewal survey.
- 4) At Renewal surveys no 3 and subsequent surveys, one deep tank for fuel oil in the cargo length area is to be included, if fitted.
- 5) Boundaries of double-bottom, deep, ballast, peak, and other tanks, including holds adapted for the carriage of ballast, are to be tested with a head of liquid to the top of air pipes or to near the top of hatches for ballast/cargo holds. Boundaries of fuel oil, lube oil, and fresh water tanks are to be tested with a head of liquid to the highest point that liquid will rise under service conditions. Tank testing of fuel oil, lube oil and fresh water tanks may be specially considered based on satisfactory external examination of the tank boundaries, and a confirmation from the Master stating that the pressure testing has been carried out according to the requirements with satisfactory results. The Surveyor may extend the testing as deemed necessary.

Table 7.2.1-3

Minimum requirements for thickness measurement - all ships

For additional requirements for oil tankers with affixed **ESP** notation see Table 7.7.2-1 or Table II, Annex B, for chemical tankers see Table II, Annex A, for bulk carriers see Table II, Annex C1, and for general dry cargo ships see Table 7.12.2.1

I Renewal survey (age ≤ 5)	II Renewal survey (5 < age ≤ 10)	III Renewal survey (10 < age ≤ 15)	IV Renewal survey and all subsequent surveys (age > 15)
1. Suspect areas, throughout the ship.	1. Suspect areas, throughout the ship. 2. One transverse section of deck plating within the amidships 0,5L (in way of a cargo space, if applicable).	1. Suspect areas, throughout the ship. 2. Two transverse sections within the amidships 0.5L (in way of two cargo spaces, if applicable). 3. All cargo hatch covers and coamings (plating and stiffeners). 4. Internals in forepeak and afterpeak ballast tanks.	1. Suspect areas, throughout the ship. 2. A minimum of three transverse sections within the amidships 0,5L (in way of cargo spaces, if applicable). 3. All cargo hatch covers and coamings (plating and stiffeners). 4. Internals in forepeak and afterpeak ballast tanks. 5. All exposed main deck plating full length. 6. Representative exposed superstructure deck plating (poop, bridge, and fore-castle deck). 7. Lower strake and strakes in way of 'tween decks of all transverse bulkheads in cargo spaces together with internals in way. 8. All wind and water strakes, port and starboard, full length. 9. All keel plates full length. Also, additional bottom plates in way of cofferdams, machinery space and aft end of tanks. 10. Plating of seachests. Shell plating in way of overboard discharges as considered necessary by the attending Surveyor.

NOTES:

For thickness measurements reporting, the standard forms as proposed by IACS may be used, as appropriate. The forms are a recommendation and are not a mandatory requirement.

- 1) Thickness measurement locations should be selected to provide the best representative sampling of areas likely to be most exposed to corrosion, considering cargo and ballast history and arrangement and condition of protective coatings.
- 2) Thickness measurements of internals may be specially considered by the Surveyor if the hard protective coating is in GOOD condition.
- 3) For ships less than 100 meters in length, the number of transverse sections required at Renewal survey No. III may be reduced to one, and the number of transverse sections required at subsequent Renewal surveys may be reduced to two.
- 4) For ships more than 100 meters in length, at Renewal survey No. III, thickness measurements of exposed deck plating within amidship 0,5L may be required.
- 5) Subject to cargo hold hatch covers of approved design which structurally have no access to the internals, thickness measurement shall be done of accessible parts of hatch covers structures.
- 6) Thickness measurements are to be taken on transverse sections where biggest wastage is expected.

Table 7.2.1-3a

Minimum requirements to thickness measurements in way of substantial corrosion - all types of ships except oil tankers, chemical tankers, ore/bulk/oil ships, ore/oil ships and bulk carriers

Structural member	Extent of measurement	Pattern of measurement
<i>Plating</i>	Suspect area and adjacent plates.	5-point pattern over one square meter.
<i>Stiffeners</i>	Suspect area.	3 measurements each in line across web and flange.

Table 7.2.1-4

Survey requirements for automatic air pipe heads

I Renewal survey (age ≤ 5)	II Renewal survey (5 < age ≤ 10)	III Renewal survey and all subsequent surveys (age > 10)
<ol style="list-style-type: none"> Two (see NOTES) air pipe heads, one port and one starboard, located on the exposed decks in the forward 0.25 L, preferably air pipes serving ballast tanks. Two (see NOTES) air pipe heads, one port and one starboard, on the exposed decks, serving spaces aft of 0.25 L, preferably air pipes serving ballast tanks. <p>1) 2)</p>	<ol style="list-style-type: none"> All air pipe heads located on the exposed decks in the forward 0.25 L At least 20% (see NOTES) of air pipe heads, on the exposed decks serving spaces aft of 0.25 L, preferably air pipes serving ballast tanks. <p>1) 2)</p>	<p>All air pipe heads located on the exposed decks. Exemption may be considered for air pipe heads where there is substantiated evidence of replacement within the previous five years.</p> <p>3)</p>
<p>NOTES:</p> <ol style="list-style-type: none"> The selection of air pipe heads to be inspected is left to the attending Surveyor. According to the results of this inspection, the Surveyor may require the inspection of other air pipe heads located on the exposed decks. Exemption may be considered for air pipe heads where there is substantial evidence of replacement after the last renewal survey. 		

Table 7.7.2-1
Minimum additional requirements to thickness measurement - Oil tankers with affixed **ESP** notation

I Renewal survey (age ≤ 5)	II Renewal survey (5 < age ≤ 10)	III Renewal survey (10 < age ≤ 15)	IV Renewal survey and all subsequent surveys (age > 15)
1. Suspect areas. 2. One section of deck plating for the full beam of the ship within the cargo area (in a way of a ballast tank, if any, or a cargo tank used primarily for the water ballast). 4. Measurements, for general assessment and recording of corrosion pattern of those structural members subject to Close-up survey according to Table 7.7.4-1.	1. Suspect areas. 2. Within the cargo area: a) each deck plate, b) one transverse section. 3. Selected wind and water strakes outside the cargo area. 4. Measurements, for general assessment and recording of corrosion pattern of those structural members subject to Close-up survey according to Table 7.7.4-1.	1. Suspect areas. 2. Within the cargo area: a) each deck plate, b) two transverse sections. c) all wind and water strakes. 3. Selected wind and water strakes outside the cargo area. 4. Measurements, for general assessment and recording of corrosion pattern of those structural members subject to Close-up survey according to Table 7.7.4-1.	1. Suspect areas. 2. Within the cargo area: a) each deck plate, b) three transverse sections, c) each bottom plate 3. All wind and water strakes, full length. 4. Measurements, for general assessment and recording of corrosion pattern of those structural members subject to Close-up survey according to Table 7.7.4-1.
NOTES: 1) Where two or three transverse sections are required to be measured, at least one is to include a ballast tank within 0.5L amidships. 2) Transverse sections are to be chosen where the largest reductions are likely to occur, or as revealed by deck plating measurement.			

Table 7.7.2-2 sheet 1

Requirements for extent of thickness measurement at those areas of Substantial Corrosion - Oil tankers with affixed **ESP** notation

BOTTOM STRUCTURE		
Structural member	Extent of measurement	Pattern of measurement
<i>Bottom plating</i>	Minimum of three bays * across tank, including aft bay. Measurement around and under all bell mouths.	5-point pattern for each panel ** between longitudinals and webs.
<i>Bottom longitudinals</i>	Minimum of 3 longitudinals in each bay where bottom plating measured.	3 measurement in line across flange and 3 measurement on vertically web.
<i>Bottom girders and brackets</i>	At fore and aft transverse bulkhead, bracket toes and in centre of tanks.	Vertical line of single measurements on web plating with 1 measurement between each panel stiffener, or a minimum of 3 measurements. 2 measurements across face flat. 5-point pattern on girder / bulkhead brackets.
<i>Bottom transverse webs</i>	3 webs in bays where bottom plating measured, with measurements at both ends and middle.	5-point pattern over 2 square metre area. Single measurements on face flat.
<i>Panel stiffening</i>	Where provided.	Single measurements.
NOTES: * Bay is an area between two bottom transverses, or between a bottom transverse and a transverse bulkhead. ** Panel denotes area between two longitudinals limited by transverses or by bulkheads		

Table 7.7.2-2 sheet 2

Requirements for extent of thickness measurement at those areas of Substantial Corrosion - Oil tankers with affixed **ESP** notation – within the cargo tank length

DECK STRUCTURE		
Structural member	Extent of measurement	Pattern of measurement
<i>Deck plating</i>	Two bands across tank.	Minimum of three measurements per plate per band.
<i>Deck longitudinals</i>	Minimum of 3 longitudinals in each of two bays.	3 measurements in line vertically on webs and 2 measurements on flange (if fitted).
<i>Deck girders and brackets</i>	At fore and aft transverse bulkhead, bracket toes and in centre of tanks.	Vertical line of single measurements on web plating with 1 measurement between each panel stiffener, or a minimum of 3 measurements. 2 measurements across face flat. 5-point pattern on girder / bulkhead brackets.
<i>Deck transverse webs</i>	Minimum of 2 webs with measurement at middle and both ends of span.	5-point pattern over about 2 square metre areas. Single measurements on face flat.
<i>Panel stiffening</i>	Where provided.	Single measurements.

Table 7.7.2-2 sheet 3

Requirements for extent of thickness measurement at those areas of Substantial Corrosion - Oil tankers with affixed **ESP** notation – within the cargo tank length

SHELL AND LONGITUDINAL BULKHEADS		
Structural member	Extent of measurement	Pattern of measurement
<i>Deckhead and bottom strakes and strakes in way of stringer platforms</i>	Plating between each pair of longitudinals in minimum of 3 bays.	Single measurement.
<i>All other strakes</i>	Plating between every 3rd pair of longitudinals in same 3 bays.	Single measurement.
<i>Longitudinals-deckhead and bottom strakes</i>	Each longitudinal in same 3 bays.	3 measurements across web and 1 measurement on flange.
<i>Longitudinals-all others</i>	Every third longitudinal in same 3 bays.	3 measurements across web and 1 measurement on flange.
<i>Longitudinals-brackets</i>	Minimum of three at top, middle and bottom of tank in same 3 bays.	5-point pattern over area of bracket.
<i>Web frames and cross ties</i>	3 webs with minimum of three locations on each web, including in way of cross tie connections.	5point pattern over about 2 square metre area, plus single measurements on web frame and cross tie face flats.

Table 7.7.2-2 sheet 4Requirements for extent of thickness measurement at those areas of Substantial Corrosion - Oil tankers with affixed **ESP** notation - within the cargo tank length

TRANSVERSE BULKHEADS AND SWASH BULKHEADS		
Structural member	Extent of measurement	Pattern of measurement
<i>Deckhead and bottom strakes and strakes in way of stringer platforms</i>	Plating between pair of stiffeners at three locations, i.e. approximately at 1/4, 1/2 and 3/4 width of tank.	5-points pattern between stiffeners over 1 meter length.
<i>All other strakes</i>	Plating between pair of stiffeners at middle location.	Single measurement.
<i>Strakes in corrugated bulkheads</i>	Plating for each change of scantling at centre of panel and at flange or fabricated connection.	5-point pattern over about 1 square metre of plating.
<i>Stiffeners</i>	Minimum of 3 typical stiffeners.	For web, 5-point pattern over span between bracket connections (2 measurements across web at each bracket connection, and one at centre of span). For flange, single measurements at each bracket toe and at centre of span.
<i>Brackets</i>	Minimum of three at top, middle and bottom of tank.	5-point pattern over areas of bracket.
<i>Deep webs and girders</i>	Measurements at toe of bracket and at centre of span.	For web, 5-point pattern over about 1 square metre. 3 measurements across face flat.
<i>Stringer platforms</i>	All stringers with measurements at middle and both ends.	5-point pattern over about 1 square metre of area plus single measurements near bracket toes and on face flats.

Table 7.7.4-1
Minimum requirements to Close-up survey - oil tankers with affixed **ESP** notation

I Renewal survey (age ≤ 5)	II Renewal survey (5 < age ≤ 10)	III Renewal survey (10 < age ≤ 15)	IV Renewal survey and all subsequent surveys (age > 15)
<ol style="list-style-type: none"> 1. One web frame ring (see A) in a wing ballast tank, if any, or a cargo wing tank used primarily for water ballast. 2. One deck transverse (see B) in a cargo oil tank. 3. One transverse bulkhead (see D): <ol style="list-style-type: none"> a) in a ballast tank, b) in a cargo wing tank, c) in a cargo oil center tank. 	<ol style="list-style-type: none"> 1. All web frame rings (see A) in a wing ballast tank, if any, or a cargo wing tank used primarily for water ballast. 2. One deck transverse (see B): <ol style="list-style-type: none"> a) in each of the remaining ballast tanks, if any, b) in cargo wing tank, c) in two cargo center tanks. 3. Both transverse bulkheads (see C) in a wing ballast tank, if any, or a cargo wing tank used primarily for water ballast 4. One transverse bulkhead (see D): <ol style="list-style-type: none"> a) in each remaining ballast tank, b) in a cargo oil wing tank, c) in two cargo center tanks. 	<ol style="list-style-type: none"> 1. All web frame rings (see A): <ol style="list-style-type: none"> a) in all ballast tanks, b) in a cargo wing tank. 2. A minimum of 30% of all web frame rings (see A and Note 1) in each remaining cargo wing tank. 3. All transverse bulkheads (see C) in all cargo and ballast tanks. 4. A minimum of 30% of deck and bottom transverses (see E) including adjacent structural members in each cargo centre tank. 5. The extent of survey can be expanded as considered necessary by the Surveyor (see F). 	<ol style="list-style-type: none"> 1. As for III Renewal survey. 2. Additional transverses included as deemed necessary by the Surveyor.
<p>NOTES:</p> <p>A) Complete transverse web frame ring including adjacent structural members. B) Deck transverse including adjacent deck structural members. C) Transverse bulkheads complete, including girder system and adjacent members. D) Transverse bulkhead lower part including girder system and adjacent structural members. E) Deck and bottom transverse including adjacent structural members. F) Additional transverse web frame ring.</p> <p>See sketches in Annex D for areas corresponding to (A), (B), (C), (D), (E) and (F).</p> <p>NOTE 1: The 30% is to be rounded up to next whole integer.</p>			

Table 7.7.5-1
Minimum additional requirements to tank testing - oil tankers

I Renewal survey (age ≤ 5)	II Renewal survey and Subsequent (age > 5)
1. All ballast tank boundaries.	1. All ballast tank boundaries.
2. Cargo tank boundaries facing ballast tanks, void spaces, pipe tunnels, representative fuel oil tanks, pump rooms or cofferdams.	2. All cargo tank boundaries
NOTES:	
a) Boundaries of ballast tanks are to be tested with a head of liquid to the top of air pipes.	
b) Boundaries of cargo tanks are to be tested to the highest point that liquid will rise under service conditions.	

Table 7.12.2-1
Minimum additional requirements to thickness measurement – general dry cargo ships

I Renewal survey (age ≤ 5)	II Renewal survey (5 < age ≤ 10)	III Renewal survey (10 < age ≤ 15)	IV Renewal survey and all subsequent surveys (age > 15)
1. Suspect areas.	1. Suspect areas. 2. One transverse section of deck plating abreast a cargo space within the amidships 0.5L 3. Measurement for general assessment and recording of corrosion pattern of those structural members subject to close-up survey according to Table 7.12.3-1	1. Suspect areas. 2. Two transverse sections within the amidships 0.5L abreast of two different cargo spaces. 3. Measurement for general assessment and recording of corrosion pattern of those structural members subject to close-up survey according to Table 7.12.3-1 4. Within the cargo length area, each deck plate outside line of cargo hatch openings. 5. All wind and water strakes within the cargo length area. 6. Selected wind and water strakes outside the cargo length area.	1. Suspect areas. 2. Within the cargo length area: a) A minimum of three transverse sections within the amidships 0.5L. b) Each deck plate outside line of cargo hatch openings. c) Each bottom plate, including lower turn of bilge. d) Duct keel or pipe tunnel plating and internals. 3. Measurement for general assessment and recording of corrosion pattern of those structural members subject to Close-up survey according to Table 7.12.3-1 4. All wind and water strakes full length.
NOTES:			
1. Thickness measurement locations should be selected to provide the best representative sampling of areas likely to be most exposed to corrosion, considering cargo and ballast history and arrangement and condition of protective coatings.			
2. For ships less than 100 metres in length, the number of transverse sections required at Renewal survey No. 3 may be reduced to one and the number of transverse sections at Renewal Survey No. 4 and subsequent-surveys may be reduced to two.			

Table 7.12.3-1
Minimum requirements to Close-up survey – at hull renewal surveys of general dry cargo ships

I Renewal survey (age ≤ 5)	II Renewal survey (5 < age ≤ 10)	III Renewal survey (10 < age ≤ 15)	IV Renewal survey and all subsequent surveys (age > 15)
<p>(A) Selected shell frames in one forward and one aft cargo hold and associated 'tween deck spaces.</p> <p>(B) One selected cargo hold transverse bulkhead.</p> <p>(D) All cargo hold hatch covers and coamings (plating and stiffeners).</p>	<p>(A) Selected shell frames in all cargo holds and 'tween deck spaces.</p> <p>(B) One transverse bulkhead in each cargo hold.</p> <p>(B) Forward and aft transverse bulkhead in one side ballast tank, including stiffening system.</p> <p>(C) One transverse web with associated plating and framing in two representative ballast tanks of each type (i.e. topside, hopper side, side tank or double bottom tank).</p> <p>(D) All cargo hold hatch covers and coamings (plating and stiffeners).</p> <p>(E) Selected areas of all deck plating and underdeck structure inside line of hatch openings between cargo hold hatches</p> <p>(F) Selected areas of inner bottom plating</p>	<p>(A) All shell frames in the forward lower cargo hold and 25% frames in each of the remaining cargo holds and 'tween deck spaces including upper and lower end attachments and adjacent shell plating.</p> <p>(B) All cargo hold transverse bulkheads.</p> <p>(B) All transverse bulkheads in ballast tanks, including stiffening system.</p> <p>(C) All transverse webs with associated plating and framing in each ballast tank.</p> <p>(D) All cargo hold hatch covers and coamings (plating and stiffeners).</p> <p>(E) All deck plating and underdeck structure inside line of hatch openings between cargo hold hatches.</p> <p>(F) All areas of inner bottom plating.</p>	<p>(A) All shell frames in all cargo holds and 'tween deck spaces including upper and lower end attachments and adjacent shell plating.</p> <p>Areas (B) - (F) as for Renewal survey No. III</p>
<p>(A) Cargo hold transverse frames.</p> <p>(B) Cargo hold transverse bulkheads plating, stiffeners, and girders.</p> <p>(C) Transverse web frame or watertight transverse bulkhead in ballast tanks.</p> <p>(D) Cargo hold hatch covers and coamings. Subject to cargo hold hatch covers of approved design which structurally have no access to the internals, close-up survey/thickness measurement shall be done of accessible part of hatch cover structures.</p> <p>(E) Deck plating inside line of hatch openings between cargo hold hatches.</p> <p>(F) Inner bottom plating.</p> <p>See sketches in Annex D for areas corresponding to (A), (B), (C), (D) (E) and (F).</p> <p>NOTES:</p> <p>Close-up survey of transverse bulkheads is to be carried out at the following levels:</p> <p>Level (a) –Immediately above the inner bottom and immediately above the 'tween decks, as applicable.</p> <p>Level (b) – Mid-height of the bulkheads for holds without 'tween decks.</p> <p>Level (c) – Immediately below the main deck plating and 'tween deck plating.</p>			

8 RENEWAL SURVEY REQUIREMENTS FOR MACHINERY

For Annual surveys see 4.4

8.1 PROPULSION SYSTEM - SURVEY REQUIREMENTS

8.1.1 The following parts are to be opened out and examined: cylinders with their liners, pistons, piston rods, cross-heads, guides, connecting rods, crankshafts and all bearings, crankcases, valves and valve gear, crankcase door fastenings and explosion relief devices, scavenge relief devices, scavenge pumps, scavenge blowers, air compressors and their inter-coolers, filters and/or separators and safety devices, fuel pumps and fittings, camshaft drives and balancer units, flexible couplings, clutches, reverse gears, attached pumps and cooling arrangements, superchargers and their associated coolers, vibration dampers or de-tuners.

8.1.2 Bedplates and holding down bolts and chocks of main and auxiliary engines are to be examined.

8.1.3 Selected pipes in the starting air system are to be removed for internal examination and are to be hammer and hydraulically tested. Some of the pipes selected are to be those adjacent to the starting air valves at the cylinders and the discharge from the air compressors.

8.1.4 Initial starting arrangements including the electric ignition system, if fitted are to be tested. The manoeuvring of engines is to be tested under working conditions.

8.1.5 Propeller shafts and propellers are to be surveyed in accordance with the requirements of 10.

8.1.6 Intermediate shafts, thrust shaft, thrust block and all bearings are to be examined. The lower halves of bearings need not be exposed if alignment and wear are found to be acceptable.

8.2 MACHINERY VERIFICATION RUNS

8.2.1 As part of the Renewal survey of the machinery, a dock trial is to be carried out to attending Surveyors' satisfaction to confirm satisfactory operation of main and auxiliary machinery.

If significant repairs are carried out to main or auxiliary machinery or steering gear, consideration should be given to a sea trial to attending Surveyors' satisfaction.

8.2.2 If the significant repairs as stated in 8.2.1, is considered by *Register* to have any impact on response characteristics of the propulsion systems, then the scope of sea trial shall also include a test plan for astern response characteristics based on those required for such an equipment or systems when fitted to the new ship. Refer to the *Rules for the classification of ships, Part 9 – Machines*, 2.14.13 for astern testing requirements.

The tests are to demonstrate the satisfactory operation of the equipment or system under realistic service con-

ditions at least over the manoeuvring range of the propulsion plant, for both ahead and astern directions. Depending on the actual extent of the repair, the *Register* may accept a reduction of the test plan.

8.3 AUXILIARY MACHINERY - SURVEY REQUIREMENTS

8.3.1 Sea water pumps, fire pumps, bilge and ballast pumps are to be opened out and examined. All safety devices for the aforementioned items are to be examined.

8.3.2 Screw and gear pumps as well as centrifugal and reciprocating pumps of systems other than those mentioned 8.3.1 are to be examined under working conditions, including check of stand-by arrangements, safety and signalling devices and so far as possible pressure and capacity.

Complete or partial survey in opened conditions is to be carried out if aforementioned survey under working conditions reveal malfunctioning.

8.3.3 Air compressors with their inter-coolers and safety devices and steam operated evaporators and their safety valves are to be opened up and examined and tested under working conditions.

8.3.4 Main and auxiliary steering machinery, hydraulic pumps, safety devices, mechanical and hydraulic control devices are to be examined and tested under working conditions.

Complete or partial survey in opened out conditions is to be carried out if aforementioned survey under working conditions reveal malfunctioning.

8.3.5 Anchoring and mooring windlass are to be examined, including operational check, check of the brake and testing of safety devices.

8.3.6 Condensers, steam re-heaters and super-heaters which are not incorporated in the boilers are to be examined and if it is considered necessary they are to be hydrostatically tested to 1.5 times their maximum working pressure (never less than 1 bar above the working pressure).

Hydrostatic testing is to be carried out every second Renewal survey.

8.3.7 For survey of pressure vessels (air receivers, hydroforors, oil and feed water heaters including their safety devices) see 8.10.

8.3.8 All safety devices are to be examined in opened out conditions.

8.3.9 The extent of examination for prime movers and auxiliary machinery such as generators, pumps, compressors etc. is to be decided by the Surveyor taking into account of the type and general condition of prime mover, number of working hours and results of testing under conditions.

8.4 REDUCTION GEAR AND CLUTCHES - SURVEY REQUIREMENTS

8.4.1 Reduction gearing is to be opened and examined as considered necessary by the Surveyor in order to confirm

the condition of the gears, pinions, shafts, bearings and lubrication system.

8.4.2 Bearing wear and gear teeth wear as well as gear-tooth contact are to be examined.

If considered necessary by the Surveyor, gear-teeth are to be examined by non-destructive means.

The holding down bolts and chocks of gear cases are to be examined.

8.4.3 Rubber and friction parts of clutches are to be examined.

8.4.4 Reverse gear is to be tested under working conditions.

8.5 TURBINES - SURVEY REQUIREMENTS

8.5.1 Main and auxiliary turbines are to be opened and examined including nozzles, rotor with blading, bearings, stationary blading interstage packing and gland seals with oil barriers. Axial and radial clearance is to be measured.

8.5.2 Fastenings of turbine casings covers and turbine foundation arrangements are to be examined.

8.5.3 Operational test of the turbines is to be carried out if deemed necessary by the Surveyor.

8.5.4 Control gear, starting and reversing arrangements, safety and signalling devices are to be examined.

8.5.5 Condensers and their cooling water and condensate extraction pumps, flexible couplings and steam filter are to be examined.

8.5.6 The extent of examination for turbine supplying power to generator is to be decided by the Surveyor taking into account general condition of turbine, number of working hours, bearing clearances and results of testing under working conditions.

8.5.7 Where the propulsion steam turbines are of a well-known type, and fitted with rotor position indicators and vibration indicators of an approved type, as well as measuring equipment of steam pressure at proper locations along the steam flow, and the arrangements for change over in case of emergency operation of the plant are readily operable, the first Renewal survey may be limited to the examination of rotor bearings, thrust bearings and flexible couplings, provided the Surveyor has been satisfied from operation service records and power trials subsequent to the survey, that the turbine plant is in good working condition.

8.5.8 Turbine casings should be opened at the next Renewal survey and subsequent Renewal surveys.

8.6 BOILERS - SURVEY REQUIREMENTS

8.6.1 Water tube boilers used for main propulsion, including reheat boilers, all other boilers of essential service, and boilers of non-essential service having working pressure exceeding 3.5 bar and a heating surface exceeding 4,5 m², are to be surveyed internally twice in every five year period. The period between surveys will not exceed three (3) years.

At each survey, the boilers, superheaters, and economizers are to be examined internally on water-steam side and fire side. Boiler mountings and safety valves are to be examined at each survey and opened out as considered necessary by the *Register*.

When direct visual internal inspection is not feasible due to the limited size of the internal spaces, such as for small boilers and/or narrow internal spaces, this may be replaced by a hydrostatic pressure test or by alternative verifications as determined by the *Register*.

An extension of examination of the boiler of up to 3 months beyond the due date can be granted in exceptional circumstances (see the *Rules for the classification of ships, Part 1- General requirements, Chapter 1 - General information, 5.5.1*). An extension may be granted by the *Register* after the following is satisfactorily carried out:

- .1 External examination of the boiler.
- .2 Boiler safety valve relieving gear (easing gear) is to be examined and operationally tested.
- .3 Boiler protective devices operationally tested.
- .4 Review of the following records since the last boiler survey: operation, maintenance, repair history and feedwater chemistry.

Boilers should be suitably prepared for the examination and water-steam side and fire side are to be cleaned so as to permit careful examination. If due to construction of boiler the complete internal examination is not practicable, hydrostatic testing is to be carried out as agreed with the *Register*.

8.6.2 Review of the following records since the last boiler survey is to be carried out as part of the survey: operation, maintenance, repair history and feedwater chemistry. Subject to the results of visual inspection the Surveyor may require non-destructive examinations for detection of possible defects and thickness measurements of plating and shells, furnaces and tubes to be carried out.

Upon such examination results, the appropriate working pressure of the boiler is to be fixed in agreement with the *Register*.

8.6.3 External survey of boilers is to be carried out annually in the course of the annual survey of a ship. External examination of boiler, superheater and economiser including all relevant fittings, insulation, supports and fastening arrangements is to be carried out under working conditions.

8.6.4 Superheaters and economisers are to be examined internally (water-steam side) and externally (fire side). The principal mountings are to be internally examined with particular regard to studs for securing the valve bodies to boiler shell, and the remaining mountings may be only externally examined at the discretion of the Surveyor.

Safety valves are to be adjusted to lift at a pressure 1.03 to 1.05 times the working pressure.

8.6.5 The oil fuel burning system is to be examined under working conditions, fuel tank valves and pipes, and oil piping between pumps and burners are to be generally examined.

8.6.6 All safety, control and signalling devices are to be examined and tested so far as practicable.

8.6.7 Safety valves for auxiliary boilers may be adjusted at sea on the responsibility of the Chief Engineer (see 2.3.2). Such operation is to be recorded in the logbook for the purpose of subsequent ascertainment by the Surveyors.

8.7 PIPING AND PIPING ARRANGEMENT - SURVEY REQUIREMENTS

8.7.1 All piping systems used for essential services are to be examined and tested under working conditions including pipe joints, expansion joints, valves, cocks, flexible pipes and rubber connections and safety devices.

8.7.2 Filters and some selected pipes of oil fuel and lubrication oil systems are to be opened up and examined.

8.7.3 The valves, cocks and strainers of the bilge system, including emergency suction system in engine room are to be opened up as considered necessary by the Surveyor and together with pipes, are to be examined and tested under working conditions.

8.7.4 For compressed air pipes see 8.2.3.

8.7.5 For steam pipes see 8.8.

8.7.6 All remote controls for valves are to be tested.

8.7.7 Hydraulic oil control system filters are to be opened up and examined and piping tested under working conditions.

8.7.8 During tank surveys particular attention is to be paid to fresh water and ballast piping passing through cargo and bunker tanks and oil fuel, cargo and lubricating piping passing through ballast and freshwater tanks.

Where considered necessary by the Surveyor piping systems may require to be tested under working conditions.

8.7.9 Where on piping systems mentioned in 8.7.8 pipe joints are inside tank, hydrostatic test with maximum working pressure is to be carried out at every Renewal survey.

8.7.10 Fuel tanks which do not form part of the ship's structure are to be examined and if considered necessary by the pressure specified for new tanks. The tanks need not to be examined internally at first survey if they are found satisfactory on external inspection.

8.7.11 The mountings, fittings and remote controls of all oil fuel tanks are to be examined so far as practicable.

8.7.12 For existing ships, having $GT \geq 500$, navigating in navigation areas 1 to 4 and for all new ships, the protection of main and auxiliary engines high pressure fuel pipes is to be checked during the first survey of any kind and re-checked on Renewal surveys.

8.8 STEAM PIPES - SURVEY REQUIREMENTS

8.8.1 At each survey a selected number of main steam pipes, also of auxiliary steam pipes which are over 76 [mm] external diameter and supply steam for essential services at sea and have bolted joints are to be removed for internal examination, and are to be hydraulically tested to 1.5 times the working pressure. If these selected pipes are found satisfactory, the remainder need not to be tested. So far as is practicable the pipes are to be selected for examination and hydraulically tested in rotation, so that in the course of surveys all sections of the pipeline will be tested.

8.8.2 Where steam pipes described in 8.8.1 have instead of bolted, welded joint between the lengths of pipe and/or between pipes and valves, the welds are to be examined and if considered necessary by the Surveyor, crack detected.

Pipe ranges having welded joints are to be hydraulically tested to 1.5 times the working pressure.

8.8.3 Steam pipes in tanks are to be examined and hydraulically tested so far as practicable.

8.8.4 Condition of insulation is to be examined, and if considered necessary by the Surveyor partial or complete renewal of insulation may be required.

8.9 HEAT TRANSFER DEVICES - SURVEY REQUIREMENTS

8.9.1 Internal examination and tightness testing of the heater tubes to not less than working pressure is to be carried out.

8.9.2 Control and safety devices are to be checked.

8.9.3 Hydraulic examination is to be carried out according to agreement with the *Register*.

8.10 PRESSURE VESSELS - SURVEY REQUIREMENTS

8.10.1 All air receivers for essential services are to be cleaned internally and examined internally and externally, once every five years. If internal examination is not practicable the examination by non-destructive means and/or hydrostatic testing to the test pressure marked on the vessel or 1.3 times the working pressure is to be carried out as considered necessary by the Surveyor.

8.10.2 Subject to the results of visual inspection the Surveyor may require non-destructive examinations for detection of possible defects and thickness measurements of plating to be carried out. Upon such examination results, the appropriate working pressure of the pressure vessel is to be fixed in agreement with the *Register*.

8.10.3 Mountings, valves and safety devices are to be opened up and examined.

8.10.4 Safety devices are to be tested to 1.1 times the working pressure.

8.10.5 At least 10 % of all CO₂ bottles are to be internally examined and hydraulically tested, at intervals not exceeding 10 (ten) years.

Halon containers of existing fixed Halon fire-extinguishing systems are exempted from this requirement.

Irrespective thereof, on the occasion of recharging CO₂ bottles and Halon containers are to be tested, if the last test dates back 10 (ten) years or more.

If the total loss of CO₂ or Halon bottle content is greater than 10 % of the original quantity, the bottles in question should be recharged, internally examined and if found necessary hydraulically tested (the value of pressure test is marked on the bottle) according to the requirements in 7.4.2.

Following a hydraulic pressure test, the bottles/containers are to be carefully dried. Records from inspection/testing of pressure vessels are to be kept onboard.

NOTE: In the case when the Flag State Administration requirements differ from aforementioned, then specific requirements of the Administration shall be applied.

8.11 REQUIREMENTS FOR TESTING OF PERMANENTLY INSTALLED BREATHING GAS CONTAINERS ONBOARD DIVING VESSELS

8.11.1 At the first Renewal survey the following is to be performed:

- .1 External and internal survey, by intrascope if necessary.
- .2 If internal survey is not possible or if corrosion or other items of concern are found, hydraulic test to 1.25 of the design pressure.

8.11.2 At all subsequent Renewal surveys the following is to be performed:

- .1 External and internal survey, by intrascope if necessary.
- .2 Hydraulic test to 1.25 of the design pressure.

8.12 SURVEY OF TOWING WINCH EMERGENCY RELEASE SYSTEMS SUBJECT TO IACS UR M79

8.12.1 The Annual Survey requirements are to be carried out, with the additional instructions for renewal survey provided by the manufacturer, as appropriate, being followed.

8.12.2 The full functionality of the emergency release system is to be tested to the satisfaction of the surveyor. Testing may be conducted either during a bollard pull test or by applying the load against a strong point on the deck of the tug or the shore that is certified to the appropriate load.

8.12.3 The emergency release system is to be tested at a towline load that is equal to the lesser of 30% of the maximum design load or 80% of vessel bollard pull in both a normal power condition and power blackout condition to the satisfaction of the Surveyor.

9 SURVEY OF THE AUTOMATION SYSTEMS

9.1 GENERAL

9.1.1 For ships having periodically unattended machinery space and complying to the requirements of the Rules (see the *Rules for the classification of ships, Part 13 - Automation*), the Register may assign one of the following additional characters of class: **AUT 1**, **AUT 2** or **AUT 3** (see the *Rules for the classification of ships, Part 1 – General requirements, Chapter 1 - General information, 4.3*).

9.1.2 On ships built after 1st July 2002, with class notation AUT 1 an approved stamped copy of systematic “Maintenance and testing program for automation system” is to be kept onboard and presented at annual and renewal surveys.

9.2 ANNUAL SURVEY REQUIREMENTS

9.2.1 Requirements of the Annual survey are stated in 4.4.1.7.

9.3 RENEWAL SURVEY REQUIREMENTS

9.3.1 Survey of the automation systems for ships having additional character of class AUT 1

9.3.1.1 Automatic synchronising and load sharing in case of overload of the generator at work are to be tested.

9.3.1.2 Officer on duty alarm is to be tested at each location where the alarm (visual or audible) shall be transferred.

9.3.1.3 Sequential re-starting of essential machinery (propulsion, steering and safety of the ship) after generator blackout is to be tested.

9.3.1.4 Automatic start-up of all standby machinery is to be checked.

9.3.1.5 Bilge level alarms at the bridge main control station and accommodation area are to be tested.

9.3.1.6 Machinery safety alarm system warning faults in machinery, as well as machinery remote control from the bridge are to be checked under working conditions or by simulation if possible, including checking of communication means and signalling devices at navigation bridge and main control station.

9.3.1.7 Automation of electric generating plant is to be checked including automatic starting of electric generating sets and their sequential connection to the main switchboard busbars, and remote starting of the prime movers of electric generating plant from the main control station, including checking of their safety systems.

9.3.1.8 Engine room alarm system is to be checked for correct functioning by simulation so far as possible.

9.3.1.9 Monitoring system at main control station as well as remote starting and stopping of all pumps serving main and auxiliary machinery are to be checked for correct functioning.

9.3.1.10 Dead man alarm is to be tested.

9.3.1.11 For ships built after 1st July 2002, at annual and renewal survey, Surveyor is to examine and verify approved “Maintenance and testing program for automation system”.

9.3.2 Survey of the automation systems for ships having additional character of class AUT 2

9.3.2.1 The survey of the automation systems for ships having additional character of class **AUT 2** is to consist of requirements listed from 9.3.1.6 to 9.3.1.10.

9.3.3 Survey of the automation systems for ships having additional character of class AUT 3

9.3.3.1 The survey of the automation systems for ships having additional character of class **AUT 3** is to consist of requirements of 9.3.1 for systems fitted on board.

10 PROPELLER AND PROPELLER SHAFT SURVEY

For vessels delivered before 1st January 2016, the following requirements apply until the first shaft survey on or after 1st January 2016. After that, 10.6 applies.

10.1 FREQUENCY OF SURVEYS

If the Society with which the vessel is dually classed applies different intervals for shaft drawing the *Register* may apply the required interval of that Society.

10.1.1 Shafts having approved continuous liners or approved oil glands, or made of approved corrosion resistant materials, where the propeller is fitted to the shaft by means of approved: coupling flange or with keyed or keyless type attachments are to be completely surveyed at intervals of five years.

10.1.2 Other shafts fitted with continuous liners or made of approved corrosion resistant materials are to be completely surveyed at intervals not exceeding: three years for ships having single shaft arrangement, four years for ships having multi-shaft arrangements.

The interval for drawing may be raised:

- i) from three to a maximum of five years for single shafting arrangements, or
 - ii) from four to a maximum of five years for multi-shafting arrangements,
- in any of following cases:

- a) where the propeller is fitted to a keyed shaft taper the design details of which are approved, and a non-destructive examination is made at each survey by an approved crack-detection method of the after end of the cylindrical part of the shaft (from the after end of the liner, if any), and of about one third of the length of the taper from the large end, or
- b) where the propeller is fitted to a solid flange coupling at the aft end of the shaft, the shaft and its fittings are not exposed to corrosion, the design details are approved. Non-destructive examination of the fillet radius of the aft propeller shaft flange may be required if the visual examination of the area is not satisfactory, or
- c) where the propeller is fitted keyless to the shaft taper, the shaft is protected from seawater, the design details are approved, and a non-destructive examination is made at each survey by approved crack-detection method of the forward part of the aft shaft taper, or
- d) for propeller fitted on ships not engaged in international voyages (area of navigation 5 to 8).

10.1.3 Controllable pitch propellers are to be surveyed at the same intervals as the propeller shafts where they are fitted.

10.1.4 Special propulsion systems, such as rotating thrusters, vertical axis propellers and water jet units for main propulsion purposes as well as athwartship thrust propellers are to be completely surveyed at intervals not exceeding five years.

10.1.5 All other shafts are to be surveyed at intervals not exceeding 2.5 years (+/- six months).

10.1.6 For survey intervals see also Table 10.1-1.

10.2 COMPLETE SURVEY

10.2.1 Unless alternative means are provided to assure the condition of the shaft all propellers shafts are to be sufficiently withdrawn to permit entire examination and following is to be examined:

- .1 The after end of the cylindrical part of the shaft and forward one third of the shaft cone (in the case of the keyed propeller attachments the key is to be removed), or fillet of the flange (in case of shafts having solid coupling flanges at the after end) is to be examined by a surface crack-detection method such as magnetic particle or dye penetrant. Where the propeller is fitted to a solid flange coupling at the aft end of the shaft non-destructive examination of the fillet radius of the aft propeller shaft flange may be required if the visual examination of the area is not satisfactory.
- .2 Shafts are to be carefully examined throughout, particularly in way of the thread for the propeller nut, at the keyway, at the large end of the cone, at the ends of the liner(s) where in contact with sea water, at the junctions of the separate lengths of a liner, at the portion of shaft between separate lengths of liners and in way of couplings and their bolt holes.
- .3 Propeller shaft bearings are to be examined.
- .4 Parts of the stern tube oil gland (if fitted) are to be examined.
- .5 Propellers, including fastenings and securing arrangements are to be examined.
- .6 Clearance measurement of the propeller shaft bearings are to be carried out.
- .7 Tightness test of the stern tube oil glands is to be carried out.
- .8 If considered necessary, controllable pitch propellers where fitted are to be opened-up, and the working parts examined, together with the control gear.

10.2.2 Where the notation **PMON** has been assigned, the propeller shaft need not be withdrawn at complete survey under the following conditions:

- .1 All exposed areas of the shaft are to be satisfactory examined by a surface crack-detection method. The crack detection test of the aft flange fillet area may be dispensed with for the solid flange coupling fitted at the end of the shaft. Where the propeller is fitted keyless to the shaft taper

- the crack detection test is to be carried out at intervals not exceeding 15 years.
- .2 Clearance of the aft sterntube bearing is to be checked and wear-down is to be acceptable.
 - .3 External examination of oil glands and propeller including fastenings and securing arrangements is to be satisfactory carried out.
 - .4 All condition monitoring data, as requested in 10.7, are to be found documented on board and within permissible limits.

Where the Surveyor considers that the data presented is not entirely to his satisfaction the shaft will be required to be withdrawn.

10.2.3 Rotating thrusters are to be subject to survey consisting of:

- .1 removing the propeller in order to examine as applicable: exposed parts, cone and keyway (to be checked using dye penetrant or magnetic particle method), sealing glands and threaded end and nut,
- .2 examining the results of a lub-oil analysis (see 10.5), to detect possible deterioration of internal gears and bearings,
- .3 examining the orientation device, as applicable.

Where the Surveyor considers that aforementioned checks and data presented are not satisfactory, dismantling of the internal parts may be required.

10.2.4 Vertical axis propellers are to be subject to survey consisting of:

- .1 checking the tightness of the oil glands and the backlash of the gears from outside by action on the blades;
- .2 checking the condition of gears and couplings from inside the ship;
- .3 examining the results of a lub-oil analysis (see 10.5), to detect possible deterioration of internal gears and bearings.

Where the Surveyor considers that aforementioned checks and data presented are not satisfactory, dismantling of the internal parts may be required.

10.2.5 Water jet systems are to be subject to survey consisting of:

- .1 examining the impeller, shaft and clearances of bearings;
- .2 checking the tightness of gland;
- .3 examining the water duct, aft deflector and its mechanism.

Where the Surveyor considers that aforementioned checks are not satisfactory, further dismantling may be required.

10.2.6 Athwartship thrust propellers are to be subject to survey consisting of:

- .1 checking the tightness of the oil glands and the backlash of the gears from outside by action on the blades,
- .2 checking the condition of gears and couplings from inside the ship,

- .3 examining the results of a lub-oil analysis (see 10.5), to detect possible deterioration of internal gears and bearings.

Where the Surveyor considers that aforementioned checks and data presented are not satisfactory, dismantling of the internal parts may be required.

10.3 MODIFIED SURVEY

10.3.1 Modified survey is applicable to the shafts described in 10.1.1 where oil glands are capable of being replaced without removal of the propeller.

10.3.2 Modified survey is accepted at alternate 5 (five) yearly surveys, provided that the clearances of the aft bearing are found in order and the oil and oil sealing arrangements have proved effective after the survey stated in 10.3.3. The due interval for complete survey in this case is 10 (ten) years.

10.3.3 The Modified survey is to consist of:

- .1 The partial withdrawal of the shaft, sufficient to ascertain the condition of the stern bearing and shaft in way of the propeller connection to the shaft.
- .2 Examination of fore bearing so far as is possible.
- .3 For keyed propellers, the after and of the cylindrical part of the shaft cone is to be examined by a surface crack-detection method (see 10.2.1.1), for which dismantling of the propeller and removal of the key will be required.
- .4 Measurement of the clearance/wear-down of the aft sterntube bearing.
- .5 Checking of the condition and efficiency of the oil sealing glands.
- .6 Examination of propellers, including fastenings and securing arrangements.
- .7 Controllable pitch propellers are to be subject to check of tightness in way of blade glands and distribution box, check of analyses of hydraulic oil, and to working test, as far as practicable, of the blade manoeuvring. Where the Surveyor considers that the data presented are not entirely to his satisfaction, further dismantling may be required.

10.3.4 Where the notation **PMON** has been assigned and all condition monitoring data, as requested in 10.7, are found documented on board and within permissible limits, partial withdrawal of the shaft need not be required at modified survey.

Where doubt exists regarding any of the above findings the shaft is to be withdrawn to permit an entire examination.

10.4 PARTIAL SURVEY

10.4.1 For propeller shafts where the Modified survey is applicable, upon application by the Company, the *Register* will be prepared to give consideration to postponement of the survey for a maximum period of half the specified cycle provided a Partial survey is held.

- 10.4.2** The Partial survey is to consist of:
- .1 The propeller being backed off in any keyed shaft and the top half of the cone examined by an efficient surface crack-detection method for which removal of the key will be required.
 - .2 The external examination of the oil gland sealing.
 - .3 Measurement of the clearance/wear-down of the aft sterntube bearing.
 - .4 Examination of propellers, including fastenings and securing arrangements.

10.4.3 The *Register* will be prepared to give consideration to the circumstances of any special case upon application by the Company.

10.5 DETERMINATION OF METALS AND OTHER CONTAMINANTS IN STERN TUBE LUBRICANTS

10.5.1 Determination of metals and other contaminants in stern tube lubricating oil

10.5.1.1 Where lubrication oil analysis is carried out, each analysis is to be performed by an appropriate method and should include the minimum parameters as follows:

- .1 Water contents.
- .2 Chloride contents.
- .3 Contents of bearing metal particles.
- .4 Oil ageing (resistance to oxidation).

10.5.1.2 Oil samples should be taken under service conditions, i.e. with a rotating shaft and the system at service temperature.

These samples, unless supervised by the Surveyor, are to be collected and identified by the Chief Engineer.

10.5.1.3 The contents of the following metals should be determined:

- .1 In connection with contents of wear metals:
 - a) chromium,
 - b) copper,
 - c) iron,
 - d) lead,
 - e) nickel,
 - f) silicon,
 - g) tin.
- .2 In connection with contents of sea water:
 - a) magnesium,
 - b) sodium.

10.5.1.4 The metal and water content values should be considered taking into account the type of seals used and the chemicals composition of the bearing material.

Suggested upper limits are given below for guidance only:

water	1%	nickel	10 ppm
chromium	10 ppm	silicon	40 ppm
copper	50 ppm	tin	10 ppm
iron	30 ppm	magnesium	30 ppm
lead	10 ppm	sodium	80 ppm
chloride content in water	70 ppm (ingress of salt water)		

These limits should be considered versus the elapsed time.

It is important to have results of a number of sequential analysis in order to observe any trends taking place.

10.5.1.5 Oxidation characteristics such as Total Acid Number (TAN), viscosity and oil appearance depend upon the type of oil used. Hence no recommended value is listed. Instead observation of any trends (such as viscosity and change in colour etc.) based on sequential analysis should be made. TAN is adversely influenced by oxidation for most typical oil lubricant types and also by hydrolysis in the case of unsaturated Environmentally Acceptable Lubricants (EALs). Observation of any trends on TAN should be made based on sequential analysis in conjunction with the limits defined by the oil maker for continued use in service.

10.5.1.6 Other analysis - Microscopic analysis of the particles may be recommended to identify the failure process and, where applicable, non-metallic bearing or seal material.

10.5.2 Determination of metals and other contaminants in a closed fresh water system lubricated stern tube

10.5.2.1 Where lubricating fresh water analysis is carried out, each analysis is to be performed by an appropriate method and should include the minimum parameters as listed:

- .1 Metal contents as applicable (with the material of the shaft and liners used), refer to 10.5.2.3 and 10.5.2.4,
- .2 Corrosion inhibitors in fresh water (pH or equivalent alkalinity indicators) indicating the degree of passivation of the system against corrosion, refer to 10.5.2.5,
- .3 Salinity indicators or equivalent indicators, i.e. total conductivity, refer to 10.5.2.3 and 10.5.2.6,
- .4 Contents of bearing particles - refer to 10.5.2.7.

Analysis result records should also include the extent of make-up water in the system.

10.5.2.2 Sampling procedure

One lubricating fresh water sample should be taken:

- .1 The fresh water sample should be taken under service conditions, i.e. with a rotating shaft and the system at service temperature,
- .2 The sample is to be drawn from the same agreed position in the system which should be positively identified. The sample should

be representative of the water circulating within the stern tube,

- .3 The sample, unless supervised by a Surveyor, is to be collected under the direct supervision of the Chief Engineer.

10.5.2.3 Contaminants determination

The presence of the following contaminants should be determined:

- .1 In connection with presence of wear metals and corrosion products (shaft and/or liners):
- a) iron,
 - b) chromium,
 - c) nickel,
 - d) copper,
 - e) silicon.
- .2 In connection with presence of sea water:
- a) sodium,
 - b) chlorides.

10.5.2.4 Metal content values

The metal content values should be considered taking into account the chemical composition of the shaft and liner materials.

Suggested upper limits are given below for guidance only:

Metal	Limit value
Iron	25ppm
Chromium	5ppm
Nickel	5ppm
Copper	40ppm
Silicon	30ppm

These limits should be considered versus the elapsed time.

It is important to have results of a number of sequential analyses in order to observe any trends taking place.

In case of shafts provided with a corrosion protection system the possible presence of further metal contaminants should be evaluated in accordance to the indications of the shaft/system manufacturer.

10.5.2.5 Corrosion inhibitors

The fresh water used for shaft lubrication may be treated, according to the provisions of the system manufacturer, by means of corrosion inhibitors that limit the risk of oxidation of the shaft and/or liners. The characteristics and contents of such inhibitors may vary, hence no recommended value is listed.

However, a significant indicator that may be used as guidance is the pH value of the sample or an equivalent indicator of alkalinity. The lower limit of the pH value of the water that may be assumed as guidance is 11.

10.5.2.6 Salinity indicators

In order to evaluate the possible contamination of the fresh water with salt water (e.g. leakages from the outboard seals) the following indicators should be considered:

- .1 Chloride contents,
- .2 Sodium.

Suggested upper limits are given below for guidance only:

Chloride contents	60ppm
Sodium	70ppm

10.5.2.7 Presence of bearing particles

The bearings used in fresh water lubricated propulsion shaft are made of synthetic material and could have composite structure consisting of specifically selected polymers and additives having mineral or synthetic origin.

The possible presence of synthetic material in the fresh water sample may indicate the deterioration of the bearing or onset of bearing failure.

Mechanical filtering of the water sample, e.g. by means of a paper micro-filter, may allow a first quantitative analysis of the content of macro parts. This shall be taken before the filters if any fitted in the system.

Microscopic analysis of the particles may be recommended to identify the non-metallic bearing material in the sample.

Table 10.1-1
Frequency of surveys for propellers and propeller shafts

SYSTEM/PART OF THE SHIP	SURVEY		NOTE
	type	due date (years)	
PROPELLERS - With fixed blades - With removable blades - With controllable pitch	see note	-	Survey interval is connected with the survey of related propeller shaft
- Rotating thrusters for main propulsion purposes - Vertical axis propellers for main propulsion purposes - Water jet units for main propulsion purposes - Athwartship thrust propellers	Complete	5	Unless prescribed by the manufacturer, dismantling of the internal parts may not be required, where the Surveyor considers that the checks and data presented are satisfactory (see also requirements in 10.2.3, 10.2.4, 10.2.5 and 10.2.6)
PROPELLER SHAFTS: <i>EXPLANATION:</i> Year stated in the diagram below denotes the due year of the Complete survey * Complete survey is to be held within six months before or after the due date in order to harmonise with the Docking survey			

10.6 SURVEYS OF PROPELLER SHAFTS AND TUBE SHAFTS

10.6.1 General

10.6.1.1 Application

Unless alternative means are provided to assure the condition of the propeller shaft assembly, these requirements apply to all vessels with conventional shafting fitted with a propeller as follows:

- from 1st January 2016 for ships delivered on or after 1st January 2016;
- after the first shaft survey scheduled on or after 1st January 2016, for ships delivered before 1st January 2016*.

NOTE: *Upon the completion of the first shaft survey scheduled on or after 1 January 2016, the designation of dates for the next shaft survey is to be made based upon Tables of Survey Intervals in 10.6.2 and 10.6.3.

10.6.1.2 Definitions

See also Diagram 1.

Shaft - For the purpose of this Rules shaft is a general definition that could mean:

- Propeller shaft
- Tube shaft

The definition does not include the intermediate shaft(s) which is(are) considered part of the propulsion shafting inside the vessel.

Propeller Shaft - is the part of the propulsion shaft to which the propeller is fitted. It may also be called screwshaft or tailshaft.

Tube Shaft - is a shaft placed between the intermediate shaft and propeller shaft, normally arranged within a stern tube or running in open water. It may also be called Stern Tube Shaft.

Stern tube - Tube or pipe fitted in the shell of a ship at the stern (or rear part of the ship), below the waterline, through which passes the tube shaft or aftermost section of the propeller-shaft. Stern tube is the housing of the shaft bearings, generally two (one aft and one fore), that sustain the shaft and allows its rotation with less frictional resistance. The stern tube also accommodates the shaft sealing arrangement.

Close Loop (system) Oil Lubricated bearing - Closed loop oil lubricating systems use oil to lubricate the bearings and are sealed against the environment (seawater) by adequate sealing / gland devices.

Water Lubricated Bearing - is a bearing cooled / lubricated by water (fresh or salt).

Closed Loop System Fresh Water Lubricated Bearing - Closed loop water lubricating systems use fresh water to lubricate the bearings and are sealed against the environment (such as seawater) by adequate sealing / gland devices.

Open Systems (water) - Open water lubricating systems use water to lubricate the bearings and are exposed to the environment.

Adequate means for protection against corrosion - An adequate means for protection against corrosion

is an approved means for full protection of the core shaft against sea water intrusion and subsequent corrosion attack. Such means are used for the protection of common steel material against corrosion particularly in combination with water lubricated bearings.

Typical means are for example:

- continuous metallic, corrosion resistant liners;
- continuous cladding;
- multiple layer synthetic coating;
- multiple layer of fiberglass;
- combinations of above mentioned;
- rubber / elastomer covering coating.

The means for protection against corrosion are installed / applied according to class approved procedures.

Corrosion Resistant Shaft - is made in approved corrosion resistant steel as core material for the shaft.

Stern tube Sealing System - is the equipment installed on the inboard extremity and, for closed systems, at outboard extremity of the stern tube.

Inboard Seal is the device fitted on the fore part of the stern tube that achieve the sealing against the possible leakage of the lubricant media in to the ship internal.

Outboard seal is the device fitted on the aft part of the stern tube that achieve the sealing against the possible sea water ingress and the leakage of the lubricant media.

Service records - Service records are regularly recorded data showing in-service conditions of the shaft(s) and may include, as applicable: lubricating oil temperature, bearing temperature and oil consumption records (for oil lubricated bearings) or water flow, water temperature, salinity, pH, make-up water and water pressure (for closed loop fresh water lubricated bearings depending on design).

Oil sample examination - is a visual examination of the stern tube lubricating oil taken in presence of the surveyor with a focus on water contamination.

Lubricating oil analysis - is to be carried out at regular intervals not exceeding six (6) months taking into account IACS Rec. 36.

The documentation on lubricating oil analysis is to be available on board.

Oil samples, to be submitted for the analysis, should be taken under service conditions.

Fresh Water sample test - should be carried out at regular intervals not exceeding six (6) months.

Samples are to be taken under service conditions and are to be representative of the water circulating within the stern tube.

Analysis results are to be retained on board and made available to the Surveyor.

At time of survey the sample for the test has to be taken at the presence of the Surveyor.

Fresh water sample test shall include the following parameters:

- chlorides content;
- pH value;
- presence of bearing particles or other particles (only for laboratory analysis, not required for tests carried out in presence of the Surveyor).

Keyless connection - is the forced coupling Methodology between the shaft and the propeller without a key achieved through interference fit of the propeller boss on the shaft tapered end.

Keyed connection - is the forced coupling Methodology between the shaft and the propeller with a key and keyway achieved through the interference fit of the propeller boss on the shaft tapered end.

Flanged connection - is the coupling Methodology, between the shaft and the propeller, achieved by a flange, built in at the shaft aft end, bolted to propeller boss.

Alternative means - Shafting arrangements such as, but not limited to, an approved Condition Monitoring Scheme and / or other reliable approved means for assessing and monitoring the condition of the tail shaft, bearings, sealing devices and the stern tube lubricant system capable to assure the condition of the propeller shaft assembly with an equivalent level of safety as obtained by survey methods as applicable.

Diagram 1 - Typical Shafting Arrangement

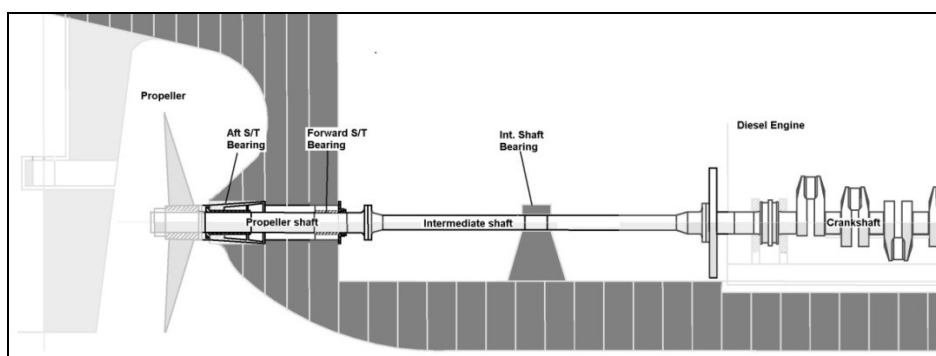

10.6.2 Oil Lubricated shafts or Closed Loop System Fresh Water Lubricated Shafts (closed system)

SHAFT SURVEY METHODS

10.6.2.1 Method 1

The survey is to consist of:

- .1 Drawing the shaft and examining the entire shaft, seals system and bearings.
- .2 For keyed and keyless connections:
 - Removing the propeller to expose the forward end of the taper,
 - Performing a non-destructive examination (NDE) by an approved surface crack-detection method all around the shaft in way of the forward portion of the taper section, including the keyway (if fitted). For shaft provided with liners the NDE shall extended to the after edge of the liner.
- .3 For flanged connection:
 - Whenever the coupling bolts of any type of flange-connected shaft are removed or the flange radius is made accessible in connection with overhaul, repairs or when deemed necessary by the surveyor, the coupling bolts and flange radius are to be examined by means of an approved surface crack detection method.
- .4 Checking and recording the bearing clearances.

- .5 Verification that the propeller is free of damages which may cause the propeller to be out of balance.
- .6 Verification of the satisfactory conditions of inboard and outboard seals during the re- installation of the shaft and propeller.
- .7 Recording the bearing wear-down measurements (after re-installation).

10.6.2.2 Method 2

The survey is to consist of:

- .1 For keyed and keyless connections:
 - Removing the propeller to expose the forward end of the taper,
 - Performing a non-destructive examination (NDE) by an approved surface crack-detection Method all around the shaft in way of the forward portion of the taper section, including the keyway (if fitted).
- .2 For flanged connection:
 - Whenever the coupling bolts of any type of flange-connected shaft are removed or the flange radius is made accessible in connection with overhaul, repairs or when deemed necessary by the surveyor, the coupling bolts and flange radius are to be examined by means of an approved surface crack detection Method.
- .3 Checking and recording the bearing wear-down measurements.
- .4 Visual Inspection of all accessible parts of the shafting system.

- .5 Verification that the propeller is free of damages which may cause the propeller to be out of balance.
- .6 Seal liner found to be or placed in a satisfactory condition.
- .7 Verification of the satisfactory re-installation of the propeller including verification of satisfactory conditions of inboard and outboard seals.

Pre-requisites to satisfactorily verify in order to apply Method 2:

- .1 Review of service records.
- .2 Review of test records of:
 - Lubricating Oil analysis (for oil lubricated shafts), or
 - Fresh Water Sample test (for closed system fresh water lubricated shafts).
- .3 Oil sample Examination (for oil lubricated shafts), or Fresh Water Sample test (for closed system fresh water lubricated).
- .4 Verification of no reported repairs by grinding or welding of shaft and/or propeller.

10.6.2.3 Method 3

The survey is to consist of:

- .1 Checking and recording the bearing wear-down measurements.
- .2 Visual Inspection of all accessible parts of the shafting system.
- .3 Verification that the propeller is free of damages which may cause the propeller to be out of balance.
- .4 Seal liner found to be or placed in a satisfactory condition.
- .5 Verification of the satisfactory conditions of inboard and outboard seals.

Pre-requisites to satisfactorily verify in order to apply Method 3:

- .1 Review of service records.
- .2 Review of test records of:
 - Lubricating Oil analysis (for oil lubricated shafts), or
 - Fresh Water Sample test (for closed system fresh water lubricated shafts).
- .3 Oil sample Examination (for oil lubricated shafts), or Fresh Water Sample test (for closed system fresh water lubricated).
- .4 Verification of no reported repairs by grinding or welding of shaft and/or propeller.

SHAFT EXTENSION SURVEYS - EXTENSION TYPES

10.6.2.4 Extension up to 2.5 years

The survey is to consist of:

- .1 Checking and recording the bearing wear-down measurements, as far as practicable.
- .2 Visual Inspection of all accessible parts of the shafting system.
- .3 Verification that the propeller is free of damages which may cause the propeller to be out of balance.

- .4 Verification of the effectiveness of the inboard seal and outboard seals.

Pre-requisites to satisfactorily verify in order to apply extension up to 2,5 years:

- .1 Review of service records.
- .2 Review of test records of:
 - Lubricating Oil analysis (for oil lubricated shafts), or
 - Fresh Water Sample test (for closed system fresh water lubricated shafts).
- .3 Oil sample Examination (for oil lubricated shafts), or Fresh Water Sample test (for closed system fresh water lubricated).
- .4 Verification of no reported repairs by grinding or welding of shaft and/or propeller.
- .5 Confirmation from the Chief Engineer that the shafting arrangement is in good working condition.

10.6.2.5

Extension up to 1 year

The survey is to consist of:

- .1 Visual Inspection of all accessible parts of the shafting system.
- .2 Verification that the propeller is free of damages which may cause the propeller to be out of balance.
- .3 Verification of the effectiveness of the inboard seal and outboard seals.

Pre-requisites to satisfactorily verify in order to apply extension up to 1 year:

- .1 Review of the previous wear-down and/or clearance recordings.
- .2 Review of service records.
- .3 Review of test records of:
 - Lubricating Oil analysis (for oil lubricated shafts), or
 - Fresh Water Sample test (for closed system fresh water lubricated shafts).
- .4 Oil sample Examination (for oil lubricated shafts), or Fresh Water Sample test (for closed system fresh water lubricated).
- .5 Verification of no reported repairs by grinding or welding of shaft and/or propeller.
- .6 Confirmation from the Chief Engineer that the shafting arrangement is in good working condition.

10.6.2.6

Extension up to 3 months

The survey is to consist of:

- .1 Visual Inspection of all accessible parts of the shafting system.
- .2 Verification of the effectiveness of the inboard seal.

Pre-requisites to satisfactorily verify in order to apply extension up to 3 months:

- .1 Review of the previous wear-down and/or clearance recordings.
- .2 Review of service records.
- .3 Review of test records of:
 - Lubricating Oil analysis (for oil lubricated shafts), or

- Fresh Water Sample test (for closed system fresh water lubricated shafts).
- .4 Oil sample Examination (for oil lubricated shafts), or Fresh Water Sample test (for closed system fresh water lubricated).
- .5 Verification of no reported repairs by grinding or welding of shaft and/or propeller.
- .6 Confirmation from the Chief Engineer that the shafting arrangement is in good working condition.

OIL LUBRICATED SHAFTS

10.6.2.7 Survey intervals

For surveys completed within 3 months before the shaft survey due date, the next period will start from the shaft survey due date.

- .1 Flanged propeller connection
The following Methods are applicable:
 - a) Method 1 every 5 years, or
 - b) Method 2 every 5 years (pre-requisites have to be fulfilled), or
 - c) Method 3 every 5 years (pre-requisites have to be fulfilled).
- .2 Keyless propeller connection
The following Methods are applicable:
 - a) Method 1 every 5 years, or
 - b) Method 2 every 5 years (pre-requisites have to be fulfilled), or
 - c) Method 3 every 5 years (pre-requisites have to be fulfilled). The maximum interval between two surveys carried out according to Method 1 or Method 2 shall not exceed 15 years, except in the case when one extension for no more than three months is granted.
- .3 Keyed propeller connection
The following Methods are applicable:
 - a) Method 1 every 5 years, or
 - b) Method 2 every 5 years (pre-requisites have to be fulfilled).

10.6.2.8 Survey extensions

For all types of propeller connections, the interval between two consecutive surveys may be extended after the execution of extension survey as follows:

- a) Extension up to a maximum of 2.5 years: no more than one extension can be granted. No further extension, of other type, can be granted.
- b) Extension up to a maximum of 1 year: no more than two consecutive “one-year extensions” can be granted. In the event an additional extension is requested, the requirements of the “2.5-year extension” are to be carried out and the shaft survey due date, prior to the previous extension(s), is extended for a maximum of 2.5 years.
- c) Extension up to a maximum of 3 months: no more than one “three months extension” can be granted. In the event an additional extension is requested the re-

quirements of the “one year extension” or “2.5 years extension” are to be carried out and the shaft survey due date, prior to the previous extension, is extended for a maximum of one year or 2.5 years.

The extension survey should normally be carried out within 1 month of the shaft survey due date and the extension counts from the shaft survey due date.

If the extension survey is carried out more than 1 month prior to the shaft survey due date, then the period of extension counts from the date of the extension survey was completed.

CLOSED LOOP SYSTEM FRESH WATER LUBRICATED SHAFTS

The maximum interval between two surveys carried out according to Method 1 shall not exceed 15 years. An extension for no more than three months can be granted.

10.6.2.9 Survey intervals

For surveys completed within 3 months before the shaft survey due date, the next period will start from the shaft survey due date.

- .1 Flanged propeller connection
The following Methods are applicable:
 - a) Method 1 every 5 years, or
 - b) Method 2 every 5 years (pre-requisites have to be fulfilled), or
 - c) Method 3 every 5 years (pre-requisites have to be fulfilled).
- .2 Keyless propeller connection
The following Methods are applicable:
 - a) Method 1 every 5 years, or
 - b) Method 2 every 5 years (pre-requisites have to be fulfilled), or
 - c) Method 3 every 5 years (pre-requisites have to be fulfilled).
- .3 Keyed propeller connection
The following Methods are applicable:
 - a) Method 1 every 5 years, or
 - b) Method 2 every 5 years (pre-requisites have to be fulfilled).

10.6.2.10 Survey extensions

For all types of propeller connections, the interval between two consecutive surveys may be extended after the execution of extension survey as follows:

- a) Extension up to a maximum of 2,5 years, no more than one extension can be granted. No further extension, of other type, can be granted.
- b) Extension up to a maximum of 1 year, no more than two consecutive extensions can be granted. In the event an additional extension is requested, the requirements of the “2.5-year extension” are to be carried out and the shaft survey due date, prior to the previous extension(s), is extended for a maximum of 2.5 years.
- c) Extension up to a maximum of 3 months, no more than one “three months extension” can be granted. In the event an additional extension is requested, the re-

quirements of the “one year extension” or “2.5-years extension” are to be carried out and the shaft survey due date, prior to the previous extension, is extended for a maximum of one year or 2.5 years.

The extension survey should normally be carried out within 1 month of the shaft survey due date and the extension counts from the shaft survey due date.

If the extension survey is carried out more than 1 month prior to the shaft survey due date, then the period of extension counts from the date of the extension survey was completed.

The maximum interval between two surveys carried out according to Method 1 shall not exceed 15 years, except in the case when one extension for no more than three months is granted.

Table 10.6.2 - Survey Intervals (closed systems)

SURVEY INTERVALS (closed systems)			
OIL LUBRICATED			
	Flanged Propeller Coupling	Keyless Propeller Coupling	Keyed Propeller Coupling ^b
Every five years ^a	Method 1 or Method 2 or Method 3	Method 1 or Method 2 or Method 3 ^c	Method 1 or Method 2
Extension 2,5 years	Yes ^d	Yes ^d	Yes ^d
Extension 1 year	Yes ^e	Yes ^e	Yes ^e
Extension 3 months	Yes ^f	Yes ^f	Yes ^f
CLOSED LOOP SYSTEM FRESH WATER LUBRICATED			
	Flanged Propeller Coupling	Keyless Propeller Coupling	Keyed Propeller Coupling ^b
Every five years ^a	Method 1 ^g or Method 2 or Method 3	Method 1 ^g or Method 2 or Method 3	Method 1 ^g or Method 2
Extension 2.5 years	Yes ^d	Yes ^d	Yes ^d
Extension 1 years	Yes ^e	Yes ^e	Yes ^e
Extension 3 months	Yes ^f	Yes ^f	Yes ^f
GENERAL NOTES:			
For surveys (Method 1, or Method 2, or Method 3) completed within 3 months before the shaft survey due date, the next period will start from the shaft survey due date.			
The extension survey should normally be carried out within 1 month of the shaft survey due date and the extension counts from the shaft survey due date. If the extension survey is carried out more than 1 month prior to the shaft survey due date, then the period of extension counts from the date of the extension survey was completed.			
NOTES:			
a: unless an Extension type (Extension 2.5 years, Extension 1 year, Extension 3 months) is applied in between.			
b: Method 3 not allowed.			
c: The maximum interval between two surveys carried out according to Method 1 or Method 2 shall not exceed 15 years, except in the case when one extension for no more than three months is granted.			
d: no more than one extension can be granted. No further extension of other type can be granted.			
e: no more than two consecutive extensions can be granted. In the event an additional extension is requested, the requirements of the “2.5-years extension” are to be carried out and the shaft survey due date, prior to the previous extension(s), is extended for a maximum of 2.5 years.			
f: no more than one three months extension can be granted. In the event an additional extension is requested the requirements of the “one-year extension” or “2.5-years extension” are to be carried out and the shaft survey due date, prior to the previous extension, is extended for a maximum of one year or 2.5 years.			
g: The maximum interval between two surveys carried out according to Method 1 shall not be more than 15 years.			

10.6.3 Water Lubricated shafts (open systems)

SHAFT SURVEY METHODS

10.6.3.1 Method 4

The survey is to consist of:

- .1 Drawing the shaft and examining the entire shaft (including liners, corrosion protection system and stress reducing features, where provided), inboard seal system and bearings.
- .2 For keyed and keyless connections:
 - removing the propeller to expose the forward end of the taper,
 - performing a non-destructive examination (NDE) by an approved surface crack-detection Method all around the shaft in way of the forward portion of the taper section, including the keyway (if fitted). For shaft provided with liners the NDE shall be extended to the after edge of the liner
- .3 For flanged connection:

Whenever the coupling bolts of any type of flange-connected shaft are removed or the flange radius is made accessible in connection with overhaul, repairs or when deemed necessary by the surveyor, the coupling bolts and flange radius are to be examined by means of an approved surface crack detection method.
- .4 Checking and recording the bearing clearances.
- .5 Verification that the propeller is free of damages which may cause the propeller to be out of balance.
- .6 Verification of the satisfactory conditions of inboard seal during re-installation of the shaft and propeller.

SHAFT EXTENSION SURVEYS – EXTENSION TYPES

10.6.3.2 Extension up to 1 year

The survey is to consist of:

- .1 Visual Inspection of all accessible parts of the shafting system.
- .2 Verification that the propeller is free of damages which may cause the propeller to be -out of balance.
- .3 Checking and recording the clearances of bearing.
- .4 Verification of the effectiveness of the inboard seal.

Pre-requisites to satisfactorily verify in order to apply extension up to 1 year:

- .1 Review of the previous clearance recordings.
- .2 Service records.
- .3 Verification of no reported repairs by grinding or welding of shaft and/or propeller.

- .4 Confirmation from the Chief Engineer that the shafting arrangement is in good working condition.

10.6.3.3 Extension up to 3 months

The survey is to consist of:

- .1 Visual Inspection of all accessible parts of the shafting system.
- .2 Verification that the propeller is free of damages which may cause the propeller to be out of balance.
- .3 Verification of the effectiveness of the inboard seal.

Pre-requisites to satisfactorily verify in order to apply extension up to 3 months:

- .1 Review of the previous clearance recordings.
- .2 Service records.
- .3 Verification of no reported repairs by grinding or welding of shaft and/or propeller.
- .4 Confirmation from the Chief Engineer that the shafting arrangement is in good working condition.

SHAFT SURVEY INTERVALS

10.6.3.4 Survey Intervals

The following survey intervals between surveys according to Method 4 are applicable to all types of propeller connections.

- .1 For keyless propeller connections the maximum interval between two consecutive dismantling and verifications of the shaft cone by means of non-destructive examination (NDE) shall not exceed 15 years.
- .2 For surveys completed within 3 months before the shaft survey due date, the next period will start from the shaft survey due date.

10.6.3.4.1 Configurations allowing 5-year intervals

- .1 Single shaft operating exclusively in fresh water.
- .2 Single shaft provided with adequate means of corrosion protection, single corrosion resistant shaft.
- .3 All kinds of multiple shafts arrangements.

10.6.3.4.2 Other systems

Shaft not belonging in one of the configurations listed in 10.6.3.4.1 has to be surveyed according to Method 4 every 3 years.

10.6.3.5 Survey extensions

For all types of propeller connections, the interval between two consecutive surveys may be extended after the execution of extension survey as follows:

- a) Extension up to a maximum of 1 year: no more than one extension can be granted. No further extension, of other type, can be granted.
- b) Extension up to a maximum of 3 months: no more than one “three months exten-

sion” can be granted. In the event an additional extension is requested the requirements of the “one-year extension” are to be carried out and the shaft survey due date prior to the previous extension is extended for a maximum of one year.

The extension survey should normally be carried out within 1 month of the shaft survey due date and the extension counts from the shaft survey due date.

If the extension survey is carried out more than 1 month prior to the shaft survey due date, then the period of extension counts from the date of the extension survey was completed.

Table 10.6.3 - Survey Intervals (open systems)

SURVEY INTERVALS (open systems)			
- Single Shaft operating exclusively in freshwater		Other shaft configuration	
- Single Shaft provided with adequate means of corrosion protection, Single corrosion resistant shaft			
- All kinds of Multiple shafts arrangements			
All kinds of Propeller Coupling ^d		All kinds of Propeller Coupling ^d	
Every five years ^a	Method 4	Every three years ^a	Method 4
Extension 1 year	Yes ^b	Extension 1 year	Yes ^b
Extension 3 months	Yes ^c	Extension 3 months	Yes ^c
General notes:			
For surveys (Method 4) completed within 3 months before the shaft survey due date, the next period will start from the shaft survey due date.			
The extension survey should normally be carried out within 1 month of the shaft survey due date and the extension counts from the shaft survey due date. If the extension survey is carried out more than 1 month prior to the shaft survey due date, then the period of extension counts from the date of the extension survey was completed.			
Notes:			
a: unless an Extension type (Extension 1 year, Extension 3 months) is applied in between.			
b: no more than one extension can be granted. No further extension, of other type, can be granted.			
c: no more than one extension can be granted. In the event an additional extension is requested the requirements of the one-year extension are to be carried out and the shaft survey due date prior to the previous extension is extended for a maximum of one year.			
d: For keyless propeller connections the maximum interval between two consecutive dismantling and verifications of the shaft cone by means of non-destructive examination (NDE) shall not exceed 15 years			

10.7 PROPELLER SHAFT CONDITION MONITORING (PMON)

10.7.1 The additional class notation **PMON** is assigned for propeller shaft arrangements fitted in accordance with requirements as stated in the *Rules for the classification of ships, Part 7 - Machinery installation, 2.9*. The assignment of **PMON** additional class notation allows a reduced scope for complete (see 10.2) and modified (see 10.3) propeller shaft survey.

10.7.2 Propeller shaft condition monitoring data system shall be established on board and the following condition monitoring data are to be found documented onboard and within permissible limits:

- .1 **Lubricating oil analysis:** The stern tube lubricating oil analysis shall be carried out by a recognized laboratory, at regular intervals not exceeding six months. Testing is to be conducted for the parameters and under conditions stated in 10.5.1. Stern tube lubricating oil is to be tested and recorded monthly for water content by means of onboard test kit or recognized laboratory.
- .2 **Oil consumption:** The system's oil consumption shall be monitored and recorded monthly.
- .3 **Bearing temperature:** Stern tube bearing temperatures with corresponding sea water temperatures are to be monitored and recorded monthly.

All records are to be confirmed by a Chief Engineer and available to Surveyor for examination.

10.7.3 For maintenance of the additional class notation **PMON** following examination shall be performed annually:

- .1 Examination of record file with condition monitoring data collected, as stated in 10.7.2.
- .2 Testing of stern tube aft bearing temperature alarm and another propeller shaft monitoring equipment, as applicable.
- .3 Visual inspections of inner and outer shaft seal for leakage, as far as practicable.
- .4 If any overhauls were performed, complete oil changes or similar, this shall be recorded in record file.

11 ELECTRICAL EQUIPMENT

11.1 ANNUAL AND INTERMEDIATE SURVEYS

11.1.1 The requirements for the Annual survey stated in 4, and the requirements for the Intermediate Survey stated in 5 are to be complied with as far as applicable.

11.2 COMPLETE SURVEYS

11.2.1 All sources of electric power are to be visually examined. The following items are to be functionally tested, insulation resistance is to be measured, and they are to be opened out if deemed necessary by the Surveyor:

- .1 Main sources of electric power.
- .2 Shaft generators.
- .3 Emergency sources of power.
- .4 For rectifiers and batteries only functional testing is to be carried out.

NOTE: Measured insulation resistance between all insulated circuits and earth is to be not less than 1000 Ohm per Volt of nominal voltage.

11.2.2 Where the ship is electrically propelled the following items are to be functionally tested, insulation resistance is to be measured, (see NOTE in 11.2.1) and they are to be opened out if deemed necessary by the Surveyor:

- .1 Generators of the propulsion system.
- .2 Propulsion motors.
- .3 Ventilating plant (including cooling for thyristor rectifiers).
- .4 Control and regulating devices.

11.2.3 Electric power distribution system is to be examined, consisting of insulation resistance measurements (see also NOTE in 11.2.1):

- .1 Examination of the main switchboard, comprising examination of related components, measurement of the insulation resistance, functional testing, control of the parallel work and over current protective devices.
- .2 Examination of the emergency switchboard, comprising examination of related components, measurement of the insulation resistance, functional testing, as well as the control of its automatic change-over and safety devices.
- .3 Examination of the distribution boards of navigational and signalling lights, comprising visual examination, measurement of the insulation resistance and functional testing.
- .4 Examination of all other distribution boards, comprising visual examination, measurement of the insulation resistance and functional testing.
- .5 Examination of the cables connecting generators and main switchboard, comprising visual examination of the cable outer covering, cable-runs, passages and

penetrations, interconnections, and measurement of the insulation resistance.

- .6 Examination of the cables connecting essential services is to be carried out in accordance with the *Rules for the classification of ships, Part 12 - Electrical equipment*, 4.3. The extent of such examination is to be the same as for the examination stated in 11.2.3.5.

11.2.4 Electromotive drives, are to be examined consisting of measurement of the insulation resistance (see also NOTE in 11.2.1), and:

- .1 Examination of the electromotive drives concerned with essential services is to be carried out as it is stated in the *Rules for the classification of ships, Part 12 - Electrical equipment*, 4.3.
- .2 Visual inspection of all other electromotive drives is to be carried out, including measurement of the insulation resistance and functional testing in extent as deemed necessary by the Surveyor.

11.2.5 Examination of lighting armatures and lighting fittings for the following items:

- .1 Lighting of the emergency lighting.
- .2 Lighting in the areas essential for the ship's operation. In all other areas lighting is to be visually inspected, taking into account that detail inspection of such lighting may be requested if deemed necessary by the Surveyor.

11.2.6 Electrical equipment and installations in hazardous areas are to be examined in accordance with the requirements stated in the *Rules for the classification of ships, Part 12 - Electrical equipment*, 19.2.4. In addition to this the following is to be performed:

- .1 Examination of the lighting conductors.
- .2 Examination of cable outer covering.
- .3 Examination of cable glands, joint boxes and expansion connections.
- .4 Examination of cable penetrations through the bulkheads and decks.
- .5 Examination of the insulation-testing instruments.
- .6 Measurement of the insulation resistance in inert-gas conditions. (see also NOTE in 11.2.1).
- .7 Confirming that the type and design of the equipment comply with the approved documentation.
- .8 Examination in the pressurised enclosure, including alarm devices and interlocking in the case of low pressure.

11.2.7 Examination of the alarms (visual and audible) and safety devices, including functional testing is to be carried out for the following items:

- .1 Main propulsion system.
- .2 System of the main sources of electric power.
- .3 System of emergency sources of electric power.
- .4 Controllable pitch propeller system.

- .5 Steering gear system.
- .6 Insulation-testing instruments.
- .7 Watertight doors.

- 11.2.8** Examination of other arrangements comprises:
- .1 Functional testing of internal communication circuits.
 - .2 Functional testing of the engine telegraph.
 - .3 Functional testing of the incinerator.
 - .4 Visual inspection and insulation resistance measurement of the heating equipment. (see also NOTE in 11.2.1).
 - .5 Control of spare parts in accordance with the requirements stated in the *Rules for the classification of ships, Part 12 - Electrical equipment*, 21.

11.3 SURVEYS OF ELECTRICAL EQUIPMENT DURING DOCKING SURVEY

11.3.1 For tankers for oil, ships for ore/bulk/oil and ships for ore/oil five years old and over, 11.2 is to be complied with. In addition, the requirements stated in 6.2.1.6 are to be fulfilled.

12 REFRIGERATING PLANT

12.1 ANNUAL SURVEY REQUIREMENTS

12.1.1 Maintenance records are to be examined to verify that the refrigerating machinery has functioned satisfactorily since the previous Annual survey.

If the records are showing that refrigerating machinery operating parameters or refrigerant consumption are exceeding acceptable tolerances, appropriate action is to be taken in response of such malfunction.

12.1.2 All refrigerated cargo spaces are to be checked visually. For that purpose, such spaces are to be thoroughly cleaned and cleared, especially in normally inaccessible parts.

12.1.3 The refrigerating machinery is to be checked in operation. During this check, the delivery and discharge temperatures at the air coolers and at the brine coolers respectively, the temperatures of the refrigerated cargo spaces, or refrigerated cargo containers, of the ambient air, the cooling water inlet and outlet, the refrigerant in the condenser and evaporator to be determined.

12.1.4 The entire plant for the power supply, including the part of the electrical plant necessary for operation of electrical plant, is to be inspected externally. The Surveyor is to obtain the information required on the condition of the installation from the operating data records for the refrigerating and machinery installation and is then to decide whether individual machines will have to be opened up for inspection.

12.1.5 Insulation resistance measurements are to be carried out at the electrical plant. Any measurement protocols prepared on board may be considered.

12.1.6 All pressure vessels, including valves, fittings, and safety devices, are to be inspected externally.

12.1.7 If ammonia is used as refrigerant, the covers of one or more heat exchangers are to be taken off for inspection of the tube plates. Depending on the inspection result, the Surveyor may require further parts of the installation to be opened up for inspection.

12.1.8 The refrigerant and brine pipes and their insulation are to be examined externally, and the pipes are to be tested for tightness during operation.

12.1.9 In the refrigerated cargo spaces, the air coolers, the brine grids and direct expansion evaporators respectively, as well as circulating fans, are to be inspected during operation.

12.1.10 The defrosting devices are to be externally inspected. Where necessary, proof is to be furnished of their proper functioning.

12.1.11 Bilge coverings are to be opened-up. Bilges are to be checked as to their perfect condition. The drains of the upper spaces with their closing devices, the bilge pipes, and their suction strums, as well as the sounding pipes, are to be inspected. Hatches, doors, pipelines, thermometer tubes with their connections and fastenings, as well as watertight doors

and air ducts, are to be checked. Cemented parts where brine might seep into the bilges are to be inspected with particular care.

12.1.12 The insulation of all refrigerated cargo spaces, apparatus and piping is to be checked as to whether it is free from damages and dry, especially at positions where moisture may collect, e.g. in the bottom insulation underneath the hatches, underneath stringers and below decks.

12.1.13 The proper operation of dehydrators, thermometers and remote indicating thermometers is to be checked. The thermometers are to be correctly maintained and regularly calibrated by the Company (their accuracy is to be proven to the Surveyor as required).

12.1.14 The proper operation of air duct couplings for connecting refrigerated containers to the ship's own refrigerated installation is to be checked. Also, it is to be ascertained whether the air ducts are free from defects.

12.1.15 The controlled atmosphere system is to be examined, as practicable, as follows:

- .1 Examination of the monitoring and control systems under working condition;
- .2 External examination of all compressors and piping, including where provided carbon dioxide and ethylene scrubbers, carbon dioxide supply equipment and humidifiers;
- .3 Confirmation that the plant is set to automatically achieve and maintain design O₂ and CO₂ levels in all controlled atmosphere cargo spaces;
- .4 Confirmation of the satisfactory operation of all alarms and safety devices, including stopping devices, pressure and vacuum valves and gas analysers;
- .5 Confirmation that warning notices are posted on all hatch covers and doors leading to spaces under controlled atmosphere;
- .6 Confirmation that gas generating compartment or container complies with the requirements for hazardous area with regard to suitability of electrical equipment, ventilation, access, etc.;
- .7 Confirmation that all liquid seal traps on drains from cargo spaces such as the air cooler trays are in satisfactory condition;
- .8 Confirmation of satisfactory operation of positive pressure ventilation systems of all accessible spaces adjacent to spaces under controlled atmosphere including their controls;
- .9 Confirmation of satisfactory operation of humidifying systems (where fitted) and their monitoring equipment in all refrigerated cargo spaces;
- .10 Confirmation of availability of personal safety equipment.

12.2 RENEWAL SURVEY REQUIREMENTS

12.2.1 A general examination of the installation as detailed in 12.1 here before for the Annual survey is to be carried out.

12.2.2 The insulation of pipes or refrigerated spaces is to be part removed at random in places most likely to be subject to deterioration, especially in the vicinity of boilers and liquid fuel tanks. The condition of metal parts of hull and girders, meat rails and hooks, coils etc. is to be examined. All necessary precautions are to be taken at re-assembly so that air duct lining remains airtight.

12.2.3 Refrigerating plant safety devices are to be checked. Safety disks and pressure relief valves which appear defective are to be renewed.

12.2.4 The Surveyor is to be satisfied with the condition of compressors, condensers, condenser circulation and brine circulation pumps. The apparatuses are to be dismantled to the extent as deemed necessary by the Surveyor to enable the following:

- .1 For reciprocating compressors the examination of cylinders, valves, crankshafts, connecting rods, pistons, bearings, and safety devices is to be carried out.
- .2 For rotary pumps and compressors the examination of parts subject to wear and tear are to be carried out.
- .3 For condensers the examination of tube plates and tubes is to be carried out.

12.2.5 The requirements here before also apply to parts of prime movers of pumps, compressors and fans which are subject to wear and tear.

12.2.6 Inspection of the sea inlet and discharge valves for cooling water supply to the installation (possibly, within the scope of classification of the ship).

12.2.7 Hydraulic pressure tests on pressure vessels are to be carried out for the first time 10 (ten) years after initial operation, and subsequently, on the occasion of each Renewal survey. In the case of pressure vessels operated with refrigerants in close circuit, the periodical hydraulic pressure tests may be dispensed with.

12.2.8 The end covers of heat exchangers are to be removed for inspection of the tube plates and tubes.

12.2.9 When installation is more than 5 (five) years old, brine coils and coolers are to be pressure tested at 1.5 times the rated working pressure.

12.2.10 For direct expansion installation, condensers and coils may be pressure tested, if deemed necessary by the Surveyor, at 1.5 times the rated working pressure.

12.2.11 The spare parts are to be checked as to their completeness and proper condition.

12.2.12 The controlled atmosphere system is to be examined as follows:

- .1 All gastight spaces are to be tested for tightness.

- .2 All equipment is to be examined and opened-up as considered necessary by the Surveyor.
- .3 All equipment including alarms, controls, sampling systems and instrumentation is to be operated to the satisfaction of the Surveyor.

ANNEX A
Hull Surveys of Chemical Tankers

Annex A HULL SURVEYS OF CHEMICAL TANKERS

Contents:

	Page
1 GENERAL.....	1
1.1 APPLICATION	1
1.2 DEFINITIONS	1
1.3 REPAIRS.....	2
1.4 THICKNESS MEASUREMENTS AND CLOSE-UP SURVEYS	2
1.5 REMOTE INSPECTION TECHNIQUES (RIT).....	2
2 RENEWAL (SPECIAL) SURVEY	3
2.1 SCHEDULE	3
2.2 SCOPE.....	3
2.3 EXTENT OF OVERALL AND CLOSE-UP SURVEY.....	3
2.4 EXTENT OF THICKNESS MEASUREMENT.....	4
2.5 EXTENT OF TANK TESTING.....	4
2.6 CHEMICAL TANKERS OVER 10 YEARS OF AGE	4
3 ANNUAL SURVEY	5
3.1 SCHEDULE	5
3.2 SCOPE.....	5
4 INTERMEDIATE SURVEY	6
4.1 SCHEDULE	6
4.2 SCOPE.....	6
5 PREPARATION FOR SURVEY	7
5.1 SURVEY PROGRAMME.....	7
5.2 CONDITIONS FOR SURVEY	7
5.3 ACCESS TO STRUCTURES.....	8
5.4 EQUIPMENT FOR SURVEY.....	8
5.5 RESCUE AND EMERGENCY RESPONSE EQUIPMENT	8
5.6 SURVEY AT SEA OR AT ANCHORAGE.....	8
5.7 SURVEY PLANNING MEETING	9
6 DOCUMENTATION ON BOARD	11
6.1 GENERAL.....	11
6.2 SURVEY REPORT FILE.....	11
6.3 SUPPORTING DOCUMENTS	11
6.4 REVIEW OF DOCUMENTATION ON BOARD	11
7 PROCEDURES FOR THICKNESS MEASUREMENTS	12
7.1 GENERAL.....	12
7.2 CERTIFICATION OF THICKNESS MEASUREMENT FIRM	12
7.3 REPORTING	12
8 REPORTING AND EVALUATION OF SURVEY.....	13
8.1 EVALUATION OF SURVEY REPORT	13
8.2 REPORTING	13

1 GENERAL

1.1 APPLICATION

1.1.1 The requirements apply of all self-propelled Chemical tankers with integral tanks, i.e. vessels with Certificate of fitness for the carriage of dangerous chemicals in bulk. If a chemical tanker is constructed with both integral and independent tanks, these requirements are applicable only to that portion of the cargo length containing integral tanks.

Combined Gas carriers/Chemical tankers with independent tanks within the hull, are to be surveyed as gas carriers (as informative guidance only as the *Register* does not provide services for liquified gas carriers).

1.1.2 The requirements apply to surveys of hull structure and piping systems in way of cargo tanks, pump rooms, cofferdams, pipe tunnels, void spaces within the cargo area and all ballast tanks. The requirements are additional to the requirements applicable to the remainder of the ship. The requirements are not applicable for independent tanks on deck. Refer to subtitles 4.2, 5.2 and 7.2 in the *Rules for the classification of ships, Part 1 - General requirements, Chapter 5 - Surveys of ships in service*.

1.1.3 The requirements contain the minimum extent of examination, thickness measurements and tank testing. The survey is to be extended when substantial corrosion and/or structural defects are found and include additional Close-up survey when necessary.

1.2 DEFINITIONS

1.2.1 Chemical tanker

A Chemical tanker is a ship constructed or adapted and used for the carriage in bulk of any liquid product listed in Chapter 17 of the *International Code for The Construction And Equipment Of Ships Carrying Dangerous Chemicals In Bulk*, IBC Code.

1.2.2 Ballast tank

A Ballast tank is a tank which is used primarily for the carriage of salt water ballast.

A Combined Cargo / Ballast Tank is a tank which is used for the carriage of cargo or ballast water as a routine part of the vessel's operation and will be treated as a Ballast Tank. Cargo tanks in which water ballast might be carried only in exceptional cases per MARPOL 73/78, Annex I/13(3) are to be treated as cargo tanks.

1.2.3 Overall survey

An Overall survey is a survey intended to report on the overall condition of the hull structure and determine the extent of additional Close-up surveys.

1.2.4 Close-up survey

A Close-up survey is a survey where the details of structural components are within the close visual inspec-

tion range of the Surveyor, i.e. normally within reach of hand.

1.2.5 Transverse section

A transverse section includes all longitudinal members such as plating, longitudinals and girders at the deck, side, bottom, inner bottom and longitudinal bulkheads. For transversely framed vessels, a transverse section includes adjacent frames and their end connections in way of transverse sections.

1.2.6 Representative tank

Representative tanks are those which are expected to reflect the condition of other tanks of similar type and service and with similar corrosion prevention systems. When selecting representative tanks account is to be taken of the service and repair history onboard and identifiable critical structural areas and/or suspect areas.

1.2.7 Suspect area

Suspect areas are locations showing substantial corrosion and/or are considered by the Surveyor to be prone to rapid wastage.

1.2.8 Critical Structural Area

Critical Structural Areas are locations which have been identified from calculations to require monitoring or from the service history of the subject ship or from similar or sister ships (if available) to be sensitive to cracking, buckling or corrosion which would impair the structural integrity of the ship.

1.2.9 Substantial corrosion

Substantial corrosion is an extent of corrosion such that assessment of corrosion pattern indicate a wastage in excess of 75% of allowable margins, but within acceptable limits.

1.2.10 Corrosion Prevention System

A Corrosion Prevention System is normally considered a full hard protective coating.

Hard Protective Coating is usually to be epoxy coating or equivalent. Other coating systems which are neither soft nor semi-hard coatings, may be considered acceptable as alternatives provided that they are applied and maintained in compliance with the manufacturer's specification.

1.2.11 Coating condition

Coating condition is defined as follows:

GOOD - condition with only minor spot rusting.

FAIR - condition with local breakdown at edges of stiffeners and weld connections and/or light rusting over 20% or more of areas under consideration, but less than as defined for POOR condition.

POOR - condition with general breakdown of coating over 20% or more or hard scale at 10% or more, of areas under consideration.

NOTE: Reference is made to IACS Recommendation No. 87 “Guidelines for Coating Maintenance & Repairs for Ballast Tanks and Combined Cargo/Ballast Tanks on Oil Tankers”.

1.2.12. Cargo Area

Cargo Area is that part of the ship which contains cargo tanks, slop tanks and cargo/ballast pump-rooms, cofferdams, ballast tanks and void spaces adjacent to cargo tanks and also deck areas throughout the entire length and breadth of the part of the ship over the above mentioned spaces.

1.2.13 Special consideration

Special consideration or specially considered (in connection with close-up surveys and thickness measurements) means sufficient close-up inspection and thickness measurements are to be taken to confirm the actual average condition of the structure under the coating.

1.2.14 Prompt and Thorough Repair

A Prompt and Thorough Repair is a permanent repair completed at the time of survey to the satisfaction of the Surveyor, therein removing the need for the imposition of any associated condition of class.

1.2.15 Remote Inspection Techniques (RIT)

Remote Inspection Technique is a means of survey that enables examination of any part of the structure without the need for direct physical access of the surveyor (refer to IACS Recommendation No. 42 – “Guidelines for Use of Remote Inspection Techniques for surveys”).

1.3 REPAIRS

1.3.1 Any damage in association with wastage over the allowable limits (including buckling, grooving, detachment or fracture), or extensive areas of wastage over the allowable limits, **which affects or**, in the opinion of the Surveyor, **will affect** the vessel’s structural, watertight or weather-tight integrity, is to be **promptly and thoroughly** (see 1.2.14) repaired.

Areas to be considered include:

- bottom structure and bottom plating;
- side structure and side plating;
- deck structure and deck plating;
- watertight or oiltight bulkheads, and
- hatch covers and hatch comings, where fitted (combined carriers).

For locations where adequate repair facilities are not available, consideration may be given to allow the vessel to proceed directly to a repair facility. This may require discharging the cargo and/or temporary repairs for the intended voyage.

1.3.2 Additionally, when a survey results in the identification of structural defects or corrosion, either of which, in the opinion of the Surveyor, will impair the vessel’s fitness for continued service, remedial measures are to be implemented before the ship continues in service.

1.3.3 Where the damage found on structure mentioned in Para. 1.3.1 is isolated and of a localised nature which does not affect the ship’s structural integrity, consider-

ation may be given by the surveyor to allow an appropriate temporary repair to restore watertight or weather tight integrity and impose a condition of class in accordance with IACS PR 35, with a specific time limit.

1.4 THICKNESS MEASUREMENTS AND CLOSE-UP SURVEYS

1.4.1 In any kind of survey, i.e. renewal, intermediate, annual or other surveys having the scope of the foregoing ones, thickness measurements, when required by Table II, of structures in areas where close-up surveys are required shall be carried out simultaneously with close-up surveys.

1.4.2 Consideration may be given by the attending Surveyor to allow use of Remote Inspection Techniques (RIT) as an alternative to close-up survey. Surveys conducted using a RIT are to be completed to the satisfaction of the attending Surveyor.

1.5 REMOTE INSPECTION TECHNIQUES (RIT)

1.5.1 The RIT is to provide the information normally obtained from a close-up survey. RIT surveys are to be carried out in accordance with the requirements given here-in and the requirements of IACS Recommendation No. 42 – “Guidelines for Use of Remote Inspection Techniques” for surveys. These considerations are to be included in the proposals for use of a RIT which are to be submitted in advance of the survey so that satisfactory arrangements can be agreed with the *Register*.

1.5.2 The equipment and procedure for observing and reporting the survey using a RIT are to be discussed and agreed with the parties involved prior to the RIT survey, and suitable time is to be allowed to set-up, calibrate and test all equipment beforehand.

1.5.3 When using a RIT as an alternative to close-up survey, if not carried out by the *Register* itself, it is to be conducted by a firm approved as a service supplier according to UR Z17 and is to be witnessed by an attending surveyor of the *Register*.

1.5.4 The structure to be examined using a RIT is to be sufficiently clean to permit meaningful examination. Visibility is to be sufficient to allow for a meaningful examination. The *Register* is to be satisfied with the methods of orientation on the structure.

1.5.5 The Surveyor is to be satisfied with the method of data presentation including pictorial representation, and a good two-way communication between the Surveyor and RIT operator is to be provided.

1.5.6 If the RIT reveals damage or deterioration that requires attention, the Surveyor may require traditional survey to be undertaken without the use of a RIT.

2 RENEWAL (SPECIAL) SURVEY

2.1 SCHEDULE

2.1.1 Renewal surveys are to be carried out at 5 years intervals to renew the Certificate.

2.1.2 The first Renewal survey is to be completed within 5 years from the date of the initial survey and for the purpose of issuing the certificate and thereafter within 5 years from the credited date of the previous Renewal survey. However, an extension of validity of the certificate of 3 months maximum beyond the 5th year can be granted in exceptional circumstances. In this case, the next period of validity of the certificate will start from the expiry date of the Renewal survey before the extension was granted.

2.1.3 For surveys completed within 3 months before the expiry date of the Renewal survey, the next period of validity of the certificate will start from the expiry date of the Renewal survey. For surveys completed more than 3 months before the expiry date of the Renewal survey, the period of validity of the certificate will start from the survey completion date. In cases where the vessel has been laid up or has been out of service for a considerable period because of a major repair or modification and the owner elects to only carry out the overdue surveys, the next period of class will start from the expiry date of the Renewal survey. If the owner elects to carry out the next due Renewal survey, the period of class will start from the survey completion date.

2.1.4 The Renewal survey may be commenced at the 4th Annual survey and be progressed with a view to completion by the 5th anniversary date. When the Renewal survey is commenced prior to the 4th Annual survey, the entire survey is to be completed within 15 months if such work is to be credited to the Renewal survey.

2.1.5 Concurrent crediting to both Intermediate survey and Renewal survey for surveys and thickness measurements of spaces are not acceptable.

2.2 SCOPE

2.2.1 General

2.2.1.1 The Renewal survey is to include, in addition to the requirements of the Annual survey, examination, tests and checks of sufficient extent to ensure that the hull and related piping, as required in 2.2.1.3, is in a satisfactory condition and is fit for its intended purpose for the new period of validity of the certificate of 5 years to be assigned, subject to proper maintenance and operation and to periodical surveys being carried out at the due dates.

2.2.1.2 All cargo tanks, ballast tanks including double bottom tanks, pumprooms, pipe tunnels, cofferdams and void spaces bounding cargo tanks, decks and outer hull are to be examined, and this examination is to be supplemented by thickness measurement and testing as required in 2.4 and 2.5, to ensure that the structural integrity remains effective. The

aim of the examination is to be sufficient to discover substantial corrosion, significant deformation, fractures, damages or other structural deterioration, that may be present.

2.2.1.3 Cargo piping on deck and cargo and ballast piping within the above tanks and spaces are to be examined and operationally tested to working pressure to attending Surveyor's satisfaction to ensure that tightness and condition remain satisfactory. Special attention is to be given to any ballast piping in cargo tanks and any cargo piping in ballast tanks and void spaces, and Surveyors are to be advised on all occasions when this piping, including valves and fittings are open during repair periods and can be examined internally.

2.2.2 Dry dock survey

2.2.2.1 A survey in dry dock is to be a part of the Renewal survey. The overall and close-up surveys and thickness measurements, as applicable, of the lower portions of the cargo tanks and ballast tanks are to be carried out in accordance with the applicable requirements for Renewals surveys, if not already performed.

NOTE: Lower portions of the cargo and ballast tanks are considered to be the parts below light ballast water line.

2.2.3 Tank Protection

2.2.3.1 Where provided, the condition of the corrosion prevention system of cargo tanks is to be examined. A ballast tank is to be examined at subsequent annual intervals where:

- a) a **hard** protective coating has not been applied from the time of construction, or
- b) a soft or semi-hard coating has been applied, or
- c) substantial corrosion is found within the tank, or
- d) the **hard** protective coating is found to be in less than GOOD condition and the **hard** protective coating is not repaired to the satisfaction of the Surveyor.

Thickness measurements are to be carried out as deemed necessary by the Surveyor.

2.3 EXTENT OF OVERALL AND CLOSE-UP SURVEY

2.3.1 An Overall survey of all tanks and spaces is to **be carried out at each Renewal survey.**

2.3.2 The minimum requirements for Close-up surveys at Renewal survey are given in Table I. The survey of stainless steel tanks may be carried out as an overall survey supplemented by Close-up survey as deemed necessary by the Surveyor.

2.3.3 The Surveyor may extend the Close-up survey as deemed necessary taking into account the maintenance of the tanks under survey, the condition of the corrosion prevention system and also in the following cases:

- a) In particular, tanks having structural arrangements or details which have suffered defects in similar tanks or on similar ships according to available information.

- b) In tanks which have structures approved with reduced scantlings due to an approved corrosion control system.

2.3.4 For areas in tanks where hard protective coatings are found to be in a GOOD condition as defined in 1.2.11, the extent of Close-up surveys according to Table I may be specially considered.

2.4 EXTENT OF THICKNESS MEASUREMENT

2.4.1 The minimum requirements for thickness measurements at Renewal survey are given in Table II. Thickness measurement of stainless steel hull structure and piping may be waived, except for clad steel plating.

2.4.2 Provisions for extended measurements for areas with substantial corrosion, are given in Table IV, and as may be additionally specified in the Survey Programme as required by 5.1. These extended thickness measurements are to be carried out before the survey is credited as completed. Suspect Areas identified at previous surveys are to be examined. Areas of substantial corrosion identified at previous surveys are to have thickness measurements taken.

2.4.3 The Surveyor may further extend the thickness measurements as deemed necessary.

2.4.4 For areas in tanks where hard protective coating is found to be in a GOOD condition as defined in 1.2.11, the extent of thickness measurements according to Table II may be specially considered.

2.4.5 Transverse sections are to be chosen where the largest reductions are suspected to occur or are revealed from deck plating measurements.

2.4.6 In cases where two or three sections are to be measured, at least one is to include a ballast tank within 0.5L amidships.

2.5 EXTENT OF TANK TESTING

2.5.1 The minimum requirements for ballast tank testing at Renewal Survey are given in 2.5.3 and Table III. The minimum requirements for cargo tank testing at Renewal Survey are given in 2.5.4 and Table III. Cargo tank testing carried out by the vessel's crew under the direction of the Master may be accepted by the surveyor provided the following conditions are complied with:

- a) a tank testing procedure, specifying fill heights, tanks being filled and bulkheads being tested, has been submitted by the owner and reviewed by the *Register* prior to the testing being carried out;
- b) there is no record of leakage, distortion or substantial corrosion that would affect the structural integrity of the tank;
- c) the tank testing has been satisfactorily carried out within Renewal survey window not more than 3 months prior to the date of the survey on which the overall or close up survey is completed;
- d) the satisfactory results of the testing are

- e) recorded in the vessel's logbook;
- f) the internal and external condition of the tanks and associated structure are found satisfactory by the surveyor at the time of the overall and close up survey.

2.5.2 The Surveyor may extend the tank testing as deemed necessary.

2.5.3 Boundaries of ballast tanks are to be tested with a head of liquid to the top of air pipes.

2.5.4 Boundaries of cargo tanks are to be tested to the highest point that liquid will rise under service conditions.

2.5.5 The testing of double bottom tanks and other spaces not designed for the carriage of liquid may be omitted, provided a satisfactory internal examination together with an examination of the tank top is carried out.

2.6 CHEMICAL TANKERS OVER 10 YEARS OF AGE

2.6.1 Selected steel cargo pipes outside cargo tanks and ballast pipes passing through cargo tanks are to be:

- Thickness measured at random or selected pipe lengths to be opened for internal inspection.
- Pressure tested to the maximum working pressure.

Special attention is to be given to cargo/slop discharge piping through ballast tanks and void spaces.

3 ANNUAL SURVEY

3.1 SCHEDULE

3.1.1 Annual surveys are to be held within 3 months before or after anniversary date from the date of the initial survey of the ship for the purpose of issuing the certificate for the first time, or of the date credited for the last Renewal survey.

3.2 SCOPE

3.2.1 General

3.2.1.1 The survey is to consist of an examination for the purpose of ensuring, as far as practicable, that the hull and piping are maintained in a satisfactory condition and should take into account the service history, condition and extent of the corrosion prevention system of ballast tanks and areas identified in the survey report file.

3.2.2 Examination of the hull

3.2.2.1 Examination of the hull plating and its closing appliances as far as can be seen.

3.2.2.2 Examination of watertight penetrations as far as practicable.

3.2.3 Examination of weather decks

3.2.3.1 Examination of cargo tank openings including gaskets, covers, coamings and flame screens.

3.2.3.2 Examination of cargo tanks pressure/vacuum valves and flame screens.

3.2.3.3 Examination of flame screens on vents to all bunker tanks.

3.2.3.4 Examination of cargo, bunker and vent piping systems, including vent masts and headers.

3.2.4 Examination of cargo pump rooms and pipe tunnels if fitted.

3.2.4.1 Examination of all pumproom bulkheads for signs of chemical leakage or fractures and, in particular, the sealing arrangements of all penetrations of pumproom bulkheads.

3.2.4.2 Examination of the condition of all piping systems.

3.2.5 Examination of ballast tanks

3.2.5.1 Examination of Ballast Tanks where required as a consequence of the results of the Renewal Survey (see 2.2.3) and Intermediate Survey (see 4.2.2.1 and 4.2.2.2) is to be carried out. When considered necessary by the Surveyor, or when extensive corrosion exists, thickness measurements

are to be carried out and if the results of these thickness measurements indicate that Substantial Corrosion is found, the extent of thickness measurements is to be increased in accordance with Table IV. These extended thickness measurements are to be carried out before the survey is credited as completed. Suspect Areas identified at previous surveys are to be examined. Areas of substantial corrosion identified at previous surveys are to have thickness measurements taken.

4 INTERMEDIATE SURVEY

4.1 SCHEDULE

4.1.1 The Intermediate survey is to be held at or between either the 2nd or 3rd Annual survey.

4.1.2 Those items which are additional to the requirements of the Annual surveys may be surveyed either at or between the 2nd and 3rd Annual survey.

4.1.3 Concurrent crediting to both Intermediate survey and Renewal survey for surveys and thickness measurements of spaces are not acceptable.

4.2 SCOPE

4.2.1 General

4.2.1.1 The survey extent is dependent on the age of the vessel as specified in 4.2.2 to 4.2.4.

4.2.1.2 For weather decks, an examination as far as applicable of cargo, bunker, ballast, steam and vent piping systems as well as vent masts and headers is to be carried out. If upon examination there is any doubt as to the condition of the piping, the piping may be required to be pressure tested, thickness measured or both.

4.2.2 Chemical tankers between 5 and 10 years of age, the following is to apply:

4.2.2.1 For ballast tanks, an Overall Survey of Representative Tanks selected by the Surveyor is to be carried out. If such inspections reveal no visible structural defects, the examination may be limited to a verification that the hard protective coating remains in GOOD condition.

4.2.2.2 A Ballast Tank is to be examined at subsequent annual intervals where:

- a) a **hard** protective coating has not been applied from the time of construction, or
- b) a soft or semi-hard coating has been applied, or
- c) substantial corrosion is found within the tank, or
- d) the **hard** protective coating is found to be in less than GOOD condition and the **hard** protective coating is not repaired to the satisfaction of the Surveyor.

4.2.2.3 In addition to the requirements above, suspect areas identified at previous surveys are to be examined.

4.2.3 Chemical tankers between 10 and 15 years of age, the following is to apply

4.2.3.1 The requirements of the Intermediate Survey are to be to the same extent as the previous Renewal Survey as required in 2 and 5.1. However, pressure testing of cargo and ballast tanks is not required unless deemed necessary by the attending Surveyor.

4.2.3.2 In application of 4.2.3.1, the intermediate survey may be commenced at the second annual survey and be progressed during the succeeding year with a view to completion at the third annual survey in lieu of the application of 2.1.4.

4.2.3.3 In application of 4.2.3.1, an underwater survey may be considered in lieu of the requirements of 2.2.2.

4.2.4 Chemical Tankers over 15 years of age, the following is to apply:

4.2.4.1 The requirements of the Intermediate Survey are to be to the same extent as the previous Renewal Survey as required in 2 and 5.1. However, testing of cargo and ballast tanks is not required unless deemed necessary by the attending Surveyor.

4.2.4.2 In application of 4.2.4.1, the intermediate survey may be commenced at the second annual survey and be progressed during the succeeding year with a view to completion at the third annual survey in lieu of the application of 2.1.4.

4.2.4.3 In application of 4.2.4.1, a survey in dry dock is to be part of the intermediate survey. The overall and close-up survey and thickness measurements, as applicable, of the lower portions of the cargo tanks and water ballast tanks are to be carried out in accordance with the applicable requirements for intermediate surveys, if not already performed.

NOTE: Lower portions of the cargo and ballast tanks are considered to be the parts below light ballast water line.

5 PREPARATION FOR SURVEY

5.1 SURVEY PROGRAMME

5.1.1 The Owner in co-operation with the *Register* is to work out a specific Survey Programme prior to the commencement of any part of:

- the Renewal Survey,
- the Intermediate Survey for oil tankers over 10 years of age.

The Survey Programme at Intermediate Survey may consist of the Survey Programme at the previous Renewal Survey supplemented by the Executive Hull Summary of that Renewal Survey and later relevant survey reports.

The Survey Program is to be worked out taking into account any amendments to the survey requirements implemented after the last Renewal Survey carried out.

The Survey Programme is to be in a written format.

5.1.1.1 Prior to the development of the survey programme, the survey planning questionnaire is to be completed by owner, and forwarded to the *Register*.

5.1.2 In developing the Survey Programme, the following documentation is to be collected and consulted with a view to selecting tanks, areas, and structural elements to be examined:

- survey status and basic ship information;
- documentation on-board, as described in 6.2 and 6.3;
- main structural plans of cargo and ballast tanks (scantling drawings), including information regarding use of high tensile steels (HTS), clad steel and stainless steel;
- Executive Hull Summary;
- relevant previous damage and repair history;
- relevant previous survey and inspection reports from both the *Register* and the owner,
- information regarding the use of the ship's tanks, typical cargoes and other relevant data,
- details of the inert gas plant and tank cleaning procedures;
- information and other relevant data regarding conversion or modification of the ship's cargo and ballast tanks since the time of construction;
- description and history of the coating and corrosion protection system (previous class notations), if any;
- inspections by the Owner's personnel during the last 3 years with reference to structural deterioration in general, leakages in tank boundaries and piping and condition of the coating and corrosion protection system, if any;

- information regarding the relevant maintenance level during operation including port state control reports of inspection containing hull related deficiencies. Safety Management System non-conformities relating to hull maintenance, including the associated corrective action(s); and,
- any other information that will help identify suspect areas and critical structural areas.

5.1.3 The submitted Survey Programme is to account for and comply, as a minimum, with the requirements of Tables I, II 2.5 and 2.6 for Close-up survey, thickness measurement tank testing, and pipe testing, respectively, and is to include relevant information including at least:

- basic ship information and particulars;
- main structural plans (scantling drawings), including information regarding use of high tensile steels (HTS), clad steel and stainless steel;
- plan of tanks;
- list of tanks with information on use, corrosion prevention and condition of coating;
- conditions for survey (e.g., information regarding tank cleaning, gas freeing, ventilation, lighting, etc.);
- provisions and methods for access to structures;
- equipment for surveys;
- nomination of tanks and areas for close-up survey (per 2.3);
- nomination of sections for thickness measurement (per 2.4);
- nomination of tanks for tank testing (per 2.5), and the pipes that are to undergo pipe testing (per 2.6);
- identification of the thickness measurement company;
- damage experience related to the ship in question;
- critical structural areas and suspect areas, where relevant.

5.1.4 The *Register* will advise the Owner of the maximum acceptable structural corrosion diminution levels applicable to the vessel.

5.2 CONDITIONS FOR SURVEY

5.2.1 The Owner is to provide the necessary facilities for a safe execution of the survey.

5.2.1.1 In order to enable the attending surveyors to carry out the survey, provisions for proper and safe access are to be agreed between the owner and the *Register* and are to be in accordance with IACS PR 37.

5.2.1.2 Details of the means of access are to be provided in the survey planning questionnaire.

5.2.1.3 In cases where the provisions of safety and required access are judged by the attending surveyors not to be adequate, the survey of the spaces involved is to not proceed.

5.2.2 Tanks and spaces are to be safe for access. Tanks and spaces are to be gas free and properly ventilated. Prior to entering a tank, void or enclosed space, it is to be verified that the atmosphere in that space is free from hazardous gas and contains sufficient oxygen.

5.2.3 In preparation for survey and thickness measurements and to allow for a thorough examination, all spaces are to be cleaned including removal from surfaces of all loose accumulated corrosion scale. Spaces are to be sufficiently clean and free from water, scale, dirt, oil residues, etc. to reveal corrosion, deformation, fractures, damages, or other structural deterioration as well as the condition of the coating. However, those areas of structure whose renewal has already been decided by the owner need only be cleaned and descaled to the extent necessary to determine the limits of the areas to be renewed.

5.2.4 Significant illumination is to be provided to reveal significant corrosion, deformation, fractures, damages or other structural deterioration.

5.2.5 Where soft or semi-hard coatings have been applied, safe access is to be provided for the Surveyor to verify the effectiveness of the coating and to carry out an assessment of the conditions of internal structures which may include spot removal of the coating. When safe access cannot be provided, the soft or semi-hard coating is to be removed.

5.3 ACCESS TO STRUCTURES

5.3.1 For overall survey, means are to be provided to enable the Surveyor to examine the hull structure in a safe and practical way.

5.3.2 For close-up survey, one or more of the following means for access, acceptable to the Surveyor, is to be provided:

- permanent staging and passages through structures,
- temporary staging and passages through structures,
- hydraulic arm vehicles such as conventional cherry pickers, lifts and movable platforms,
- boats or rafts,
- portable ladders,
- other equivalent means.

5.3.3 For Surveys conducted by use of a remote inspection technique, one or more of the following means for access, acceptable to the Surveyor, is to be provided:

- Unmanned robot arm.
- Remote Operated Vehicles (ROV).
- Unmanned Aerial Vehicles / Drones.
- Other means acceptable to the Register.

5.4 EQUIPMENT FOR SURVEY

5.4.1 Thickness measurement is normally to be carried out by means of ultrasonic test equipment. The accuracy of the equipment is to be proven to the Surveyor as required.

5.4.2 One or more of the following fracture detection procedures may be required if deemed necessary by the Surveyor:

- radiographic equipment,
- ultrasonic equipment,
- magnetic particle equipment,
- dye penetrant.

5.4.3 Explosimeter, oxygen-meter, breathing apparatus, lifelines, riding belts with rope and hook and whistles together with instructions and guidance on their use are to be made available during the survey. A safety check-list is to be provided.

5.4.4 Adequate and safe lighting is to be provided for the safe and efficient conduct of the survey.

5.4.5 Adequate protective clothing is to be made available and used during the survey (e.g. safety helmet, gloves, safety shoes, etc.).

5.5 RESCUE AND EMERGENCY RESPONSE EQUIPMENT

5.5.1 If breathing apparatus and/or other equipment is used as 'Rescue and emergency response equipment' then it is recommended that the equipment should be suitable for the configuration of the space being surveyed.

5.6 SURVEY AT SEA OR AT ANCHORAGE

5.6.1 Survey at sea or at anchorage may be accepted provided the Surveyor is given the necessary assistance from the personnel onboard. Necessary precautions and procedures for carrying out the survey are to be in accordance with 5.1, 5.2, 5.3 and 5.4.

5.6.2 A communication system is to be arranged between the survey party in the tank and the responsible officer on deck. This system is to also include the personnel in charge of ballast pump handling if boats or rafts are used.

5.6.3 Surveys of tanks by means of boats or rafts may only be undertaken with the agreement of the Surveyor, who is to take into account the safety arrangements provided, including weather forecasting and ship response under foreseeable conditions and provided the expected rise of water within the tank does not exceed 0.25 m.

5.6.4 When rafts or boats are used for close-up surveys, the following conditions are to be observed:

- .1 only rough duty, inflatable rafts or boats, having satisfactory residual buoyancy and stability even if one chamber is ruptured, should be used;
- .2 the boat or raft should be tethered to the access ladder and an additional person should be stationed down the access ladder with a clear view of the boat or raft;
- .3 appropriate lifejackets should be available for all participants;
- .4 the surface of water in the tank should be calm (under all foreseeable conditions the expected rise of water within the tank should not exceed 0.25 m) and the water level stationary. On no account should the level of the water be rising while the boat or raft is in use;

- .5 the tank or space must contain clean ballast water only. Even a thin sheen of cargo on the water is not acceptable;
 - .6 at no time should the water level be allowed to be within 1 m of the deepest under deck web face flat so that the survey team is not isolated from a direct escape route to the tank hatch. Filling to levels above the deck transverses should only be contemplated if a deck access manhole is fitted and open in the bay being examined, so that an escape route for the survey party is available at all times. Other effective means of escape to the deck may be considered;
 - .7 if the tanks (or spaces) are connected by a common venting system, or inert gas system, the tank in which the boat or raft should be used should be isolated to prevent a transfer of gas from other tanks (or spaces).
- i. access direct from the deck via a vertical ladder and a small platform fitted approximately 2 m below the deck in each bay; or
 - ii. access to deck from a longitudinal permanent platform having ladders to deck in each end of the tank. The platform shall, for the full length of the tank, be arranged in level with, or above, the maximum water level needed for rafting of under deck structure. For this purpose, the ullage corresponding to the maximum water level is to be assumed not more than 3m from the deck plate measured at the midspan of deck transverses and in the middle length of the tank (See Figure 5.6.6-1).

5.6.5 Rafts or boats alone may be allowed for inspection of the under deck areas for tanks or spaces, if the depth of the webs is 1.5 m or less.

5.6.6 If the depth of the webs is more than 1.5 m, rafts or boats alone may be allowed only:

- .1 when the coating of the under deck structure is in GOOD condition and there is no evidence of wastage; or
- .2 if a permanent means of access is provided

If neither of the above conditions are met, then staging or an “other equivalent means” is to be provided for the survey of the under deck areas.

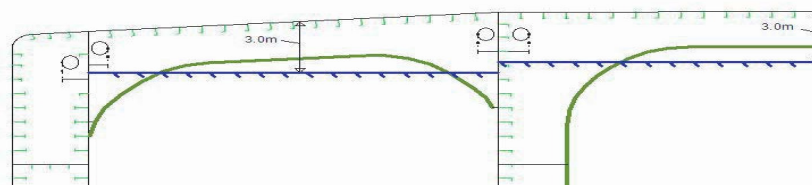

Figure 5.6.6-1

5.6.7 The use of rafts or boats alone in paragraphs 5.6.5 and 5.6.6 does not preclude the use of boats or rafts to move about within a tank during a survey.

NOTE: Reference is made to IACS Recommendation 39 – Guidelines for use of Boats or Rafts for Close-up Surveys.

5.7 SURVEY PLANNING MEETING

5.7.1 Proper preparation and close co-operation between the attending surveyor(s) and the owner’s representatives onboard prior to and during the survey are an essential part in the safe and efficient conduct of the survey. During the survey on board safety meetings are to be held regularly.

5.7.2 Prior to the commencement of any part of the Renewal and Intermediate Survey a survey planning meeting is to be held between the attending Surveyor(s), the Owner’s Representative in attendance and the TM company representative, where involved. and the master of the ship or an

appropriately qualified representative appointed by the master or Company for the purpose of ascertaining that all the arrangements envisaged in the survey programme are in place, so as to ensure the safe and efficient conduct of the survey work to be carried out. See also 7.1.2.

5.7.3 The following is an indicative list of items that are to be addressed in the meeting:

- .1 schedule of the vessel (i.e. the voyage, docking and undocking manoeuvres, periods alongside, cargo and ballast operations etc.);
- .2 provisions and arrangements for thickness measurements (i.e. access, cleaning/descaling, illumination, ventilation, personal safety);
- .3 extent of the thickness measurements;
- .4 acceptance criteria (refer to the list of minimum thicknesses);
- .5 extent of close-up survey and thickness

- measurement considering the coating condition and suspect areas/areas of substantial corrosion;
- .6 execution of thickness measurements;
 - .7 taking representative readings in general and where uneven corrosion/pitting is found;
 - .8 mapping of areas of substantial corrosion; and
 - .9 communication between attending surveyor(s) the thickness measurement company operator(s) and owner representative(s) concerning findings.

6 DOCUMENTATION ON BOARD

6.1 GENERAL

6.1.1 The Owner is to obtain, supply and maintain on board documentation as specified in 6.2 and 6.3, which is to be readily available for the Surveyor.

6.1.2 The documentation is to be kept on board for the life time of the ship.

6.2 SURVEY REPORT FILE

6.2.1 A Survey Report File is to be a part of the documentation on board consisting of:

- Reports of structural surveys,
- Executive Hull Summary,
- Thickness measurement reports.

6.2.2 The Survey Report File is to be available in the Owner's and the *Register's* management offices.

6.3 SUPPORTING DOCUMENTS

6.3.1 The following additional documentation is to be available onboard:

- Survey Programme as required by 5.1 until such time as the Renewal Survey or Intermediate Survey, as applicable, has been completed,
- main structural plans of cargo and ballast tanks,
- previous repair history,
- cargo and ballast history,
- extent of use of inert gas plant and tank cleaning procedures,
- inspections by ship's personnel with reference to:
 - structural deterioration in general,
 - leakage in bulkheads and piping,
 - condition of corrosion prevention system, if any,
 - a guidance for reporting is shown in Annex III C of IACS UR Z10.3.
- any other information that will help identify Critical Structural Areas and/or Suspect Areas requiring inspection.

6.4 REVIEW OF DOCUMENTATION ON BOARD

6.4.1 Prior to survey, the Surveyor is to examine the completeness of the documentation onboard, and its contents as a basis for the survey.

7 PROCEDURES FOR THICKNESS MEASUREMENTS

7.1 GENERAL

7.1.1 The required thickness measurements, if not carried out by the *Register* itself, are to be witnessed by a Surveyor of the *Register*. The Surveyor is to be on board to the extent necessary to control the process.

7.1.2 The thickness measurement firm is to be part of the survey planning meeting to be held prior to commencing the survey

7.1.3 Thickness measurements of structures in areas where close-up surveys are required shall be carried out simultaneously with close-up surveys.

7.1.4 In all cases the extent of the thickness measurements is to be sufficient as to represent the actual average condition.

7.2 CERTIFICATION OF THICKNESS MEASUREMENT FIRM

7.2.1 The thickness measurements are to be carried out by a qualified firm certified by the *Register* according to principles stated in the *Rules for the classification of ships, Part 1 - General requirements, Chapter 4 - Approval of manufacturers and service suppliers*.

7.3 REPORTING

7.3.1 A thickness measurement report is to be prepared. The report is to give the location of measurements, the thickness measured as well as corresponding original thickness. Furthermore, the report is to give the date when the measurements were carried out, type of measurement equipment, names of personnel and their qualifications and has to be signed by the operator.

7.3.2 The Surveyor is to review the final thickness measurement report and countersign the cover page.

8 REPORTING AND EVALUATION OF SURVEY

8.2 REPORTING

8.1 EVALUATION OF SURVEY REPORT

8.1.1 The data and information on the structural condition of the vessel collected during the survey is to be evaluated for acceptability and continued structural integrity of the vessel.

8.2.1 Principles for survey reporting are shown in the Annex II of IACS UR Z10.1.

8.2.2 When a survey is split between different survey stations, a report is to be made for each portion of the survey. A list of items examined and / or tested (pressure testing, thickness measurements etc.) and an indication of whether the item has been credited, are to be made available to the next attending Surveyor(s), prior to continuing or completing the survey.

8.2.3 An Executive Hull Summary of the survey and results is to be issued to the Owner and placed on board the vessel for reference at future surveys. The Executive Hull Summary is to be endorsed by the *Register's* Head Office.

Table I.1
MINIMUM REQUIREMENTS FOR CLOSE-UP SURVEYS AT RENEWAL SURVEY OF SINGLE SKIN CHEMICAL TANKERS

I Renewal survey (age ≤ 5 years)	II Renewal survey (5 years < age ≤ 10 years)	III Renewal survey (10 years < age ≤ 15 years)	IV Renewal and all subsequent surveys (age > 15 years)
A One web frame in a ballast wing tank	E All web frame – in a ballast wing tank or double bottom ballast tank (see Note 1)	E All web frame rings – in all ballast tanks	As for III Renewal survey
B One deck transverse in a cargo tank or on deck	B One deck transverse – in each remaining ballast tank or on deck B One deck transverse – in a cargo wing tank or on deck	A All web frame rings – in cargo wing tank	Additional transverse areas as deemed necessary by the <i>Register</i>
D One transverse bulkhead - lower part in a ballast tank	B One deck transverse – in two cargo centre tanks or on deck	A One web frame ring – in each remaining cargo tank	
D One transverse bulkhead - lower part in a cargo wing tank	C Both transverse bulkheads – in a ballast wing tank	C All transverse bulkheads – in all cargo tanks	
D One transverse bulkhead - lower part in a cargo centre tank (see Note 2)	D One transverse bulkhead – lower part in each remaining ballast tank D One transverse bulkhead – lower part in two cargo centre tanks (see Note 2) D One transverse bulkhead – lower part in a cargo wing tank	C All transverse bulkheads – in all ballast tanks	
NOTE 1: Ballast double hull tank – means double bottom tank plus double side tank plus double deck tank, as applicable, even though these tanks are separate.			
NOTE 2: Where no centre cargo tanks are fitted (as in the case of centre longitudinal bulkhead), transverse bulkheads in wing tanks are to be surveyed.			
A-D: are areas to be subjected to close-up surveys and thickness measurements (see Annex D)			
A) Complete transverse web frame ring including adjacent structural members.			
B) Deck transverse including adjacent deck structural members.			
C) Transverse bulkhead complete - including girder system and adjacent members.			
D) Transverse bulkhead lower part - including girder system and adjacent structural members.			

Table I.2
MINIMUM REQUIREMENTS FOR CLOSE-UP SURVEYS AT RENEWAL SURVEY OF DOUBLE SKIN CHEMICAL TANKERS

I Renewal survey (age ≤ 5 years)	II Renewal survey (5 years < age ≤ 10 years)	III Renewal survey (10 years < age ≤ 15 years)	IV Renewal and all subsequent surveys (age > 15 years)
1 One web frame ring in a ballast double hull tank (see Note I) 2 One deck transverse in a cargo tank or on deck 4 One transverse bulkhead – in a ballast tank (see Note I) 5 One transverse bulkhead in a cargo wing tank 5 One transverse bulkhead in a cargo centre tank (see Note II)	1 All web frame rings – in a ballast wing tank or ballast double hull tank (see Note I) 6 The knuckle area and the upper part (3 metres approx.) of one web frame in each remaining ballast tank 2 One deck transverse – in two cargo tanks 4 One transverse bulkhead - in each ballast tank (see Note I) 5 One transverse bulkhead – in two cargo centre tanks (see Note II) 5 One transverse bulkhead – in a cargo wing tank	1 All web frame rings – in all ballast tanks 7 All web frame rings – in cargo wing tank 7 One web frame ring – in each remaining cargo tank 3 All transverse bulkheads – in all cargo tanks 4 All transverse bulkheads – in all ballast tanks	As for III Renewal survey Additional transverse areas as deemed necessary by the <i>Register</i>
<p>(1), (2), (3), (4), (5), (6) and (7) are areas to be subjected to close-up surveys and thickness measurements (see Annex D).</p> <p>(1): Web frame in a ballast tank means vertical web in side tank, hopper web in hopper tank, floor in double bottom tank and deck transverse in double deck tank (where fitted), including adjacent structural members. In fore and aft peak tanks web frame means a complete transverse web frame ring including adjacent structural members.</p> <p>(2): Deck transverse, including adjacent deck structural members (or external structure on deck in way of the tank, where applicable).</p> <p>(3): Transverse bulkhead complete in cargo tanks, including girder system, adjacent structural members (such as longitudinal bulkheads) and internal structure of lower and upper stools, where fitted.</p> <p>(4): Transverse bulkhead complete in ballast tanks, including girder system and adjacent structural members, such as longitudinal bulkheads, girders in double bottom tanks, inner bottom plating, hopper side, connecting brackets.</p> <p>(5): Transverse bulkhead lower part in cargo tank, including girder system, adjacent structural members (such as longitudinal bulkheads) and internal structure of lower stool, where fitted.</p> <p>(6): The <i>knuckle area</i> and the upper part (5 metres approximately), including adjacent structural members. <i>Knuckle area</i> is the area of the web frame around the connections of the slope hopper plating to the inner hull bulkhead and the inner bottom plating, up to 2 metres from the corners both on the bulkhead and the double bottom.</p> <p>(7): Web frame in a cargo oil tank means deck transverse, longitudinal bulkhead vertical girder and cross ties, where fitted, including adjacent structural members.</p> <p>NOTE I: Ballast double hull tank: means double bottom tank plus double side tank plus double deck tank, as applicable, even if these tanks are separate.</p> <p>NOTE II: Where no centre cargo tanks are fitted (as in case of centre longitudinal bulkhead), transverse bulkheads in wing tanks are to be surveyed.</p>			

Table II
MINIMUM REQUIREMENTS FOR THICKNESS MEASUREMENT AT RENEWAL SURVEY OF
CHEMICAL TANKERS FOR WHICH ESP REQUIREMENTS APPLY

I Renewal survey (age ≤ 5 years)	II Renewal survey (5 years < age ≤ 10 years)	III Renewal survey (10 years < age ≤ 15 years)	IV Renewal and all subsequent surveys (age > 15 years)
1. Suspect areas.	1. Suspect areas.	1. Suspect areas.	1. Suspect areas.
	2. Within cargo area: - each deck plate, - one transverse section.	2. Within cargo area: - each deck plate, - two transverse sections (1), - all wind and water strakes.	2. Within cargo area: - each deck plate, - three transverse sections (1), - each bottom plate.
	3. Selected wind and water strakes outside cargo area	3. Selected wind and water strakes outside cargo area	3. All wind and water strakes, full length.
	4. Measurements for general assessment and recording of corrosion pattern, of those structural members subject to close-up survey according to Table I.1 or I.2, as applicable.	4. Measurements for general assessment and recording of corrosion pattern, of those structural members subject to close-up survey according to Table I.1 or I.2, as applicable.	4. Measurements for general assessment and recording of corrosion pattern, of those structural members subject to close-up survey according to Table I.1 or I.2, as applicable.
(I): At least one section is to include a ballast tank within 0,5 L amidships.			

Table III
MINIMUM REQUIREMENTS FOR TANK TESTING AT RENEWAL SURVEY OF CHEMICAL TANKERS FOR
WHICH ESP REQUIREMENTS APPLY

I Renewal survey (age ≤ 5 years)	II Renewal and all subsequent surveys (age > 5 years)
1. All ballast tank boundaries.	1. All ballast tank boundaries.
2. Cargo tank boundaries facing ballast tanks, void spaces, pipe tunnels, pumprooms or cofferdams.	2. All cargo tank boundaries.

Table IV, Sheet 1

REQUIREMENTS FOR EXTENT OF THICKNESS MEASUREMENTS AT THOSE AREAS OF SUBSTANTIAL CORROSION. RENEWAL SURVEY OF CHEMICAL TANKERS FOR WHICH ESP REQUIREMENTS APPLY WITHIN THE CARGO AREA LENGTH

BOTTOM, INNER BOTTOM AND HOPPER STRUCTURE		
Structural member	Extent measurement	Pattern of measurement
<i>Bottom, inner bottom and hopper structure plating</i>	Minimum of three bays across tank, including aft bay Measurements around and under all suction bell mouths	5 point pattern for each panel between longitudinals and floors
<i>Bottom, inner bottom and hopper structure longitudinals</i>	Minimum of three longitudinals in each bay where bottom plating measured	Three measurements in line across flange and three measurements on vertically web
<i>Bottom girders, including the watertight ones</i>	At fore and aft watertight floors and in centre of tanks	Vertical line of single measurements on girder plating with one measurement between each panel stiffener, or a minimum of three measurements. Two measurements across face flat where fitted
<i>Bottom floors, including the watertight ones</i>	Three floors in bays where bottom plating measured, with measurements at both ends and middle	5 point pattern over two square metre area
<i>Hopper structure web frame ring</i>	Three floors in bays where bottom plating measured	5 point pattern over one square metre of plating. Single measurements on flange
<i>Hopper structure transverse watertight bulkhead or swash bulkhead</i>	- lower 1/3 of bulkhead	5 point pattern over one square metre of plating
	- upper 2/3 of bulkhead	5 point pattern over two square metre of plating
	- stiffeners - (minimum of three)	For web, 5-point pattern over span (two measurements across web at each end and one at centre of span). For flange, single measurements at each end and centre of span
<i>Panel stiffening</i>	Where applicable	Single measurements

Table IV, Sheet 2

REQUIREMENTS FOR EXTENT OF THICKNESS MEASUREMENTS AT THOSE AREAS OF SUBSTANTIAL CORROSION. RENEWAL SURVEY OF CHEMICAL TANKERS FOR WHICH ESP REQUIREMENTS APPLY WITHIN THE CARGO AREA LENGTH.

DECK STRUCTURE		
Structural member	Extent measurement	Pattern of measurement
<i>Deck plating</i>	Two transverse bands across tank	Minimum of three measurements per plate per band
<i>Deck longitudinals</i>	Every third longitudinal in each of two bands with a minimum of one longitudinal	Three measurements in line vertically on webs, and two measurements on flange (if fitted)
<i>Deck girders and brackets</i>	At fore and aft transverse bulkhead, bracket toes and in centre of tanks	Vertical line of single measurements on web plating with one measurement between each panel stiffener, or a minimum of three measurements. Two measurements across flange. 5 point pattern on girder/bulkhead brackets
<i>Deck transverse webs</i>	Minimum of two webs with measurements at middle and both ends of span	5 points pattern over one square metre area. Single measurements on flange
<i>Vertical web and transverse bulkhead in wing ballast tank for double hull design (two metres from deck)</i>	Minimum of two webs, and both transverse bulkheads	5 point pattern over one square metre area
<i>Panel stiffening</i>	Where provided	Single measurements

Table IV, Sheet 3
REQUIREMENTS FOR EXTENT OF THICKNESS MEASUREMENTS AT THOSE AREAS OF
SUBSTANTIAL CORROSION
RENEWAL SURVEY OF CHEMICAL TANKERS FOR WHICH ESP REQUIREMENTS APPLY
WITHIN THE CARGO AREA LENGTH

SIDE SHELL AND LONGITUDINAL BULKHEADS		
Structural member	Extent measurement	Pattern of measurement
<i>Side shell and longitudinal bulkhead plating:</i> - Deckhead and bottom strakes, and strakes in way of horizontal girders - All other strakes	- Plating between each pair of longitudinals in a minimum of three bays (along the tank) - Plating between every third pair of longitudinals in same three bays	Single measurement
<i>Side shell and longitudinal bulkhead longitudinals on:</i> - Deckhead and bottom strakes - All other strakes	- Each longitudinal in same three bays - Every third longitudinal in same three bays	3 measurements across web and 1 measurement on flange
<i>Longitudinals - bracket</i>	- Minimum of three at top, middle and bottom of tank in same three bays	5 point pattern over area of bracket
<i>Vertical web and transverse bulkheads of double side tanks (excluding deck area):</i> - Strakes in way of horizontal girders - Other strakes	- Minimum of two webs and both transverse bulkheads - Minimum of two webs and both transverse bulkheads	- 5 point pattern over approx. two square metre area - Two measurements between each pair of vertical stiffeners
<i>Web frames and cross ties for other tanks than double side tanks</i>	Three webs with minimum of three locations on each web, including in way of cross tie connections and lower end bracket	5 point pattern over approximately two square metre area of webs, plus single measurements on flanges of web frame and cross ties
<i>Horizontal girdes</i>	Plating on each girder in a minimum of three bays	Two measurements between each pair of longitudinal girder stiffeners
<i>Panel stiffening</i>	Where applicable	Single measurements

Table IV, Sheet 4
REQUIREMENTS FOR EXTENT OF THICKNESS MEASUREMENTS AT THOSE AREAS
OF SUBSTANTIAL CORROSION
RENEWAL SURVEY OF CHEMICAL TANKERS FOR WHICH ESP REQUIREMENTS APPLY
WITHIN THE CARGO AREA LENGTH

TRANSVERSE BULKHEADS AND SWASH BULKHEADS		
Structural member	Extent measurement	Pattern of measurement
<i>Upper and lower stool, where fitted</i>	Transverse band within 25 mm of welded connection to inner bottom/deck plating Transverse band within 25 mm of welded connection to shelf plate	5 points pattern between stiffeners over one meter length
<i>Deckhead and bottom strakes, and strakes in way of stringer plating</i>	Plating between pair of stiffeners at three locations: approximately 1/4, 1/2 and 3/4 width of tank	5 points pattern between stiffeners over one meter length
<i>All other strakes</i>	Plating between pair of stiffeners at middle location	Single measurement
<i>Strakes in corrugated bulkheads</i>	Plating for each change of scantling at centre of panel and at flange or fabricated connection	5 point pattern over about 1 square metre of plating
<i>Stiffeners</i>	Minimum of three typical stiffeners	For web, 5 point pattern over span between bracket connections (two measurements across web at each bracket connection, and one at centre of span). For flange, single measurements at each bracket toe and at centre of span
<i>Brackets</i>	Minimum of three at top middle and bottom of tank	5 point pattern over areas of bracket
<i>Horizontal stringers</i>	All stringers with measurements at both ends and middle	5 point pattern over one square metre area, plus single measurements near bracket toes and on flanges
<i>Deep webs and girders</i>	Measurements at toe of bracket and at centre of span	For web, 5 point pattern over about 1 square metre. 3 measurements across face flat

ANNEX B

Hull Surveys of Double Hull Oil Tankers

Annex B **HULL SURVEYS OF DOUBLE HULL OIL TANKERS**

Contents:

	Page
1 GENERAL.....	1
1.1 APPLICATION	1
1.2 DEFINITIONS	1
1.3 REPAIRS.....	4
1.4 THICKNESS MEASUREMENTS AND CLOSE-UP SURVEYS.....	4
2 RENEWAL (SPECIAL) SURVEY	5
2.1 SCHEDULE	5
2.2 SCOPE.....	5
2.3 EXTENT OF OVERALL AND CLOSE-UP SURVEYS.....	5
2.4 EXTENT OF THICKNESS MEASUREMENTS.....	6
2.5 EXTENT OF TANK TESTING	6
3 ANNUAL SURVEY	7
3.1 SCHEDULE	7
3.2 SCOPE.....	7
4 INTERMEDIATE SURVEY	8
4.1 SCHEDULE	8
4.2 SCOPE.....	8
5 PREPARATION FOR SURVEY	9
5.1 SURVEY PROGRAMME.....	9
5.2 CONDITIONS FOR SURVEY	9
5.3 ACCESS TO STRUCTURES.....	10
5.4 EQUIPMENT FOR SURVEY.....	10
5.5 RESCUE AND EMERGENCY RESPONSE EQUIPMENT	10
5.6 SURVEY AT SEA OR AT ANCHORAGE	10
5.7 SURVEY PLANNING MEETING	11
6 DOCUMENTATION ON BOARD	13
6.1 GENERAL.....	13
6.2 SURVEY REPORT FILE.....	13
6.3 SUPPORTING DOCUMENTS	13
6.4 REVIEW OF DOCUMENTATION ON BOARD	13
7 PROCEDURES FOR THICKNESS MEASUREMENTS	14
7.1 GENERAL.....	14
7.2 CERTIFICATION OF THICKNESS MEASUREMENTS FIRM.....	14
7.3 NUMBER AND LOCATIONS OF MEASUREMENTS	14
7.4 REPORTING.....	17
8 ACCEPTANCE CRITERIA.....	18
8.1 GENERAL.....	18
8.2 ACCEPTANCE CRITERIA FOR PITTING CORROSION OF CSR SHIPS	18
8.3 ACCEPTANCE CRITERIA FOR EDGE CORROSION OF CSR SHIPS	18
8.4 ACCEPTANCE CRITERIA FOR GROOVING CORROSION OF CSR SHIPS	18
9 REPORTING AND EVALUATION OF SURVEY.....	19
9.1 EVALUATION OF SURVEY REPORT	19
9.2 REPORTING.....	19

1 GENERAL

1.1 APPLICATION

1.1.1 The requirements apply to all self-propelled Double Hull Oil Tankers.

1.1.2 The requirements apply to surveys of hull structure and piping systems in way of cargo tanks, pump rooms, cofferdams, pipe tunnels, void spaces within the cargo area and all ballast tanks. The requirements are additional to the requirements applicable to the remainder of the ship. Refer to subtitles 4.2, 5.2 and 7.2 in the *Rules for the classification of ships, Part 1 - General requirements, Chapter 5 - Surveys of ships in service*.

1.1.3 The requirements contain the minimum extent of examination, thickness measurements and tank testing. The survey is to be extended when Substantial Corrosion and/or structural defects are found and include additional Close-up Survey when necessary.

1.2 DEFINITIONS

1.2.1 Double Hull Oil Tanker

A Double Hull Oil Tanker is a ship which is constructed primarily for the carriage of oil ¹⁾ in bulk, has the cargo tanks forming an integral part of the ship's hull and is protected by a double hull which extends for the entire length of the cargo area, consisting of double sides and double bottom spaces for the carriage of water ballast or void spaces.

1.2.2 Ballast Tank

A Ballast Tank is a tank which is used solely for the carriage of salt water ballast.

A Combined Cargo/Ballast Tank is a tank which is used for the carriage of cargo or ballast water as a routine part of the vessel's operation and will be treated as a Ballast Tank. Cargo tanks in which water ballast might be carried only in exceptional cases per MARPOL 73/78 Annex I/18(3) are to be treated as cargo tanks.

1.2.3 Overall Survey

An Overall Survey is a survey intended to report on the overall condition of the hull structure and determine the extent of additional Close-up Surveys.

1.2.4 Close-up Survey

A Close-up Survey is a survey where the details of structural components are within the close visual inspection range of the Surveyor, i.e. normally within reach of hand.

1.2.5 Transverse Section

A Transverse Section includes all longitudinal members such as plating, longitudinals and girders at the deck, sides, bottom, inner bottom and longitudinal bulkheads. For transversely framed vessels, a transverse section includes

adjacent frames and their end connections in way of transverse sections.

1.2.6 Representative Tank

Representative Tanks are those which are expected to reflect the condition of other tanks of similar type and service and with similar corrosion prevention systems. When selecting Representative Tanks account is to be taken of the service and repair history onboard and identifiable Critical Structural Areas and/or Suspect Areas.

1.2.7 Suspect Area

Suspect Areas are locations showing Substantial Corrosion and/or are considered by the Surveyor to be prone to rapid wastage.

1.2.8 Critical Structural Area

Critical Structural Areas are locations which have been identified from calculations to require monitoring or from the service history of the subject ship or from similar or sister ships (if available) to be sensitive to cracking, buckling or corrosion which would impair the structural integrity of the ship.

1.2.9 Renewal Thickness

Renewal thickness (t_{ren}) is the minimum allowable thickness, in mm, below which renewal of structural members is to be carried out.

1.2.10 Substantial Corrosion

Substantial Corrosion is an extent of corrosion such that assessment of corrosion pattern indicate a wastage in excess of 75% of allowable margins, but within acceptable limits.

For vessels built under the IACS Common Structural Rules, substantial corrosion is an extent of corrosion such that the assessment of the corrosion pattern indicates a gauged (or measured) thickness between $t_{net} + 0.5\text{mm}$ and t_{net} .

1.2.11 Corrosion Prevention System

A Corrosion Prevention System is normally considered a full hard protective coating.

Hard Protective Coating is to usually be epoxy coating or equivalent. Other coating systems which are neither soft nor semi-hard coatings, may be considered acceptable as alternatives provided that they are applied and maintained in compliance with the manufacturer's specification

1.2.12 Coating condition

Coating condition is defined as follows:

GOOD - condition with only minor spot rusting.

FAIR - condition with local breakdown at edges of stiffeners and weld connections and/or light rusting over 20% or more of areas under consideration, but less than as defined for POOR condition.

POOR - condition with general breakdown of coating over 20% or more or hard scale at 10% or more, of areas under consideration.

¹⁾ MARPOL 73/78 Annex I cargoes - requirements in this UR are also applicable to existing double hull tankers not complying with MARPOL 73/78 Regulation 13F, but having a U-shaped midship section.

NOTE: Reference is made to IACS Recommendation No.87 “Guidelines for Coating Maintenance & Repairs for Ballast Tanks and Combined Tanks on Oil Tankers”.

1.2.13 Cargo Area

Cargo Area is that part of the ship which contains cargo tanks, slop tanks and cargo/ballast pumprooms, cofferdams, ballast tanks and void spaces adjacent to cargo tanks and also deck areas throughout the entire length and breadth of the part of the ship over the above mentioned spaces.

1.2.14 Special consideration

Special consideration or specially considered (in connection with close-up surveys and thickness measurements) means sufficient close-up inspection and thickness measurements are to be taken to confirm the actual average condition of the structure under the coating.

1.2.15 Prompt and Thorough Repair

A Prompt and Thorough Repair is a permanent repair completed at the time of survey to the satisfaction of the Surveyor, therein removing the need for the imposition of any associated condition of class.

1.2.16 Pitting Corrosion

Pitting corrosion is defined as scattered corrosion spots/areas with local material reductions which are greater than the general corrosion in the surrounding area. Pitting intensity is defined in Figure 1.

1.2.17 Edge Corrosion

Edge corrosion is defined as local corrosion at the free edges of plates, stiffeners, primary support members and around openings. An example of edge corrosion is shown in Figure 2.

1.2.18 Grooving Corrosion

Grooving corrosion is typically local material loss adjacent to weld joints along abutting stiffeners and at stiffener or plate butts or seams. An example of groove corrosion is shown in Figure 3.

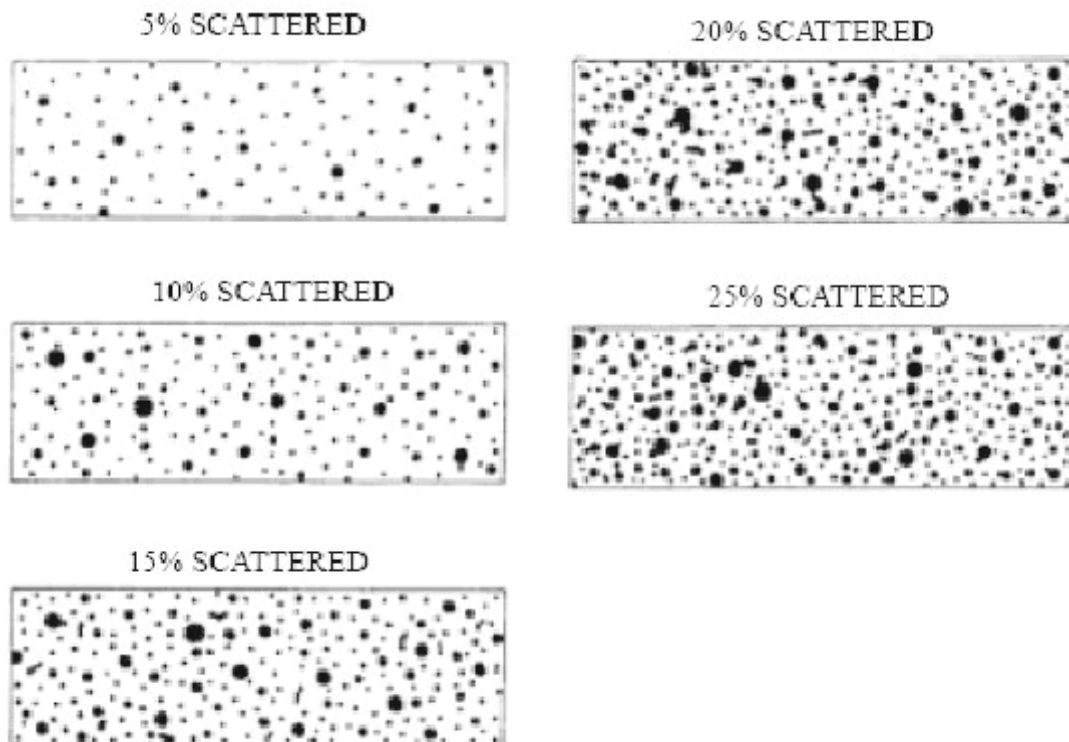

Figure 1 - Pitting intensity diagrams

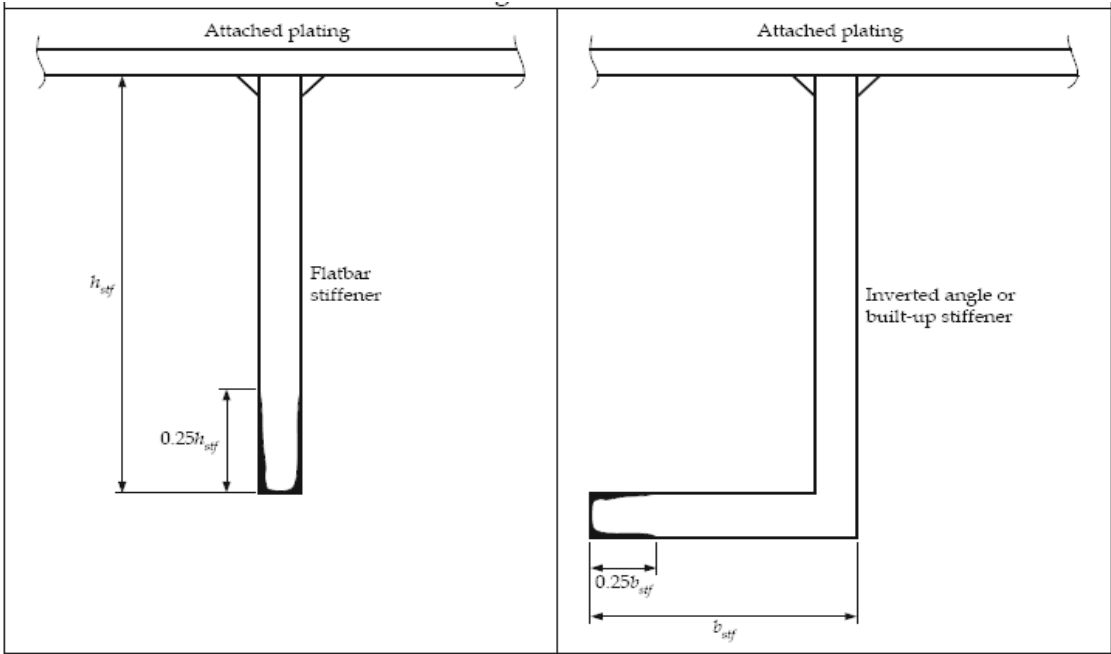

Figure 2 - Edge corrosion

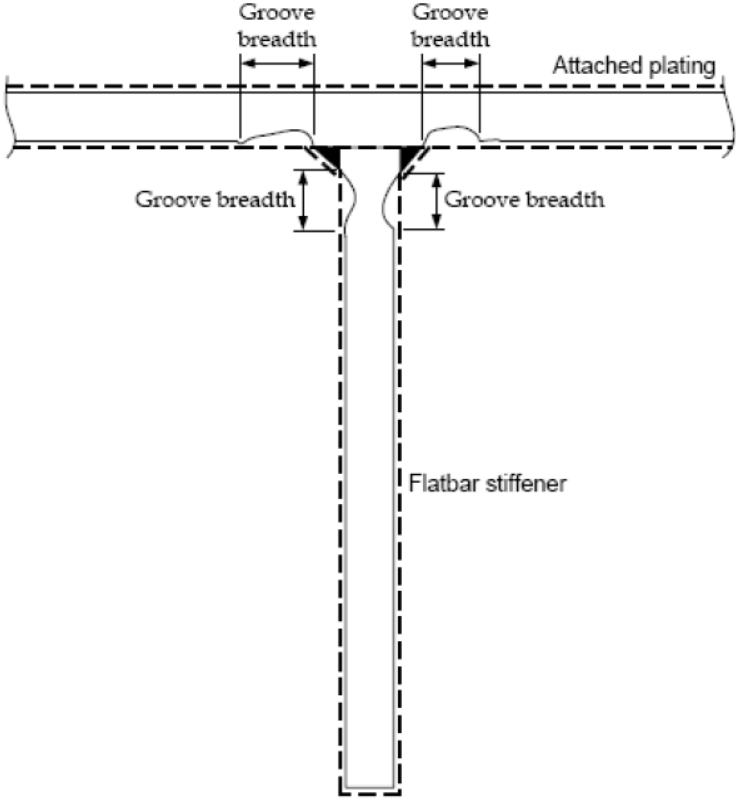

Figure 3 - Grooving corrosion

1.3 REPAIRS

1.3.1 Any damage in association with wastage over the allowable limits (including buckling, grooving, detachment or fracture), or extensive areas of wastage over the allowable limits, which affects or, in the opinion of the Surveyor, will affect the vessel's structural, watertight or weathertight integrity, is to be promptly and thoroughly (see 1.2.14) repaired.

Areas to be considered include:

- bottom structure and bottom plating;
- side structure and side plating;
- deck structure and deck plating;
- watertight or oiltight bulkheads;
- hatch covers or hatch coamings, where fitted (combination carriers).

For locations where adequate repair facilities are not available, consideration may be given to allow the vessel to proceed directly to a repair facility. This may require discharging the cargo and/or temporary repairs for the intended voyage.

1.3.2 Additionally, when a survey results in the identification of structural defects or corrosion, either of which, in the opinion of the Surveyor, will impair the vessel's fitness for continued service, remedial measures are to be implemented before the ship continues in service.

1.3.3 Where the damage found on structure mentioned in para. 1.3.1 is isolated and of a localised nature which does not affect the ship's structural integrity, consideration may be given by the surveyor to allow an appropriate temporary repair to restore watertight or weather tight integrity and impose a condition of class in accordance with IACS PR 35, with a specific time limit.

1.4 THICKNESS MEASUREMENTS AND CLOSE-UP SURVEYS

1.4.1 In any kind of survey, i.e. renewal, intermediate, annual or other surveys having the scope of the foregoing ones, thickness measurements, when required by Table II, of structures in areas where close-up surveys are required shall be carried out simultaneously with close-up surveys.

2 RENEWAL (SPECIAL) SURVEY

2.1 SCHEDULE

2.1.1 Renewal Surveys are to be carried out at 5 years intervals to renew the Certificate of class.

2.1.2 The first Renewal Survey is to be completed within 5 years from the date of the initial survey and thereafter within 5 years from the credited date of the previous Renewal Survey. However, an extension of validity of the Cargo Ship Safety Construction Certificate of 3 months maximum beyond the 5th year can be granted in exceptional circumstances. In this case, the next period of validity of the Cargo Ship Safety Construction Certificate will start from the expiry date of the Renewal Survey before the extension was granted.

2.1.3 For surveys completed within 3 months before the expiry date of the Renewal Survey, the next period of validity of the Cargo Ship Safety Construction Certificate will start from the expiry date of the Renewal Survey. For surveys completed more than 3 months before the expiry date of the Renewal Survey, the period of validity of the Cargo Ship Safety Construction Certificate will start from the survey completion date. In cases where the vessel has been laid up or has been out of service for a considerable period because of a major repair or modification and the owner elects to only carry out the overdue surveys, the next period of class will start from the expiry date of the Renewal survey. If the owner elects to carry out the next due Renewal survey, the period of class will start from the survey completion date.

2.1.4 The Renewal Survey may be commenced at the 4th Annual Survey and be progressed with a view to completion by the 5th anniversary date. When the Renewal survey is commenced prior to the 4th Annual survey, the entire survey is to be completed within 15 months if such work is to be credited to the Renewal survey.

2.1.5 Concurrent crediting to both Intermediate survey and Renewal survey for surveys and thickness measurements of spaces are not acceptable.

2.2 SCOPE

2.2.1 General

2.2.1.1 The Renewal Survey is to include, in addition to the requirements of the Annual Survey, examination, tests and checks of sufficient extent to ensure that the hull and related piping, as required in 2.2.1.3, is in a satisfactory condition and is fit for its intended purpose for the new period of validity of the Cargo Ship Safety Construction Certificate of 5 years to be assigned, subject to proper maintenance and operation and to periodical surveys being carried out at the due dates.

2.2.1.2 All cargo tanks, ballast tanks including double bottom tanks, pumprooms, pipe tunnels, cofferdams and void spaces bounding cargo tanks, decks and outer hull are to be examined, and this examination is to be supplemented by thickness measurement and testing as required in 2.4 and 2.5,

to ensure that the structural integrity remains effective. The aim of the examination is to be sufficient to discover substantial corrosion, significant deformation, fractures, damages or other structural deterioration, that may be present.

2.2.1.3 Cargo piping on deck, including Crude Oil Washing (COW) piping, Cargo and Ballast piping within the above tanks and spaces are to be examined and operationally tested to working pressure to attending Surveyor's satisfaction to ensure that tightness and condition remain satisfactory. Special attention is to be given to any ballast piping in cargo tanks and any cargo piping in ballast tanks and void spaces, and Surveyors are to be advised on all occasions when this piping, including valves and fittings are open during repair periods and can be examined internally.

2.2.2 Dry Dock Survey

2.2.2.1 A survey in dry dock is to be a part of the Renewal Survey. The overall and close-up surveys and thickness measurements, as applicable, of the lower portions of the cargo tanks and ballast tanks are to be carried out in accordance with the applicable requirements for Renewals surveys, if not already performed.

NOTE: Lower portions of the cargo and ballast tanks are considered to be the parts below light ballast water line.

2.2.3 Tank Protection

2.2.3.1 Where provided, the condition of the corrosion prevention system of cargo tanks is to be examined.

A ballast tank is to be examined at subsequent annual intervals where:

- a) a **hard** protective coating has not been applied from the time of construction, or
- b) a soft or semi-hard coating has been applied, or
- c) substantial corrosion is found within the tank, or
- d) the **hard** protective coating is found to be in less than GOOD condition and the **hard** protective coating is not repaired to the satisfaction of the Surveyor.

Thickness measurements are to be carried out as deemed necessary by the Surveyor.

2.3 EXTENT OF OVERALL AND CLOSE-UP SURVEYS

2.3.1 An Overall Survey of all tanks and spaces is to be carried out at each Renewal Survey.

2.3.2 The minimum requirements for Close-up Surveys at Renewal Survey are given in Table I.

2.3.3 The Surveyor may extend the Close-up Survey as deemed necessary taking into account the maintenance of the tanks under survey, the condition of the corrosion prevention system and also in the following cases:

- a) in particular, tanks having structural arrangements or details which have suffered defects in similar tanks or on similar ships according to available information;

- b) in tanks which have structures approved with reduced scantlings due to an approved corrosion control system.

2.3.4 For areas in tanks where hard protective coatings are found to be in a GOOD condition as defined in 1.2.11, the extent of Close-up Surveys according to Table I may be specially considered.

2.4 EXTENT OF THICKNESS MEASUREMENTS

2.4.1 The minimum requirements for thickness measurements at Renewal Survey are given in Table II.

2.4.2 Provisions for extended measurements for areas with Substantial Corrosion, are given in Table IV, and as may be additionally specified in the Survey Programme as required. in 5.1. These extended thickness measurements are to be carried out before the survey is credited as completed. Suspect Areas identified at previous surveys are to be examined. Areas of substantial corrosion identified at previous surveys are to have thickness measurements taken.

For vessels built under IACS Common Structural Rules, the identified substantial corrosion areas are required to be examined and additional thickness measurements are to be carried out at annual and intermediate surveys.

2.4.3 The Surveyor may further extend the thickness measurements as deemed necessary.

2.4.4 For areas in tanks where hard protective coating is found to be in a GOOD condition as defined in 1.2.11, the extent of thickness measurements according to Table II may be specially considered.

2.4.5 Transverse sections are to be chosen where the largest reductions are suspected to occur or are revealed from deck plating measurements.

2.4.6 In cases where two or three sections are to be measured, at least one is to include a Ballast Tank within 0.5L amidships.

NOTE: In case of Oil Tankers of 130 m in length and upwards (as defined in the International Convention on Load Lines in force), and more than 10 years of age, the sampling method of thickness measurements is to be used for longitudinal strength evaluation as required in 9.1.1.1.

2.5 EXTENT OF TANK TESTING

2.5.1 The minimum requirements for ballast tank testing at Renewal Survey are given in 2.5.3 and Table III. The minimum requirements for cargo tank testing at Renewal Survey are given in 2.5.4 and Table III. Cargo tank testing carried out by the vessel's crew under the direction of the Master may be accepted by the surveyor provided the following conditions are complied with:

- a) a tank testing procedure, specifying fill heights, tanks being filled and bulkheads being tested, has been submitted by the owner and reviewed by the *Register* prior to the testing being carried out;
- b) the tank testing is carried out prior to overall survey or close-up survey;
- c) the tank testing is carried out within the

special survey window and not more than three months prior to the date on which the overall or close up survey is completed;

- d) the tank testing has been satisfactorily carried out and there is no record of leakage, distortion or substantial corrosion that would affect the structural integrity of the tank;
- e) the satisfactory results of the testing is recorded in the vessel's logbook; and
- f) the internal and external condition of the tanks and associated structure are found satisfactory by the surveyor at the time of the overall and close up survey.

2.5.2 The Surveyor may extend the tank testing as deemed necessary.

2.5.3 Boundaries of ballast tanks are to be tested with a head of liquid to the top of air pipes.

2.5.4 Boundaries of cargo tanks are to be tested to the highest point that liquid will rise under service conditions.

2.5.5 The testing of double bottom tanks and other spaces not designed for the carriage of liquid may be omitted, provided a satisfactory internal examination together with an examination of the tanktop is carried out.

3 ANNUAL SURVEY

3.1 SCHEDULE

3.1.1 Annual Surveys are to be held within 3 months before or after anniversary date from the date of the initial classification survey or of the date credited for the last Renewal Survey.

3.2 SCOPE

3.2.1 General

3.2.1.1 The survey is to consist of an examination for the purpose of ensuring, as far as practicable, that the hull and piping are maintained in a satisfactory condition and should take into account the service history, condition and extent of the corrosion prevention system of ballast tanks and areas identified in the survey report file.

3.2.2 Examination of the hull

3.2.2.1 Examination of the hull plating and its closing appliances as far as can be seen.

3.2.2.2 Examination of watertight penetrations as far as practicable.

3.2.3 Examination of the weather deck

3.2.3.1 Examination of cargo tank openings including gaskets, covers, coamings and flame screens.

3.2.3.2 Examination of cargo tanks pressure/vacuum valves and flame screens.

3.2.3.3 Examination of flame screens on vents to all bunker tanks.

3.2.3.4 Examination of cargo, crude oil washing, bunker and vent piping systems, including vent masts and headers.

3.2.4 Examination of cargo pump rooms and pipe tunnels if fitted

3.2.4.1 Examination of all pump room bulkheads for signs of oil leakage or fractures and, in particular, the sealing arrangements of all penetrations of pump room bulkheads.

3.2.4.2 Examination of the condition of all piping systems.

3.2.5 Examination of Ballast Tanks

3.2.5.1 Examination of Ballast Tanks where required as a consequence of the results of the Renewal Survey (see 2.2.3) and Intermediate Survey (see 4.2.2.1 and 4.2.2.2) is to be carried out. When considered necessary by the Surveyor, or when extensive corrosion exists, thickness measurements are to be carried out and if the results of these thickness measurements indicate that Substantial Corrosion is found,

the extent of thickness measurements is to be increased in accordance with Table IV. These extended thickness measurements are to be carried out before the survey is credited as completed. Suspect Areas identified at previous surveys are to be examined. Areas of substantial corrosion identified at previous surveys are to have thickness measurements taken.

For vessels built under IACS Common Structural Rules, the identified substantial corrosion areas are required to be examined and additional thickness measurements are to be carried out at annual and intermediate surveys.

4 INTERMEDIATE SURVEY

4.1 SCHEDULE

4.1.1 The Intermediate Survey is to be held at or between either the 2nd or 3rd Annual Survey.

4.1.2 Those items, which are additional to the requirements of the Annual Surveys, may be surveyed either at or between the 2nd and 3rd Annual Survey.

4.1.3 Concurrent crediting to both Intermediate survey and Renewal survey for surveys and thickness measurements of spaces are not acceptable.

4.2 SCOPE

4.2.1 General

4.2.1.1 The survey extent is dependent on the age of the vessel as specified in 4.2.2 to 4.2.4 and shown in Table V.

4.2.1.2 For weather decks, an examination as far as applicable of cargo, crude oil washing, bunker, ballast, steam and vent piping systems as well as vent masts and headers is to be carried out. If upon examination there is any doubt as to the condition of the piping, the piping may be required to be pressure-tested, thickness measured or both.

4.2.1.3 For vessels built under IACS Common Structural Rules, the identified substantial corrosion areas are required to be examined and additional thickness measurements are to be carried out.

4.2.2 Double Hull Oil Tankers between 5 and 10 years of age

The following is to apply:

4.2.2.1 For tanks used for salt-water ballast, an Overall Survey of Representative Tanks selected by the Surveyor is to be carried out.

If such inspections reveal no visible structural defects, the examination may be limited to a verification that the hard protective coating remains in GOOD condition.

4.2.2.2 A Ballast Tank is to be examined at subsequent annual intervals where:

- a) a **hard** protective coating has not been applied from the time of construction, or
- b) a soft or semi-hard coating has been applied, or
- c) substantial corrosion is found within the tank, or
- d) the **hard** protective coating is found to be in less than GOOD condition and the **hard** protective coating is not repaired to the satisfaction of the Surveyor.

4.2.2.3 In addition to the requirements above, suspect areas identified at previous surveys are to be examined.

4.2.3 Double Hull Oil Tankers between 10 and 15 years of age

The following is to apply:

4.2.3.1 The requirements of the Intermediate Survey are to be to the same extent as the previous Renewal Survey as required in 2 and 5.1. However, pressure testing of cargo and ballast tanks and the requirements for longitudinal strength evaluation of Hull Girder as required in 8.1.1.1 are not required unless deemed necessary by the attending Surveyor.

4.2.3.2 In application of 4.2.3.1, the intermediate survey may be commenced at the second annual survey and be progressed during the succeeding year with a view to completion at the third annual survey in lieu of the application of 2.1.4.

4.2.3.3 In application of 4.2.3.1, an underwater survey may be considered in lieu of the requirements of 2.2.2.

4.2.4 Double Hull Oil Tankers over 15 years of age

The following is to apply:

4.2.4.1 The requirements of the Intermediate Survey are to be to the same extent as the previous Renewal Survey as required in 2 and 5.1. However, pressure testing of cargo and ballast tanks and the requirements for longitudinal strength evaluation of Hull Girder as required in 8.1.1.1 are not required unless deemed necessary by the attending Surveyor.

4.2.4.2 In application of 4.2.4.1, the intermediate survey may be commenced at the second annual survey and be progressed during the succeeding year with a view to completion at the third annual survey in lieu of the application of 2.1.4.

4.2.4.3 In application of 4.2.4.1, a survey in dry dock is to be part of the intermediate survey. The overall and close-up surveys and thickness measurements, as applicable, of the lower portions of the cargo tanks and water ballast tanks are to be carried out in accordance with the applicable requirements for intermediate surveys, if not already carried out.

NOTE: Lower portions of the cargo and ballast tanks are considered to be the parts below light ballast water line.

5 PREPARATION FOR SURVEY

5.1 SURVEY PROGRAMME

5.1.1 The Owner in co-operation with the *Register* is to work out a specific Survey

Programme prior to the commencement of any part of:

- the Renewal Survey
- the Intermediate Survey for oil tankers over 10 years of age.

The Survey Programme is to be in a written format. The Survey Programme at Intermediate Survey may consist of the Survey Programme at the previous Renewal Survey supplemented by the Executive Hull Summary of that Renewal Survey and later relevant survey reports.

The Survey Program is to be worked out taking into account any amendments to the survey requirements implemented after the last Renewal Survey carried out.

The Survey Programme is to be in a written format. The survey is not to commence until the survey programme has been agreed.

5.1.1.1 Prior to the development of the survey programme, the survey planning questionnaire is to be completed by the owner, and forwarded to the *Register*.

5.1.2 In developing the Survey Programme, the following documentation is to be collected and consulted with a view to selecting tanks, areas, and structural elements to be examined:

- survey status and basic ship information;
- documentation on-board, as described in 6.2 and 6.3;
- main structural plans (scantlings drawings), including information regarding use of high tensile steels (HTS);
- Executive Hull Summary;
- relevant previous damage and repair history;
- relevant previous survey and inspection reports from both the *Register* and the Owner;
- cargo and ballast history for the last 3 years, including carriage of cargo under heated conditions;
- details of the inert gas plant and tank cleaning procedures;
- information and other relevant data regarding conversion or modification of the ship's cargo and ballast tanks since the time of construction;
- description and history of the coating and corrosion protection system (previous class notation), if any;
- inspections by the Owner's personnel during the last 3 years with reference to structural deterioration in general, leakages in tank boundaries and piping and condition of the coating and corrosion protection system if any. Guidance for re-

porting is shown in Annex IVC.

- information regarding the relevant maintenance level during operation including port state control reports of inspection containing hull related deficiencies, Safety Management System non-conformities relating to hull maintenance, including the associated corrective action(s); and
- any other information that will help identify suspect areas and critical structural areas.

5.1.3 The submitted Survey Programme is to account for and comply, as a minimum, with the requirements of Tables I, II, and 2.5 for close-up survey, thickness measurement and tank testing, respectively, and is to include relevant information including at least:

- basic ship information and particulars;
- main structural plans (scantling drawings), including information regarding use of high tensile steels (HTS);
- plan of tanks;
- list of tanks with information on use, corrosion prevention and condition of coating;
- conditions for survey (e.g., information regarding tank cleaning, gas freeing, ventilation, lighting, etc.);
- provisions and methods for access to structures;
- equipment for surveys;
- nomination of tanks and areas for close-up survey (per 2.3);
- nominations of sections for thickness measurement (per 2.4);
- nomination of tanks for tank testing (per 2.5);
- identification of the thickness measurement firm;
- damage experience related to the ship in question.
- critical structural areas and suspect areas, where relevant.

5.1.4 The *Register* will advise the Owner of the maximum acceptable structural corrosion diminution levels applicable to the vessel.

5.2 CONDITIONS FOR SURVEY

5.2.1 The Owner is to provide the necessary facilities for a safe execution of the survey.

5.2.1.1 In order to enable the attending surveyors to carry out the survey, provisions for proper and safe access are to be agreed between the owner and the *Register* and are to be in accordance with IACS PR 37.

5.2.1.2 Details of the means of access are to be provided in the survey planning questionnaire.

5.2.1.3 In cases where the provisions of safety and required access are judged by the attending surveyors not to be adequate, the survey of the spaces involved is to not proceed.

5.2.2 Tanks and spaces are to be safe for access. Tanks and spaces are to be gas free and properly ventilated. Prior to entering a tank, void or enclosed space, it is to be verified that the atmosphere in that space is free from hazardous gas and contains sufficient oxygen.

5.2.3 In preparation for survey and thickness measurements and to allow for a thorough examination, all spaces are to be cleaned including removal from surfaces of all loose accumulated corrosion scale. Spaces are to be sufficiently clean and free from water, scale, dirt, oil residues etc. to reveal corrosion, deformation, fractures, damages, or other structural deterioration. However, those areas of structure whose renewal has already been decided by the owner need only be cleaned and descaled to the extent necessary to determine the limits of the areas to be renewed.

5.2.4 Sufficient illumination is to be provided to reveal corrosion, deformation, fractures, damages or other structural deterioration.

5.2.5 Where soft or semi-hard coatings have been applied, safe access is to be provided for the Surveyor to verify the effectiveness of the coating and to carry out an assessment of the conditions of internal structures which may include spot removal of the coating. When safe access cannot be provided, the soft or semi-hard coating is to be removed.

5.3 ACCESS TO STRUCTURES

5.3.1 For overall survey, means are to be provided to enable the Surveyor to examine the hull structure in a safe and practical way.

5.3.2 For close-up survey, one or more of the following means for access, acceptable to the Surveyor, is to be provided:

- permanent staging and passages through structures;
- temporary staging and passages through structures;
- hydraulic arm vehicles such as conventional cherry pickers, lifts and movable platforms;
- boats or rafts;
- other equivalent means.

5.4 EQUIPMENT FOR SURVEY

5.4.1 Thickness measurement is normally to be carried out by means of ultrasonic test equipment. The accuracy of the equipment is to be proven to the Surveyor as required.

5.4.2 One or more of the following fracture detection procedures may be required if deemed necessary by the Surveyor:

- radiographic equipment;
- ultrasonic equipment;
- magnetic particle equipment;
- dye penetrant.

5.4.3 Explosimeter, oxygen-meter, breathing apparatus, lifelines, riding belts with rope and hook and whistles together with instructions and guidance on their use are to be made available during the survey. A safety check-list is to be provided.

5.4.4 Adequate and safe lighting is to be provided for the safe and efficient conduct of the survey.

5.4.5 Adequate protective clothing is to be made available and used during the survey (e.g. safety helmet, gloves, safety shoes, etc.).

5.5 RESCUE AND EMERGENCY RESPONSE EQUIPMENT

5.5.1 If breathing apparatus and/or other equipment is used as “Rescue and emergency response equipment” then it is recommended that the equipment should be suitable for the configuration of the space being surveyed.

5.6 SURVEY AT SEA OR AT ANCHORAGE

5.6.1 Survey at sea or at anchorage may be accepted provided the Surveyor is given the necessary assistance from the personnel onboard. Necessary precautions and procedures for carrying out the survey are to be in accordance with 5.1, 5.2, 5.3 and 5.4.

5.6.2 A communication system is to be arranged between the survey party in the tank and the responsible officer on deck. This system is to include the personnel in charge of ballast pump handling if boats or rafts are used.

5.6.3 Surveys of tanks by means of boats or rafts may only be undertaken at the sole discretion of the Surveyor, who is to take into account the safety arrangements provided, including weather forecasting and ship response under foreseeable conditions and provided the expected rise of water within the tank does not exceed 0.25m.

5.6.4 When rafts or boats are used for close-up surveys, the following conditions are to be observed:

- .1 only rough duty, inflatable rafts or boats, having satisfactory residual buoyancy and stability even if one chamber is ruptured, should be used;
- .2 the boat or raft should be tethered to the access ladder and an additional person should be stationed down the access ladder with a clear view of the boat or raft;
- .3 appropriate lifejackets should be available for all participants;
- .4 the surface of water in the tank should be calm (under all foreseeable conditions the expected rise of water within the tank should not exceed 0.25 m) and the water level either stationary. On no account should the level of the water be rising while the boat or raft is in use;
- .5 the tank or space must contain clean ballast water only. Even a thin sheen of oil on the water is not acceptable;
- .6 at no time should the water level be allowed to be within 1 m of the deepest under deck web face flat so that the survey team is not isolated from a direct escape route to the tank hatch. Filling to levels above the deck transverses should only be contemplated if a deck access manhole is

fitted and open in the bay being examined, so that an escape route for the survey party is available at all times. Other effective means of escape to the deck may be considered;

- .7 if the tanks (or spaces) are connected by a common venting system, or inert gas system, the tank in which the boat or raft should be used should be isolated to prevent a transfer of gas from other tanks (or spaces).

5.6.5 Rafts or boats alone may be allowed for inspection of the under deck areas for tanks or spaces, if the depth of the webs is 1.5 m or less.

5.6.6 If the depth of the webs is more than 1.5 m, rafts or boats alone may be allowed only:

- .1 when the coating of the under deck structure is in GOOD condition and there is no evidence of wastage; or

- .2 if a permanent means of access is provided in each bay to allow safe entry and exit.

This means:

- i. access direct from the deck via a vertical ladder and a small platform fitted approximately 2 m below the deck in each bay; or
- ii. access to deck from a longitudinal permanent platform having ladders to deck in each end of the tank. The platform shall, for the full length of the tank, be arranged in level with, or above, the maximum water level needed for rafting of under deck structure. For this purpose, the ullage corresponding to the maximum water level is to be assumed not more than 3m from the deck plate measured at the midspan of deck transverses and in the middle length of the tank (see Figure 4).

If neither of the above conditions are met, then staging or an “other equivalent means” is to be provided for the survey of the under deck areas.

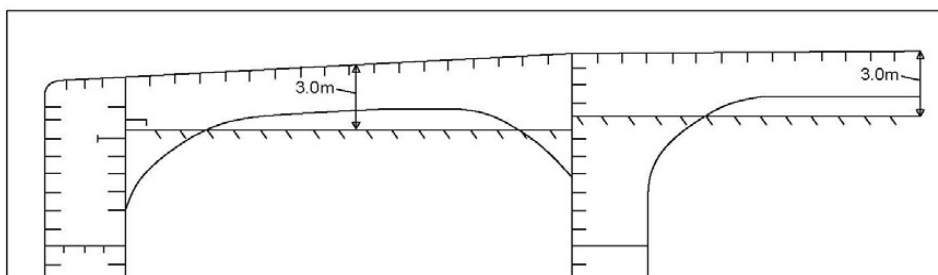

Figure 4 Maximum water level in a tank

5.6.7 The use of rafts or boats alone in paragraphs 5.6.5 and 5.6.6 does not preclude the use of boats or rafts to move about within a tank during a survey.

NOTE: Reference is made to IACS Recommendation 39 – Guidelines for use of Boats or Rafts for Close-up Surveys.

5.7 SURVEY PLANNING MEETING

5.7.1 Proper preparation and close co-operation between the attending surveyor(s) and the owner’s representatives onboard prior to and during the survey are an essential part in the safe and efficient conduct of the survey. During the survey on board safety meetings are to be held regularly.

5.7.2 Prior to the commencement of any part of the Renewal and Intermediate Survey a survey planning meeting is to be held between the attending Surveyor(s), the Owner’s Representative in attendance and the TM firm representative, where involved, and the master of the ship or an appropriately qualified representative appointed by the master or Com-

pany for the purpose to ascertain that all the arrangements envisaged in the survey programme are in place, so as to ensure the safe and efficient conduct of the survey work to be carried out. See also 7.1.2.

5.7.3 The following is an indicative list of items that are to be addressed in the meeting:

- .1 schedule of the vessel (i.e. the voyage, docking and undocking manoeuvres, periods alongside, cargo and ballast operations etc.);
- .2 provisions and arrangements for thickness measurements (i.e. access, cleaning/descaling, illumination, ventilation, personal safety);
- .3 extent of the thickness measurements;
- .4 acceptance criteria (refer to the list of minimum thicknesses);
- .5 extent of close-up survey and thickness measurement considering the coating condition and suspect areas/areas of sub-

- stantial corrosion;
- .6 execution of thickness measurements;
- .7 taking representative readings in general and where uneven corrosion/pitting is found;
- .8 mapping of areas of substantial corrosion; and
- .9 communication between attending surveyor(s) the thickness measurement firm operator(s) and owner representative(s) concerning findings.

6 DOCUMENTATION ON BOARD

6.1 GENERAL

6.1.1 The owner is to supply and maintain on board documentation as specified in 6.2 and 6.3, which is to be readily available for the Surveyor.

6.1.2 The documentation is to be kept on board for the lifetime of the ship.

6.1.3 For ships defined in the *Rules for the classification of ships, Part - General requirements, Chapter 2 - Survey during construction and initial survey*, note in item 1.2.2.27, the following is to be applied to surveys commenced on or after 1st July 2016:

For tankers and bulk carriers subject to SOLAS, Chapter II-1, Part A-1, Regulation 3-10, the Owner is to arrange the updating of the Ship Construction File (SCF) throughout the ship's life whenever a modification of the documentation included in the SCF has taken place. Documented procedures for updating the SCF are to be included within the Safety Management System.

6.2 SURVEY REPORT FILE

6.2.1 A Survey Report File is to be a part of the documentation on board consisting of:

- reports of structural surveys;
- Executive Hull Summary;
- thickness measurement reports.

6.2.2 The Survey Report File is to be available also in the Owner's and the *Register's* management offices.

6.3 SUPPORTING DOCUMENTS

6.3.1 The following additional documentation is to be available onboard:

- Survey Programme as required by 5.1 until such time as the Renewal Survey or Intermediate Survey, as applicable, has been completed;
- main structural plans of cargo and ballast tanks (for CSR ships these plans are to include for each structural element both the as-built and renewal thickness. Any thickness for voluntary addition is also to be clearly indicated on the plans. The midship section plan to be supplied on board the ship is to include the minimum allowable hull girder sectional properties for hold transverse section in all cargo tanks);
- previous repair history;
- cargo and ballast history;
- extent of use of inert gas plant and tank cleaning procedures;
- inspections by ship's personnel with reference to:
 - structural deterioration in general;
 - leakage in bulkheads and piping;

- condition of coating or corrosion prevention system, if any;
- any other information that will help identify Suspect Areas requiring inspection.

6.3.2 For tankers and bulk carriers subject to SOLAS, Chapter II-1, Part A-1, Regulation 3-10, the Ship Construction File (SCF), limited to the items to be retained on board, is to be available on board.

6.4 REVIEW OF DOCUMENTATION ON BOARD

6.4.1 Prior to inspection, the Surveyor is to examine the completeness of the documentation onboard, and its contents as a basis for the survey.

6.4.2 For tankers and bulk carriers subject to SOLAS, Chapter II-1, Part A-1, Regulation 3-10, on completion of the survey, the surveyor is to verify that the update of the Ship Construction File (SCF) has been done whenever a modification of the documentation included in the SCF has taken place.

6.4.2.1 For the SCF stored on board ship, the surveyor is to examine the information on board ship. In cases where any major event, including, but not limited to, substantial repair and conversion, or any modification to the ship structures, the surveyor is to also verify that the updated information is kept on board the ship. If the updating of the SCF onboard is not completed at the time of survey, the Surveyor records it and requires confirmation at the next periodical survey.

6.4.2.2 For the SCF stored on shore archive, the surveyor is to examine the list of information included on shore archive. In cases where any major event, including, but not limited to, substantial repair and conversion, or any modification to the ship structures, the surveyor is to also verify that the updated information is stored on shore archive by examining the list of information included on shore archive or kept on board the ship. In addition, the surveyor is to confirm that the service contract with of the Archive Center is valid. If the updating of the SCF Supplement ashore is not completed at the time of survey, the Surveyor records it and requires confirmation at the next periodical survey.

6.4.3 For tankers and bulk carriers subject to SOLAS, Chapter II-1, Part A-1, Regulation 3-10, on completion of the survey, the surveyor is to verify any addition and/or renewal of materials used for the construction of the hull structure are documented within the Ship Construction File inventory list.

7 PROCEDURES FOR THICKNESS MEASUREMENTS

7.1 GENERAL

7.1.1 Thickness measurements required, if not carried out by the *Register* itself, are to be witnessed by a Surveyor on board to the extent necessary to control the process.

7.1.2 The thickness measurement firm is to be part of the survey planning meeting to be held prior to commencing the survey.

7.1.3 Thickness measurements of structures in areas where close-up surveys are required shall be carried out simultaneously with close-up surveys.

7.1.4 In all cases the extent of the thickness measurements is to be sufficient as to represent the actual average condition.

7.2 CERTIFICATION OF THICKNESS MEASUREMENTS FIRM

7.2.1 The thickness measurements are to be carried out by a qualified firm certified by the *Register* according to principles stated in the *Rules, Part 1 - General requirements, Chapter 4 - Approval of manufacturers and service suppliers*.

7.3 NUMBER AND LOCATIONS OF MEASUREMENTS

7.3.1 Application

The item 7.3 only applies to vessels built under the IACS Common Structural Rules*. For vessels not built under IACS Common Structural Rules, the requirements for number and locations of measurements are according to the Rules of the *Register* and/or specific IACS URs depending on ship's age and structural elements concerned.

* IACS Common Structural Rules mean IACS Common Structural Rules for Double Hull Oil Tankers (IACS CSR for Oil Tankers) or IACS Common Structural Rules for Bulk Carriers and Oil Tankers (IACS CSR BC&OT).

7.3.2 Number of measurements

Considering the extent of thickness measurements according to the different structural elements of the ship and surveys (Renewal, intermediate and annual), the locations of the points to be measured are given for the most important items of the structure.

7.3.3 Locations of measurements

Table 1 provides explanations and/or interpretations for the application of those requirements indicated in the Rules, which refer to both systematic thickness measurements related to the calculation of global hull girder strength and specific measurements connected to close-up surveys.

Fig. 5 to Fig. 8 are provided to facilitate the explanations and/or interpretations given in Table 1, to show typical arrangements of single side skin bulk carriers.

Table 1
INTERPRETATIONS OF RULE REQUIREMENTS FOR THE LOCATIONS AND NUMBER OF POINTS TO BE MEASURED

Item	Interpretation	Figure reference
Selected plates	«Selected» means at least a single point on one out of three plates, to be chosen on representative areas of average corrosion.	
Deck, bottom plates and wind-and-water strakes	At least two points on each plate to be taken either at each 1/4 extremity of plate or at representative areas of average corrosion.	
Transverse section	Measurements to be taken on all longitudinal members such as plating, longitudinals and girders at the deck, side, bottom, longitudinal bulkheads, inner bottom and hopper. One point to be taken on each plate. Both web and flange to be measured on longitudinals, if applicable. For tankers older than 10 years of age: within 0.1D (where D is the ship's moulded depth) of the deck and bottom at each transverse section to be measured, every longitudinal and girder is to be measured on the web and face plate, and every plate is to be measured at one point between longitudinals.	Fig 5

Item	Interpretation	Figure reference
Transverse rings (*) in cargo and ballast tanks	<p>At least two points on each plate in a staggered pattern and two points on the corresponding flange where applicable.</p> <p>Minimum 4 points on the first plate below deck. Additional points in way of curved parts. At least one point on each of two stiffeners between stringers / longitudinal girders.</p>	Fig 6
Transverse bulkheads in cargo tanks	<p>At least two points on each plate. Minimum 4 points on the first plate below main deck.</p> <p>At least one point on every third stiffener to be taken between each stringer.</p> <p>At least two points on each plate of stringers and girders, and two points on the corresponding flange. Additional points in way of curved part.</p> <p>Two points of each diaphragm plate of stools if fitted.</p>	Fig 7
Transverse bulkheads in ballast tanks	<p>At least 4 points on plates between stringers / longitudinal girders, or per plate if stringers / girders not fitted.</p> <p>At least two points on each plate of stringers and girders, and two points on the corresponding flange. Additional points in way of curved part.</p> <p>At least one point on two stiffeners between each stringer / longitudinal girder.</p>	Fig 8
Adjacent structural members	On adjacent structural members one point per plate and one point on every third stiffener / longitudinal.	

(*) Transverse rings means all transverse material appearing in a cross-section of the ship's hull, in way of a double bottom floor, vertical web and deck transverse (definition from CSR)

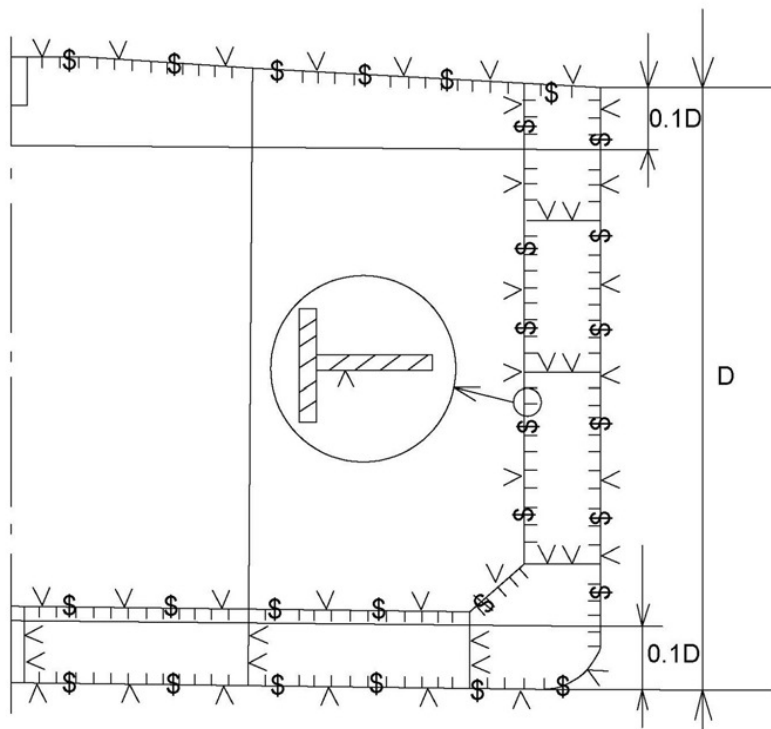

Figure 5 - Transverse section

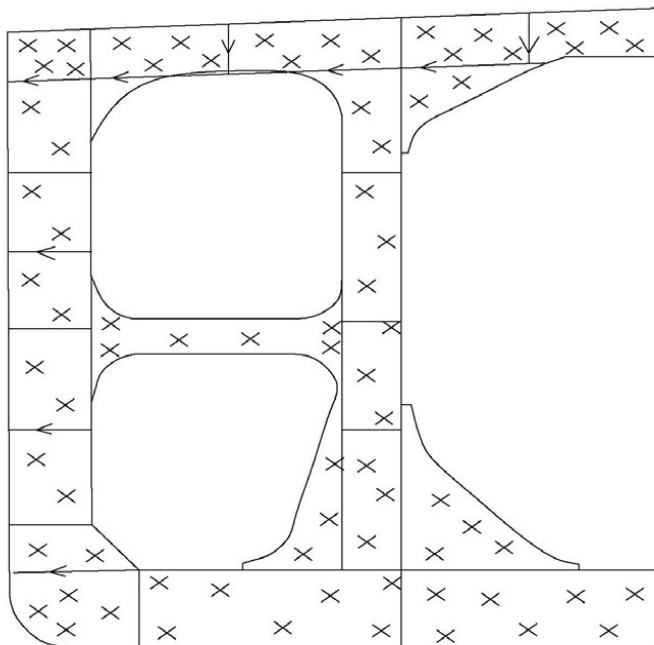

Figure 6 - Transverse rings in cargo and ballast tanks

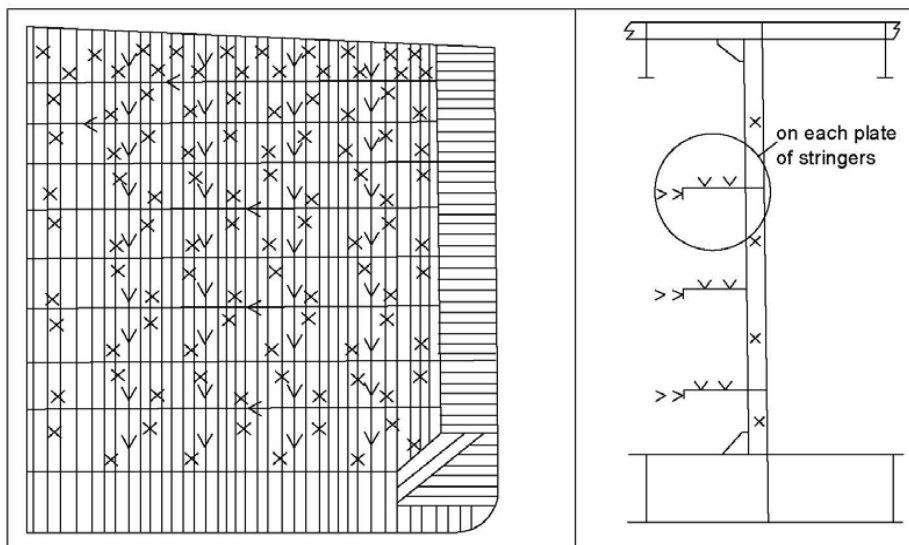

Figure 7 - Transverse bulkheads in cargo tanks

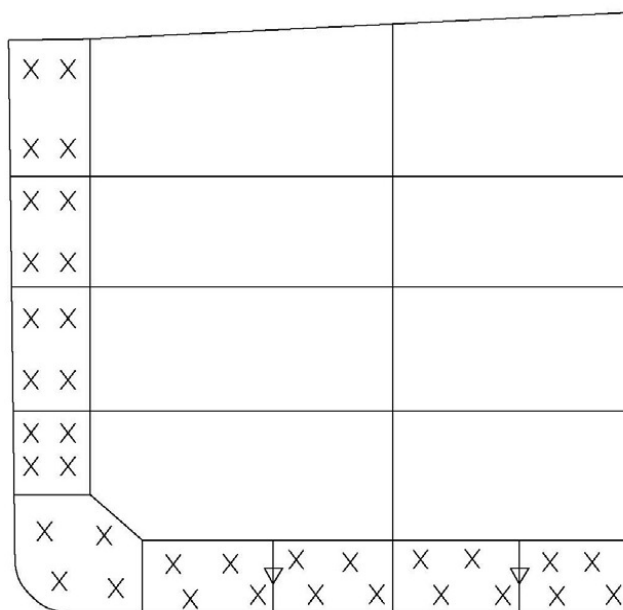

Figure 8 - Transverse bulkheads in ballast tanks

7.4 REPORTING

7.4.1 A thickness measurement report is to be prepared. The report is to give the location of measurements, the thickness measured as well as corresponding original thickness. Furthermore, the report is to give the date when the measurements was carried out, type of measuring equipment,

names of personnel and their qualifications and has to be signed by the operator.

7.4.2 The Surveyor is to verify and countersign the thickness measurement report. The Surveyor is to review the final thickness measurement report and countersign the cover page.

8 ACCEPTANCE CRITERIA

8.1 GENERAL

8.1.1 For vessels built under IACS Common Structural Rules (CSR), the Acceptance Criteria is according to Section 12 - Ship in Operation Renewal Criteria of IACS Common Structural Rules * (CSR) and as specified in 8.2, 8.3 and 8.4.

* Section 12 of IACS CSR for Oil Tankers, or Ch. 13, Part 1 of IACS CSR BC & OT

8.1.2 For vessels not built under IACS Common Structural Rules (CSR), the Acceptance Criteria are according to the Rules of the *Register* and/or specific IACS URs depending on ship's age and structural elements concerned.

8.2 ACCEPTANCE CRITERIA FOR PITTING CORROSION OF CSR SHIPS

8.2.1 For plates with pitting intensity less than 20%, see Figure 1, the measured thickness, t_m , of any individual measurement is to meet the lesser of the following criteria:

$$t_m \geq 0.7 (t_{as-built} - t_{vol\ add}) \text{ mm}$$

$$t_m \geq t_{ren} - 1 \text{ mm}$$

where:

$t_{as-built}$ As-built thickness of the member, in mm

$t_{vol\ add}$ Voluntary thickness addition; thickness, in mm, voluntarily added as the Owner's extra margin for corrosion wastage in addition to t_c

t_{ren} renewal criteria for general corrosion as defined in IACS Common Structural Rules* (CSR)

* 1.4.2.1 of Section 12 of IACS CSR for Oil Tankers, or 2.1.1 of Sec. 2, Ch. 13, Part 1 of IACS CSR BC & OT

8.2.2 The average thickness across any cross section in the plating is not to be less than the renewal criteria for general corrosion given in IACS Common Structural Rules * (CSR).

* 1.4.2.1 of Section 12 of IACS CSR for Oil Tankers, or 2.1.1 of Sec. 2, Ch. 13, Part 1 of IACS CSR BC & OT

8.3 ACCEPTANCE CRITERIA FOR EDGE CORROSION OF CSR SHIPS

8.3.1 Provided that the overall corroded height of the edge corrosion of the flange, or web in the case of flat bar stiffeners, is less than 25%, see Figure 2, of the stiffener flange breadth or web height, as applicable, the measured thickness, t_m , is to meet the lesser of the following criteria:

$$t_m \geq 0.7 (t_{as-built} - t_{vol\ add}) \text{ mm}$$

$$t_m \geq t_{ren} - 1 \text{ mm}$$

where:

$t_{as-built}$ as-built thickness of the member, in mm

$t_{vol\ add}$ voluntary thickness addition; thickness, in mm, voluntarily added as the Owner's extra margin for corrosion wastage in addition to t_c

t_{ren} renewal criteria for general corrosion as defined in IACS Common Structural Rules * (CSR).

* 1.4.2.1 of Section 12 of IACS CSR for Oil Tankers, or 2.1.1 of Sec. 2, Ch. 13, Part 1 of IACS CSR BC & OT

8.3.2 The average measured thickness across the breadth or height of the stiffener is not to be less than that defined in IACS CSR*.

* 1.4.2 of Section 12 of IACS CSR for Oil Tankers, or 2.1 of Sec. 2, Ch. 13, Part 1 of IACS CSR BC & OT

8.3.3 Plate edges at openings for manholes, lightening holes etc. may be below the minimum thickness given in IACS CSR*:

- the maximum extent of the reduced plate thickness, below the minimum given in IACS CSR*, from the opening edge is not more than 20% of the smallest dimension of the opening and does not exceed 100mm.
- rough or uneven edges may be cropped-back provided that the maximum dimension of the opening is not increased by more than 10% and the remaining thickness of the new edge is not less than $t_{ren} - 1$ mm.

* 1.4.2 of Section 12 of IACS CSR for Oil Tankers, or 2.1 of Sec. 2, Ch. 13, Part 1 of IACS CSR BC & OT

8.4 ACCEPTANCE CRITERIA FOR GROOVING CORROSION OF CSR SHIPS

8.4.1 Where the groove breadth is a maximum of 15% of the web height, but not more than 30mm, see Figure 3, the measured thickness, t_m , in the grooved area is to meet the lesser of the following criteria:

$$t_m \geq 0.75 (t_{as-built} - t_{vol\ add}) \text{ mm}$$

$$t_m \geq t_{ren} - 0.5 \text{ mm}$$

but is not to be less than:

$$t_m = 6 \text{ mm}$$

where:

$t_{as-built}$ as-built thickness of the member, in mm

$t_{vol\ add}$ voluntary thickness addition; thickness, in mm, voluntarily added as the Owner's extra margin for corrosion wastage in addition to t_c

t_{ren} renewal criteria for general corrosion as defined in IACS CSR*.

8.4.2 Structural members with areas of grooving greater than those in 8.4.1 above are to be assessed based on the criteria for general corrosion as defined in IACS CSR * using the average measured thickness across the plating/stiffener.

* 1.4.2 of Section 12 of IACS CSR for Oil Tankers, or 2.1 of Sec. 2, Ch. 13, Part 1 of IACS CSR BC & OT

9 REPORTING AND EVALUATION OF SURVEY

9.1 EVALUATION OF SURVEY REPORT

9.1.1 The data and information on the structural condition of the vessel collected during the survey is to be evaluated for acceptability and continued structural integrity of the vessel.

9.1.1.1 In case of oil tankers of 130 m in length and upwards (as defined in the International Convention on Load Lines in force), the ship's longitudinal strength is to be evaluated by using the thickness of structural members measured, renewed and reinforced, as appropriate, during the Renewal survey carried out after the ship reached 10 years of age in accordance with the criteria for longitudinal strength of the ship's hull girder for oil tankers specified in Annex III of IACS UR Z10.4 and in the *Rules for the classification of ships, Part 2 – Hull, Annex B*.

9.1.1.2 The final result of evaluation of the ship's longitudinal strength required in 8.1.1.1, after renewal or reinforcement work of structural members, if carried out as a result of initial evaluation, is to be reported as a part of the Executive Hull Summary.

9.2 REPORTING

9.2.1 Principles for survey reporting are shown in the Annex II of IACS UR Z10.4.

9.2.2 When a survey is split between different survey stations, a report is to be made for each portion of the survey. A list of items examined and / or tested (pressure testing, thickness measurements etc.) and an indication of whether the item has been credited, are to be made available to the next attending Surveyor(s), prior to continuing or completing the survey.

9.2.3 An Executive Hull Summary of the survey and results is to be issued to the Owner and placed on board the vessel for reference at future surveys. The Executive Hull Summary is to be endorsed by the Head Office of the *Register*.

Table I
MINIMUM REQUIREMENTS FOR CLOSE-UP SURVEY AT RENEWAL SURVEY OF DOUBLE HULL OIL TANKERS

I Renewal Survey age ≤ 5	II Renewal Survey 5 < age ≤ 10	III Renewal Survey 10 < age ≤ 15	IV Renewal Survey and Subsequent age > 15
One web frame (1), in a ballast tank (see Note 1)	All web frames (1), in a ballast tank (see Note 1) The knuckle area and the upper part (5 metres approximately) of one web frame in each remaining ballast tank (6)	All web frames (1), in all ballast tanks	As for Renewal Survey for age from 10 to 15 years Additional transverse areas as deemed necessary by the Register
One deck transverse, in a cargo oil tank (2)	One deck transverse, in two cargo oil tanks (2)	All web frames (7), including deck transverse and cross ties, if fitted, in a cargo oil tank One web frame (7), including deck transverse and cross ties, if fitted, in each remaining cargo oil tank	
One transverse bulkhead (4), in a ballast tank (see Note 1)	One transverse bulkhead (4), in each ballast tank (see Note 1)	All transverse bulkheads, in all cargo oil (3) and ballast (4) tanks	
One transverse bulkhead (5) in a cargo oil centre tank One transverse bulkhead (5), in a cargo oil wing tank (see Note 2)	One transverse bulkhead (5), in two cargo oil centre tanks One transverse bulkhead (5), in a cargo oil wing tank (see Note 2)		

(1), (2), (3), (4), (5), (6) and (7) are areas to be subjected to close-up surveys and thickness measurements (see figures in Annex D)
(1): Web frame in a ballast tank means vertical web in side tank, hopper web in hopper tank, floor in double bottom tank and deck transverse in double deck tank (where fitted), including adjacent structural members. In fore and aft peak tanks web frame means a complete transverse web frame ring including adjacent structural members

(2): Deck transverse, including adjacent deck structural members (or external structure on deck in way of the tank, where applicable)

(3): Transverse bulkhead complete in cargo tanks, including girder system, adjacent structural members (such as longitudinal bulkheads) and internal structure of lower and upper stools, where fitted

(4): Transverse bulkhead complete in ballast tanks, including girder system and adjacent structural members, such as longitudinal bulkheads, girders in double bottom tanks, inner bottom plating, hopper side, connecting brackets

(5): Transverse bulkhead lower part in cargo tank, including girder system, adjacent structural members (such as longitudinal bulkheads) and internal structure of lower stool, where fitted

(6): The *knuckle area* and the upper part (5 metres approximately), including adjacent structural members. *Knuckle area* is the area of the web frame around the connections of the slope hopper plating to the inner hull bulkhead and the inner bottom plating, up to 2 metres from the corners both on the bulkhead and the double bottom

(7): Web frame in a cargo oil tank means deck transverse, longitudinal bulkhead vertical girder and cross ties, where fitted, including adjacent structural members

NOTE 1: Ballast tank: Apart from the fore and aft peak tanks, the term "ballast tank" has the following meaning:

- .1 all ballast compartments (hopper tank, side tank and double-deck tank, if separate from double-bottom tank) located on one side, i.e. portside or starboard side, and additionally double-bottom tank on portside plus starboard side, when the longitudinal central girder is not watertight and, therefore, the double bottom tank is a unique compartment from portside to starboard side; or
- .2 all ballast compartments (double-bottom tank, hopper tank, side tank and double-deck tank) located on one side, i.e. portside or starboard side, when the longitudinal central girder is watertight and, therefore, the portside double-bottom tank separate from the starboard-side double-bottom tank.

NOTE 2: Where no centre cargo tanks are fitted (as in the case of centre longitudinal bulkhead), transverse bulkheads in wing tanks are to be surveyed.

Table II
MINIMUM REQUIREMENTS TO THICKNESS MEASUREMENTS AT RENEWAL SURVEY OF DOUBLE HULL OIL TANKERS

I Renewal Survey age ≤ 5	II Renewal Survey 5 < age ≤ 10	III Renewal Survey 10 < age ≤ 15	IV Renewal Survey and Subsequent age > 15
1. Suspect areas	1. Suspect areas	1. Suspect areas	1. Suspect areas
	2. Within the cargo area: - each deck plate - one transverse section	2. Within the cargo area: - each deck plate - two transverse sections (1) - all wind and water strakes	2. Within the cargo area: - each deck plate - three transverse sections (1) - each bottom plate
	3. Selected wind and water strakes outside the cargo area	3. Selected wind and water strakes outside the cargo area	3. All wind and water strakes, full length
	4. Measurements for general assessment and recording of corrosion pattern, of those structural members subject to close-up survey according to Table I.	4. Measurements for general assessment and recording of corrosion pattern, of those structural members subject to close-up survey according to Table I.	4. Measurements for general assessment and recording of corrosion pattern, of those structural members subject to close-up survey according to Table I.
(1): at least one section is to include a ballast tank within 0,5 L amidships.			

Table III
MINIMUM REQUIREMENTS FOR TANK TESTING AT RENEWAL SURVEY OF DOUBLE HULL OIL TANKERS

Age of ship (in years at time of renewal survey due date)	
I Renewal Survey age ≤ 5	II Renewal Survey and Subsequent age > 5
All ballast tank boundaries	All ballast tank boundaries
Cargo tank boundaries facing ballast tanks, void spaces, pipe tunnels, pump rooms or cofferdams	All cargo tank boundaries

Table IV, Sheet 1
REQUIREMENTS FOR EXTENT OF THICKNESS MEASUREMENTS AT THOSE AREAS OF SUBSTANTIAL CORROSION - RENEWAL SURVEY OF DOUBLE HULL OIL TANKERS WITHIN THE CARGO AREA LENGTH

BOTTOM, INNER BOTTOM AND HOPPER STRUCTURE		
Structural member	Extent of measurement	Pattern of measurement
<i>Bottom, inner bottom and hopper structure plating</i>	Minimum of three bays across double bottom tank, including aft bay Measurements around and under all suction bell mouths	5-point pattern for each panel between longitudinals and floors
<i>Bottom, inner bottom and hopper structure longitudinals</i>	Minimum of three longitudinals in each bay where bottom plating measured	Three measurements in line across flange and three measurements on vertical web
<i>Bottom girders, including the watertight ones</i>	At fore and aft watertight floors and in centre of tanks	Vertical line of single measurements on girder plating with one measurement between each panel stiffener, or a minimum of three measurements

BOTTOM, INNER BOTTOM AND HOPPER STRUCTURE		
Structural member	Extent of measurement	Pattern of measurement
<i>Bottom floors, including the watertight ones</i>	Three floors in bays where bottom plating measured, with measurements at both ends and middle	5-point pattern over two square metre area
<i>Hopper structure web frame ring</i>	Three floors in bays where bottom plating measured	5-point pattern over one square metre of plating. Single measurements on flange
<i>Hopper structure transverse watertight bulkhead or swash bulkhead</i>	- lower 1/3 of bulkhead	5-point pattern over one square metre of plating
	- upper 2/3 of bulkhead	5-point pattern over two square metre of plating
	- stiffeners (minimum of three)	For web, 5-point pattern over span (two measurements across web at each end and one at centre of span). For flange, single measurements at each end and centre of span
<i>Panel stiffening</i>	Where applicable	Single measurements

Table IV, Sheet 2

REQUIREMENTS FOR EXTENT OF THICKNESS MEASUREMENTS AT THOSE AREAS OF SUBSTANTIAL CORROSION - RENEWAL SURVEY OF DOUBLE HULL OIL TANKERS WITHIN THE CARGO AREA LENGTH

DECK STRUCTURE		
Structural member	Extent of measurement	Pattern of measurement
<i>Deck plating</i>	Two transverse bands across tank	Minimum of three measurements per plate per band
<i>Deck longitudinals</i>	Every third longitudinal in each of two bands with a minimum of one longitudinal	Three measurements in line vertically on webs and two measurements on flange (if fitted)
<i>Deck girders and brackets (usually in cargo tanks only)</i>	At fore and aft transverse bulkhead, bracket toes and in centre of tanks	Vertical line of single measurements on web plating with one measurement between each panel stiffener, or a minimum of three measurements. Two measurements across flange. 5-point pattern on girder/bulkhead brackets
<i>Deck transverse webs</i>	Minimum of two webs, with measurements at both ends and middle of span	5-point pattern over one square metre area. Single measurements on flange
<i>Vertical web and transverse bulkhead in wing ballast tank (two metres from deck)</i>	Minimum of two webs, and both transverse bulkheads	5-point pattern over one square metre area
<i>Panel stiffening</i>	Where applicable	Single measurements

Table IV, Sheet 3
REQUIREMENTS FOR EXTENT OF THICKNESS MEASUREMENTS AT THOSE AREAS OF SUBSTANTIAL CORROSION - RENEWAL SURVEY OF DOUBLE HULL OIL TANKERS WITHIN THE CARGO AREA LENGTH

STRUCTURE IN WING BALLAST TANKS		
Structural member	Extent of measurement	Pattern of measurement
<i>Side shell and longitudinal bulkhead plating:</i> - upper strake and strakes in way of horizontal girders - all other strakes	- Plating between each pair of longitudinals in a minimum of three bays (along the tank) - Plating between every third pair of longitudinals in same three bays	- Single measurement - Single measurement
<i>Side shell and longitudinal bulkhead longitudinals on:</i> - upper strake - all other strakes	- Each longitudinal in same three bays - Every third longitudinal in same three bays	- 3 measurements across web and 1 measurement on flange - 3 measurements across web and 1 measurement on flange
<i>Longitudinals - brackets</i>	Minimum of three at top, middle and bottom of tank in same three bays	5-point pattern over area of bracket
<i>Vertical web and transverse bulkheads (excluding deckhead area):</i> - strakes in way of horizontal girders - other strakes	- Minimum of two webs and both transverse bulkheads - Minimum of two webs and both transverse bulkheads	- 5-point pattern over approx. two square metre area - two measurements between each pair of vertical stiffeners
<i>Horizontal girders</i>	Plating on each girder in a minimum of three bays	Two measurements between each pair of longitudinal girder stiffeners
<i>Panel stiffening</i>	Where applicable	Single measurements

Table IV, Sheet 4
REQUIREMENTS FOR EXTENT OF THICKNESS MEASUREMENTS AT THOSE AREAS OF SUBSTANTIAL CORROSION - RENEWAL SURVEY OF DOUBLE HULL OIL TANKERS WITHIN THE CARGO AREA LENGTH

LONGITUDINAL BULKHEADS IN CARGO TANKS		
Structural member	Extent of measurement	Pattern of measurement
<i>Deckhead and bottom strakes, and strakes in way of the horizontal stringers of transverse bulkheads</i>	Plating between each pair of longitudinals in a minimum of three bays	Single measurement
<i>All other strakes</i>	Plating between every third pair of longitudinals in same three bays	Single measurement
<i>Longitudinals on deckhead and bottom strakes</i>	Each longitudinal in same three bays	Three measurements across web and one measurement on flange
<i>All other longitudinals</i>	Every third longitudinal in same three bays	Three measurements across web and one measurement on flange
<i>Longitudinals - brackets</i>	Minimum of three at top, middle and bottom of tank in same three bays	5-point pattern over area of bracket
<i>Web frames and cross ties</i>	Three webs with minimum of three locations on each web, including in way of cross tie connections	5-point pattern over approximately two square metre area of webs, plus single measurements on flanges of web frame and cross ties
<i>Lower end brackets (opposite side of web frame)</i>	Minimum of three brackets	5-point pattern over approximately two square metre area of brackets, plus single measurements on bracket flanges

Table IV, Sheet 5
REQUIREMENTS FOR EXTENT OF THICKNESS MEASUREMENTS AT THOSE AREAS OF SUBSTANTIAL CORROSION - RENEWAL SURVEY OF DOUBLE HULL OIL TANKERS WITHIN THE CARGO AREA LENGTH

TRANSVERSE WATERTIGHT AND SWASH BULKHEADS IN CARGO TANKS		
Structural member	Extent of measurement	Pattern of measurement
<i>Upper and lower stool, where fitted</i>	Transverse band within 25 mm of welded connection to inner bottom/deck plating Transverse band within 25 mm of welded connection to shelf plate	5-point pattern between stiffeners over one metre length
<i>Deckhead and bottom strakes, and strakes in way of horizontal stringers</i>	Plating between pair of stiffeners at three locations : approximately 1/4, 1/2 and 3/4 width of tank	5-point pattern between stiffeners over one metre length
<i>All other strakes</i>	Plating between pair of stiffeners at middle location	Single measurement
<i>Strakes in corrugated bulkheads</i>	Plating for each change of scantling at centre of panel and at flange of fabricated connection	5-point pattern over about one square metre of plating
<i>Stiffeners</i>	Minimum of three typical stiffeners	For web, 5-point pattern over span between bracket connections (two measurements across web at each bracket connection and one at centre of span). For flange, single measurements at each bracket toe and at centre of span
<i>Brackets</i>	Minimum of three at top, middle and bottom of tank	5-point pattern over area of bracket
<i>Horizontal stringers</i>	All stringers with measurements at both ends and middle	5-point pattern over one square metre area, plus single measurements near bracket toes and on flanges

Table V
MINIMUM REQUIREMENTS FOR OVERALL AND CLOSE-UP SURVEY AND THICKNESS MEASUREMENTS AT INTERMEDIATE SURVEY OF DOUBLE HULL OIL TANKERS

AGE OF SHIP AT TIME OF INTERMEDIATE SURVEY DUE DATE		
$5 < \text{age} \leq 10$	$10 < \text{age} \leq 15$	$\text{age} > 15$
Overall survey of Representative ballast tanks selected by the attending surveyor (see 4.2.2)	The requirements of the previous Renewal Survey (see 4.2.3)	The requirements of the previous Renewal Survey (see 4.2.4)
Suspect areas identified at previous surveys are to be examined (see 4.2.2)		

ANNEX IVC

Ship Name:						
OWNERS INSPECTION REPORT - Structural Condition						
For Tank No:						
Grade of Steel:		Deck	:	Side	:	
		Bottom	:	Long. Bhd	:	
Elements	Cracks	Buckles	Corrosion	Coating	Pitting	Mod.
Other				cond.		/Rep.
Deck:						
Bottom:						
Side:						
Long. Bulkheads:						
Transv. Bulkheads:						
Repairs carried out due to:						
Thickness measurements carried out, dates:						
Results in General:						
Overdue Surveys:						
Outstanding Conditions of class:						
Comments:						
*Repairs are to be surveyed by the classification society						
Date of Inspection: _____						
Inspected by: _____						
Signature: _____						

ANNEX C1
Hull Surveys of Single Skin Bulk Carriers

Annex C1 HULL SURVEYS OF SINGLE SKIN BULK CARRIERS

Contents:

	Page
1 GENERAL.....	1
1.1 APPLICATION	1
1.2 DEFINITIONS	1
1.3 REPAIRS.....	4
1.4 THICKNESS MEASUREMENTS AND CLOSE-UP SURVEYS.....	4
2 RENEWAL (SPECIAL) SURVEY	5
2.1 SCHEDULE	5
2.2 SCOPE.....	5
2.3 EXTENT OF OVERALL AND CLOSE-UP SURVEYS.....	6
2.4 EXTENT OF THICKNESS MEASUREMENTS.....	6
2.5 EXTENT OF TANK TESTING	7
2.6 ADDITIONAL RENEWAL SURVEY REQUIREMENTS AFTER DETERMINING COMPLIANCE WITH SOLAS XII/12 AND XII/13.....	7
3 ANNUAL SURVEY	8
3.1 SCHEDULE	8
3.2 SCOPE.....	8
3.3 ADDITIONAL ANNUAL SURVEY REQUIREMENTS FOR THE FOREMOST CARGO HOLD OF SHIPS SUBJECT TO SOLAS XII/9.1.....	9
3.4 ADDITIONAL ANNUAL SURVEY REQUIREMENTS AFTER DETERMINING COMPLIANCE WITH SOLAS XII/12 AND XII/13.....	10
4 INTERMEDIATE SURVEY	11
4.1 SCHEDULE	11
4.2 SCOPE.....	11
5 PREPARATION FOR SURVEY	13
5.1 SURVEY PROGRAMME.....	13
5.2 CONDITIONS FOR SURVEY	13
5.3 ACCESS TO STRUCTURES.....	14
5.4 EQUIPMENT FOR SURVEY.....	14
5.5 RESCUE AND EMERGENCY RESPONSE EQUIPMENT	14
5.6 SURVEY AT SEA OR AT ANCHORAGE	15
5.7 SURVEY PLANNING MEETING	15
6 DOCUMENTATION ON BOARD	17
6.1 GENERAL.....	17
6.2 SURVEY REPORT FILE.....	17
6.3 SUPPORTING DOCUMENTS	17
6.4 REVIEW OF DOCUMENTATION ON BOARD	17
7 PROCEDURES FOR THICKNESS MEASUREMENTS	18
7.1 GENERAL.....	18
7.2 CERTIFICATION OF THICKNESS MEASUREMENTS FIRM.....	18
7.3 NUMBER AND LOCATIONS OF MEASUREMENTS	18
7.4 REPORTING.....	24
8 ACCEPTANCE CRITERIA.....	25
8.1 GENERAL.....	25
8.2 ACCEPTANCE CRITERIA FOR PITTING CORROSION OF CSR SHIPS.....	25
8.3 ACCEPTANCE CRITERIA FOR EDGE CORROSION OF CSR SHIPS.....	25
8.4 ACCEPTANCE CRITERIA FOR GROOVING CORROSION OF CSR SHIPS	26
9 REPORTING AND EVALUATION OF SURVEY.....	27
9.1 EVALUATION OF SURVEY REPORT	27
9.2 REPORTING.....	27

1 GENERAL

1.1 APPLICATION

1.1.1 The requirements apply to all self-propelled Bulk Carriers other than Double Skin Bulk Carriers.

1.1.2 The Requirements apply to surveys of hull structure and piping systems in way of the cargo holds, cofferdams, pipe tunnels, void spaces, fuel oil tanks within the cargo length area and all ballast tanks. The requirements are additional to the classification requirements applicable to the remainder of the ship. Refer to subtitles 4.2, 5.2 and 7. 2 in the *Rules for the classification of ships, Part 1 - General requirements, Chapter 5 - Surveys of ships in service.*

1.1.3 The requirements contain the minimum extent of examination, thickness measurement and tank testing. The survey is to be extended when Substantial Corrosion and/or structural defects are found and include additional Close-Up Survey when necessary.

1.1.4 Ships which are required to comply with IACS UR S19 are subject to the additional thickness measurement guidance contained in Annex III of IACS URZ10.2 with respect to the vertically corrugated transverse watertight bulkhead between cargo holds Nos. 1 and 2 for purposes of determining compliance with UR S19 prior to the relevant compliance deadline stipulated in UR S23 and at subsequent intermediate surveys (for ships over 10 years of age) and Renewal surveys for purposes of verifying continuing compliance with IACS UR S19.

1.1.5 Ships which are required to comply with IACS UR S31 are subject to the additional thickness measurement guidance contained in Annex V of IACS URZ10.2 with respect to the side shell frames and brackets for the purposes of determining compliance with IACS UR S31 prior to the relevant compliance deadline stipulated in IACS UR S31 and at subsequent intermediate and Renewal surveys for purposes of verifying continuing compliance with IACS UR S31.

1.1.6 For bulk carriers with hybrid cargo hold arrangements, e.g. with some cargo holds of single side skin and others of double side skin, the requirements contained in Annex C should to apply to cargo holds of double side skin and associated wing spaces.

1.2 DEFINITIONS

1.2.1 Bulk Carrier

A Bulk Carrier is a ship which is constructed generally with single deck, double bottom, topside tanks and hopper side tanks in cargo spaces, and is intended primarily to carry dry cargo in bulk. Combination carriers are included.¹⁾ Ore and combination carriers are not covered by the IACS Common Structural Rules.

1.2.2 Ballast Tank

A Ballast Tank is a tank which is used primarily for salt water ballast, or, where applicable, a space which is

used for both cargo and salt water ballast will be treated as a Ballast tank when substantial corrosion has been found in that space.

1.2.3 Spaces

Spaces are separate compartments including holds, tanks, cofferdams and void spaces bounding cargo holds, decks and the outer hull.

1.2.4 Overall Survey

An Overall Survey is a survey intended to report on the overall conditions of the hull structure and determine the extent of additional Close-Up Surveys.

1.2.5 Close-up Survey

A Close-up Survey is a survey where the details of structural components are within the close visual inspection range of the Surveyor, i.e. normally within reach of hand.

1.2.6 Transverse Section

A Transverse Section includes all longitudinal members such as plating, longitudinals and girders at the deck, sides, bottom, inner bottom hopper sides, longitudinal bulkheads and bottom in top wing tanks.

For transversely framed vessels, a transverse section includes adjacent frames and their end connections in way of transverse sections.

1.2.7 Representative Spaces

Representative Spaces are those which are expected to reflect the condition of other Spaces of similar type and service and with similar corrosion prevention systems. When selecting Representative Spaces account is to be taken of the service and repair history on board and identifiable Critical Structural Areas and/or Suspect Areas.

1.2.8 Suspect Areas

Suspect Areas are locations showing Substantial Corrosion and/or are considered by the Surveyor to be prone to rapid wastage.

1.2.9 Critical Structural Areas

Critical Structural Areas are locations which have been identified from calculations to require monitoring or from the service history of the subject ship or from similar or sister ships (if available) to be sensitive to cracking, buckling or corrosion which would impair the structural integrity of the ship.

1.2.10 Renewal Thickness

Renewal thickness (t_{ren}) is the minimum allowable thickness, in mm, below which renewal of structural members is to be carried out.

1.2.11 Substantial Corrosion

Substantial Corrosion is an extent of corrosion such that assessment of corrosion pattern indicates a wastage in excess of 75% of allowable margins, but within acceptable limits.

¹⁾ For single skin combination carriers additional requirements are specified in IACS UR Z10.1.

For vessels built under the IACS Common Structural Rules, substantial corrosion is an extent of corrosion such that the assessment of the corrosion pattern indicates a measured thickness between $t_{ren} + 0.5\text{mm}$ and t_{ren} .

1.2.12 Corrosion Prevention System

A Corrosion Prevention System is normally considered a full hard protective coating.

Hard Protective Coating is usually to be epoxy coating or equivalent. Other coating systems, which are neither soft nor semi-hard coatings, may be considered acceptable as alternatives provided that they are applied and maintained in compliance with the manufacturer's specifications.

1.2.13 Coating condition

Coating condition is defined as follows:

GOOD - condition with only minor spot rusting,

FAIR - condition with local breakdown at edges of stiffeners and weld connections and/or light rusting over 20% or more of areas under consideration, but less than as defined for POOR condition,

POOR - condition with general breakdown of coating over 20% or more of areas or hard scale at 10% or more of areas under consideration.

1.2.14 Cargo Length Area

Cargo Length Area is that part of the ship which includes cargo holds and adjacent areas including fuel tanks, cofferdams, ballast tanks and void spaces.

1.2.15 Special consideration

Special consideration or specially considered (in connection with close-up surveys and thickness measurements) means sufficient close-up inspection and thickness measurements are to be taken to confirm the actual average condition of the structure under the coating.

1.2.16 Prompt and Thorough Repair

A Prompt and Thorough Repair is a permanent repair completed at the time of survey to the satisfaction of the Surveyor, therein removing the need for the imposition of any associated condition of class.

1.2.17 Pitting Corrosion

Pitting corrosion is defined as scattered corrosion spots/areas with local material reductions which are greater than the general corrosion in the surrounding area. Pitting intensity is defined in Figure 1.

1.2.18 Edge Corrosion

Edge corrosion is defined as local corrosion at the free edges of plates, stiffeners, primary support members and around openings. An example of edge corrosion is shown in Figure 2.

1.2.19 Grooving Corrosion

Grooving corrosion is typically local material loss adjacent to weld joints along abutting stiffeners and at stiffener or plate butts or seams. An example of groove corrosion is shown in Figure 3.

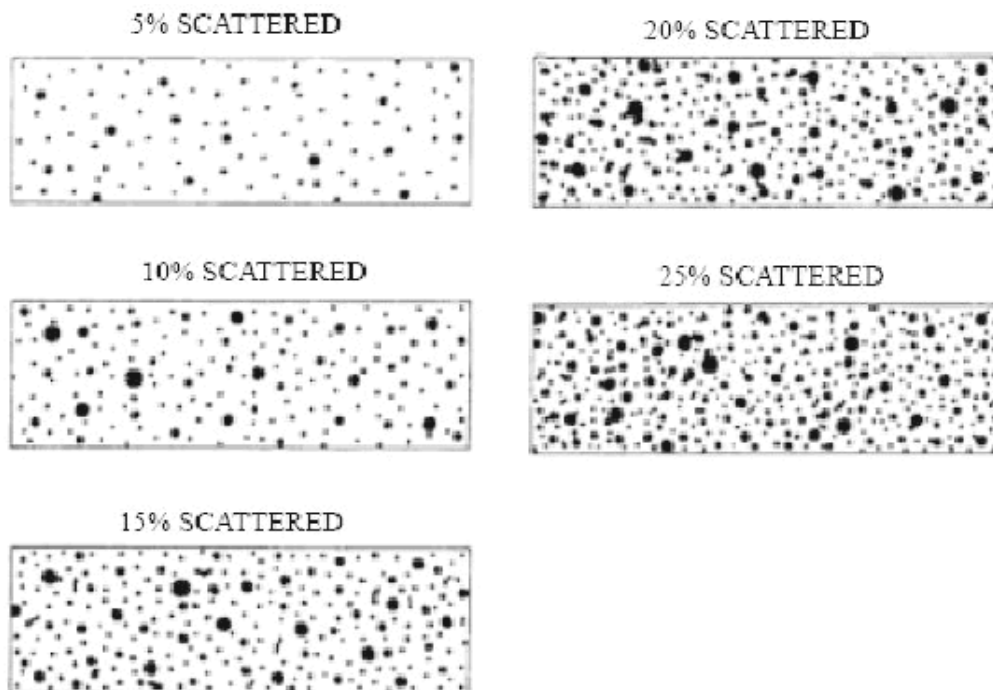

Figure 1 - Pitting intensity diagrams

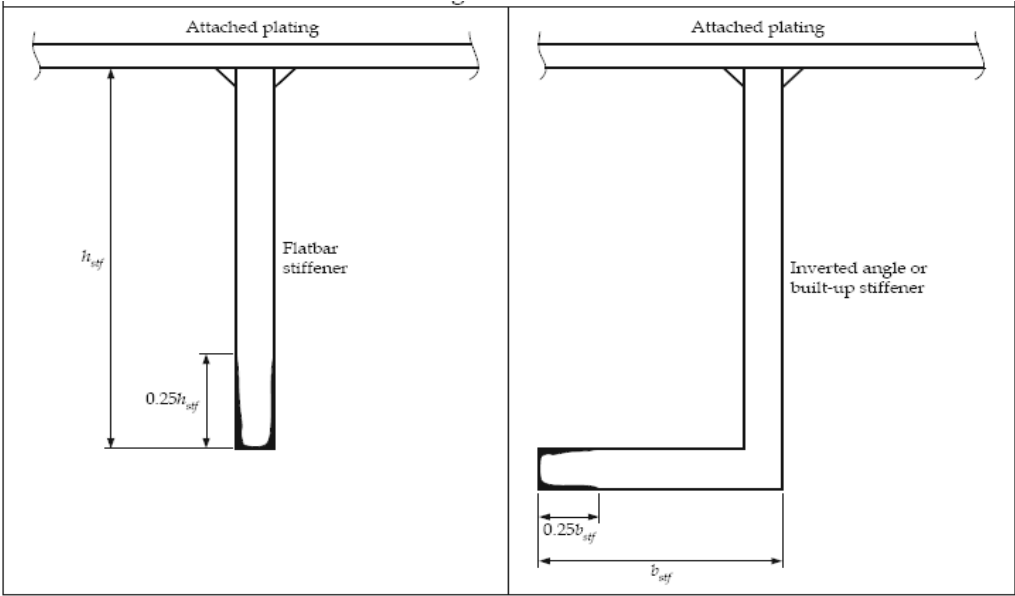

Figure 2 - Edge corrosion

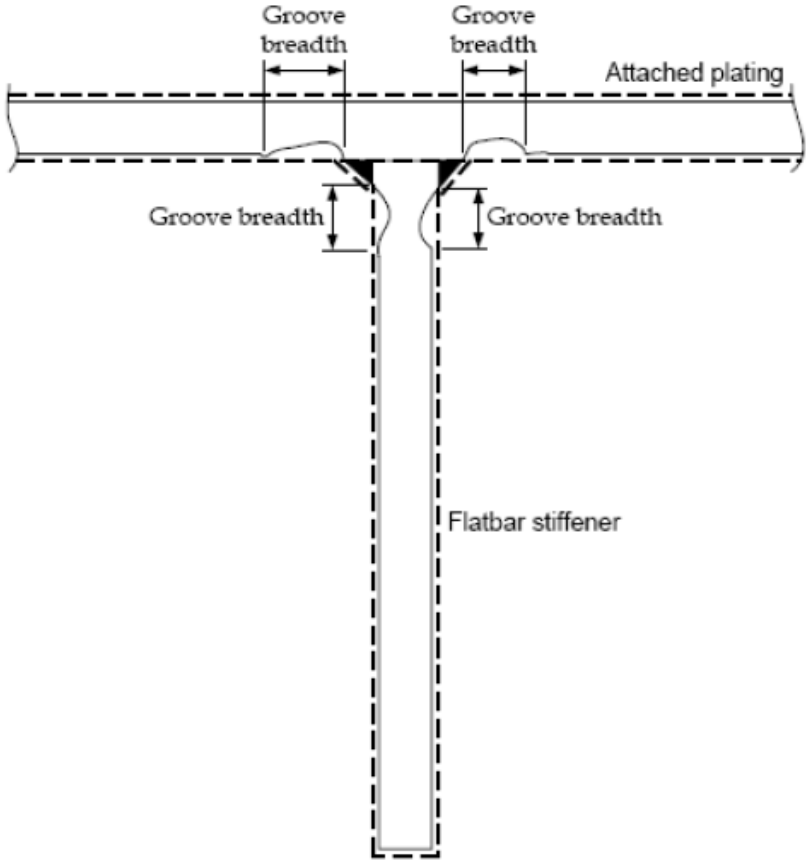

Figure 3 - Grooving corrosion

1.3 REPAIRS

1.3.1 Any damage in association with wastage over the allowable limits (including buckling, grooving, detachment or fracture), or extensive areas of wastage over the allowable limits, which affects or, in the opinion of the Surveyor, **will** affect the vessel's structural, watertight or weathertight integrity, is to be **promptly and thoroughly** (see 1.2.16) repaired. Areas to be considered include:

- bottom structure and bottom plating;
- side structure and side plating;
- deck structure and deck plating;
- inner bottom structure and inner bottom plating;
- inner side structure and inner side plating;
- watertight or oiltight bulkheads;
- hatch covers and hatch coamings;
- items in 3.2.3.10.

For locations where adequate repair facilities are not available, consideration may be given to allow the vessel to proceed directly to a repair facility. This may require discharging the cargo and/or temporary repairs for the intended voyage.

1.3.2 Additionally, when a survey results in the identification of structural defects or corrosion, either of which, in the opinion of the Surveyor, will impair the vessel's fitness for continued service, remedial measures are to be implemented before the ship continues in service.

1.3.3 Where the damage found on structure mentioned in Para. 1.3.1 is isolated and of a localised nature which does not affect the ship's structural integrity, consideration may be given by the surveyor to allow an appropriate temporary repair to restore watertight or weather tight integrity and impose a condition of class in accordance with IACS PR35, with a specific time limit.

1.4 THICKNESS MEASUREMENTS AND CLOSE-UP SURVEYS

1.4.1 In any kind of survey, i.e. Renewal, intermediate, annual or other surveys having the scope of the foregoing ones, thickness measurements, when required by Table II, of structures in areas where close-up surveys are required shall be carried out simultaneously with close-up surveys.

2 RENEWAL (SPECIAL) SURVEY

2.1 SCHEDULE

2.1.1 Renewal surveys are to be carried out at 5-year intervals to renew the Certificate of Class.

2.1.2 The first Renewal survey is to be completed within 5 years from the date of the initial survey and thereafter within 5 years from the credited date of the previous Renewal survey. However, an extension of class of 3 months maximum beyond the 5th year can be granted in exceptional circumstances.

In this case, the next period of class will start from the expiry date of the Renewal survey before the extension was granted.

2.1.3 For surveys completed within 3 months before the expiry date of the Renewal survey, the next period of validity of certificate will start from the expiry date of the Renewal survey. For surveys completed more than 3 months before the expiry date of the Renewal survey, the period of validity of certificate will start from the survey completion date. In cases where the vessel has been laid up or has been out of service for a considerable period because of a major repair or modification and the owner elects to only carry out the overdue surveys, the next period of class will start from the expiry date of the Renewal survey. If the owner elects to carry out the next due Renewal survey, the period of class will start from the survey completion date.

2.1.4 The Renewal survey may be commenced at the 4th annual survey and be progressed with a view to completion by the 5th anniversary date. When the Renewal survey is commenced prior to the 4th Annual survey, the entire survey is to be completed within 15 months if such work is to be credited to the Renewal survey.

2.1.5 Concurrent crediting to both Intermediate survey and Renewal survey for surveys and thickness measurements of spaces are not acceptable.

2.2 SCOPE

2.2.1 General

2.2.1.1 The Renewal survey is to include, in addition to the requirements of the annual survey, examination, tests and checks of sufficient extent to ensure that the hull and related piping, as required in 2.2.1.3, is in a satisfactory condition and is fit for its intended purpose for the new period of class of 5 years to be assigned, subject to proper maintenance and operation and to periodical surveys being carried out at the due dates.

2.2.1.2 All cargo holds, ballast tanks, including double bottom tanks, pipe tunnels, cofferdams and void spaces bounding cargo holds, decks and outer hull are to be examined, and this examination is to be supplemented by thickness measurement and testing as required in 2.4 and 2.5, to ensure that the structural integrity remains effective. The aim of the examination is to discover Substantial Corrosion, significant

deformation, fractures, damages, or other structural deterioration, that may be present.

2.2.1.3 All piping systems within the above spaces are to be examined and operationally tested to working pressure to attending Surveyor's satisfaction to ensure that tightness and condition remain satisfactory.

2.2.1.4 The survey extent of ballast tanks converted to void spaces is to be specially considered in relation to the requirements for ballast tanks.

2.2.2 Dry Dock Survey

2.2.2.1 A survey in dry dock is to be a part of the Renewal survey. The overall and close-up surveys and thickness measurements, as applicable, of the lower portions of the cargo holds and ballast tanks are to be carried out in accordance with the applicable requirements for Renewal surveys, if not already performed.

NOTE: Lower portions of the cargo holds, and ballast tanks are considered to be the parts below light ballast water line.

2.2.3 Space Protection

2.2.3.1 Where provided, the condition of the corrosion prevention system of ballast tanks is to be examined. For ballast tanks, excluding double bottom tanks, where the protective coating is found to be in less than GOOD condition, and it is not renewed, or where soft or semi-hard coating has been applied, or where a protective coating has not been applied from the time of construction, the tanks in question are to be examined at annual intervals. Thickness measurements are to be carried out as deemed necessary by the Surveyor.

When such a breakdown of coating is found in water ballast double bottom tanks and it is not renewed, where a soft or semi-hard coating is applied, or where the Protective Coating has not been applied from the time of construction, the tanks in question may be examined at annual intervals. When considered necessary by the Surveyor, or where extensive corrosion exists, thickness measurements are to be carried out.

2.2.3.2 Where a hard protective coating is provided in cargo holds and is found in GOOD condition, the extent of close-up surveys and thickness measurements may be specially considered.

2.2.4 Hatch Covers and Coamings

The hatch covers and coamings are to be surveyed as follows:

2.2.4.1 A thorough inspection of the items listed in 3.2.3 is to be carried out, in addition to all hatch covers and coamings.

2.2.4.2 Checking of the satisfactory operation of all mechanically operated hatch covers is to be made, including:

- stowage and securing in open condition;
- proper fit and efficiency of sealing in closed condition;
- operational testing of hydraulic and power components, wires, chains, and link drives.

2.2.4.3 Checking the effectiveness of sealing arrangements of all hatch covers by hose testing or equivalent.

2.2.4.4 Close-up survey and thickness measurement of the hatch cover and coaming plating and stiffeners is to be carried out as given in Table I and Table II. Subject to cargo hold hatch covers of approved design which structurally have no access to the internals, close-up survey shall be done of accessible parts of hatch covers structures.

2.3 EXTENT OF OVERALL AND CLOSE-UP SURVEYS

2.3.1 An overall survey of all tanks and spaces is to be carried out at each Renewal survey. Fuel oil tanks in the cargo length area are to be surveyed as follows:

I Renewal survey (age ≤ 5)	II Renewal survey (5 < age ≤ 10)	III Renewal survey (10 < age ≤ 15)	IV Renewal survey and Subsequent (age > 15)
None	One	Two	Half, minimum Two
NOTES:			
(1) These requirements apply to tanks of integral (structural) type.			
(2) If a selection of tanks is accepted to be examined, then different tanks are to be examined at each Renewal survey, on a rotational basis.			
(3) Peak tanks (all uses) are subject to internal examination at each Renewal survey.			
(4) At Renewal survey no 3 and subsequent surveys, one deep tank for fuel oil in the cargo area is to be included if fitted.			

2.3.2 The minimum requirements for close-up surveys at Renewal survey are given in Table I.

2.3.3 The Surveyor may extend the close-up survey as deemed necessary taking into account the maintenance of the spaces under survey, the condition of the corrosion prevention system and where spaces have structural arrangements or details which have suffered defects in similar spaces or on similar ships according to available information.

2.3.4 For areas in spaces where hard protective coatings are found to be in a GOOD condition, the extent of close-up surveys according to Table I may be specially considered by the *Register*, refer also to 2.2.3.2.

2.4 EXTENT OF THICKNESS MEASUREMENTS

2.4.1 The minimum requirements for thickness measurements at Renewal surveys are given in Table II.

For additional thickness measurement guidelines applicable to the vertically corrugated transverse watertight bulkhead between cargo hold Nos. 1 and 2 on ships subject to compliance with UR S19 and UR S23, reference is to be made to 1.1.4.

For additional thickness measurement guidelines applicable to the side shell frames and brackets on ships subject to compliance with UR S31, reference is to be made to 1.1.5.

2.4.2 Provisions for extended measurements for areas with Substantial Corrosion may be additionally specified in the Survey Programme as required by 5.1. These extended thickness measurements are to be carried out before the sur-

vey is credited as completed. Suspect Areas identified at previous surveys are to be examined. Areas of substantial corrosion identified at previous surveys are to have thickness measurements taken.

For vessels built under IACS Common Structural Rules, the identified substantial corrosion areas may be:

- a) protected by coating applied in accordance with the coating manufacturer's requirements and examined at annual intervals to confirm the coating in way is still in good condition, or alternatively
- b) required to be measured at annual intervals.

2.4.3 The Surveyor may further extend the thickness measurements as deemed necessary.

2.4.4 For areas in tanks where hard protective coatings are found to be in a GOOD condition, the extent of thickness measurements according to Table II may be specially considered. Refer also to 2.2.3.2.

2.4.5 Transverse sections are to be chosen where largest reductions are suspected to occur or are revealed from deck plating measurements, one of which is to be in the amidships area.

2.4.6 Representative thickness measurement to determine both general and local levels of corrosion in the shell frames and their end attachments in all cargo holds and water ballast tanks is to be carried out. Thickness measurement is also to be carried out to determine the corrosion levels on the transverse bulkhead plating. The extent of thickness measurements may be specially considered provided the Surveyor is satisfied by the close-up survey, that there is no structural

diminution, and the hard protective coating where applied remains efficient.

2.5 EXTENT OF TANK TESTING

2.5.1 All boundaries of water ballast tanks, deep tanks and cargo holds used for water ballast within the cargo length area are to be pressure tested. For Fuel Oil Tanks, only representative tanks are to be pressure tested.

2.5.2 The Surveyor may extend the tank testing as deemed necessary.

2.5.3 Boundaries of ballast tanks are to be tested with a head of liquid to the top of air pipes.

2.5.4 Boundaries of ballast holds are to be tested with a head of liquid to near to the top of hatches.

2.5.5 Boundaries of fuel oil tanks are to be tested with a head of liquid to the highest point that liquid will rise under service conditions. Tank testing of fuel oil tanks may be specially considered based on a satisfactory external examination of the tank boundaries, and a confirmation from the Master stating that the pressure testing has been carried out according to the requirements with satisfactory results.

2.5.6 The testing of double bottom tanks and other spaces not designed for the carriage of liquid may be omitted, provided a satisfactory internal examination together with an examination of the tank top is carried out.

2.6 ADDITIONAL RENEWAL SURVEY REQUIREMENTS AFTER DETERMINING COMPLIANCE WITH SOLAS XII/12 AND XII/13

2.6.1 For ships complying with the requirements of SOLAS XII/12 for hold, ballast and dry space water level detectors, the Renewal survey is to include an examination and a test of the water ingress detection systems and of their alarms.

2.6.2 For ships complying with the requirements of SOLAS XII/13 for the availability of pumping systems, the Renewal survey is to include an examination and a test of the means for draining and pumping ballast tanks forward of the collision bulkhead and bilges of dry spaces any part of which extends forward of the foremost cargo hold, and of their controls.

3 ANNUAL SURVEY

3.1 SCHEDULE

3.1.1 Annual Surveys are to be held within 3 months before or after anniversary date from the date of the initial classification survey or of the date credited for the last Renewal survey.

3.2 SCOPE

3.2.1 General

3.2.1.1 The survey is to consist of an examination for the purpose of ensuring, as far as practicable, that the hull, weather decks, hatch covers, coamings and piping are maintained in a satisfactory condition and should take into account the service history, condition and extent of the corrosion prevention system of ballast tanks and areas identified in the survey report file.

3.2.2 Examination of the hull

3.2.2.1 Examination of the hull plating and its closing appliances as far as can be seen.

3.2.2.2 Examination of watertight penetrations as far as practicable.

3.2.3 Examination of weather decks, hatch covers and coamings

3.2.3.1 Confirmation is to be obtained that no unapproved changes have been made to the hatch covers, hatch coamings and their securing and sealing devices since the last survey.

3.2.3.2 A thorough survey of cargo hatch covers and coamings is only possible by examination in the open as well as closed positions and should include verification of proper opening and closing operation. As a result, the hatch cover sets within the forward 25% of the ship's length and at least one additional set, such that all sets on the ship are assessed at least once in every 5-year period, are to be surveyed open, closed and in operation to the full extent on each direction at each annual survey, including:

- .1 stowage and securing in open condition;
- .2 proper fit and efficiency of sealing in closed condition; and
- .3 operational testing of hydraulic and power components, wires, chains, and link drives.

The closing of the covers is to include the fastening of all peripheral, and cross joint cleats or other securing devices. Particular attention is to be paid to the condition of the hatch covers in the forward 25% of the ship's length, where sea loads are normally greatest.

3.2.3.3 If there are indications of difficulty in operating and securing hatch covers, additional sets above those required by 3.2.3.2, at the discretion of the surveyor, are to be tested in operation.

3.2.3.4 Where the cargo hatch securing system does not function properly, repairs are to be carried out under the

supervision of the *Register*. Where hatch covers or coamings undergo substantial repairs, the strength of securing devices should be upgraded to comply with S21.5 of UR S21.

3.2.3.5 For each cargo hatch cover set, at each annual survey, the following items are to be surveyed:

- .1 Cover panels, including side plates, and stiffener attachments that may be accessible in the open position by close-up survey (for corrosion, cracks, deformation);
- .2 sealing arrangements of perimeter and cross joints (gaskets for condition and permanent deformation, flexible seals on combination carriers, gasket lips, compression bars, drainage channels and non-return valves);
- .3 clamping devices, retaining bars, cleating (for wastage, adjustment, and condition of rubber components);
- .4 closed cover locating devices (for distortion and attachment);
- .5 chain or rope pulleys;
- .6 guides;
- .7 guide rails and track wheels;
- .8 stoppers;
- .9 wires, chains, tensioners, and gypsies;
- .10 hydraulic system, electrical safety devices and interlocks; and
- .11 end and interpanel hinges, pins and stools where fitted.

3.2.3.6 At each hatchway, at each annual survey, the coamings, with plating, stiffeners and brackets are to be checked for corrosion, cracks and deformation, especially of the coaming tops, including close-up survey.

3.2.3.7 Where considered necessary, the effectiveness of sealing arrangements may be proved by hose or chalk testing supplemented by dimensional measurements of seal compressing components.

3.2.3.8 Where portable covers, wooden or steel pontoons are fitted, checking the satisfactory condition, where applicable, of:

- wooden covers and portable beams, carriers or sockets for the portable beam, and their securing devices;
- steel pontoons, including close-up survey of hatch cover plating;
- tarpaulins;
- cleats, battens and wedges;
- hatch securing bars and their securing devices;
- loading pads/bars and the side plate edge;
- guide plates and chocks;
- compression bars, drainage channels and drain pipes (if any).

3.2.3.9 Examination of flame screens on vents to all bunker tanks.

3.2.3.10 Examination of bunker and vent piping systems, including ventilators.

3.2.4 Examination of Cargo Holds

3.2.4.1 Bulk Carriers 10-15 years of age. The following is to apply:

- a) Overall survey of all cargo holds.
- b) Close-up survey of sufficient extent, minimum 25% of frames, to establish the condition of the lower region of the shell frames including approx. lower one third length of side frame at side shell and side frame end attachment and the adjacent shell plating in the forward cargo hold. Where this level of survey reveals the need for remedial measures, the survey is to be extended to include a Close-up Survey of all of the shell frames and adjacent shell plating of that cargo hold as well as a Close-up survey of sufficient extent of all remaining cargo holds.
- c) When considered necessary by the surveyor, or where extensive corrosion exists, thickness measurement is to be carried out. If the results of these thickness measurements indicate that Substantial Corrosion is found, the extent of thickness measurements is to be increased. These thickness measurements are to be carried out before the annual survey is credited as completed. Suspect Areas identified at previous surveys are to be examined. Areas of substantial corrosion identified at previous surveys are to have thickness measurements taken.
For vessels built under the IACS Common Structural Rules, the annual thickness gauging may be omitted where a protective coating has been applied in accordance with the coating manufacturer's requirements and is maintained in good condition.
- d) Where the protective coating in cargo holds, as defined in 1.2.13, is found to be in GOOD condition, the extent of close-up surveys and thickness measurements may be specially considered.
- e) All piping and penetrations in cargo holds, including overboard piping, are to be examined.

3.2.4.2 Bulk Carriers over 15 years of age, the following is to apply:

- a) Overall survey of all cargo holds.
- b) Close-up survey of sufficient extent, minimum 25% of frames, to establish the condition of the lower region of the shell frames including approx. lower one third length of side frame at side shell and side frame end attachment and the adjacent shell plating in the forward cargo hold and one other selected cargo hold. Where this level of survey reveals the need for remedial measures, the survey is to be extended to include a Close-up Survey of all of the shell frames and adjacent shell plating of that cargo hold as well as

a Close-up Survey of sufficient extent of all remaining cargo holds.

- c) When considered necessary by the surveyor, or where extensive corrosion exists, thickness measurement is to be carried out. If the results of these thickness measurements indicate that Substantial Corrosion is found, the extent of thickness measurements is to be increased. These extended thickness measurements are to be carried out before the annual survey is credited as completed. Suspect Areas identified at previous surveys are to be examined. Areas of substantial corrosion identified at previous surveys are to have thickness measurements taken.
For vessels built under the IACS Common Structural Rules, the annual thickness gauging may be omitted where a protective coating has been applied in accordance with the coating manufacturer's requirements and is maintained in good condition.
- d) Where a hard protective coating is fitted in cargo holds, as defined in 1.2.13, and is found in GOOD condition, the extent of close-up surveys and thickness measurements may be specially considered
- e) All piping and penetrations in cargo holds, including overboard piping, are to be examined.

3.2.5 Examination of ballast tanks

3.2.5.1 Examination of Ballast Tanks when required as a consequence of the results of the Renewal Survey and Intermediate Survey is to be carried out. When considered necessary by the surveyor, or where extensive corrosion exists, thickness measurements are to be carried out. If the results of these thickness measurements indicate that Substantial Corrosion is found, the extent of thickness measurements is to be increased. These extended thickness measurements are to be carried out before the survey is credited as completed. Suspect Areas identified at previous surveys are to be examined. Areas of substantial corrosion identified at previous survey are to have thickness measurements taken.

For vessels built under the IACS Common Structural Rules, the annual thickness gauging may be omitted where a protective coating has been applied in accordance with the coating manufacturer's requirements and is maintained in good condition.

3.3 ADDITIONAL ANNUAL SURVEY REQUIREMENTS FOR THE FOREMOST CARGO HOLD OF SHIPS SUBJECT TO SOLAS XII/9.1

3.3.1 Ships subject to SOLAS XII/9.1 are those meeting all the following conditions:

- Bulk Carriers of 150m in length and upwards of single side skin construction,
- carrying solid bulk cargoes having a density of 1780 kg/m³ and above,

- contracted for construction (see Note 1) before 1 July 1999, and
- constructed with an insufficient number of transverse watertight bulkheads to enable them to withstand flooding of the foremost cargo hold in all loading conditions and remain afloat in a satisfactory condition of equilibrium as specified in SOLAS XII/4.3.

3.3.2 In accordance with SOLAS XII/9.1, for the foremost cargo hold of such ships, the additional survey requirements, listed in Annex IV of IACS URZ10.2, shall apply.

NOTE: The “contracted for construction” date means the date on which the contract to build the vessel is signed between the prospective owner and the shipbuilder. For further details regarding the date of “contract for construction”, refer to IACS Procedural Requirement (PR) No.29.

3.4 ADDITIONAL ANNUAL SURVEY REQUIREMENTS AFTER DETERMINING COMPLIANCE WITH SOLAS XII/12 AND XII/13

3.4.1 For ships complying with the requirements of SOLAS XII/12 for hold, ballast and dry space water level detectors, the annual survey is to include an examination and a test, at random, of the water ingress detection systems and of their alarms.

3.4.2 For ships complying with the requirements of SOLAS XII/13 for the availability of pumping systems, the annual survey is to include an examination and a test, of the means for draining and pumping ballast tanks forward of the collision bulkhead and bilges of dry spaces any part of which extends forward of the foremost cargo hold, and of their controls.

4 INTERMEDIATE SURVEY

4.1 SCHEDULE

4.1.1 The Intermediate Survey is to be held at or between either the 2nd or 3rd annual survey.

4.1.2 Those items, which are additional to the requirements of the annual survey, may be surveyed either at or between the 2nd and 3rd annual survey.

4.1.3 Concurrent crediting to both Intermediate survey and Renewal survey for surveys and thickness measurements of spaces are not acceptable.

4.2 SCOPE

4.2.1 General

4.2.1.1 The survey extent is dependent on the age of the vessel as specified in 4.2.2 to 4.2.4.

4.2.2 Bulk Carriers 5 - 10 years of age

The following is to apply:

4.2.2.1 Ballast Tanks

- For tanks used for water ballast, an overall survey of representative tanks selected by the Surveyor is to be carried out. The selection is to include fore and aft peak tanks and a number of other tanks, taking into account the total number and type of ballast tanks. If such overall survey reveals no visible structural defects, the examination may be limited to verification that the corrosion prevention system remains efficient.
- b) Where a hard coating is found to be in less than GOOD condition, corrosion or other defects are found in water ballast tanks or where a protective coating was not applied from the time of construction, the examination is to be extended to other ballast tanks of the same type.
 - c) In ballast tanks other than double bottom tanks, where a protective coating is found to be in less than GOOD condition, and it is not renewed, or where soft or semi-hard coating has been applied, or where a protective coating was not applied from the time of construction, the tanks in question are to be examined and thickness measurements carried out as considered necessary at annual intervals. When such breakdown of coating is found in ballast double bottom tanks, or where a soft or semi-hard coating has been applied, or where a coating has not been applied, the tanks in question may be examined at annual intervals. When considered necessary by the Surveyor, or where extensive corrosion exists, thickness measurements are to be carried out.
 - d) In addition to the requirements above,

suspect areas identified at previous surveys are to be overall and close-up surveyed.

4.2.2.2 Cargo Holds

- a) An overall survey of all cargo holds, including close-up survey of sufficient extent, minimum 25 % of frames, is to be carried out to establish the condition of:
 - shell frames including their upper and lower end attachments, adjacent shell plating, and transverse bulkheads in the forward cargo hold and one other selected cargo hold;
 - areas found suspect at previous surveys.
- b) Where considered necessary by the Surveyor as a result of the overall survey as described in 4.2.2.2a, the survey is to be extended to include a close-up survey of all of the shell frames and adjacent shell plating of that cargo hold as well as a close-up survey of sufficient extent of all remaining cargo holds.

4.2.2.3 Extent of Thickness Measurements

- a) Thickness measurements are to be carried out to an extent sufficient to determine both general and local corrosion levels at areas subject to close-up survey, where required as per 4.2.2.2a. The minimum requirement for thickness measurements at the Intermediate Survey are areas found to be Suspect Areas at previous surveys.
- b) The extent of thickness measurement may be specially considered provided the Surveyor is satisfied by the close-up survey that there is no structural diminution and the hard protective coatings are found to be in a GOOD condition.
- c) Where Substantial Corrosion is found, the extent of thickness measurements is to be increased. These extended thickness measurements are to be carried out before the survey is credited as completed. Suspect Areas identified at previous surveys are to be examined. Areas of substantial corrosion identified at previous surveys are to have thickness measurements taken.

For vessels built under IACS Common Structural Rules, the identified substantial corrosion areas may be:

 - protected by coating applied in accordance with the coating manufacturer's requirements and examined at annual intervals to confirm the coating in way is still in good condition, or alternatively;
 - required to be measured at annual intervals.
- d) Where the hard protective coating in cargo holds, as defined in 1.2.13, is found to be in GOOD condition, the extent of

close-up surveys and thickness measurements may be specially considered.

EXPLANATORY NOTE: For existing bulk carriers, where owners may elect to coat or recoat cargo holds as noted above, consideration may be given to the extent of the close-up and thickness measurement surveys. Prior to the coating of cargo holds of existing ships, scantlings should be ascertained in the presence of a surveyor.

4.2.3 Bulk Carriers 10 – 15 years of age

The following is to apply:

4.2.3.1 The requirements of the intermediate survey are to be to the same extent as the previous Renewal survey as required in 2 and 5.1. However, internal examination of fuel oil tanks and pressure testing of all tanks are not required unless deemed necessary by the attending Surveyor.

4.2.3.2 In application of 4.2.3.1, the intermediate survey may be commenced at the second annual survey and be progressed during the succeeding year with a view to completion at the third annual survey in lieu of the application of 2.1.4.

4.2.3.3 In application of 4.2.3.1, an underwater survey may be considered in lieu of the requirement of 2.2.2.

4.2.4 Bulk Carriers over 15 years of age

The following is to apply:

4.2.4.1 The requirements of the intermediate survey are to be to the same extent as the previous Renewal survey as required in 2 and 5.1.

However, internal examination of fuel oil tanks and pressure testing of all tanks are not required unless deemed necessary by the attending Surveyor.

4.2.4.2 In application of 4.2.4.1, the intermediate survey may be commenced at the second annual survey and be progressed during the succeeding year with a view to completion at the third annual survey in lieu of the application of 2.1.4.

4.2.4.3 In application of 4.2.4.1, a survey in dry dock is to be part of the intermediate survey. The overall and close-up surveys and thickness measurements, as applicable, of the lower portions of the cargo holds and ballast tanks are to be carried out in accordance with the applicable requirements for intermediate surveys, if not already performed.

NOTE: Lower portions of the cargo holds and ballast tanks are considered to be the parts below light ballast water line.

5 PREPARATION FOR SURVEY

5.1 SURVEY PROGRAMME

5.1.1 The Owner in co-operation with the *Register* is to work out a specific Survey Programme prior to the commencement of any part of:

- the Renewal Survey
- the Intermediate Survey for bulk carriers over 10 years of age.

The Survey Programme is to be in a written format. The survey is not to commence until the Survey programme has been agreed.

5.1.1.1. Prior to the development of the survey programme, the survey planning questionnaire is to be completed by the owner, and forwarded to the *Register*.

5.1.1.2 The Survey Programme at Intermediate Survey may consist of the Survey Programme at the previous Renewal survey supplemented by the Executive Hull Summary of that Renewal survey and later relevant survey reports.

The Survey Programme is to be worked out taking into account any amendments to the survey requirements implemented after the last Renewal survey carried out.

5.1.2 In developing the survey programme, the following documentation is to be collected and consulted with a view to selecting holds, tanks, areas, and structural elements to be examined:

- survey status and basic ship information,
- documentation on-board, as described in 6.2 and 6.3,
- main structural plans (scantlings drawings), including information regarding use of high tensile steels (HTS),
- relevant previous survey and inspection reports from both the *Register* and the Owner,
- information regarding the use of the ship's holds and tanks, typical cargoes and other relevant data,
- information regarding corrosion prevention level on the newbuilding,
- information regarding the relevant maintenance level during operation.

5.1.3 The submitted survey programme is to account for and comply, as a minimum, with the requirements of Tables I and II and paragraph 2.5 for close-up survey, thickness measurement and tank testing, respectively, and is to include relevant information including at least:

- basic ship information and particulars,
- main structural plans (scantling drawings), including information regarding use of high tensile steels (HTS),
- plan of holds and tanks,
- list of holds and tanks with information on use, protection, and condition of coating,
- conditions for survey (e.g., information

regarding hold and tank cleaning, gas freeing, ventilation, lighting, etc.),

- provisions and methods for access to structures,
- equipment for surveys,
- nomination of holds and tanks and areas for close-up survey (per 2.3),
- nominations of sections and areas for thickness measurement (per 2.4),
- nomination of tanks for tank testing (per 2.5),
- damage experience related to the ship in question.

5.1.4 The *Register* will advise the Owner of the maximum acceptable structural corrosion diminution levels applicable to the vessel.

5.2 CONDITIONS FOR SURVEY

5.2.1 The Owner is to provide the necessary facilities for a safe execution of the survey.

5.2.1.1 In order to enable the attending surveyors to carry out the survey, provisions for proper and safe access, are to be agreed between the owner and the *Register* and are to be in accordance with IACS PR 37.

5.2.1.2 Details of the means of access are to be provided in the survey planning questionnaire.

5.2.1.3 In cases where the provisions of safety and required access are judged by the attending surveyor(s) not to be adequate, the survey of the spaces involved is not to proceed.

5.2.2 Cargo holds, tanks and spaces are to be safe for access. Cargo holds, tanks and spaces are to be gas free and properly ventilated. Prior to entering a tank, void or enclosed space, it is to be verified that the atmosphere in the tank is free from hazardous gas and contains sufficient oxygen.

5.2.3 In preparation for survey and thickness measurements and to allow for a thorough examination, all spaces are to be cleaned including removal from surfaces of all loose accumulated corrosion scale. Spaces are to be sufficiently clean and free from water, scale, dirt, oil residues etc. to reveal corrosion, deformation, fractures, damages, or other structural deterioration. However, those areas of structure whose renewal has already been decided by the owner need only be cleaned and descaled to the extent necessary to determine the limits of areas to be renewed.

5.2.4 Sufficient illumination is to be provided to reveal corrosion, deformation, fractures, damages, or other structural deterioration as well as the condition of the coating.

5.2.5 Where soft or semi-hard coatings have been applied, safe access is to be provided for the surveyor to verify the effectiveness of the coating and to carry out an assessment of the conditions of internal structures which may include spot removal of the coating. When safe access cannot be provided, the soft or semi-hard coating is to be removed.

5.3 ACCESS TO STRUCTURES

5.3.1 For overall surveys, means are to be provided to enable the Surveyor to examine the hull structure in a safe and practical way.

5.3.2 For close-up surveys of the hull structure, other than cargo hold shell frames, one or more of the following means for access, acceptable to the Surveyor, is to be provided:

- permanent staging and passages through structures,
- temporary staging and passages through structures,
- hydraulic arm vehicles such as conventional cherry pickers, lifts and movable platforms,
- portable ladders,
- boats or rafts,
- other equivalent means.

5.3.3 For close-up surveys of the cargo hold shell frames of bulk carriers less than 100,000 dwt, one or more of the following means for access, acceptable to the Surveyor, is to be provided:

- permanent staging and passages through structures;
- temporary staging and passages through structures;
- portable ladder restricted to not more than 5 m in length may be accepted for surveys of lower section of a shell frame including bracket;
- hydraulic arm vehicles such as conventional cherry pickers, lifts and movable platforms;
- boats or rafts provided the structural capacity of the hold is sufficient to withstand static loads at all levels of water;
- other equivalent means.

5.3.4 For close-up surveys of the cargo hold shell frames of bulk carriers 100,000 dwt and above, the use of portable ladders is not accepted, and one or more of the following means for access, acceptable to the surveyor, is to be provided:

Annual Surveys, Intermediate Survey under 10 years of age and Renewal Survey No. 1:

- permanent staging and passages through structures;
- temporary staging and passages through structures;
- hydraulic arm vehicles such as conventional cherry pickers, lifts and movable platforms;
- boats or rafts provided the structural capacity of the hold is sufficient to withstand static loads at all levels of water;
- other equivalent means.

Subsequent Intermediate Surveys and Renewal Surveys:

- either permanent or temporary staging and passage through structures for close-up survey of at least the upper part of hold frames;

- hydraulic arm vehicles such as conventional cherry pickers for surveys of lower and middle part of shell frames as alternative to staging;
- lifts and movable platforms;
- boats or rafts provided the structural capacity of the hold is sufficient to withstand static loads at all levels of water;
- other equivalent means.

Notwithstanding the above requirements:

- a) the use of a portable ladder fitted with a mechanical device to secure the upper end of the ladder is acceptable for the "close-up examination of sufficient extent, minimum 25% of frames, to establish the condition of the lower region of the shell frames including approx. lower one third length of side frame at side shell and side frame end attachment and the adjacent shell plating of the forward cargo hold" at Annual Survey, required in 3.2.4.1.b, and the "one other selected cargo hold" required in 3.2.4.2.b.
- b) the use of hydraulic arm vehicles or aerial lifts ("Cherry picker") may be accepted by the attending surveyor for the close-up survey of the upper part of side shell frames or other structures in all cases where the maximum working height is not more than 17 m.

5.4 EQUIPMENT FOR SURVEY

5.4.1 Thickness measurement is normally to be carried out by means of ultrasonic test equipment. The accuracy of the equipment is to be proven to the Surveyor as required.

5.4.2 One or more of the following fracture detection procedures may be required if deemed necessary by the Surveyor:

- radiographic equipment,
- ultrasonic equipment,
- magnetic particle equipment,
- dye penetrant.

5.4.3 Explosimeter, oxygen-meter, breathing apparatus, lifelines, riding belts with rope and hook and whistles together with instructions and guidance on their use are to be made available during the survey. A safety check-list is to be provided.

5.4.4 Adequate and safe lighting is to be provided for the safe and efficient conduct of the survey.

5.4.5 Adequate protective clothing is to be made available and used (e.g. safety helmet, gloves, safety shoes, etc.) during the survey.

5.5 RESCUE AND EMERGENCY RESPONSE EQUIPMENT

5.5.1 If breathing apparatus and/or other equipment is used as 'Rescue and emergency response equipment' then it is recommended that the equipment should be suitable for the configuration of the space being surveyed.

5.6 SURVEY AT SEA OR AT ANCHORAGE

5.6.1 Survey at sea or at anchorage may be accepted provided the Surveyor is given the necessary assistance from the personnel onboard. Necessary precautions and procedures for carrying out the survey are to be in accordance with 5.1, 5.2, 5.3 and 5.4.

5.6.2 A communication system is to be arranged between the survey party in the spaces under examination and the responsible officer on deck. This system is to also include the personnel in charge of ballast pump handling if boats or rafts are used.

5.6.3 Surveys of tanks or applicable holds by means of boats or rafts may only be undertaken with the agreement of the Surveyor, who is to take into account the safety arrangements provided, including weather forecasting and ship response under foreseeable conditions and provided the expected rise of water within the tank does not exceed 0.25m.

5.6.4 When rafts or boats are used for close-up surveys, the following conditions are to be observed:

- .1 only rough duty, inflatable rafts or boats, having satisfactory residual buoyancy and stability even if one chamber is ruptured, should be used;
- .2 the boat or raft should be tethered to the access ladder and an additional person should be stationed down the access ladder with a clear view of the boat or raft;
- .3 appropriate lifejackets should be available for all participants;
- .4 the surface of water in the tank should be calm (under all foreseeable conditions the expected rise of water within the tank should not exceed 0.25 m) and the water level either stationary. On no account should the level of the water be rising while the boat or raft is in use;
- .5 the tank or space must contain clean ballast water only. Even a thin sheen of oil on the water is not acceptable;
- .6 at no time should the water level be allowed to be within 1 m of the deepest under deck web face flat so that the survey team is not isolated from a direct escape route to the tank hatch. Filling to levels above the deck transverses should only be contemplated if a deck access manhole is fitted and open in the bay being examined, so that an escape route for the survey party is available at all times. Other effective means of escape to the deck may be considered.

5.6.5 Rafts or boats alone may be allowed for inspection of the underdeck areas for tanks or spaces if the depth of the webs is 1.5 meters or less.

5.6.6 If the depth of the webs is more than 1.5 m, rafts or boats alone may be allowed only:

- .1 when the coating of the underdeck structure is in GOOD condition and there is no

- evidence of wastage; or
- .2 if a permanent means of access is provided in each bay to allow safe entry and exit. This means:
 - i. access direct from the deck via a vertical ladder and a small platform fitted approximately 2 m below the deck in each bay; or
 - ii. access to deck from a longitudinal permanent platform having ladders to deck in each end of the tank. The platform shall, for the full length of the tank, be arranged in level with, or above, the maximum water level needed for rafting of under deck structure. For this purpose, the ullage corresponding to the maximum water level is to be assumed not more than 3m from the deck plate measured at the midspan of deck transverses and in the middle length of the tank.

If neither of the above conditions are met, then staging or another equivalent means is to be provided for the survey of the underdeck areas.

5.6.7 The use of rafts or boats alone in paragraphs 5.6.5 and 5.6.6 does not preclude the use of boats or rafts to move about within a tank during a survey.

NOTE: Reference is made to IACS Recommendation 39 – Guidelines for use of Boats or Rafts for Close-up Surveys.

5.7 SURVEY PLANNING MEETING

5.7.1 The establishment of proper preparation and close co-operation between the attending surveyor(s) and the owner's representatives onboard prior to and during the survey are an essential part in the safe and efficient conduct of the survey. During the survey on board safety meetings are to be held regularly.

5.7.2 Prior to commencement of any part of the renewal and intermediate survey, a survey planning meeting is to be held between the attending surveyor(s), the owner's representative in attendance, the TM firm representative, where involved, and the master of the ship or an appropriately qualified representative appointed by the master or Company for the purpose to ascertain that all the arrangements envisaged in the survey programme are in place, so as to ensure the safe and efficient conduct of the survey work to be carried out. See also 7.1.2.

5.7.3 The following is an indicative list of items that are to be addressed in the meeting:

- .1 schedule of the vessel (i.e. the voyage, docking and undocking manoeuvres, periods alongside, cargo and ballast operations, etc.);
- .2 provisions and arrangements for thickness measurements (i.e. access, cleaning/de-scaling, illumination, ventilation, personal safety);
- .3 extent of the thickness measurements;
- .4 acceptance criteria (refer to the list of minimum thicknesses);
- .5 extent of close-up survey and thickness

- measurement considering the coating condition and suspect areas/areas of substantial corrosion;
- .6 execution of thickness measurements;
 - .7 taking representative readings in general and where uneven corrosion/pitting is found;
 - .8 mapping of areas of substantial corrosion; and
 - .9 communication between attending surveyor(s) the thickness measurement firm operator(s) and owner representative(s) concerning findings.

6 DOCUMENTATION ON BOARD

6.1 GENERAL

6.1.1 The Owner is to obtain, supply and maintain on board documentation as specified in 6.2 and 6.3, which is to be readily available for the Surveyor.

6.1.2 The documentation is to be kept on board for the life time of the ship.

6.1.3 For ships defined in the *Rules for the classification of ships, Part - General requirements, Chapter 2 - Survey during construction and initial survey*, under the note in 1.2.2.27 the following is to be applied to surveys commenced on or after 1st July 2016.

For tankers and bulk carriers subject to SOLAS Chapter II-1 Part A-1 Regulation 3-10, the Owner is to arrange the updating of the Ship Construction File (SCF) throughout the ship's life whenever a modification of the documentation included in the SCF has taken place. Documented procedures for updating the SCF are to be included within the Safety Management System.

6.2 SURVEY REPORT FILE

6.2.1 A Survey Report File is to be a part of the documentation on board consisting of:

- reports of structural surveys,
- Executive Hull Summary,
- thickness measurement reports.

6.2.2 The Survey Report File is to be available also in the Owner's and the *Registers* management offices.

6.3 SUPPORTING DOCUMENTS

6.3.1 The following additional documentation is to be available onboard:

- Survey Programme as required by 5.1 until such time as the Renewal Survey or Intermediate Survey, as applicable, has been completed.
- Main structural plans of cargo holds and Ballast Tanks (for CSR ships these plans are to include for each structural element both the as-built and renewal thickness. Any thickness for voluntary addition is also to be clearly indicated on the plans. The midship section plan to be supplied on board the ship is to include the minimum allowable hull girder sectional properties for hold transverse section in all cargo holds),
- previous repair history,
- cargo and ballast history,
- inspections by ship's personnel with reference to:
 - structural deterioration in general,
 - leakage in bulkheads and piping,
 - condition of coating or corrosion prevention system, if any,

- a guidance for reporting is shown in Table III,
- any other information that will help identify critical structural areas and/or Suspect Areas requiring inspection.

6.3.2 For tankers and bulk carriers subject to SOLAS, Chapter II-1, Part A-1, Reg. 3-10, the Ship Construction File (SCF), limited to the items to be retained on board, is to be available on board.

6.4 REVIEW OF DOCUMENTATION ON BOARD

6.4.1 Prior to inspection, the Surveyor is to examine the completeness of the documentation onboard, and its contents as a basis for the survey.

6.4.2 For tankers and bulk carriers subject to SOLAS, Chapter II-1, Part A-1, Reg. 3-10, on completion of the survey, the surveyor is to verify that the update of the Ship Construction File (SCF) has been done whenever a modification of the documentation included in the SCF has taken place.

6.4.2.1 For the SCF stored on board ship, the surveyor is to examine the information on board ship. In cases where any major event, including, but not limited to, substantial repair and conversion, or any modification to the ship structures, the surveyor is to also verify that the updated information is kept on board the ship. If the updating of the SCF onboard is not completed at the time of survey, the Surveyor records it and requires confirmation at the next periodical survey.

6.4.2.2 For the SCF stored on shore archive, the surveyor is to examine the list of information included on shore archive. In cases where any major event, including, but not limited to, substantial repair and conversion, or any modification to the ship structures, the surveyor is to also verify that the updated information is stored on shore archive by examining the list of information included on shore archive or kept on board the ship. In addition, the surveyor is to confirm that the service contract with the Archive Center is valid. If the updating of the SCF Supplement ashore is not completed at the time of survey, the Surveyor records it and requires confirmation at the next periodical survey.

6.4.3 For tankers and bulk carriers subject to SOLAS, Chapter II-1, Part A-1, Reg. 3-10, on completion of the survey, the surveyor is to verify any addition and/or renewal of materials used for the construction of the hull structure are documented within the Ship Construction File inventory list.

7 PROCEDURES FOR THICKNESS MEASUREMENTS

7.1 GENERAL

7.1.1 The required thickness measurements, if not carried out by the *Register* itself, are to be witnessed by a Surveyor of the *Register*. The Surveyor is to be on board to the extent necessary to control the process.

7.1.2 The thickness measurement firm is to be part of the survey planning meeting to be held prior to commencing the survey.

7.1.3 Thickness measurements of structures in areas where close-up surveys are required shall be carried out simultaneously with close-up surveys.

7.1.4 In all cases the extent of thickness measurements is to be sufficient as to represent the actual average condition.

7.2 CERTIFICATION OF THICKNESS MEASUREMENTS FIRM

7.2.1 The thickness measurements are to be carried out by a qualified firm certified by the *Rules for the classification of ships, Part 1 - General requirements, Chapter 4 - Approval of manufacturers and service suppliers*.

7.3 NUMBER AND LOCATIONS OF MEASUREMENTS

7.3.1 Application

The item 7.3 only applies to vessels built under the IACS Common Structural Rules IACS Common Struc-

tural Rules* (CSR). For vessels not built under IACS Common Structural Rules, the requirements for number and locations of measurements are according to the Rules of the *Register* and/or specific IACS URs depending on ship's age and structural elements concerned.

* IACS Common Structural Rules mean IACS Common Structural Rules for Bulk Carriers (IACS CSR for Bulk Carriers) or IACS Common Structural Rules for Bulk Carriers and Oil Tankers (IACS CSR BC & OT).

7.3.2 Number of measurements

Considering the extent of thickness measurements according to the different structural elements of the ship and surveys (Renewal, intermediate and annual), the locations of the points to be measured are given for the most important items of the structure.

7.3.3 Locations of measurements

Table 1 provides explanations and/or interpretations for the application of those requirements indicated in the Rules, which refer to both systematic thickness measurements related to the calculation of global hull girder strength and specific measurements connected to close-up surveys.

Fig 4 to Fig 9 are provided to facilitate the explanations and/or interpretations given in Table 1, to show typical arrangements of single side skin bulk carriers.

Table 1
Interpretations of rule requirements for the locations and number of points to be measured for CSR bulk carriers (single skin)

Item	Interpretation	Figure reference
Selected plates on deck, tank top, bottom, double bottom and wind-and- water area	«Selected» means at least a single point on one out of three plates, to be chosen on representative areas of average corrosion	
All deck, tank top and bottom plates and wind-and-water strakes	At least two points on each plate to be taken either at each 1/4 extremity of plate or at representative areas of average corrosion	
Transverse section	A transverse section includes all longitudinal members such as plating, longitudinals and girders at the deck, side, bottom; inner bottom and hopper side plating, longitudinal bulkhead and bottom plating in top wing tanks.	Fig. 4
All cargo hold hatch covers and coamings	Including plates and stiffeners	Locations of points are given in Fig. 5

Item	Interpretation	Figure reference
Transverse section of deck plating outside line of cargo hatch openings	Two single points on each deck plate (to be taken either at each 1/4 extremity of plate or at representative areas of average corrosion) between the ship sides and hatch coamings in the transverse section concerned	
All deck plating and underdeck structure inside line of hatch openings between cargo hold hatches	<p>«All deck plating» means at least two points on each plate to be taken either at each 1/4 extremity of plate or at representative areas of average corrosion.</p> <p>“Under deck structure”: at each short longitudinal girder: three points for web plating (fwd/middle/aft), single point for face plate, one point for web plating and one point for face plating of transverse beam in way. At each ends of transverse beams, one point for web plating and one point for face plating</p>	<p>Extent of areas is shown in Annex D</p> <p>Location of points are given in Fig. 9</p>
Selected side shell frames in cargo holds	<p>Includes side shell frame, upper and lower end attachments and adjacent shell plating.</p> <p>25% of frames: one out of four frames should preferably be chosen throughout the cargo hold length on each side.</p> <p>50% of frames: one out of two frames should preferably be chosen throughout the cargo hold length on each side.</p> <p>«Selected frames» means at least 3 frames on each side of cargo holds</p>	<p>Extent of areas is shown in Annex D</p> <p>Locations of points are given in Fig. 6</p>
Transverse bulkheads in cargo holds	Includes bulkhead plating, stiffeners, and girders, including internal structure of upper and lower stools, where fitted. Two selected bulkheads: one is to be the bulkhead between the two foremost cargo holds and the second may be chosen in other positions	<p>Areas of measurements are shown in Annex D</p> <p>Locations of points are given in Fig. 7</p>
One transverse bulkhead in each cargo hold	This means that the close-up survey and related thickness measurements are to be performed on one side of the bulkhead; the side is to be chosen based on the outcome of the overall survey of both sides. In the event of doubt, the Surveyor may also require (possibly partial) close-up survey on the other side	<p>Areas of measurements are shown in Annex D</p> <p>Locations of points are given in Fig. 7</p>
Transverse bulkheads in one topside, hopper and double bottom ballast tank	<p>Includes bulkhead and stiffening systems.</p> <p>The ballast tank is to be chosen based on the history of ballasting among those prone to have the most severe conditions</p>	Locations of points are given in Fig. 8

Item	Interpretation	Figure reference
Transverse webs in ballast tanks	Includes web plating, face plates, stiffeners and associated plating and longitudinals. One of the representative tanks of each type (i.e. topside or hopper or side tank) is to be chosen in the forward part	Areas of measurements are shown in Annex D Locations of points are given in Fig. 6

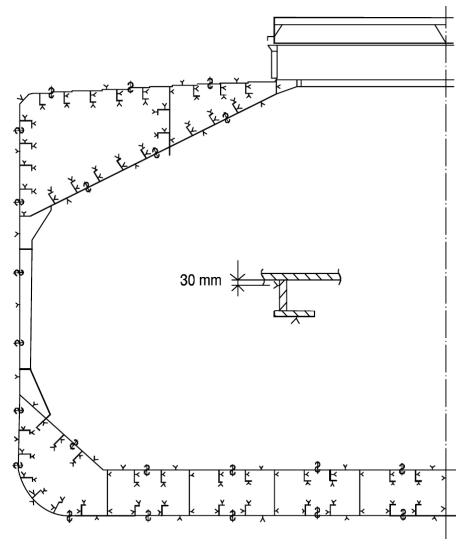

Single side bulk carriers

NOTE: Measurements are to be taken on both port and starboard sides of the selected transverse section.

Figure 4 - Transverse section of a single skin bulk carrier

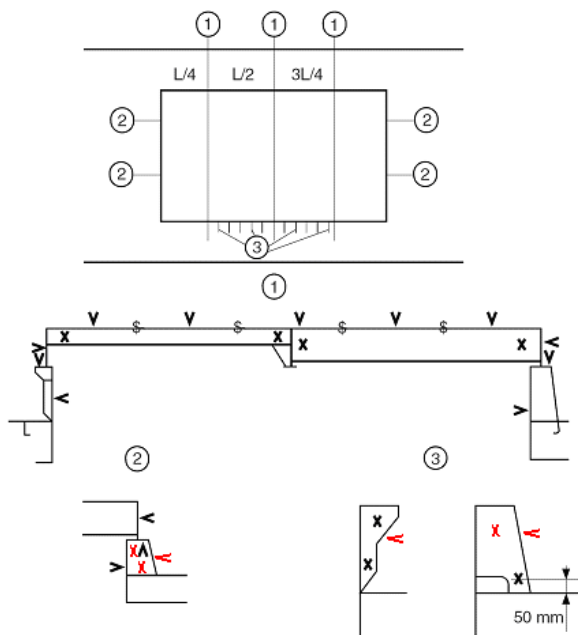

NOTES:

1. Three sections at L/4, L/2, 3L/4 of hatch cover length, including:
 - one measurement of each hatch cover plate and skirt plate
 - measurements of adjacent beams and stiffeners
 - one measurement of coaming plates and coaming flange, each side
2. Measurements of both ends of hatch cover skirt plate, coaming plate and coaming flange
3. One measurement (two points for web plate and one point for face plate) of one out of three hatch coaming brackets and bars, on both sides and both ends

Figure 5 - Locations of measurements on hatch covers and coamings

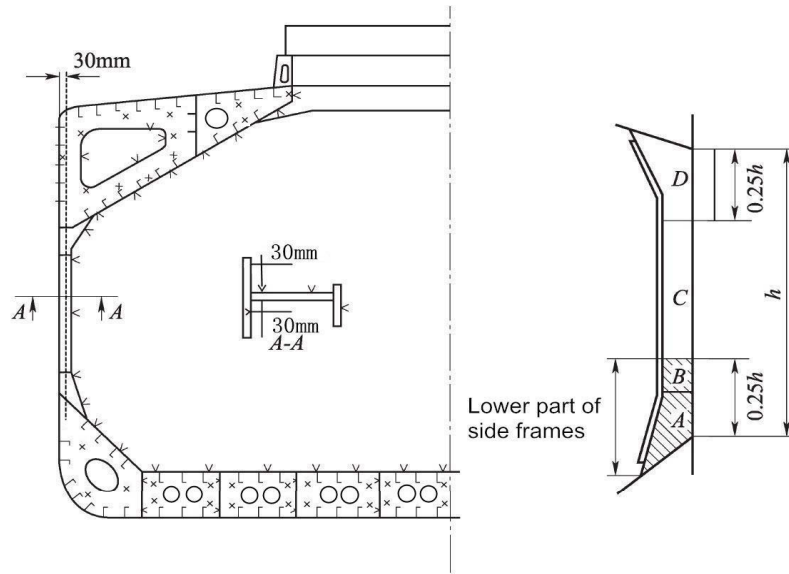

NOTE:

The gauging pattern for web plating is to be a three-point pattern for zones A, C and D, and a two point pattern for zone B (see figure). The gauging report is to reflect the average reading. The average reading is to be compared with the allowable thickness. If the web plating has general corrosion, then this pattern is to be expanded to a five-point pattern.

Figure 6 - Locations of measurements on structural members in cargo holds and ballast tanks of single side skin bulk carriers

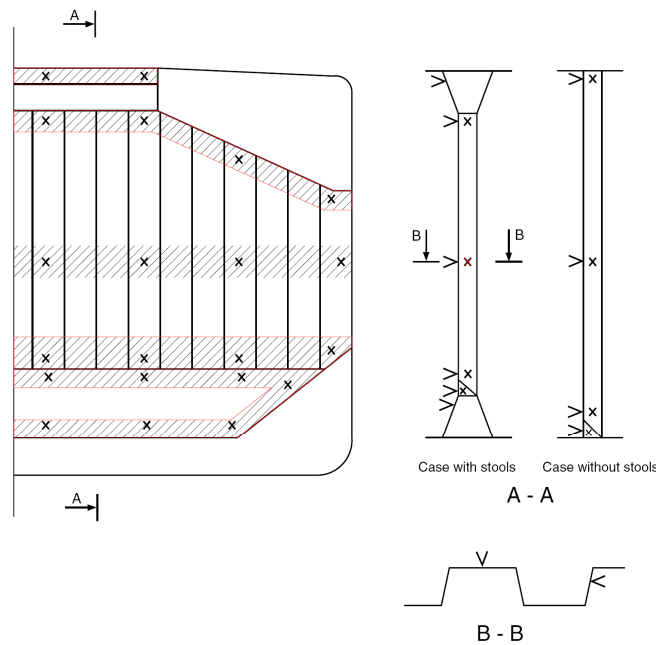

NOTE: Measurements to be taken in each shaded area as per views A - A and B - B

Figure 7 - Locations of measurements on cargo hold transverse bulkheads (additional measurements to internal structure of upper and lower stools to be added, e. g. two points in the upper and two points in the lower stools to be indicated in section A - A)

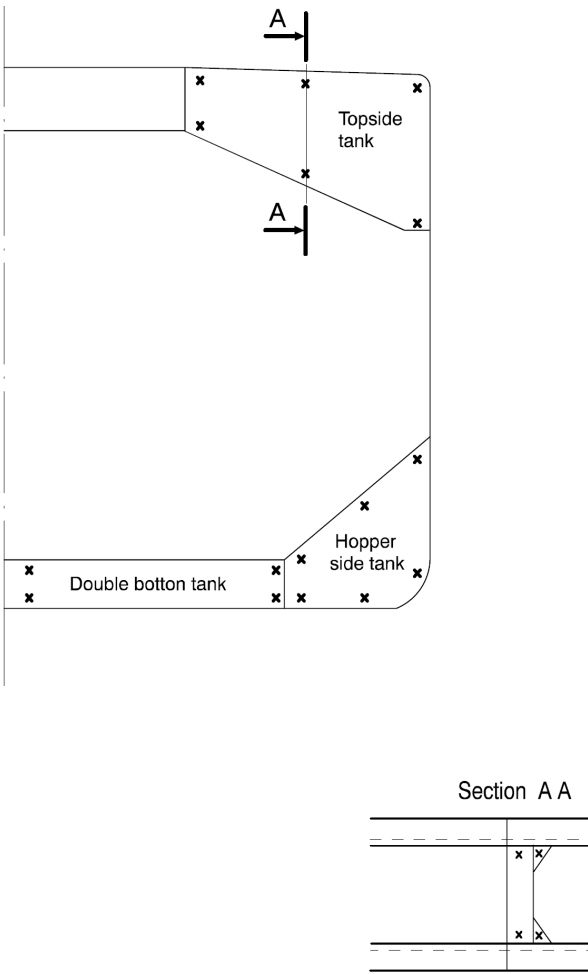

NOTE: Measurements to be taken in each vertical section as per view A - A

Figure 8 - Locations of measurements on transverse bulkheads of topside, hopper and double bottom tanks (two additional measurements to internal structure of double bottom tank to be added at midspan)

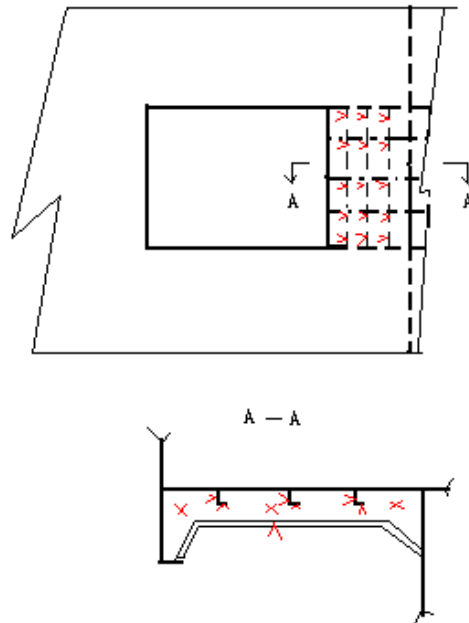

Figure 9 - Locations of measurements on underdeck structure

7.4 REPORTING

7.4.1 A thickness measurement report is to be prepared. The report is to give the location of measurements, the thickness measured as well as corresponding original thickness. Furthermore, the report is to give the date when the measurements were carried out, type of measurement equipment, names of personnel and their qualifications and has to be signed by the operator.

7.4.2 The Surveyor is to review the final thickness measurement report and countersign the cover page.

8 ACCEPTANCE CRITERIA

8.1 GENERAL

8.1.1 For vessels built under IACS Common Structural Rules, the Acceptance Criteria is according to IACS Common Structural Rules* (CSR) and as specified in 8.2, 8.3 and 8.4.

*Ch.13 of IACS CSR for Bulk Carriers, or Ch. 13, Part 1 of IACS CSR BC & OT.

8.1.2 For vessels not built under IACS Common Structural Rules, the Acceptance Criteria are according to the Rules of the *Register* and/or specific IACS URs depending on ship's age and structural elements concerned, e.g. UR S18 for corrugated transverse watertight bulkheads, UR S19 for the transverse watertight corrugated bulkhead between Cargo Holds Nos. 1 and 2, and URS21 for all cargo hatch covers and hatch forward and side coamings on exposed decks in position 1 (as defined in ILLC), UR S31 for side shell frames, as applicable.

8.2 ACCEPTANCE CRITERIA FOR PITTING CORROSION OF CSR SHIPS

8.2.1 Side structures

If pitting intensity in an area where coating is required, according to IACS Common Structural Rules* (CSR), is higher than 15% (see Figure 1), thickness measurements are to be performed to check the extent of pitting corrosion. The 15% is based on pitting or grooving on only one side of a plate.

* Sec. 5, Ch. 3 of IACS CSR for Bulk Carriers, or Sec. 4, Ch. 3, Part 1 of IACS CSR BC & OT

In cases where pitting is exceeding 15%, as defined above, an area of 300 mm or more, at the most pitted part of the plate, is to be cleaned to bare metal and the thickness is to be measured in way of the five deepest pits within the cleaned area. The least thickness measured in way of any of these pits is to be taken as the thickness to be recorded.

The minimum remaining thickness in pits, grooves or other local areas is to be greater than the following without being greater than the renewal thickness (t_{ren}):

- 75% of the as-built thickness, in the frame and end brackets webs and flanges
- 70% of the as-built thickness, in the side shell, hopper tank and topside tank plating attached to the each side frame, over a width up to 30 mm from each side of it.

8.2.2 Other structures

For plates with pitting intensity less than 20%, see Figure 1, the measured thickness, t_m of any individual measurement is to meet the lesser of the following criteria:

$$t_m \geq 0.7 (t_{as-built} - t_{vol\ add}) \text{ mm}$$

$$t_m \geq t_{ren} - 1 \text{ mm}$$

where:

$t_{as-built}$ As-built thickness of the member, in mm

$t_{vol\ add}$ Voluntary thickness addition; thickness, in mm, voluntarily added as the Owner's extra margin for corrosion wastage in addition to t_c

t_{ren} Renewal thickness; minimum allowable thickness, in mm, below which renewal of structural members is to be carried out

t_c Total corrosion addition, in mm, defined in IACS Common Structural Rules* (CSR)

t_m Measured thickness, in mm, on one item, i.e. average thickness on one item using the various measurements taken on this same item during periodical ship's in service surveys.

* Sec. 3, Ch. 3 of IACS CSR for Bulk Carriers, or Sec. 3, Ch. 3, Part 1 of IACS CSR BC & OT.

The average thickness across any cross section in the plating is not to be less than the renewal criteria for general corrosion given in IACS Common Structural Rules*.

* Ch.13 of IACS CSR for Bulk Carriers, or Ch. 13, Part 1 of IACS CSR BC & OT.

8.3 ACCEPTANCE CRITERIA FOR EDGE CORROSION OF CSR SHIPS

8.3.1 Provided that the overall corroded height of the edge corrosion of the flange, or web in the case of flat bar stiffeners, is less than 25%, see Figure 2, of the stiffener flange breadth or web height, as applicable, the measured thickness, t_m , is to meet the lesser of the following criteria:

$$t_m \geq 0.7 (t_{as-built} - t_{vol\ add}) \text{ mm}$$

$$t_m \geq t_{ren} - 1 \text{ mm}$$

8.3.2 The average measured thickness across the breadth or height of the stiffener is not to be less than that defined in IACS Common Structural Rules* (CSR).

* Ch.13 of IACS CSR for Bulk Carriers, or Ch. 13, Part 1 of IACS CSR BC & OT.

8.3.3 Plate edges at openings for manholes, lightening holes etc. may be below the minimum thickness given in IACS Common Structural Rules* (CSR) provided that:

- a) the maximum extent of the reduced plate thickness, below the minimum given in IACS Common Structural Rules* (CSR), from the opening edge is not more than 20% of the smallest dimension of the opening and does not exceed 100mm.
- b) rough or uneven edges may be cropped-back provided that the maximum dimension of the opening is not increased by more than 10% and the remaining thickness of the new edge is not less than $t_{ren} - 1$ mm.

* Ch.13 of IACS CSR for Bulk Carriers, or Ch. 13, Part 1 of IACS CSR BC & OT.

8.4 ACCEPTANCE CRITERIA FOR GROOVING CORROSION OF CSR SHIPS

8.4.1 Where the groove breadth is a maximum of 15% of the web height, but not more than 30 mm, see Figure 3, the measured thickness, t_m , in the grooved area is to meet the lesser of the following criteria:

$$t_m \geq 0.75 (t_{as-built} - t_{vol add}) \text{ mm}$$

$$t_m \geq t_{ren} - 0.5 \text{ mm}$$

but is not to be less than:

$$t_m = 6 \text{ mm}$$

8.4.2 Structural members with areas of grooving greater than those in 8.4.1 above are to be assessed based on the criteria for general corrosion as defined in IACS Common Structural Rules* (CSR) using the average measured thickness across the plating/stiffener.

* Ch.13 of IACS CSR for Bulk Carriers, or Ch. 13, Part 1 of IACS CSR BC & OT.

9 REPORTING AND EVALUATION OF SURVEY

9.1 EVALUATION OF SURVEY REPORT

9.1.1 The data and information on the structural condition of the vessel collected during the survey is to be evaluated for acceptability and continued structural integrity of the vessel.

9.1.1.1 For CSR bulk carriers, the ship's longitudinal strength is to be evaluated by using the thickness of structural members measured, renewed and reinforced, as appropriate, during the Renewal surveys carried out after the ship reached 15 years of age (or during the Renewal survey no. 3, if this is carried out before the ship reaches 15 years) in accordance with the criteria for longitudinal strength of the ship's hull girder for CSR bulk carriers specified in IACS Common Structural Rules* (CSR).

* Ch.13 of IACS CSR for Bulk Carriers, or Ch. 13, Part 1 of IACS CSR BC & OT.

9.1.1.2 The final result of evaluation of the ship's longitudinal strength required in 9.1.1.1, after renewal or reinforcement work of structural members, if carried out as a result of initial evaluation, is to be reported as a part of the Executive Hull Summary.

9.2 REPORTING

9.2.1 Principles for survey reporting are shown in the Table VI of IACS UR Z10.2.

9.2.2 When a survey is split between different survey stations, a report is to be made for each portion of the survey. A list of item examined and / or tested (pressure testing, thickness measurements etc.) and an indication of whether the item has been credited, are to be made available to the next attending Surveyor(s), prior to continuing or completing the survey.

9.2.3 An Executive Hull Summary of the survey and results is to be issued to the Owner as shown in table VII of IACS UR Z10.2 and placed on board the vessel for reference at future surveys. The Executive Hull Summary is to be endorsed by the Head Office of the *Register*.

Table I
TABLE OF MINIMUM REQUIREMENT FOR CLOSE-UP SURVEY AT RENEWAL HULL SURVEYS OF BULK CARRIERS

I Renewal survey (age ≤ 5)	II Renewal survey (5 < age ≤ 10)	III Renewal survey (10 < age ≤ 15)	IV Renewal survey and all subsequent surveys (age > 15)
<p>(A) 25 % of shell frames in the forward cargo hold at representative positions.</p> <p>(A) Selected frames in remaining cargo holds.</p> <p>(B) One transverse web with associated plating and longitudinals in two representative water ballast tanks of each type (i.e. topside, or hopper side tank).</p>	<p>(A) All shall frames in the forward cargo hold and 25% of shell frames in each of the remaining cargo holds including upper and lower end attachments and adjacent shell plating.</p> <p>For Bulk Carriers 100.000 DWT and above, all shall frames in the forward cargo hold and 50% of shell frames in each of the remaining cargo holds including upper and lower end attachments and adjacent shell plating</p> <p>(B) One transverse web with associated plating and longitudinals in each water ballast tank.</p> <p>(B) Forward and aft transverse bulkhead in one ballast tank, including stiffening system.</p>	<p>(A) All shell frames in the forward and one other selected cargo hold and 50 % of frames in remaining cargo holds, including upper and lower end attachments and adjacent shell plating.</p> <p>(B) All transverse webs with associated plating and longitudinals in each water ballast tank.</p> <p>(B) All transverse bulkheads in ballast tanks, including stiffening system.</p>	<p>(A) All frames in all cargo holds, including upper and lower end attachments and adjacent shell plating.</p> <p>Areas (B) - (E) as for Renewal survey No. III</p>

I Renewal survey (age ≤ 5)	II Renewal survey (5 < age ≤ 10)	III Renewal survey (10 < age ≤ 15)	IV Renewal survey and all subsequent surveys (age > 15)
<p>(C) Two selected cargo hold transverse bulkheads, including internal structure of upper and lower stools, where fitted.</p> <p>(D) All cargo hold hatch covers and coamings (plating and stiffeners)</p>	<p>(C) All cargo hold transverse bulkheads, including internal structure of upper and lower stools, where fitted.</p> <p>(D) All cargo hold hatch covers and coamings (plating and stiffeners)</p> <p>(E) All deck plating and under deck structure inside line of hatch openings between all cargo hold hatches.</p>	<p>Areas (C), (D) and (E) as for Renewal survey No. II</p>	
<p>Cargo hold transverse frames:</p> <p>(A): Transverse web frame or watertight transverse bulkhead in water ballast tanks</p> <p>(B): Cargo hold transverse bulkheads plating, stiffeners and girders</p> <p>(C): Cargo hold hatch covers and coamings. Subject to cargo hold hatch covers of approved design which structurally have no access to the internals, close-up survey shall be done of accessible parts of hatch covers structures.</p> <p>(D): Deck plating and under deck structure inside line of hatch openings between cargo hold hatches</p> <p>See sketches in Annex D for areas corresponding to (A), (B), (C), (D) and (E)</p> <p>Zones of side shell frames for ships are as required for compliance with UR S31</p> <p>NOTES:</p> <p>Close-up survey of transverse bulkheads is to be carried out at four levels:</p> <p>Level (a) – immediately above the inner bottom and immediately above the line of gussets (if fitted) and shedders for ships without stool</p> <p>Level (b) – immediately above and below the lower stool shell plate (for those ships fitted with lower stools), and immediately above the line of the shedder plates</p> <p>Level (c) – about mid-height of the bulkhead</p> <p>Level (d) – immediately below the upper deck plating and immediately adjacent to the upper wing tank, and immediately below the upper stool shelf plate for those ships fitted with upper stools, or immediately below the topside tanks</p>			

Table II
MINIMUM REQUIREMENTS FOR THICKNESS MEASUREMENTS AT RENEWAL HULL SURVEY OF BULK CARRIERS

I Renewal survey (age ≤ 5)	II Renewal survey (5 < age ≤ 10)	III Renewal survey (10 < age ≤ 15)	IV Renewal survey and all subsequent surveys (age > 15)
<p>1. Suspect areas.</p>	<p>1. Suspect areas.</p> <p>2. Within the cargo length:</p> <p>a) two transverse sections of deck plating outside line of cargo hatch openings</p> <p>3. Wind and water strakes in way of the transverse sections considered above. Selected wind and water strakes outside the cargo length area</p> <p>4. Measurement, for general assessment and recording of corrosion pattern, of those structural members, subject to Close-up survey according to Table I</p> <p>5. Additional thickness measurement guidelines applicable to the side shell frames and brackets on ships subject to compliance with UR S31</p>	<p>1. Suspect areas.</p> <p>2. Within the cargo length:</p> <p>a) each deck plate outside line of cargo hatch openings</p> <p>b) two transverse sections, one in the amidship area outside line of cargo hatch opening</p> <p>c) all wind and water strakes</p> <p>3. Selected wind and water strakes outside the cargo length area</p> <p>4. Measurement, for general assessment and recording of corrosion pattern, of those structural members, subject to Close-up survey according to Table I</p> <p>5. Additional thickness measurement guidelines applicable to the vertically corrugated transverse watertight bulkhead between cargo hold Nos. 1 and 2 on ships subject to compliance with UR S19 and S23. Guidance is contained in the <i>Rules for the classification of ships, Part 2 – Hull, Annex A.</i></p> <p>6. Additional thickness measurement guidelines applicable to the side shell frames and brackets on ships subject to compliance with UR S31</p>	<p>1. Suspect areas.</p> <p>2. Within the cargo length:</p> <p>a) each deck plate outside line of cargo hatch openings</p> <p>b) three transverse sections, one in the amidship area, outside line of cargo hatch opening</p> <p>c) each bottom plate</p> <p>3. All wind and water strakes, full length</p> <p>4. Measurement, for general assessment and recording of corrosion pattern, of those structural members, subject to Close-up survey according to Table I</p> <p>5. Additional thickness measurement guidelines applicable to the vertically corrugated transverse watertight bulkhead between cargo hold Nos. 1 and 2 on ships subject to compliance with UR S19 and S23. Guidance is contained in the <i>Rules for the classification of ships, Part 2 – Hull, Annex A.</i></p> <p>6. Additional thickness measurement guidelines applicable to the side shell frames and brackets on ships subject to compliance with UR S31</p>

TABLE III

Ship Name:						
OWNERS INSPECTION REPORT - Structural Condition						
For Tank/Hold No:						
Grade of Steel:		Deck	:	Side	:	
		Bottom	:	Long. Bhd	:	
Elements	Cracks	Buckles	Corrosion	Coating cond.	Pitting	Mod. /Rep.
Other						
Deck:						
Bottom:						
Side:						
Long. Bulkheads:						
Transv. Bulkheads:						
Repairs carried out due to:						
Thickness measurements carried out, dates:						
Results in General:						
Overdue Surveys:						
Outstanding Conditions of class:						
Comments:						
*Repairs are to be surveyed by the classification society						
Date of Inspection:						
Inspected by: _____						
Signature: _____						

Table IV, Sheet 1
REQUIREMENTS FOR EXTENT OF THICKNESS MEASUREMENT AT THOSE AREAS OF
SUBSTANTIAL CORROSION
RENEWAL SURVEY OF BULK CARRIERS WITHIN THE CARGO AREA

SHELL STRUCTURES		
Structural member	Extent of measurement	Pattern of measurement
<i>Bottom and side shell plating</i>	a) Suspect plate, plus 4 adjacent plates b) See other tables for particulars on gauging in way tanks and cargo holds	a) 5-point pattern for each panel between longitudinals
<i>Bottom / side shell longitudinals</i>	Minimum of 3 longitudinals in way of suspect areas	3 measurements in line across web 3 measurements on flange

Table IV, Sheet 2
REQUIREMENTS FOR EXTENT OF THICKNESS MEASUREMENT AT THOSE AREAS OF
SUBSTANTIAL CORROSION
RENEWAL SURVEY OF BULK CARRIERS WITHIN THE CARGO AREA

TRANSVERSE BULKHEADS IN CARGO HOLDS		
Structural member	Extent of measurement	Pattern of measurement
<i>Lower stool</i>	a) Transverse band within 25 [mm] of welded connection to inner bottom b) Transverse band within 25 [mm] of welded connection to shelf plate	a) 5-point between stiffeners over 1 metre length b) Ditto
<i>Transverse bulkhead</i>	a) Transverse band at approximately mid height b) Transverse band at part of bulkhead adjacent to upper deck or below upper stool shelf plate (for those ships fitted with upper stools)	a) 5-point pattern over 1 square meter of plating b) 5-point pattern over 1 square meter of plating

Table IV, Sheet 3
REQUIREMENTS FOR EXTENT OF THICKNESS MEASUREMENT AT THOSE AREAS OF
SUBSTANTIAL CORROSION
RENEWAL SURVEY OF BULK CARRIERS WITHIN THE CARGO AREA

DECK STRUCTURE INCLUDING CROSS STRIPS, MAIN CARGO HATCHWAYS, HATCH COVERS, COAMINGS AND TOPSIDE TANKS		
Structural member	Extent of measurement	Pattern of measurement
<i>Cross deck strip plating</i>	Suspect cross deck strip plating	a) 5-point pattern between underdeck stiffeners over 1 metre length
<i>Underdeck stiffeners</i>	a) Transverse members b) Longitudinal members	a) 5-point pattern at each end and mid span b) 5-point pattern on both web and flange
<i>Hatch covers</i>	a) Side and end skirts, each 3 locations b) 3 longitudinal bands, outboard strakes (2) and centreline strake (1)	a) 5-point pattern at each location b) 5-point measurement each band
<i>Hatch coamings</i>	Each side and end coaming, one band lower 1/3, one band upper 2/3 of coaming	5-point measurement each band i.e. end or side coaming
<i>Topside water ballast tanks</i>	a) Watertight transverse bulkheads: - lower 1/3 of bulkhead - upper 2/3 of bulkhead - stiffeners b) 2 representative swash transverse bulkheads: - lower 1/3 of bulkhead - upper 2/3 of bulkhead - stiffeners c) 3 representative bays of slope plating: - lower 1/3 of tank - upper 2/3 of tank d) Longitudinals, suspect and adjacent	a) Watertight transverse bulkheads: - 5-point pattern over 1 square metre of plating - 5-point pattern over 1 square metre of plating - 5-point pattern over 1 metre of length b) 2 representative swash transverse bulkheads: - 5-point pattern over 1 square metre of plating - 5-point pattern over 1 square metre of plating - 5-point pattern over 1 metre of length c) 3 representative bays of slope plating: - 5-point pattern over 1 square metre of plating - 5-point pattern over 1 square metre of plating d) 5-point pattern both web and flange over 1 metre length.
<i>Main deck plating</i>	Suspect plates and adjacent (4)	5-point pattern over 1 square metre of plating
<i>Main deck longitudinals</i>	Minimum of 3 longitudinals where plating measured	5-point pattern on both web and flange over 1 metre length
<i>Web Frames / transverses</i>	Suspect plates	5-point pattern over 1 square metre

Table IV, Sheet 4
REQUIREMENTS FOR EXTENT OF THICKNESS MEASUREMENT AT THOSE AREAS OF SUBSTANTIAL CORROSION
RENEWAL SURVEY OF BULK CARRIERS WITHIN THE CARGO AREA

DOUBLE BOTTOM AND HOPPER STRUCTURE		
Structural member	Extent of measurement	Pattern of measurement
<i>Inner / double bottom plating</i>	Suspect plate plus all adjacent plates	5-point pattern for each panel between longitudinals over 1 metre length
<i>Inner / double bottom longitudinals</i>	Three longitudinals where plates measured	+ 3 measurements in line across web and 3 measurements on flange
<i>Longitudinal Girders or Transverse Floors</i>	Suspect plates	5-point pattern over about 1 square metre
<i>Watertight bulkheads (watertight floors)</i>	a) Lower 1/3 of tank b) Upper 2/3 of tank	a) 5-point pattern over 1 square metre of plating b) 5-point pattern alternate plates over 1 square metre of plating
<i>Web frames</i>	Suspect plate	5-point pattern over 1 square metre of plating
<i>Bottom/side shell longitudinals</i>	Minimum of 3 longitudinals in way of suspect areas.	3 measurements in line across web 3 measurements on flange

Table IV, Sheet 5
REQUIREMENTS FOR EXTENT OF THICKNESS MEASUREMENT AT THOSE AREAS OF SUBSTANTIAL CORROSION
RENEWAL SURVEY OF BULK CARRIERS WITHIN THE CARGO AREA

CARGO HOLDS		
Structural member	Extent of measurement	Pattern of measurement
<i>Side shell frames</i>	Suspect frame and each adjacent	a) At each end and mid span: 5-point pattern of both web and flange b) 5-point pattern within 25 [mm] of welded attachment to both shell and lower slope plate

ANNEX C
Hull Surveys of Double Skin Bulk Carriers

Annex C **HULL SURVEYS OF DOUBLE SKIN BULK CARRIERS**

Contents:

	Page
1 GENERAL.....	1
1.1 APPLICATION	1
1.2 DEFINITIONS	1
1.3 REPAIRS.....	4
1.4 THICKNESS MEASUREMENTS AND CLOSE-UP SURVEYS.....	4
2 RENEWAL (SPECIAL) SURVEY	5
2.1 SCHEDULE	5
2.2 SCOPE.....	5
2.3 EXTENT OF OVERALL AND CLOSE-UP SURVEYS.....	6
2.4 EXTENT OF THICKNESS MEASUREMENTS.....	6
2.5 EXTENT OF TANK TESTING	7
2.6 ADDITIONAL RENEWAL SURVEY REQUIREMENTS AFTER DETERMINING COMPLIANCE WITH SOLAS XII/12 AND XII/13.....	7
3 ANNUAL SURVEY	8
3.1 SCHEDULE	8
3.2 SCOPE.....	8
3.3 ADDITIONAL ANNUAL SURVEY REQUIREMENTS AFTER DETERMINING COMPLIANCE WITH SOLAS XII/12 AND XII/13.....	9
3.4 EXAMINATION OF DOUBLE-SIDE SKIN VOID SPACES FOR BULK CARRIERS EXCEEDING 20 YEARS OF AGE AND OF 150 M IN LENGTH AND UPWARDS	9
4 INTERMEDIATE SURVEY	10
4.1 SCHEDULE	10
4.2 SCOPE.....	10
5 PREPARATION FOR SURVEY	12
5.1 SURVEY PROGRAMME.....	12
5.2 CONDITIONS FOR SURVEY	12
5.3 ACCESS TO STRUCTURES.....	12
5.4 EQUIPMENT FOR SURVEY.....	13
5.5 RESCUE AND EMERGENCY RESPONSE EQUIPMENT	13
5.6 SURVEY AT SEA OR AT ANCHORAGE	13
5.7 SURVEY PLANNING MEETING	14
6 DOCUMENTATION ON BOARD	15
6.1 GENERAL.....	15
6.2 SURVEY REPORT FILE.....	15
6.3 SUPPORTING DOCUMENTS	15
6.4 REVIEW OF DOCUMENTATION ON BOARD	15
7 PROCEDURES FOR THICKNESS MEASUREMENTS	16
7.1 GENERAL.....	16
7.2 CERTIFICATION OF THICKNESS MEASUREMENTS FIRM.....	16
7.3 NUMBER AND LOCATIONS OF MEASUREMENTS	16
7.4 REPORTING.....	20
8 ACCEPTANCE CRITERIA.....	21
8.1 GENERAL.....	21
8.2 ACCEPTANCE CRITERIA FOR PITTING CORROSION OF CSR SHIPS.....	21
8.3 ACCEPTANCE CRITERIA FOR EDGE CORROSION OF CSR SHIPS.....	21
8.4 ACCEPTANCE CRITERIA FOR GROOVING CORROSION OF CSR SHIPS	22
9 REPORTING AND EVALUATION OF SURVEY.....	23
9.1 EVALUATION OF SURVEY REPORT	23
9.2 REPORTING.....	23

1 GENERAL

1.1 APPLICATION

1.1.1 The requirements apply to all self-propelled Double Skin Bulk Carriers.

1.1.2 For bulk carriers with hybrid cargo hold arrangements, e.g. with some cargo holds of single side skin and others of double side skin, the requirements for single skin bulk carrier are to apply to cargo holds of single side skin.

1.1.3 The requirements apply to surveys of hull structure and piping systems in way of cargo holds, cofferdams, pipe tunnels, void spaces within the cargo length area and all ballast tanks. The requirements are additional to the classification requirements applicable to the remainder of the ship. Refer to subtitles 4.2, 5.2 and 7.2 in the *Rules for the classification of ships, Part 1 - General requirements, Chapter 5 - Surveys of ships in service*.

1.1.4 The requirements contain the minimum extent of examination, thickness measurements and tank testing. The survey is to be extended when Substantial Corrosion and/or structural defects are found and include additional close-up survey when necessary.

1.2 DEFINITIONS

1.2.1 Double Skin Bulk Carrier

A Double Skin Bulk Carrier is a ship which is constructed with a single deck, double bottom topside tanks and hopper side tanks in cargo spaces, and is intended primarily to carry dry cargo in bulk including such types as ore carriers and combination carriers¹⁾ in which all cargo holds are bounded by a double-side skin (regardless of the width of the wing space). Ore and combination carriers are not covered by the IACS Common Structural Rules.

1.2.2 Ballast Tank

A Ballast Tank is a tank which is used primarily for salt water ballast, or, where applicable, a space which is used for both cargo and salt water ballast will be treated as a Ballast tank when substantial corrosion has been found in that space. A Double Side Tank is to be considered as a separate tank even if it is in connection to either the topside tank or the hopper side tank.

1.2.3 Spaces

Spaces are separate compartments including holds, tanks, cofferdams and void spaces bounding cargo holds, decks and the outer hull.

1.2.4 Overall Survey

An Overall Survey is a survey intended to report on the overall condition of the hull structure and determine the extent of additional close-up surveys.

1.2.5 Close-up Survey

A Close-up Survey is a survey where the details of structural components are within the close visual inspection range of the Surveyor, i.e. normally within reach of hand.

1.2.6 Transverse Section

A Transverse Section includes all longitudinal members such as plating, longitudinals and girders at the deck, sides, bottom, inner bottom, hopper sides, inner sides top wing inner sides and longitudinal bulkheads. For transversely framed vessels, a transverse section includes adjacent frames and their end connections in way of transverse sections.

1.2.7 Representative Spaces

Representative Spaces are those which are expected to reflect the condition of other spaces of similar type and service and with similar corrosion prevention systems. When selecting Representative Spaces account is to be taken of the service and repair history onboard and identifiable Critical Structural Areas and/or Suspect Areas.

1.2.8 Suspect Areas

Suspect Areas are locations showing Substantial Corrosion and/or are considered by the Surveyor to be prone to rapid wastage.

1.2.9 Critical Structural Areas

Critical Structural Areas are locations which have been identified from calculations to require monitoring or from the service history of the subject ship or from similar or sister ships (if available) to be sensitive to cracking, buckling or corrosion which would impair the structural integrity of the ship.

1.2.10 Renewal Thickness

Renewal thickness (t_{ren}) is the minimum allowable thickness, in mm, below which renewal of structural members is to be carried out.

1.2.11 Substantial Corrosion

Substantial Corrosion is an extent of corrosion such that assessment of corrosion pattern, indicate a wastage in excess of 75% of allowable margins, but within acceptable limits.

For vessels built under the IACS Common Structural Rules, substantial corrosion is an extent of corrosion such that the assessment of the corrosion pattern indicates a gauged (or measured) thickness between $t_{net} + 0.5$ mm and t_{net} .

1.2.12 Corrosion Prevention System

A Corrosion Prevention System is normally considered a full hard coating.

Hard Protective Coating is usually to be epoxy coating or equivalent. Other coating systems, which are neither soft nor semi-hard coatings, may be considered acceptable as alternatives provided that they are applied and maintained in compliance with the manufacturer's specification.

¹⁾ For combination carriers with longitudinal bulkheads additional requirements are specified in IACS UR Z10.1 or UR Z10.4, as applicable.

1.2.13 Coating condition

Coating condition is defined as follows:

GOOD - condition with only minor spot rusting,

FAIR - condition with local breakdown at edges of stiffeners and weld connections and/or light rusting over 20% or more of areas under consideration, but less than as defined for POOR condition,

POOR - condition with general breakdown of coating over 20% or more of areas or hard scale at 10% or more of areas under consideration.

1.2.14 Cargo Length Area

Cargo Length Area is that part of the ship which contains all cargo holds and adjacent areas including fuel tanks, cofferdams, ballast tanks and void spaces.

1.2.15 Special consideration

Special consideration or specially considered (in connection with close-up surveys and thickness measurements) means sufficient close-up inspection and thickness measurements are to be taken to confirm the actual average condition of the structure under the coating.

1.2.16 Prompt and Thorough Repair

A Prompt and Thorough Repair is a permanent repair completed at the time of survey to the satisfaction of the Surveyor, therein removing the need for the imposition of any associated condition of class.

1.2.17 Pitting Corrosion

Pitting corrosion is defined as scattered corrosion spots/areas with local material reductions which are greater than the general corrosion in the surrounding area. Pitting intensity is defined in Figure 1.

1.2.18 Edge Corrosion

Edge corrosion is defined as local corrosion at the free edges of plates, stiffeners, primary support members and around openings. An example of edge corrosion is shown in Figure 2.

1.2.19 Grooving Corrosion

Grooving corrosion is typically local material loss adjacent to weld joints along abutting stiffeners and at stiffener or plate butts or seams. An example of groove corrosion is shown in Figure 3.

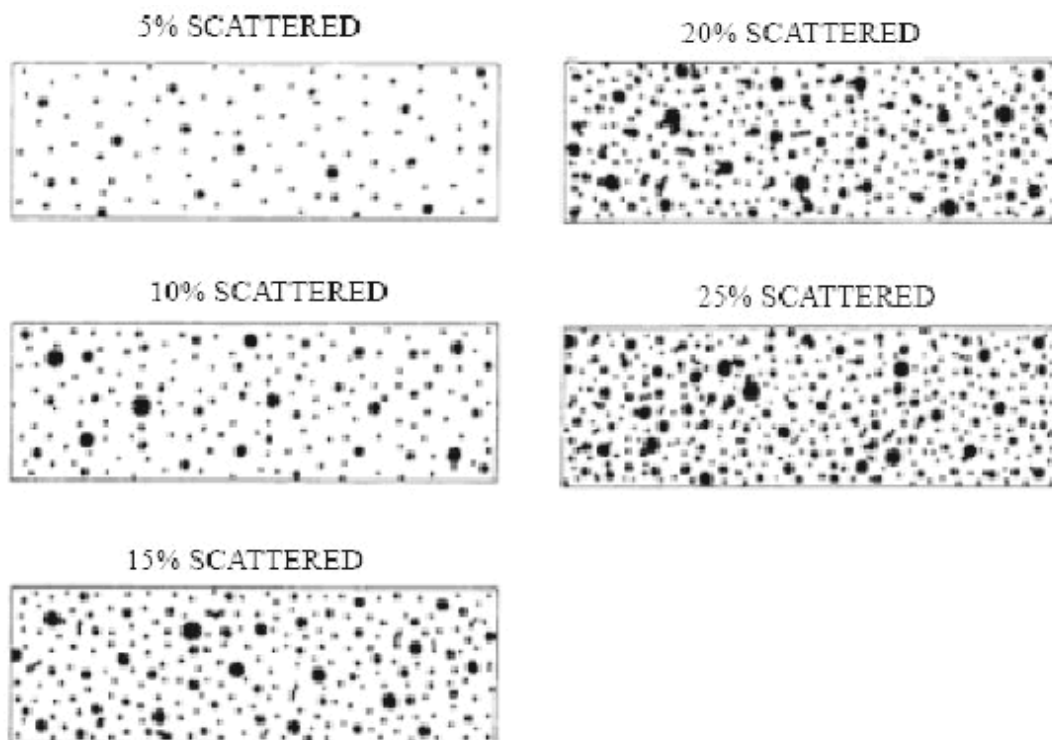

Figure 1 - Pitting intensity diagrams

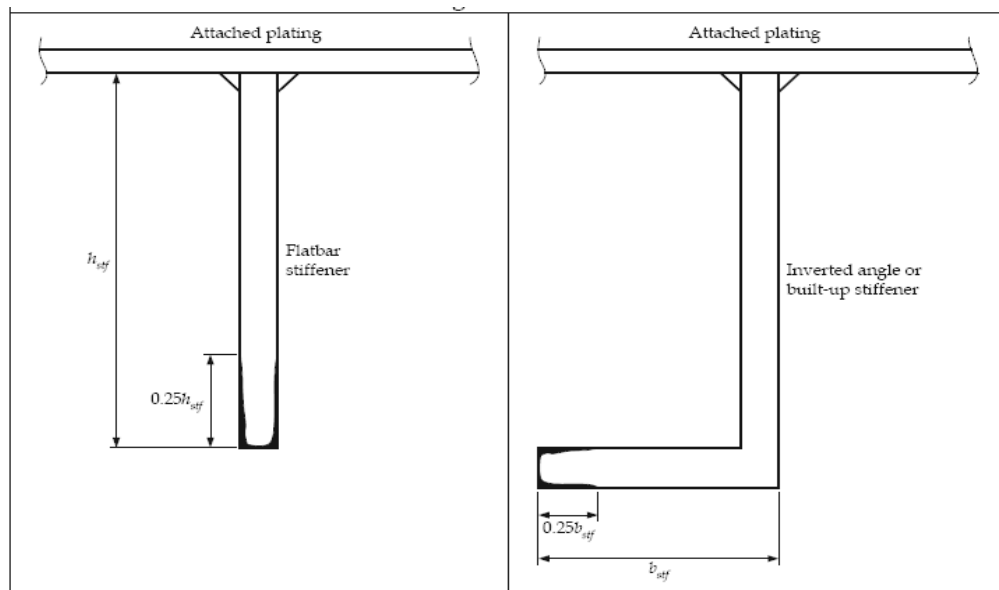

Figure 2 - Edge corrosion

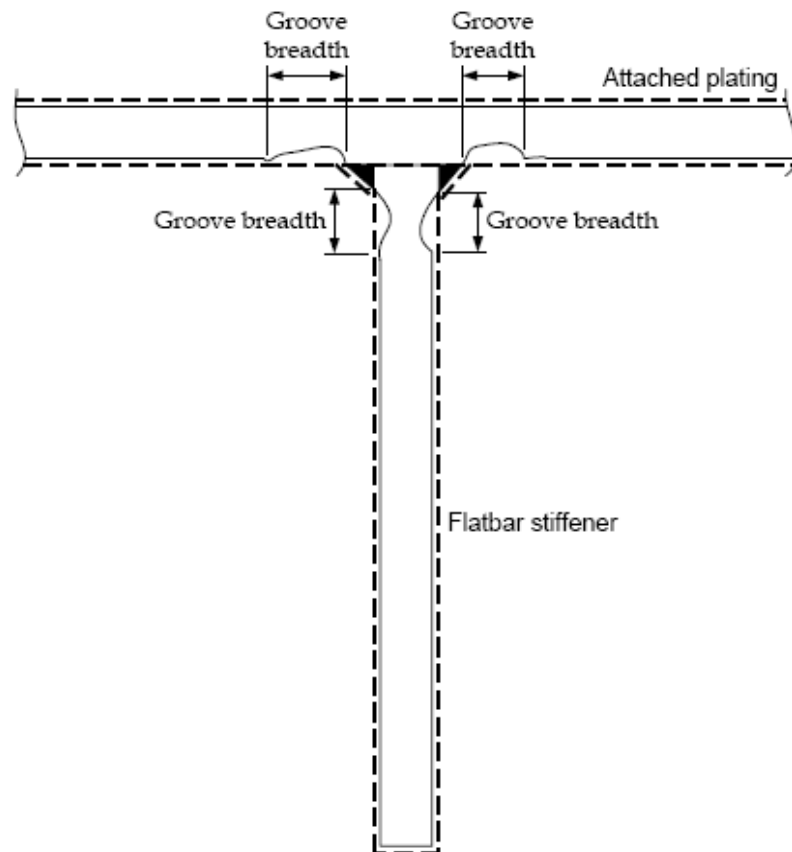

Figure 3 - Grooving corrosion

1.3 REPAIRS

1.3.1 Any damage in association with wastage over the allowable limits (including buckling, grooving, detachment or fracture), or extensive areas of wastage over the allowable limits, which affects or, in the opinion of the Surveyor, will affect the vessel's structural, watertight or weathertight integrity, is to be promptly and thoroughly (see 1.2.15) repaired.

Areas to be considered include:

- bottom structure and bottom plating;
- side structure and side plating;
- deck structure and deck plating;
- inner bottom structure and inner bottom plating;
- inner side structure and inner side plating
- watertight or oiltight bulkheads;
- hatch covers and hatch coamings;
- items in 3.2.3.6.

For locations where adequate repair facilities are not available, consideration may be given to allow the vessel to proceed directly to a repair facility. This may require discharging the cargo and/or temporary repairs for the intended voyage.

1.3.2 Additionally, when a survey results in the identification of structural defects or corrosion, either of which, in the opinion of the Surveyor, will impair the vessel's fitness for continued service, remedial measures are to be implemented before the ship continues in service.

1.3.3 Where the damage found on structure mentioned in item 1.3.1 is isolated and of a localised nature which does not affect the ship's structural integrity, consideration may be given by the surveyor to allow an appropriate temporary repair to restore watertight or weather tight integrity and impose a condition of class in accordance with IACS PR 35, with a specific time limit.

1.4 THICKNESS MEASUREMENTS AND CLOSE-UP SURVEYS

1.4.1 In any kind of survey, i.e. Renewal, intermediate, annual or other surveys having the scope of the foregoing ones, thickness measurements, when required by Table II, of structures in areas where close-up surveys are required shall be carried out simultaneously with close-up surveys.

2 RENEWAL (SPECIAL) SURVEY

2.1 SCHEDULE

2.1.1 Renewal surveys are to be carried out at 5 years intervals to renew the Certificate of Class.

2.1.2 The first Renewal survey is to be completed within 5 years from the date of the initial survey and thereafter within 5 years from the credited date of the previous Renewal survey. However, an extension of class of 3 months maximum beyond the 5th year can be granted in exceptional circumstances.

In this case, the next period of class will start from the expiry date of the Renewal survey before the extension was granted.

2.1.3 For surveys completed within 3 months before the expiry date of the Renewal survey, the next period of validity of certificate will start from the expiry date of the Renewal survey. For surveys completed more than 3 months before the expiry date of the Renewal survey, the period of validity of certificate will start from the survey completion date. In cases where the vessel has been laid up or has been out of service for a considerable period because of a major repair or modification and the owner elects to only carry out the overdue surveys, the next period of class will start from the expiry date of the Renewal survey. If the owner elects to carry out the next due Renewal survey, the period of class will start from the survey completion date.

2.1.4 The Renewal survey may be commenced at the 4th annual survey and be progressed with a view to completion by the 5th anniversary date. When the Renewal survey is commenced prior to the 4th Annual survey, the entire survey is to be completed within 15 months if such work is to be credited to the Renewal survey.

2.1.5 Concurrent crediting to both Intermediate survey and Renewal survey for surveys and thickness measurements of spaces are not acceptable.

2.2 SCOPE

2.2.1 General

2.2.1.1 The Renewal survey is to include, in addition to the requirements of the annual survey, examination, tests and checks of sufficient extent to ensure that the hull and related piping, as required in 2.2.1.3, is in a satisfactory condition and is fit for its intended purpose for the new period of class of 5 years to be assigned, subject to proper maintenance and operation and to periodical surveys being carried out at the due dates.

2.2.1.2 All cargo holds, ballast tanks, including double bottom and double side tanks, pipe tunnels, cofferdams and void spaces bounding cargo holds, decks and outer hull are to be examined, and this examination is to be supplemented by thickness measurement and testing as required in 2.4 and 2.5, to ensure that the structural integrity remains effective. The aim of the examination is to discover Substantial Corrosion,

significant deformation, fractures, damages or other structural deterioration, that may be present.

2.2.1.3 All piping systems within the above spaces are to be examined and operationally tested to working pressure to attending Surveyor's satisfaction to ensure that tightness and condition remain satisfactory.

2.2.1.4 The survey extent of ballast tanks converted to void spaces is to be specially considered in relation to the requirements for ballast tanks.

2.2.2 Dry Dock Survey

2.2.2.1 A survey in dry dock is to be a part of the Renewal survey. The overall and close-up surveys and thickness measurements, as applicable, of the lower portions of the cargo holds and ballast tanks are to be carried out in accordance with the applicable requirements for Renewal surveys, if not already performed.

NOTE: Lower portions of the cargo holds and ballast tanks are considered to be the parts below light ballast water line.

2.2.3 Space Protection

2.2.3.1 Where provided, the condition of the corrosion prevention system of ballast tanks is to be examined. For ballast tanks, excluding double bottom tanks, where the protective coating is found to be in less than GOOD condition, and it is not renewed, where soft or semi-hard coating has been applied, or where a protective coating has not been applied from the time of construction, the tanks in question are to be examined at annual intervals. Thickness measurements are to be carried out as deemed necessary by the Surveyor.

When such a breakdown of coating is found in water ballast double bottom tanks and it is not renewed, where a soft or semi-hard coating is applied, or where the Protective Coating has not been applied from the time of construction, the tanks in question may be examined at annual intervals. When considered necessary by the Surveyor, or where extensive corrosion exists, thickness measurements are to be carried out.

2.2.3.2 Where a hard protective coating is provided in cargo holds and is found in GOOD condition, the extent of close-up surveys and thickness measurements may be specially considered.

2.2.3.3 For double-side skin void spaces bounding cargo holds for bulk carriers exceeding 20 years of age and of 150 meters in length and upwards, where provided, the condition of the corrosion prevention system of void spaces shall be examined. Where a hard protective coating is found to be in POOR condition, and it is not renewed, or where a soft or semi-hard coating has been applied, or where a hard protective coating has not been applied from the time of construction, the void spaces in question shall be examined at annual intervals. Thickness measurements shall be carried out as deemed necessary by the Surveyor.

2.2.4 Hatch Covers and Coamings

The hatch covers and coamings are to be surveyed as follows:

2.2.4.1 A thorough inspection of the items listed in 3.2.3 is to be carried out, in addition to all hatch covers and coamings.

2.2.4.2 Checking of the satisfactory operation of all mechanically operated hatch covers is to be made, including:

- .1 stowage and securing in open condition;
- .2 proper fit and efficiency of sealing in closed condition;
- .3 operational testing of hydraulic and power components, wires, chains, and link drives.

2.2.4.3 Checking the effectiveness of sealing arrangements of all hatch covers by hose testing or equivalent.

2.2.4.4 Close-up survey and thickness measurement of the hatch cover and coaming plating and stiffeners is to be carried out as given in Table I and Table II. Subject to cargo hold hatch covers of approved design which structurally have no access to the internals, close-up survey shall be done of accessible parts of hatch covers structures.

2.3 EXTENT OF OVERALL AND CLOSE-UP SURVEYS

2.3.1 An overall survey of all tanks and spaces is to be carried out at each Renewal survey. Fuel oil tanks in the cargo length area are to be surveyed as follows:

I Renewal survey (age ≤ 5)	II Renewal survey (5 < age ≤ 10)	III Renewal survey (10 < age ≤ 15)	IV Renewal survey and subsequent (age > 15)
None	One	Two	Half, minimum Two
NOTES:			
(1) These requirements apply to tanks of integral (structural) type.			
(2) If a selection of tanks is accepted to be examined, then different tanks are to be examined at each Renewal survey, on a rotational basis.			
(3) Peak tanks (all uses) are subject to internal examination at each Renewal survey.			
(4) At Renewal survey no 3 and subsequent surveys, one deep tank for fuel oil in the cargo area is to be included if fitted.			

2.3.2 The minimum requirements for close-up surveys at Renewal surveys are given in Table I/Sheet 1 for double skin bulk carriers, excluding ore carriers and in Table I/Sheet 2 for ore carriers, respectively.

2.3.3 The Surveyor may extend the close-up survey as deemed necessary taking into account the maintenance of the spaces under survey, the condition of the corrosion prevention system and where spaces have structural arrangements or details which have suffered defects in similar spaces or on similar ships according to available information.

2.3.4 For areas in spaces where coatings are found to be in a GOOD condition, the extent of close-up surveys according to Table I may be specially considered by the *Registrar*, refer also to 2.2.3.2.

2.4 EXTENT OF THICKNESS MEASUREMENTS

2.4.1 The minimum requirements for thickness measurements at Renewal surveys are given in Table II.

2.4.2 Provisions for extended measurements for areas with Substantial Corrosion are given in Table IV and as may be additionally specified in the Survey Programme as required by 5.1. These extended thickness measurements are to be carried out before the survey is credited as completed. Suspect Areas identified at previous surveys are to be examined. Areas of substantial corrosion identified at previous surveys are to have thickness measurements taken.

For vessels built under IACS Common Structural Rules, the identified substantial corrosion areas may be:

- a) protected by coating applied in accordance with the coating manufacturer's requirements and examined at annual intervals to confirm the coating in way is still in good condition, or alternatively;
- b) required to be measured at annual intervals.

2.4.3 The Surveyor may further extend the thickness measurements as deemed necessary.

2.4.4 For areas in tanks where hard protective coatings are found to be in a GOOD condition, the extent of thickness measurements according to Table II may be specially considered. Refer also to 2.2.3.2.

2.4.5 Transverse sections are to be chosen where the largest reductions are suspected to occur or are revealed from deck plating measurements, one of which is to be in the amidships area.

2.4.6 Representative thickness measurement to determine both general and local levels of corrosion in the transverse web frames in all water ballast tanks is to be carried out. Thickness measurement is also to be carried out to determine the corrosion levels on the transverse bulkhead plating. The extent of thickness measurements may be specially considered provided the surveyor is satisfied by the close-up survey, that there is no structural diminution, and the hard protective coating where applied remains efficient.

2.5 EXTENT OF TANK TESTING

2.5.1 All boundaries of water ballast tanks, deep tanks and cargo holds used for water ballast within the cargo length area are to be pressure tested. For Fuel Oil Tanks, only representative tanks are to be pressure tested.

2.5.2 The Surveyor may extend the tank testing as deemed necessary.

2.5.3 Boundaries of ballast tanks are to be tested with a head of liquid to the top of air pipes.

2.5.4 Boundaries of ballast holds are to be tested with a head of liquid to near to the top of hatches.

2.5.5 Boundaries of fuel oil tanks are to be tested with a head of liquid to the highest point that liquid will rise under service conditions. Tank testing of fuel oil tanks may be specially considered based on a satisfactory external examination of the tank boundaries, and a confirmation from the Master stating that the pressure testing has been carried out according to the requirements with satisfactory results.

2.5.6 The testing of double bottom tanks and other spaces not designed for the carriage of liquid may be omitted, provided a satisfactory internal examination together with an examination of the tank top is carried out.

2.6 ADDITIONAL RENEWAL SURVEY REQUIREMENTS AFTER DETERMINING COMPLIANCE WITH SOLAS XII/12 AND XII/13

2.6.1 For ships complying with the requirements of SOLAS XII/12 for hold, ballast and dry space water level detectors, the Renewal survey is to include an examination and a test of the water ingress detection systems and of their alarms.

2.6.2 For ships complying with the requirements of SOLAS XII/13 for the availability of pumping systems, the Renewal survey is to include an examination and a test of the means for draining and pumping ballast tanks forward of the collision bulkhead and bilges of dry spaces any part of which extends forward of the foremost cargo hold, and of their controls.

3 ANNUAL SURVEY

3.1 SCHEDULE

3.1.1 Annual Surveys are to be held within 3 months before or after the anniversary date from the date of the initial classification survey or of the date credited for the last Renewal survey.

3.2 SCOPE

3.2.1 General

3.2.1.1 The survey is to consist of an examination for the purpose of ensuring, as far as practicable, that the hull, hatch covers, coamings and piping are maintained in a satisfactory condition and should take into account the service history, condition and extent of the corrosion prevention system of ballast tanks and areas identified in the survey report file.

3.2.2 Examination of the hull

3.2.2.1 Examination of the hull plating and its closing appliances as far as can be seen.

3.2.2.2 Examination of watertight penetrations as far as practicable.

3.2.3 Examination of weather decks, hatch covers and coamings

3.2.3.1 Confirmation is to be obtained that no unapproved changes have been made to the hatch covers, hatch coamings and their securing and sealing devices since the last survey.

3.2.3.2 A thorough survey of cargo hatch covers and coamings is only possible by examination in the open as well as closed positions and is to include verification of proper opening and closing operation. As a result, the hatch cover sets within the forward 25% of the ship's length and at least one additional set, such that all sets on the ship are assessed at least once in every 5-year period, are to be surveyed open, closed and in operation to the full extent on each direction at each annual survey, including:

- .1 stowage and securing in open condition;
- .2 proper fit and efficiency of sealing in closed condition; and
- .3 operational testing of hydraulic and power components, wires, chains, and link drives.

The closing of the covers is to include the fastening of all peripheral, and cross joint cleats or other securing devices. Particular attention is to be paid to the condition of the hatch covers in the forward 25% of the ship's length, where sea loads are normally greatest.

3.2.3.3 If there are indications of difficulty in operating and securing hatch covers, additional sets above those required by 3.2.3.2, at the discretion of the surveyor, are to be tested in operation.

3.2.3.4 Where the cargo hatch securing system does not function properly, repairs are to be carried out under the supervision of the *Register*. Where hatch covers or coamings

undergo substantial repairs, the strength of securing devices should be upgraded to comply with S21.5 of UR S21.

3.2.3.5 For each cargo hatch cover set, at each annual survey, the following items are to be surveyed:

- .1 cover panels, including side plates, and stiffener attachments that may be accessible in the open position by close-up survey (for corrosion, cracks, deformation);
- .2 sealing arrangements of perimeter and cross joints (gaskets for condition and permanent deformation, flexible seals on combination carriers, gasket lips, compression bars, drainage channels and non-return valves);
- .3 clamping devices, retaining bars, cleating (for wastage, adjustment, and condition of rubber components);
- .4 closed cover locating devices (for distortion and attachment);
- .5 chain or rope pulleys;
- .6 guides;
- .7 guide rails and track wheels;
- .8 stoppers;
- .9 wires, chains, tensioners, and gypsies;
- .10 hydraulic system, electrical safety devices and interlocks; and
- .11 end and interpanel hinges, pins and stools where fitted.

3.2.3.6 At each hatchway, at each annual survey, the coamings, with plating, stiffeners and brackets are to be checked for corrosion, cracks and deformation, especially of the coaming tops, including close-up survey.

3.2.3.7 Where considered necessary, the effectiveness of sealing arrangements may be proved by hose or chalk testing supplemented by dimensional measurements of seal compressing components.

3.2.3.8 Where portable covers, wooden or steel pontoons are fitted, checking the satisfactory condition, where applicable, of:

- wooden covers and portable beams, carriers or sockets for the portable beam, and their securing devices;
- steel pontoons, including close-up survey of hatch cover plating;
- tarpaulins;
- cleats, battens and wedges;
- hatch securing bars and their securing devices;
- loading pads/bars and the side plate edge;
- guide plates and chocks;
- compression bars, drainage channels and drain pipes (if any).

3.2.3.9 Examination of flame screens on vents to all bunker tanks.

3.2.3.10 Examination of bunker and vent piping systems, including ventilators.

3.2.4 Examination of Cargo Holds

3.2.4.1 Double Skin Bulk Carriers 10 to 15 years of age. The following is to apply:

- a) Overall survey of two selected cargo

holds.

- b) When considered necessary by the Surveyor, or where extensive corrosion exists, thickness measurement is to be carried out. If the results of these thickness measurements indicate that Substantial Corrosion is found, the extent of thickness measurements is to be increased in accordance with Table IV. These extended thickness measurements are to be carried out before the survey is credited as complete. Suspect Areas identified at previous Renewal surveys are to be examined. Areas of substantial corrosion identified at previous surveys are to have thickness measurements taken.

For vessels built under the IACS Common Structural Rules, the annual thickness gauging may be omitted where a protective coating has been applied in accordance with the coating manufacturer's requirements and is maintained in good condition.

3.2.4.2 Double Skin Bulk Carriers over 15 years of age. The following is to apply:

- a) Overall survey of all cargo holds.
- b) When considered necessary by the Surveyor, or where extensive corrosion exists, thickness measurements are to be carried out. If the results of these thickness measurements indicate that Substantial Corrosion is found, the extent of thickness measurements is to be increased in accordance with Table IV. These extended thickness measurements are to be carried out before the survey is credited as complete. Suspect Areas identified at previous Renewal surveys are to be examined. Areas of substantial corrosion identified at previous surveys are to have thickness measurements taken.
- For vessels built under the IACS Common Structural Rules, the annual thickness gauging may be omitted where a protective coating has been applied in accordance with the coating manufacturer's requirements and is maintained in good condition.
- c) All piping and penetrations in cargo holds, including overboard piping, are to be examined.

3.2.5 Examination of ballast tanks

3.2.5.1 Examination of ballast tanks when required as a consequence of the results of the Renewal survey and Intermediate survey is to be carried out. When considered necessary by the Surveyor, or where extensive corrosion exists, thickness measurement is to be carried out. If the results of these thickness measurements indicate that Substantial Corrosion is found, the extent of thickness measurements is to be increased in accordance with Table IV. These extended thickness measurements are to be carried out before the survey is credited as complete. Suspect Areas identified at previous Renewal surveys are to be examined. Areas of substan-

tial corrosion identified at previous surveys are to have thickness measurements taken.

For vessels built under the IACS Common Structural Rules, the annual thickness gauging may be omitted where a protective coating has been applied in accordance with the coating manufacturer's requirements and is maintained in good condition.

3.3 ADDITIONAL ANNUAL SURVEY REQUIREMENTS AFTER DETERMINING COMPLIANCE WITH SOLAS XII/12 AND XII/13

3.3.1 For ships complying with the requirements of SOLAS XII/12 for hold, ballast and dry space water level detectors, the annual survey is to include an examination and a test, at random, of the water ingress detection systems and of their alarms.

3.3.2 For ships complying with the requirements of SOLAS XII/13 for the availability of pumping systems, the annual survey is to include an examination and a test, of the means for draining and pumping ballast tanks forward of the collision bulkhead and bilges of dry spaces any part of which extends forward of the foremost cargo hold, and of their controls.

3.4 EXAMINATION OF DOUBLE-SIDE SKIN VOID SPACES FOR BULK CARRIERS EXCEEDING 20 YEARS OF AGE AND OF 150 M IN LENGTH AND UPWARDS

Examination of double-side skin void spaces, for bulk carriers exceeding 20 years of age and of 150 meters in length and upwards, are to be carried out when required as a consequence of the results of the renewal survey (as required by 2.2.3.3) and intermediate survey (as required by 4.2.4.1). When considered necessary by the Administration, or when extensive corrosion exists, thickness measurements should be carried out. If the results of these thickness measurements indicate that substantial corrosion is found, the extent of thickness measurements should be increased in accordance with table IV. These extended thickness measurements should be carried out before the survey is credited as completed. Suspect areas identified at previous surveys should be examined. Areas of substantial corrosion identified at previous surveys should have thickness measurements taken.

For bulk carriers built under the IACS Common Structural Rules, the annual thickness gauging may be omitted where a protective coating has been applied in accordance with the coating manufacturer's requirements and is maintained in good condition.

4 INTERMEDIATE SURVEY

4.1 SCHEDULE

4.1.1 The Intermediate Survey is to be held at or between either the 2nd or 3rd annual survey.

4.1.2 Those items, which are additional to the requirements of the annual survey, may be surveyed either at or between the 2nd and 3rd annual survey.

4.1.3 Concurrent crediting to both Intermediate survey and Renewal survey for surveys and thickness measurements of spaces are not acceptable.

4.2 SCOPE

4.2.1 General

4.2.1.1 The survey extent is dependent on the age of the vessel as specified in 4.2.2 to 4.2.4 and shown in Table V.

4.2.2 Double Skin Bulk Carriers 5 - 10 years of age

The following is to apply:

4.2.2.1 Ballast Tanks

- a) For tanks used for water ballast, an overall survey of representative tanks selected by the Surveyor is to be carried out. The selection is to include fore and aft peak tanks and a number of other tanks, taking into account the total number and type of ballast tanks. If such overall survey reveals no visible structural defects, the examination may be limited to verification that the corrosion prevention system remains efficient.
- b) Where a hard coating is found to be in less than GOOD condition, corrosion or other defects are found in water ballast tanks or where a protective coating was not applied from the time of construction, the examination is to be extended to other ballast tanks of the same type.
- c) In ballast tanks other than double bottom tanks, where a protective coating is found to be in less than GOOD condition, and it is not renewed, or where soft or semi-hard coating has been applied, or where a protective coating was not applied from the time of construction, the tanks in question are to be examined and thickness measurements carried out as considered necessary at annual intervals. When such breakdown of coating is found in ballast double bottom tanks, or where a soft or semi-hard coating has been applied, or where a coating has not been applied, the tanks in question may be examined at annual intervals. When considered necessary by the Surveyor, or where extensive corrosion exists, thickness measurements are to be carried out.

- d) In addition to the requirements above, suspect areas identified at previous surveys are to be overall and close-up surveyed.

4.2.2.2 Cargo Holds

- a) An overall survey of all cargo holds is to be carried out.
- b) Where considered necessary by the Surveyor as a result of the overall survey as described in 4.2.2.2a, the survey is to be extended to include a close-up survey of those areas of structure in the cargo holds selected by the Surveyor.

4.2.2.3 Extent of Thickness Measurements

- a) Thickness measurements are to be carried out to an extent sufficient to determine both general and local corrosion levels at areas subject to close-up survey, where required as per 4.2.2.2 b), and as provided in 4.2.2.1 c).
- b) The extent of thickness measurement may be specially considered provided the Surveyor is satisfied by the close-up survey that there is no structural diminution and the hard protective coatings are found to be in a GOOD condition.
- c) Where Substantial Corrosion is found, the extent of thickness measurements is to be increased in accordance with the requirements of Table IV. These extended thickness measurements are to be carried out before the survey is credited as completed. Suspect Areas identified at previous surveys are to be examined. Areas of substantial corrosion identified at previous surveys are to have thickness measurements taken.
For vessels built under IACS Common Structural Rules, the identified substantial corrosion areas may be:
 - protected by coating applied in accordance with the coating manufacturer's requirements and examined at annual intervals to confirm the coating in way is still in good condition, or alternatively;
 - required to be measured at annual intervals.
- d) Where the hard protective coating in cargo holds is found to be in GOOD condition, the extent of close-up surveys and thickness measurements may be specially considered.

EXPLANATORY NOTE: For existing bulk carriers, where owners may elect to coat or re-coat cargo holds as noted above, consideration may be given to the extent of the close-up and thickness measurement surveys. Prior to the coating of cargo holds of existing ships, scantlings are to be ascertained in the presence of a surveyor.

4.2.3 Double Skin Bulk Carriers 10 – 15 years of age

The following is to apply:

4.2.3.1 The requirements of the intermediate survey are to be to the same extent as the previous Renewal survey as required in 5.1. However, internal examination of fuel oil tanks and pressure testing of all tanks are not required unless deemed necessary by the attending Surveyor.

4.2.3.2 In application of 4.2.3.1, the intermediate survey may be commenced at the second annual survey and be progressed during the succeeding year with a view to completion at the third annual survey in lieu of the application of 2.1.4.

4.2.3.3 In application of 4.2.3.1, an underwater survey may be considered in lieu of the requirement of 2.2.2.

4.2.4 Double Skin Bulk Carriers over 15 years of age

The following is to apply:

4.2.4.1 The requirements of the intermediate survey are to be to the same extent as the previous Renewal survey as required in 2 and 5.1.

However, internal examination of fuel oil tanks and pressure testing of all tanks are not required unless deemed necessary by the attending Surveyor.

4.2.4.2 In application of 4.2.4.1, the intermediate survey may be commenced at the second annual survey and be progressed during the succeeding year with a view to completion at the third annual survey in lieu of the application of 2.1.4.

4.2.4.3 In application of 4.2.4.1, a survey in dry dock is to be part of the intermediate survey. The overall and close-up surveys and thickness measurements, as applicable, of the lower portions of the cargo holds and ballast tanks are to be carried out in accordance with the applicable requirements for intermediate surveys, if not already performed.

NOTE: Lower portions of the cargo holds and ballast tanks are considered to be the parts below light ballast water line.

5 PREPARATION FOR SURVEY

5.1 SURVEY PROGRAMME

5.1.1 The Owner in co-operation with the *Register* is to work out a specific Survey Programme prior to the commencement of any part of:

- the Renewal survey;
- the Intermediate Survey for double skin bulk carriers over 10 years of age.

The Survey Programme is to be in a written format. The survey is not to commence until the Survey programme has been agreed.

5.1.1.1. Prior to the development of the survey programme, the survey planning questionnaire is to be completed by the owner and forwarded to the *Register*.

5.1.1.2 The Survey Programme at Intermediate Survey may consist of the Survey Programme at the previous Renewal survey supplemented by the Executive Hull Summary of that Renewal survey and later relevant survey reports.

The Survey Programme is to be worked out taking into account any amendments to the survey requirements implemented after the last Renewal survey carried out.

5.1.2 In developing the survey programme, the following documentation is to be collected and consulted with a view to selecting holds, tanks, areas, and structural elements to be examined:

- survey status and basic ship information,
- documentation on-board, as described in 6.2 and 6.3;
- main structural plans (scantlings drawings), including information regarding use of high tensile steels (HTS);
- relevant previous survey and inspection reports from both the *Register* and the Owner;
- information regarding the use of the ship's holds and tanks, typical cargoes and other relevant data;
- information regarding corrosion prevention level on the new-building;
- information regarding the relevant maintenance level during operation.

5.1.3 The submitted survey programme is to account for and comply, as a minimum, with the requirements of Tables I and II and paragraph 2.5 for close-up survey, thickness measurement and tank testing, respectively, and is to include relevant information including at least:

- basic ship information and particulars;
- main structural plans (scantling drawings), including information regarding use of high tensile steels (HTS);
- plan of holds and tanks;
- list of holds and tanks with information on use, protection and condition of coating;
- conditions for survey (e.g., information regarding hold and tank cleaning, gas

- freeing, ventilation, lighting, etc.);
- provisions and methods for access to structures;
- equipment for surveys;
- nomination of holds and tanks and areas for close-up survey (per 2.3);
- nominations of sections and areas for thickness measurement (per 2.4);
- nomination of tanks for tank testing (per 2.5);
- damage experience related to the ship in question.

5.1.4 The *Register* will advise the Owner of the maximum acceptable structural corrosion diminution levels applicable to the vessel.

5.2 CONDITIONS FOR SURVEY

5.2.1 The Owner is to provide the necessary facilities for a safe execution of the survey.

5.2.1.1 In order to enable the attending surveyors to carry out the survey, provisions for proper and safe access, are to be agreed between the owner and the *Register* and are to be in accordance with IACS PR 37.

5.2.1.2 Details of the means of access are to be provided in the survey planning questionnaire.

5.2.1.3 In cases where the provisions of safety and required access are judged by the attending surveyor(s) not to be adequate, the survey of the spaces involved is not to proceed.

5.2.2 Cargo holds, tanks and spaces are to be safe for access. Cargo holds, tanks and spaces are to be gas free and properly ventilated. Prior to entering a tank, void or enclosed space, it is to be verified that the atmosphere in the tank is free from hazardous gas and contains sufficient oxygen.

5.2.3 In preparation for survey and thickness measurements and to allow for a thorough examination, all spaces are to be cleaned including removal from surfaces of all loose accumulated corrosion scale. Spaces are to be sufficiently clean and free from water, scale, dirt, oil residues etc. to reveal corrosion, deformation, fractures, damages, or other structural deterioration. However, those areas of structure whose renewal has already been decided by the owner need only be cleaned and descaled to the extent necessary to determine the limits of areas to be renewed.

5.2.4 Sufficient illumination is to be provided to reveal corrosion, deformation, fractures, damages, or other structural deterioration as well as the condition of the coating.

5.2.5 Where soft or semi-hard coatings have been applied, safe access is to be provided for the Surveyor to verify the effectiveness of the coating and to carry out an assessment of the conditions of internal structures which may include spot removal of the coating. When safe access cannot be provided, the soft or semi-hard coating is to be removed.

5.3 ACCESS TO STRUCTURES

5.3.1 For overall surveys, means are to be provided to enable the Surveyor to examine the hull structure in a safe and practical way.

5.3.2 For close-up surveys, one or more of the following means for access, acceptable to the Surveyor, is to be provided:

- permanent staging and passages through structures;
- temporary staging, e.g. ladders and passages through structures;
- hydraulic arm vehicles such as conventional cherry pickers, lifts and movable platforms;
- portable ladders;
- boats or rafts;
- other equivalent means.

5.4 EQUIPMENT FOR SURVEY

5.4.1 Thickness measurement is normally to be carried out by means of ultrasonic test equipment. The accuracy of the equipment is to be proven to the Surveyor as required.

5.4.2 One or more of the following fracture detection procedures may be required if deemed necessary by the Surveyor:

- radiographic equipment,
- ultrasonic equipment,
- magnetic particle equipment,
- dye penetrant.

5.4.3 Explosimeter, oxygen-meter, breathing apparatus, lifelines, riding belts with rope and hook and whistles together with instructions and guidance on their use are to be made available during the survey. A safety checklist is to be provided.

5.4.4 Adequate and safe lighting is to be provided for the safe and efficient conduct of the survey.

5.4.5 Adequate protective clothing is to be made available and used (e.g. safety helmet, gloves, safety shoes, etc.) during the survey.

5.5 RESCUE AND EMERGENCY RESPONSE EQUIPMENT

5.5.1 If breathing apparatus and/or other equipment is used as 'Rescue and emergency response equipment' then it is recommended that the equipment should be suitable for the configuration of the space being surveyed.

5.6 SURVEY AT SEA OR AT ANCHORAGE

5.6.1 Survey at sea or at anchorage may be accepted provided the Surveyor is given the necessary assistance from the personnel onboard. Necessary precautions and procedures for carrying out the survey are to be in accordance with 5.1, 5.2, 5.3 and 5.4.

5.6.2 A communication system is to be arranged between the survey party in the spaces under examination and the responsible officer on deck. This system is to also include the personnel in charge of ballast pump handling if boats or rafts are used.

5.6.3 Surveys of tanks or applicable holds by means of boats or rafts may only be undertaken with the agreement

of the Surveyor, who is to take into account the safety arrangements provided, including weather forecasting and ship response under foreseeable conditions and provided the expected rise of water within the tank does not exceed 0.25m.

5.6.4 When rafts or boats are used for close-up surveys, the following conditions are to be observed:

- .1 only rough duty, inflatable rafts or boats, having satisfactory residual buoyancy and stability even if one chamber is ruptured, should be used;
- .2 the boat or raft should be tethered to the access ladder and an additional person should be stationed down the access ladder with a clear view of the boat or raft;
- .3 appropriate lifejackets should be available for all participants;
- .4 the surface of water in the tank should be calm (under all foreseeable conditions the expected rise of water within the tank should not exceed 0.25 m) and the water level either stationary. On no account should the level of the water be rising while the boat or raft is in use;
- .5 the tank or space must contain clean ballast water only. Even a thin sheen of oil on the water is not acceptable;
- .6 at no time should the water level be allowed to be within 1 m of the deepest under deck web face flat so that the survey team is not isolated from a direct escape route to the tank hatch. Filling to levels above the deck transverses should only be contemplated if a deck access manhole is fitted and open in the bay being examined, so that an escape route for the survey party is available at all times. Other effective means of escape to the deck may be considered.

5.6.5 Rafts or boats alone may be allowed for inspection of the underdeck areas for tanks or spaces if the depth of the webs is 1.5 m or less.

5.6.6 If the depth of the webs is more than 1.5 m, rafts or boats alone may be allowed only:

- .1 when the coating of the underdeck structure is in GOOD condition and there is no evidence of wastage; or
- .2 if a permanent means of access is provided in each bay to allow safe entry and exit. This means:
 - i. access direct from the deck via a vertical ladder and a small platform fitted approximately 2 m below the deck in each bay; or
 - ii. access to deck from a longitudinal permanent platform having ladders to deck in each end of the tank. The platform shall, for the full length of the tank, be arranged in level with, or above, the maximum water level needed for rafting of under deck structure. For this purpose, the ullage corresponding to the maximum water level is to be assumed not more than 3

m from the deck plate measured at the midspan of deck transverses and in the middle length of the tank.

If neither of the above conditions are met, then staging or another equivalent means is to be provided for the survey of the underdeck areas.

5.6.7 The use of rafts or boats alone in paragraphs 5.6.5 and 5.6.6 does not preclude the use of boats or rafts to move about within a tank during a survey.

NOTE: Reference is made to IACS Recommendation 39 – Guidelines for use of Boats or Rafts for Close-up Surveys.

5.7 SURVEY PLANNING MEETING

5.7.1 Proper preparation and close co-operation between the attending surveyor(s) and the owner's representatives onboard prior to and during the survey are an essential part in the safe and efficient conduct of the survey. During the survey on board safety meetings are to be held regularly.

5.7.2 Prior to commencement of any part of the renewal and intermediate survey, a survey planning meeting is to be held between the attending surveyor(s), the owner's representative in attendance, the thickness measurement firm representative, where involved, and the master of the ship or an appropriately qualified representative appointed by the master or Company for the purpose to ascertain that all the arrangements envisaged in the survey programme are in place, so as to ensure the safe and efficient conduct of the survey work to be carried out. See also 7.1.2.

5.7.3 The following is an indicative list of items that are to be addressed in the meeting:

- .1 schedule of the vessel (i.e. the voyage, docking and undocking manoeuvres, periods alongside, cargo and ballast operations, etc.);
- .2 provisions and arrangements for thickness measurements (i.e. access, cleaning/de-scaling, illumination, ventilation, personal safety);
- .3 extent of the thickness measurements;
- .4 acceptance criteria (refer to the list of minimum thickness');
- .5 extent of close-up survey and thickness measurement considering the coating condition and suspect areas/areas of substantial corrosion;
- .6 execution of thickness measurements;
- .7 taking representative readings in general and where uneven corrosion/pitting is found;
- .8 mapping of areas of substantial corrosion; and
- .9 communication between attending surveyor(s) the thickness measurement firm operator(s) and owner representative(s) concerning findings.

6 DOCUMENTATION ON BOARD

6.1 GENERAL

6.1.1 The Owner is to supply and maintain on board documentation as specified in 6.2 and 6.3, which is to be readily available for the Surveyor.

6.1.2 The documentation is to be kept on board for the lifetime of the ship.

6.1.3 For ships defined in the *Rules for the classification of ships, Part - General requirements, Chapter 2 - Survey during construction and initial survey*, under the note in item 1.2.2.27, the following is to be applied to surveys commenced on or after 1st July 2016:

For tankers and bulk carriers subject to SOLAS, Chapter II-1, Part A-1, Regulation 3-10, the Owner is to arrange the updating of the Ship Construction File (SCF) throughout the ship's life whenever a modification of the documentation included in the SCF has taken place. Documented procedures for updating the SCF are to be included within the Safety Management System.

6.2 SURVEY REPORT FILE

6.2.1 A Survey Report File is to be a part of the documentation on board consisting of

- reports of structural surveys;
- Executive Hull Summary;
- thickness measurement reports.

6.2.2 The Survey Report File is to be available also in the Owner's and the *Registers* management offices.

6.3 SUPPORTING DOCUMENTS

6.3.1 The following additional documentation is to be available onboard:

- Survey Programme as required by 5.1 until such time as the Renewal Survey or Intermediate Survey, as applicable, has been completed;
- main structural plans of cargo holds and ballast tanks (for CSR ships these plans are to include for each structural element both the as-built and renewal thickness. Any thickness for voluntary addition is also to be clearly indicated on the plans. The midship section plan to be supplied on board the ship is to include the minimum allowable hull girder sectional properties for hold transverse section in all cargo holds;
- previous repair history;
- cargo and ballast history;
- inspections by ship's personnel with reference to:
 - structural deterioration in general;
 - leakage in bulkheads and piping;
 - condition of coating or corrosion prevention system, if any;

- any other information that will help identify Suspect Areas requiring inspection.

6.3.2 For tankers and bulk carriers subject to SOLAS, Chapter II-1, Part A-1, Regulation 3-10, the Ship Construction File (SCF), limited to the items to be retained on board, is to be available on board.

6.4 REVIEW OF DOCUMENTATION ON BOARD

6.4.1 Prior to inspection, the Surveyor is to examine the completeness of the documentation onboard, and its contents as a basis for the survey.

6.4.2 For tankers and bulk carriers subject to SOLAS, Chapter II-1, Part A-1, Regulation 3-10, on completion of the survey, the surveyor is to verify that the update of the Ship Construction File (SCF) has been done whenever a modification of the documentation included in the SCF has taken place.

6.4.2.1 For the SCF stored on board ship, the surveyor is to examine the information on board ship. In cases where any major event, including, but not limited to, substantial repair and conversion, or any modification to the ship structures, the surveyor is to also verify that the updated information is kept on board the ship. If the updating of the SCF onboard is not completed at the time of survey, the Surveyor records it and requires confirmation at the next periodical survey.

6.4.2.2 For the SCF stored on shore archive, the surveyor is to examine the list of information included on shore archive. In cases where any major event, including, but not limited to, substantial repair and conversion, or any modification to the ship structures, the surveyor is to also verify that the updated information is stored on shore archive by examining the list of information included on shore archive or kept on board the ship. In addition, the surveyor is to confirm that the service contract with of the Archive Center is valid. If the updating of the SCF Supplement ashore is not completed at the time of survey, the Surveyor records it and requires confirmation at the next periodical survey.

6.4.3 For tankers and bulk carriers subject to SOLAS, Chapter II-1, Part A-1, Regulation 3-10, on completion of the survey, the surveyor is to verify any addition and/or renewal of materials used for the construction of the hull structure are documented within the Ship Construction File inventory list.

7 PROCEDURES FOR THICKNESS MEASUREMENTS

7.1 GENERAL

7.1.1 The required thickness measurements, if not carried out by the *Register* itself, are to be witnessed by a Surveyor of the *Register*. The Surveyor is to be on board to the extent necessary to control the process.

7.1.2 The thickness measurement firm is to be part of the survey planning meeting to be held prior to commencing the survey.

7.1.3 Thickness measurements of structures in areas where close-up surveys are required shall be carried out simultaneously with close-up surveys.

7.1.4 In all cases the extent of thickness measurements is to be sufficient as to represent the actual average condition.

7.2 CERTIFICATION OF THICKNESS MEASUREMENTS FIRM

7.2.1 The thickness measurements are to be carried out by a qualified firm certified by the *Register* according to principles stated in the *Rules for the classification of ships, Part 1 - General requirements, Chapter 4 - Approval of manufacturers and service suppliers*.

7.3 NUMBER AND LOCATIONS OF MEASUREMENTS

7.3.1 Application

The item 7.3 only applies to vessels built under the IACS Common Structural Rules* (CSR). For vessels not built under IACS Common Structural Rules, the requirements for number and locations of measurements are according to the Rules of the *Register* and/or specific IACS URs depending on ship's age and structural elements concerned.

* IACS Common Structural Rules mean IACS Common Structural Rules for Bulk Carriers (IACS CSR for Bulk Carriers) or IACS Common Structural Rules for Bulk Carriers and Oil Tankers (IACS CSR BC & OT).

7.3.2 Number of measurements

Considering the extent of thickness measurements according to the different structural elements of the ship and surveys (Renewal, intermediate and annual), the locations of the points to be measured are given for the most important items of the structure.

7.3.3 Locations of measurements

Table 1 provides explanations and/or interpretations for the application of those requirements indicated in the Rules, which refer to both systematic thickness measurements related to the calculation of global hull girder strength and specific measurements connected to close-up surveys.

Fig. 4 to Fig. 9 are provided to facilitate the explanations and/or interpretations given in Table 1, to show typical arrangements of double side skin bulk carriers.

Table 1
Interpretations of rule requirements for the locations and number of points to be measured for CSR bulk carriers (double skin)

Item	Interpretation	Figure reference
Selected plates on deck, tank top, bottom, double bottom and wind-and-water area	«Selected» means at least a single point on one out of three plates, to be chosen on representative areas of average corrosion	
All deck, tank top and bottom plates and wind-and-water strakes	At least two points on each plate to be taken either at each 1/4 extremity of plate or at representative areas of average corrosion	
Transverse section	A transverse section includes all longitudinal members such as plating, longitudinals and girders at the deck, sides, bottom, inner bottom, hopper sides, inner sides, and top wing inner sides	Fig 4
All cargo hold hatch covers and coamings	Including plates and stiffeners	Locations of points are given in Fig 5
Transverse section of deck plating outside line of cargo hatch openings	Two single points on each deck plate (to be taken either at each 1/4 extremity of plate or at representative areas of average corrosion) between the ship sides and hatch coamings in the transverse section concerned	

Item	Interpretation	Figure reference
All deck plating and underdeck structure inside line of hatch openings between cargo hold hatches	<p>«All deck plating» means at least two points on each plate to be taken either at each 1/4 extremity of plate or at representative areas of average corrosion.</p> <p>«Under deck structure»: at each short longitudinal girder: three points for web plating (fwd/middle/aft), single point for face plate, one point for web plating and one point for face plating of transverse beam in way. At each ends of transverse beams, one point for web plating and one point for face plating</p>	<p>Extent of areas is shown in Annex D</p> <p>Locations of points are given in Fig 9</p>
Transverse frame in double skin tank		Fig. 4
Transverse bulkheads in cargo holds	Includes bulkhead plating, stiffeners and girders, including internal structure of upper and lower stools, where fitted. Two selected bulkheads: one is to be the bulkhead between the two foremost cargo holds and the second may be chosen in other positions	<p>Areas of measurements are shown in Annex D</p> <p>Locations of points are given in Fig. 7</p>
One transverse bulkhead in each cargo hold	This means that the close-up survey and related thickness measurements are to be performed on one side of the bulkhead; the side is to be chosen based on the outcome of the overall survey of both sides. In the event of doubt, the Surveyor may also require (possibly partial) close-up survey on the other side	<p>Areas of measurements are shown in Annex D</p> <p>Locations of points are given in Fig. 7</p>
Transverse bulkheads in one topside, hopper and double bottom ballast tank	<p>Includes bulkhead and stiffening systems.</p> <p>The ballast tank is to be chosen based on the history of ballasting among those prone to have the most severe conditions</p>	Locations of points are given in Fig. 8
Transverse webs in ballast tanks	<p>Includes web plating, face plates, stiffeners and associated plating and longitudinals.</p> <p>One of the representative tanks of each type (i.e. topside or hopper or side tank) is to be chosen in the forward part</p>	<p>Areas of measurements are shown in Annex D</p> <p>Locations of points are given in Fig. 6</p>

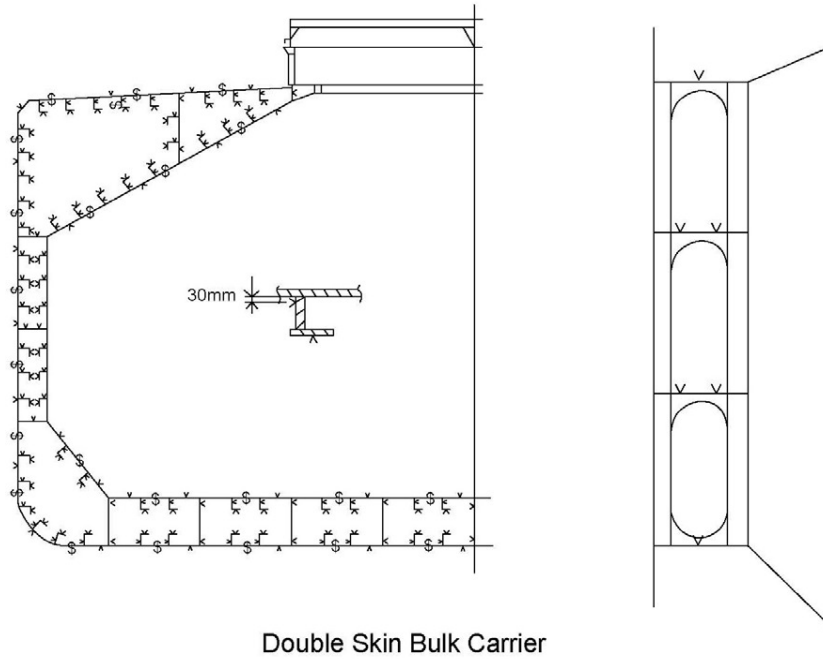

NOTE: Measurements are to be taken on both port and starboard sides of the selected transverse section.

Figure 4 - Transverse section of a double skin bulk carrier

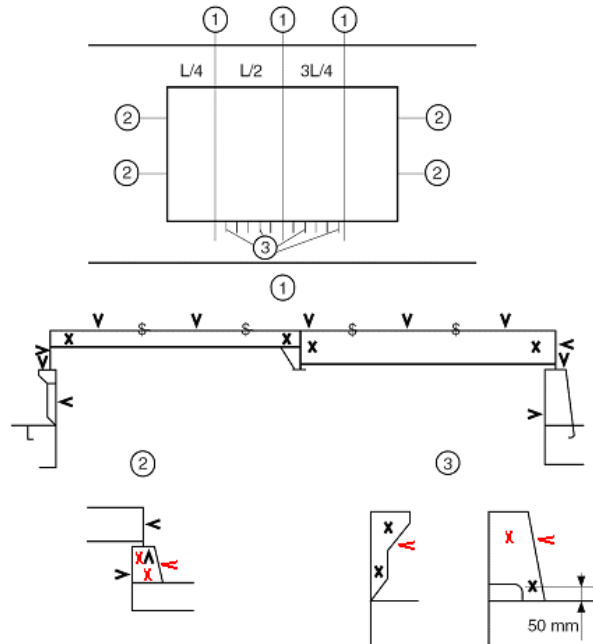

NOTES:

1. Three sections at L/4, L/2, 3L/4 of hatch cover length, including:
 - one measurement of each hatch cover plate and skirt plate
 - measurements of adjacent beams and stiffeners
 - one measurement of coaming plates and coaming flange, each side
2. Measurements of both ends of hatch cover skirt plate, coaming plate and coaming flange
3. One measurement (two points for web plate and one point for face plate) of one out of three hatch coaming brackets and bars, on both sides and both ends

Figure 5 - Locations of measurements on hatch covers and coamings

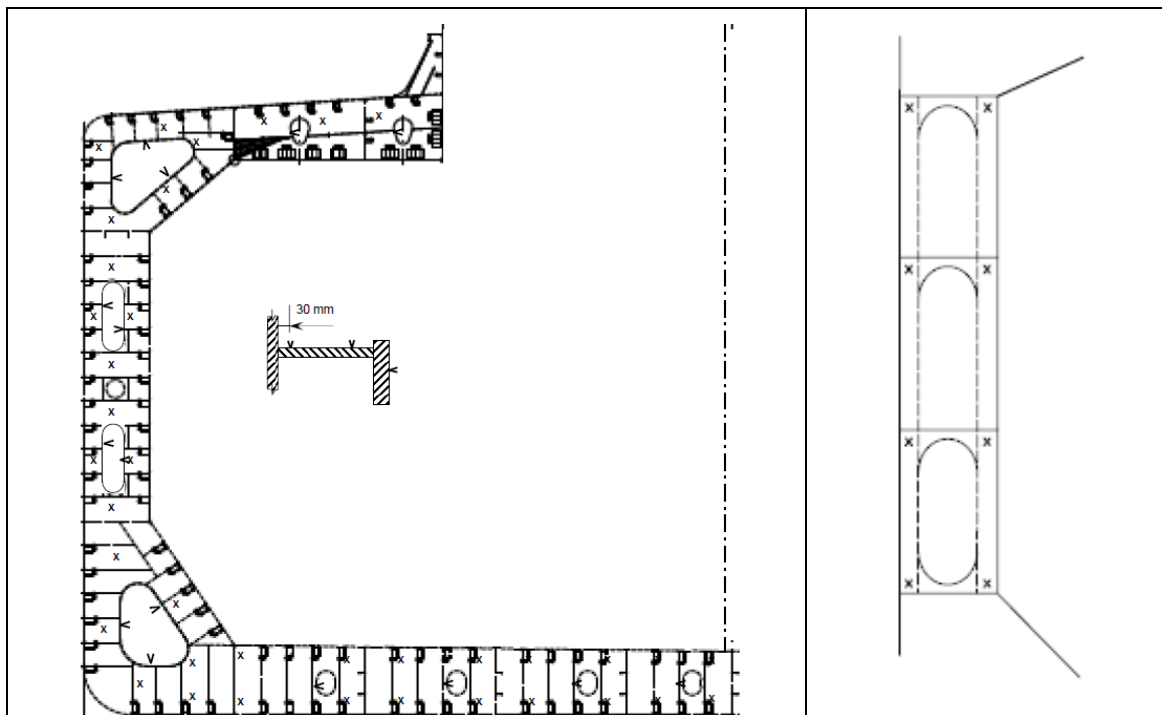
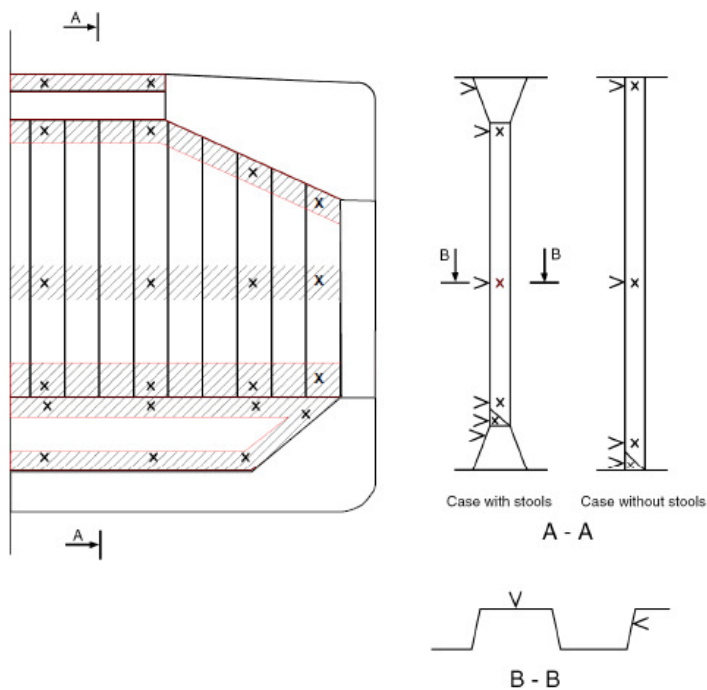
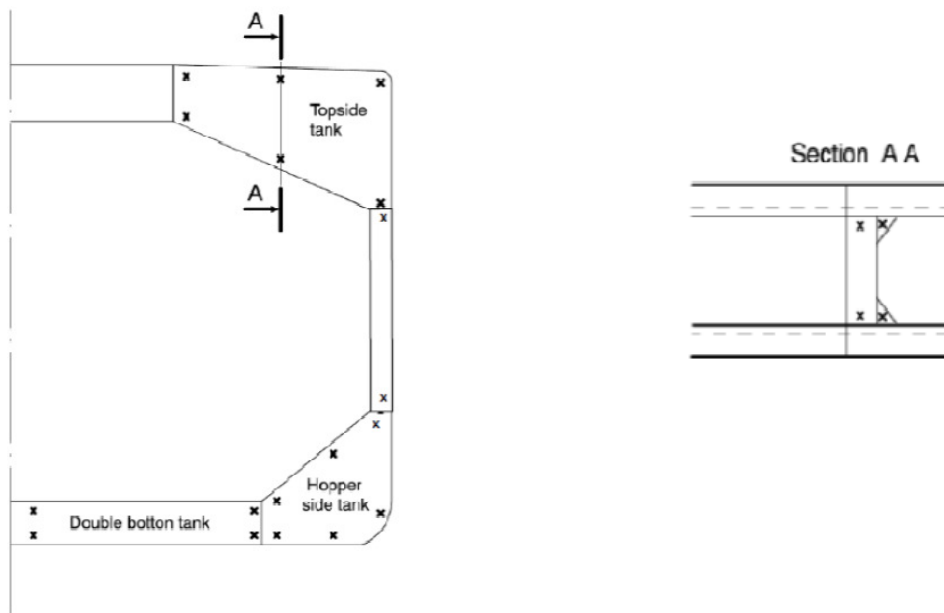

Figure 6 - Locations of measurements on structural members in ballast tanks of double skin bulk carriers (topside or hopper or side tank)



NOTE: Measurements to be taken in each shaded area as per views A - A and B - B

Figure 7 - Locations of measurements on cargo hold transverse bulkheads (additional measurements to internal structure of upper and lower stools to be added, e.g. two points in the upper and two points in the lower stools to be indicated in section A - A)



NOTE: Measurements to be taken in each vertical section as per view A – A

Figure 8 - Locations of measurements on transverse bulkheads of topside, hopper and double bottom tanks (two additional measurements to internal structure of double bottom tank to be added at midspan)

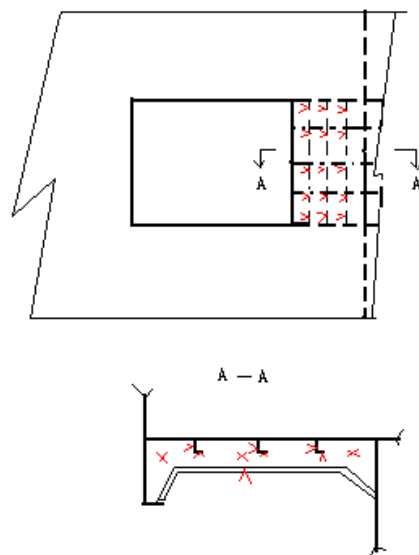

Figure 9 - Locations of measurements on underdeck structure

7.4 REPORTING

7.4.1 A thickness measurement report is to be prepared. The report is to give the location of measurements, the thickness measured as well as corresponding original thickness. Furthermore, the report is to give the date when the measurements were carried out, type of measuring equip-

ment, names of personnel and their qualifications and has to be signed by the operator.

7.4.2 The Surveyor is to review the final thickness measurement report and countersign the cover page.

8 ACCEPTANCE CRITERIA

8.1 GENERAL

8.1.1 For vessels built under IACS Common Structural Rules, the Acceptance Criteria is according to Ch.13 of IACS Common Structural Rules* (CSR) and as specified in 8.2, 8.3 and 8.4.

* Ch.13 of IACS CSR for Bulk Carriers, or Ch. 13, Part 1 of IACS CSR BC & OT.

8.1.2 For vessels not built under IACS Common Structural Rules, the Acceptance Criteria are according to the Rules of the *Register* and/or specific IACS URs depending on ship's age and structural elements concerned, e.g. UR S18 for corrugated transverse watertight bulkheads, UR S19 for the transverse watertight corrugated bulkhead between Cargo Holds Nos. 1 and 2, and UR S21 for all cargo hatch covers and hatch forward and side coamings on exposed decks in position 1 (as defined in ILLC), as applicable.

8.2 ACCEPTANCE CRITERIA FOR PITTING CORROSION OF CSR SHIPS

8.2.1 Side structures

If pitting intensity in an area where coating is required, according to IACS Common Structural Rules* (CSR), is higher than 15% (see Figure 1), thickness measurements are to be performed to check the extent of pitting corrosion. The 15% is based on pitting or grooving on only one side of a plate.

* Sec. 5, Ch. 3 of IACS CSR for Bulk Carriers, or Sec. 4, Ch. 3, Part 1 of IACS CSR BC & OT.

In cases where pitting is exceeding 15%, as defined above, an area of 300 mm or more, at the most pitted part of the plate, is to be cleaned to bare metal and the thickness is to be measured in way of the five deepest pits within the cleaned area. The least thickness measured in way of any of these pits is to be taken as the thickness to be recorded.

The minimum remaining thickness in pits, grooves or other local areas is to be greater than 70% of the as-built thickness, in the side shell, hopper tank and topside tank plating attached to the each side frame, over a width up to 30 mm from each side of it, without being greater than t_{ren} .

8.2.2 Other structures

For plates with pitting intensity less than 20%, see Figure 1, the measured thickness, t_m of any individual measurement is to meet the lesser of the following criteria:

$$t_m \geq 0.7 (t_{as-built} - t_{vol add}) \text{ mm}$$

$$t_m \geq t_{ren} - 1 \text{ mm}$$

where:

$t_{as-built}$ As-built thickness of the member, in mm
 $t_{vol add}$ Voluntary thickness addition; thickness, in mm, voluntarily added as the Owner's extra margin for corrosion wastage in addition to t_c

t_{ren} Renewal thickness; minimum allowable thickness, in mm, below which renewal of structural members is to be carried out
 t_c Total corrosion addition, in mm, defined in Ch. 3, Sec 3 of IACS Common Structural Rules* (CSR)
 t_m Measured thickness, in mm, on one item, i.e. average thickness on one item using the various measurements taken on this same item during periodical ship's in service surveys

* Sec. 3, Ch. 3 of IACS CSR for Bulk Carriers, or Sec. 3, Ch. 3, Part 1 of IACS CSR BC & OT.

The average thickness across any cross section in the plating is not to be less than the renewal criteria for general corrosion given in Chapter 13 of CSR.

8.3 ACCEPTANCE CRITERIA FOR EDGE CORROSION OF CSR SHIPS

8.3.1 Provided that the overall corroded height of the edge corrosion of the flange, or web in the case of flat bar stiffeners, is less than 25%, see Figure 2, of the stiffener flange breadth or web height, as applicable, the measured thickness, t_m , is to meet the lesser of the following criteria:

$$t_m \geq 0.7 (t_{as-built} - t_{vol add}) \text{ mm}$$

$$t_m \geq t_{ren} - 1 \text{ mm}$$

8.3.2 The average measured thickness across the breadth or height of the stiffener is not to be less than that defined in IACS Common Structural Rules* (CSR).

* Ch.13 of IACS CSR for Bulk Carriers, or Ch. 13, Part 1 of IACS CSR BC & OT.

8.3.3 Plate edges at openings for manholes, lightening holes etc. may be below the minimum thickness given in IACS Common Structural Rules* (CSR) provided that:

- a) the maximum extent of the reduced plate thickness, below the minimum given in IACS Common Structural Rules* (CSR), from the opening edge is not more than 20% of the smallest dimension of the opening and does not exceed 100 mm.
- b) rough or uneven edges may be cropped-back provided that the maximum dimension of the opening is not increased by more than 10% and the remaining thickness of the new edge is not less than $t_{ren} - 1$ mm.

* Ch.13 of IACS CSR for Bulk Carriers, or Ch. 13, Part 1 of IACS CSR BC & OT.

8.4 ACCEPTANCE CRITERIA FOR GROOVING CORROSION OF CSR SHIPS

8.4.1 Where the groove breadth is a maximum of 15% of the web height, but not more than 30mm, see Figure 3, the measured thickness, t_m , in the grooved area is to meet the lesser of the following criteria:

$$t_m \geq 0.75 (t_{as-built} - t_{vol add}) \text{ mm}$$

$$t_m \geq t_{ren} - 0.5 \text{ mm}$$

but is not to be less than:

$$t_m = 6 \text{ mm}$$

8.4.2 Structural members with areas of grooving greater than those in 8.4.1 above are to be assessed based on the criteria for general corrosion as defined in IACS Common Structural Rules* (CSR) using the average measured thickness across the plating/stiffener.

* Ch.13 of IACS CSR for Bulk Carriers, or Ch. 13, Part 1 of IACS CSR BC & OT.

9 REPORTING AND EVALUATION OF SURVEY

9.1 EVALUATION OF SURVEY REPORT

9.1.1 The data and information on the structural condition of the vessel collected during the survey is to be evaluated for acceptability and continued structural integrity of the vessel.

9.1.1.1 For CSR bulk carriers, the ship's longitudinal strength is to be evaluated by using the thickness of structural members measured, renewed and reinforced, as appropriate, during the Renewal surveys carried out after the ship reached 15 years of age (or during the Renewal survey no. 3, if this is carried out before the ship reaches 15 years) in accordance with the criteria for longitudinal strength of the ship's hull girder for CSR bulk carriers specified in IACS Common Structural Rules* (CSR).

* Ch.13 of IACS CSR for Bulk Carriers, or Ch. 13, Part 1 of IACS CSR BC & OT.

9.1.1.2 The final result of evaluation of the ship's longitudinal strength required in 9.1.1.1, after renewal or reinforcement work of structural members, if carried out as a result of initial evaluation, is to be reported as a part of the Executive Hull Summary.

9.2 REPORTING

9.2.1 Principles for survey reporting are shown in the Table VII of IACS UR Z10.5.

9.2.2 When a survey is split between different survey stations, a report is to be made for each portion of the survey. A list of item examined and / or tested (pressure testing, thickness measurements etc.) and an indication of whether the item has been credited, are to be made available to the next attending Surveyor(s), prior to continuing or completing the survey.

9.2.3 An Executive Hull Summary of the survey and results is to be issued to the Owner as shown in Table VIII of IACS UR Z10.5 and placed on board the vessel for reference at future surveys. The Executive Hull Summary is to be endorsed by the Head Office of the Register.

Table I, Sheet 1
MINIMUM REQUIREMENTS FOR CLOSE-UP SURVEY AT RENEWAL HULL SURVEY OF DOUBLE SKIN BULK CARRIERS, EXCLUDING ORE CARRIERS

I Renewal survey age ≤ 5	II Renewal survey 5 < age ≤ 10	III Renewal survey 10 < age ≤ 15	IV Renewal survey subsequent surveys age > 15
One transverse web with associated plating and longitudinals in two representative water ballast tanks of each type (This is to include the foremost topside and double side water ballast tanks on either side). (A)	One transverse web with associated plating and longitudinals as applicable in each water ballast tank. (A) Forward and aft transverse bulkheads including stiffening system in a transverse section including topside, hopper side and double side ballast tanks on one side of the ships (i.e. port or starboard). (A) 25% of ordinary transverse frames for transverse framing system or 25% of longitudinals for longitudinal framing system on side shell and inner side plating at forward, middle and aft parts, in the foremost double side tanks. (B)	All transverse webs with associated plating and longitudinals as applicable in each water ballast tank. (A) All transverse bulkheads including stiffening system in each water ballast tank. (A) 25% of ordinary transverse frames for transverse framing system or 25% of longitudinals for longitudinal framing system on side shell and inner side plating at forward, middle and aft parts, in the in all double side tanks. (B)	All transverse webs with associated plating and longitudinals as applicable in each water ballast tank. (A) All transverse bulkheads including stiffening system in each water ballast tank. (A) All ordinary transverse frames for transverse framing system or 25% of longitudinals for longitudinal framing system on side shell and inner side plating at forward, middle and aft parts, in the in all double side tanks. (B) Areas (C) - (E) as for age interval 10 to 15 years.

I Renewal survey age ≤ 5	II Renewal survey 5 < age ≤ 10	III Renewal survey 10 < age ≤ 15	IV Renewal survey subsequent surveys age > 15
Two selected cargo hold transverse bulkheads, including internal structure of upper and lower stools, where fitted. (C)	One transverse bulkhead in each cargo hold, including internal structure of upper and lower stools, where fitted. (C)	All cargo hold transverse bulkheads, including internal structure of upper and lower stools, where fitted. (C)	
All cargo hold hatch covers and coamings (plating and stiffeners). (D)	All cargo hold hatch covers and coamings (plating and stiffeners). (D)	All cargo hold hatch covers and coamings (plating and stiffeners). (D)	
	All deck plating and under deck structure inside line of hatch openings between all cargo hold hatches. (E)	All deck plating and under deck structure inside line of hatch openings between all cargo hold hatches. (E)	

(A), (B), (C), (D) and (E) are areas to be subjected to close-up surveys and thickness measurements (see figures in Annex D).

- (A): Transverse web frame or watertight transverse bulkhead in topside, hopper side and double side ballast tanks. In fore and aft peak tanks transverse web frame means a complete transverse web frame ring including adjacent structural members.
- (B): Ordinary transverse frame in double side tanks.
- (C): Cargo hold transverse bulkheads plating, stiffeners and girders.
- (D): Cargo hold hatch covers and coamings. Subject to cargo hold hatch covers of approved design which structurally have no access to the internals, close-up survey/thickness measurement shall be done of accessible parts of hatch covers structures.
- (E): Deck plating and under deck structure inside line of hatch openings between cargo hold hatches.

NOTE: Close-up survey of transverse bulkheads to be carried out at four levels:

- Level (a): Immediately above the inner bottom and immediately above the line of gussets (if fitted) and shedders for ships without lower stool.
- Level (b): Immediately above and below the lower stool shelf plate (for those ships fitted with lower stools), and immediately above the line of the shedder plates.
- Level (c): About mid-height of the bulkhead.
- Level (d): Immediately below the upper deck plating and immediately adjacent to the upper wing tank, and immediately below the upper stool shelf plate for those ships fitted with upper stools, or immediately below the topside tanks.

Table I, Sheet 2
MINIMUM REQUIREMENTS FOR CLOSE-UP SURVEY AT RENEWAL HULL SURVEY OF ORE CARRIERS

I Renewal survey age ≤ 5	II Renewal survey 5 < age ≤ 10	III Renewal survey 10 < age ≤ 15	IV Renewal survey subsequent surveys age > 15
<p>One web frame ring complete including adjacent structural members in a ballast wing tank. (A)</p> <p>One transverse bulkhead lower part - including girder system and adjacent structural members - in a ballast tank. (A)</p>	<p>All web frame rings complete including adjacent structural members in a ballast wing tank. (A)</p> <p>One deck transverse including adjacent deck structural members in each remaining ballast tank. (A)</p> <p>Forward and aft transverse bulkheads complete - including girder system and adjacent structural members - in a ballast wing tank. (A)</p> <p>One transverse bulkhead lower part - including girder system and adjacent structural members - in each remaining ballast tank. (A)</p>	<p>All transverse bulkheads complete - including girder system and adjacent structural members - in each ballast tank. (A)</p> <p>One web frame ring complete including adjacent structural members in each wing void space. (A)</p> <p>One web frame ring complete including adjacent structural members in each wing void space. (A)</p> <p>Additional web frame rings in void spaces as deemed necessary by the <i>Register</i>. (A)</p>	<p>As for Renewal survey for age from 10 to 15 years.</p>
<p>Two selected cargo hold transverse bulkheads, including internal structure of upper and lower stools, where fitted. (C)</p>	<p>One transverse bulkhead in each cargo hold, including internal structure of upper and lower stools, where fitted. (C)</p>	<p>All cargo hold transverse bulkheads, including internal structure of upper and lower stools, where fitted. (C)</p>	<p>Areas (C) - (E) as for age interval 10 to 15 years.</p>
<p>All cargo hold hatch covers and coamings (plating and stiffeners). (D)</p>	<p>All cargo hold hatch covers and coamings (plating and stiffeners). (D)</p>	<p>All cargo hold hatch covers and coamings (plating and stiffeners). (D)</p>	
	<p>All deck plating and under deck structure inside line of hatch openings between all cargo hold hatches. (E)</p>	<p>All deck plating and under deck structure inside line of hatch openings between all cargo hold hatches. (E)</p>	
<p>(A), (C), (D) and (E) are areas to be subjected to close-up surveys and thickness measurements (see figures in Annex D).</p> <p>(A): Transverse web frame or watertight transverse bulkhead in topside, hopper side and double side ballast tanks. In fore and aft peak tanks transverse web frame means a complete transverse web frame ring including adjacent structural members.</p> <p>(C): Cargo hold transverse bulkheads plating, stiffeners and girders.</p> <p>(D): Cargo hold hatch covers and coamings. Subject to cargo hold hatch covers of approved design which structurally have no access to the internals, close-up survey/thickness measurement shall be done of accessible parts of hatch covers structures.</p> <p>(E): Deck plating and under deck structure inside line of hatch openings between cargo hold hatches.</p> <p>NOTE: Close-up survey of transverse bulkheads to be carried out at four levels:</p> <p>Level (a): Immediately above the inner bottom and immediately above the line of gussets (if fitted) and shedders for ships without lower stool.</p> <p>Level (b): Immediately above and below the lower stool shelf plate (for those ships fitted with lower stools), and immediately above the line of the shedder plates.</p> <p>Level (c): About mid-height of the bulkhead.</p> <p>Level (d): Immediately below the upper deck plating and immediately adjacent to the upper wing tank, and immediately below the upper stool shelf plate for those ships fitted with upper stools, or immediately below the topside tanks.</p>			

Table II
MINIMUM REQUIREMENTS TO THICKNESS MEASUREMENTS AT RENEWAL HULL SURVEY OF DOUBLE SKIN BULK CARRIERS

I Renewal survey age ≤ 5	II Renewal survey 5 < age ≤ 10	III Renewal survey 10 < age ≤ 15	IV Renewal survey subsequent surveys age > 15
Suspect area	Suspect area	Suspect areas	Suspect areas
	Within the cargo length: - two transverse sections of deck plating outside line of cargo hatch openings	Within the cargo length: - each deck plate outside line of cargo hatch openings - two transverse sections, one in the amidship area, outside line of cargo hatch openings - all wind and water strakes	Within the cargo length: - each deck plate outside line of cargo hatch openings - three transverse sections, one in the amidship area, outside line of cargo hatch openings - each bottom plate
	Wind and water strakes in way of the two transverse sections considered above Selected wind and water strakes outside the cargo length area	Selected wind and water strakes outside the cargo length area	All wind and water strakes, full length
	Measurements, for general assessment and recording of corrosion pattern, of those structural members subject to close-up survey according to Table I/Sheet 1 or Table I/Sheet 2, as applicable.	Measurements, for general assessment and recording of corrosion pattern, of those structural members subject to close-up survey according to Table I/Sheet 1 or Table I/Sheet 2, as applicable.	Measurements, for general assessment and recording of corrosion pattern, of those structural members subject to close-up survey according to Table I/Sheet 1 or Table I/Sheet 2, as applicable.

TABLE III

Ship Name:						
OWNERS INSPECTION REPORT - Structural Condition						
For Tank/Hold No:						
Grade of Steel:		Deck	:	Side	:	
		Bottom	:	Long. Bhd	:	
Elements	Cracks	Buckles	Corrosion	Coating cond.	Pitting	Mod. /Rep.
Other						
Deck:						
Bottom:						
Side:						
Long. Bulkheads:						
Transv. Bulkheads:						
Repairs carried out due to:						
Thickness measurements carried out, dates:						
Results in General:						
Overdue Surveys:						
Outstanding Conditions of class:						
Comments:						
*Repairs are to be surveyed by the classification society						
Date of Inspection: _____						
Inspected by: _____						
Signature: _____						

Table IV, Sheet 1
REQUIREMENTS FOR EXTENT OF THICKNESS MEASUREMENTS AT THOSE AREAS OF SUBSTANTIAL CORROSION OF DOUBLE SKIN BULK CARRIERS WITHIN THE CARGO LENGTH AREA

BOTTOM, INNER BOTTOM AND HOPPER STRUCTURE		
Structural member	Extent of measurement	Pattern of measurement
<i>Bottom, inner bottom and hopper structure plating</i>	<ul style="list-style-type: none"> - Minimum of three bays across double bottom tank, including aft bay - Measurements around and under all suction bell mouths 	- 5-point pattern for each panel between longitudinals and floors
<i>Bottom, inner bottom and hopper structure longitudinals</i>	- Minimum of three longitudinals in each bay where bottom plating measured	- Three measurements in line across flange and three measurements on vertical web
<i>Bottom girders, including the watertight ones</i>	- At fore and aft watertight floors and in centre of tanks	- Vertical line of single measurements on girder plating with one measurement between each panel stiffener, or a minimum of three measurements
<i>Bottom floors, including the watertight ones</i>	- Three floors in bays where bottom plating measured, with measurements at both ends and middle	- 5-point pattern over two square metre area
<i>Hopper structure web frame ring</i>	- Three floors in bays where bottom plating measured	<ul style="list-style-type: none"> - 5-point pattern over one square metre of plating. - Single measurements on flange
<i>Hopper structure transverse watertight bulkhead or swash bulkhead</i>	- Lower 1/3 of bulkhead	- 5-point pattern over one square metre of plating
	- Upper 2/3 of bulkhead	- 5-point pattern over two square metre of plating
	- Stiffeners (minimum of three)	- For web, 5-point pattern over span (two measurements across web at each end and one at centre of span). For flange, single measurements at each end and centre of span
<i>Panel stiffening</i>	- Where applicable	- Single measurements

Table IV, Sheet 2
REQUIREMENTS FOR EXTENT OF THICKNESS MEASUREMENTS AT THOSE AREAS OF SUBSTANTIAL
CORROSION OF DOUBLE SKIN BULK CARRIERS WITHIN THE CARGO LENGTH AREA

DECK STRUCTURE INCLUDING CROSS STRIPS, MAIN CARGO HATCHWAYS, HATCH COVERS, COAMINGS AND TOPSIDE TANKS		
Structural member	Extent of measurement	Pattern of measurement
<i>Cross Deck Strip plating</i>	Suspect Cross Deck Strip plating	5-point pattern between underdeck stiffeners over 1 metre length
<i>Underdeck Stiffeners</i>	Transverse members Longitudinal member	5-point pattern at each end and mid span 5-point pattern on both web and flange
<i>Hatch Covers</i>	Side and end skirts, each three locations Three longitudinal bands, outboard strakes (2) and centreline strake (1)	5-point pattern at each location 5-point measurement each band
<i>Hatch Coamings</i>	Each side and end of coaming, one band lower 1/3, one band upper 2/3 of coaming	5-point measurement each band, i.e. end or side coaming
<i>Topside Ballast Tanks</i>	a) watertight transverse bulkheads: - Lower 1/3 of bulkhead - Upper 2/3 of bulkhead - Stiffeners	5-point pattern over 1 sq. metre of plating 5-point pattern over 1 sq. metre of plating 5-point pattern over 1 metre length
<i>Topside Ballast Tanks</i>	b) two representative swash transverse bulkheads: - Lower 1/3 of bulkhead - Upper 2/3 of bulkhead - Stiffeners	5-point pattern over 1 sq. metre of plating 5-point pattern over 1 sq. metre of plating 5-point pattern over 1 metre length
<i>Topside Ballast Tanks</i>	c) three representative bays of slope plating: - Lower 1/3 of tank - Upper 2/3 of tank	5-point pattern over 1 sq. metre of plating 5-point pattern over 1 sq. metre of plating
<i>Topside Ballast Tanks</i>	d) Longitudinals, suspect and adjacent	5-point pattern on both web and flange over 1 metre length
<i>Main Deck Plating</i>	Suspect plates and adjacent (4)	5-point pattern over 1 sq. metre of plating
<i>Main Deck Longitudinals</i>	Suspect plates	5-point pattern on both web and flange over 1 metre length
<i>Web Frames/Transverses</i>	Suspect plates	5-point pattern over 1 sq. metre

Table IV, Sheet 3
REQUIREMENTS FOR EXTENT OF THICKNESS MEASUREMENTS AT THOSE AREAS OF SUBSTANTIAL CORROSION OF DOUBLE SKIN BULK CARRIERS WITHIN THE CARGO LENGTH AREA

STRUCTURE IN DOUBLE SIDE SPACES OF DOUBLE SKIN BULK CARRIERS INCLUDING WING VOID SPACES OF ORE CARRIERS		
Structural member	Extent of measurement	Pattern of measurement
<i>Side shell and inner side plating:</i> - upper strake and strakes in way of horizontal girders - all other strakes	- Plating between each pair of transverse frames /longitudinals in a minimum of three bays (along the tank) - Plating between every third pair of longitudinals in same three bays	- Single measurement - Single measurement
<i>Side shell and inner side transverse frames/longitudinals on:</i> - upper strake - all other strakes	- Each transverse frame/longitudinal in same three bays - Every third transverse frame/longitudinal in same three bays	- Three measurements across web and 1 measurement on flange - Three measurements across web and 1 measurement on flange
<i>Transverse frames / Longitudinals:</i> - brackets	- Minimum of three at top, middle and bottom of tank in same three bays	- 5-point pattern over area of bracket
<i>Vertical web and transverse bulkheads:</i> - strakes in way of horizontal girders - other strakes	- Minimum of two webs and both transverse bulkheads - Minimum of two webs and both transverse bulkheads	- 5-point pattern over approx. two square metre area - Two measurements between each pair of vertical stiffeners
<i>Horizontal girders</i>	- Plating on each girder in a minimum of three bays	- Two measurements between each pair of longitudinal girder stiffeners
<i>Panel stiffening</i>	- Where applicable	- Single measurements

Table IV, Sheet 4
REQUIREMENTS FOR EXTENT OF THICKNESS MEASUREMENTS AT THOSE AREAS OF SUBSTANTIAL CORROSION OF DOUBLE SKIN BULK CARRIERS WITHIN THE CARGO LENGTH AREA

TRANSVERSE BULKHEADS IN CARGO HOLDS		
Structural member	Extent of measurement	Pattern of measurement
<i>Lower stool, where fitted</i>	<ul style="list-style-type: none"> - Transverse band within 25mm of welded connection to inner bottom - Transverse band within 25mm of welded connection to shelf plate 	<ul style="list-style-type: none"> - 5-point pattern between stiffeners over one metre length - 5-point pattern between stiffeners over one metre length
<i>Transverse bulkheads</i>	<ul style="list-style-type: none"> - Transverse band at approximately mid height - Transverse band at part of bulkhead adjacent to upper deck or below upper stool shelf plate (for those ships fitted with upper stools) 	<ul style="list-style-type: none"> - 5-point pattern over one square metre of plating - 5-point pattern over one square metre of plating

Table V
MINIMUM REQUIREMENTS OF OVERALL AND CLOSE-UP SURVEY AND THICKNESS MEASUREMENTS AT INTERMEDIATE SURVEY OF DOUBLE SKIN BULK CARRIERS

AGE OF SHIP AT TIME OF INTERMEDIATE SURVEY DUE DATE		
5 < age ≤ 10	10 < age ≤ 15	age > 15
Overall survey of Representative ballast tanks selected by the attending Surveyor (the selection is to include fore and aft peak tanks, and a number of other tanks, taking into account the total number and type of ballast tanks)	The requirements of the previous Renewal survey See (4.2.3)	The requirements of the previous Renewal survey See (4.2.4)
Overall and close-up survey of Suspect Areas identified at previous surveys		
Overall survey of all cargo holds		
Thickness measurements to an extent sufficient to determine both general and local corrosion levels at areas subject to close-up survey at 'suspect areas' identified at previous surveys		

ANNEX D
Sketches

**Oil tankers, ore/oil ships, etc.
 Close up survey requirements**

Oil tanker
 Typical transverse section Close-up survey

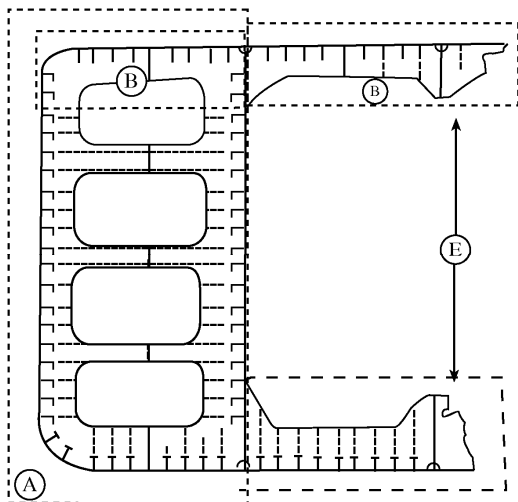

Oil tanker
 Typical transverse bulkhead

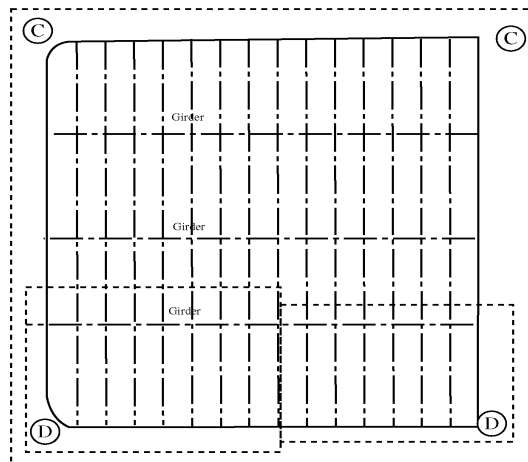

Oil/ore ship
 Typical transverse section Close-up survey

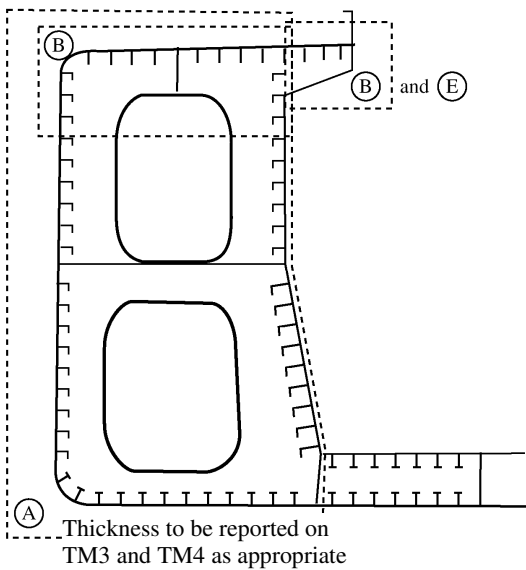

Oil/ore ship
 Typical transverse bulkhead

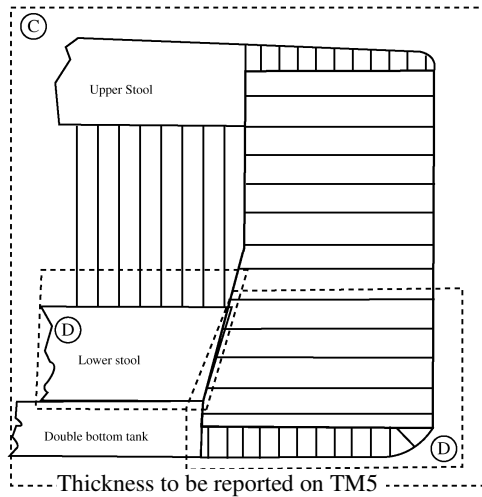

Close-up survey
 area

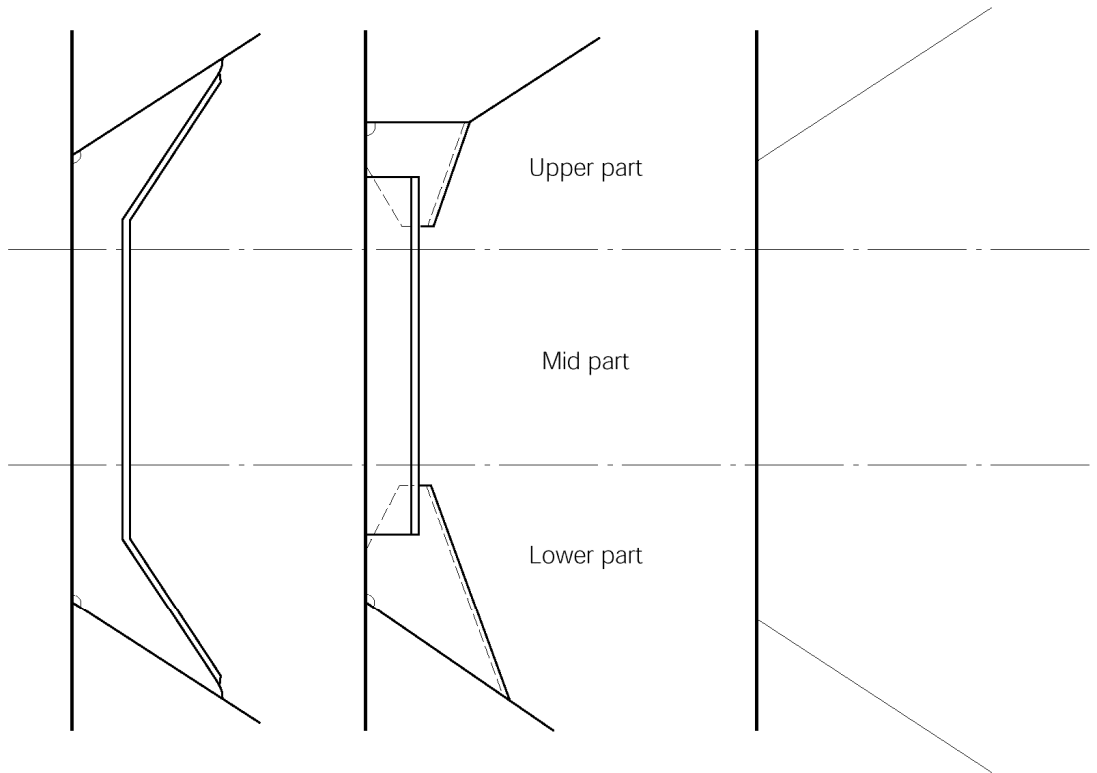

Typical transverse frames in cargo hold
Thickness gauging area (A)

Non - typical transverse
frame in cargo hold
Thickness gauging area (A)

Close-up survey and thickness measurement areas
BULK CARRIER – Areas subject to close-up survey and thickness measurements

Typical transverse section

Areas (A), (B) and (D)

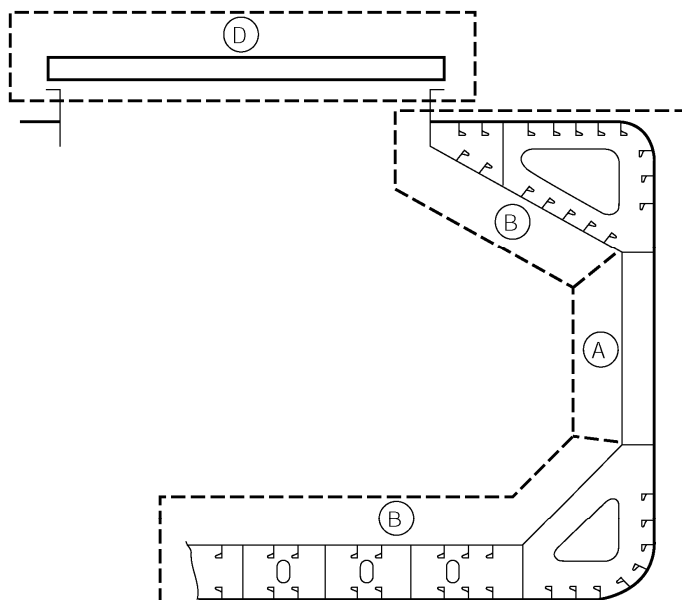

A cargo hold, transverse bulkhead

Area (C)

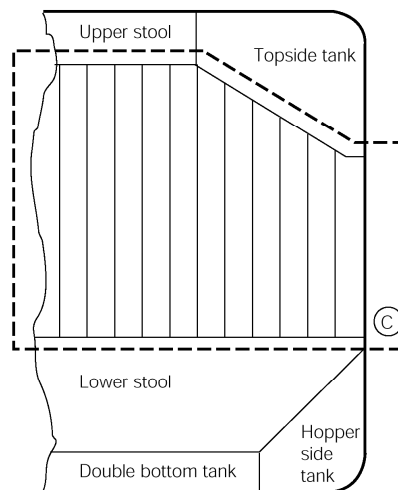

Typical areas of deck plating inside line of hatch openings between cargo hold hatches

Area (E)

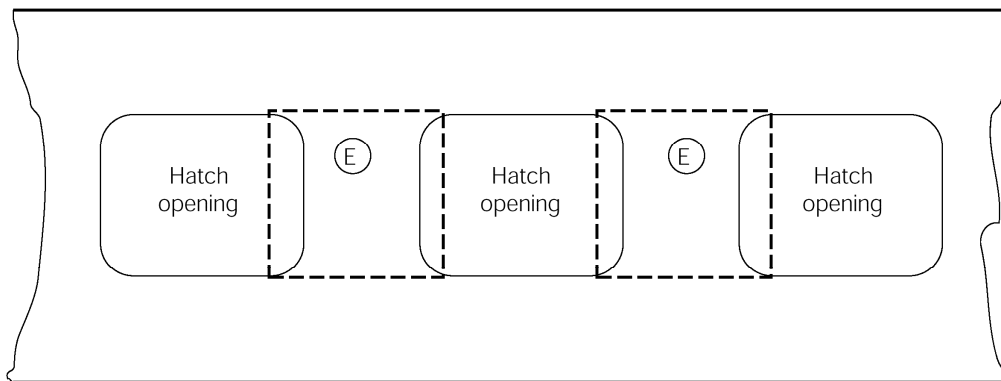

Close-up survey and thickness measurement

TANKER FOR OIL - Typical transverse section indication longitudinal and transverse members

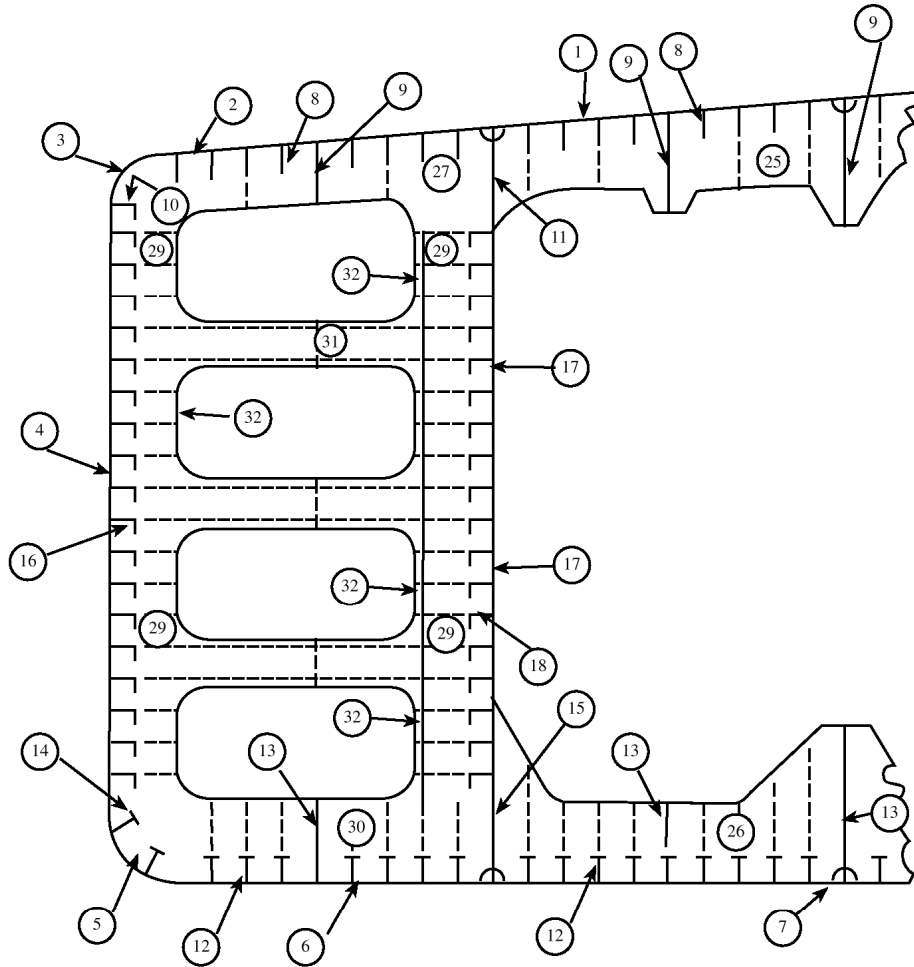

Report on TM2 (1) & (2)
1. Strength deck plating 2. Stringer plate 3. Sheerstrake 4. Side shell plating 5. Bilge plating 6. Bottom shell plating 7. Keel plate

Report on TM2 (1) & (2)
36. Hatch coamings 37. Deck plating between hatches 38. Hatch covers 39. 40.

Report on TM3
8. Deck longitudinals 9. Deck girders 10. Sheerstrake longitudinals 11. Longitudinal bulkhead top strake 12. Bottom longitudinals 13. Bottom girders 14. Bilge longitudinals 15. Longitudinal bulkhead lower strake 16. Side shell longitudinals 17. Longitudinal bulkhead plating (remainder) 18. Longitudinal bulkhead longitudinals 19. Inner bottom plating 20. Inner bottom longitudinals 21. 22. 23. 24.

Report on TM4
25. Deck transverse centre tank 26. Bottom transverse centre tank 27. Deck transverse wing tank 28. Side shell vertical web 29. Longitudinal bulkhead vertical web 30. Bottom transverse wing tank 31. Struts 32. Transverse web face plate 33. D.B. Floors 34. 35.

Close-up survey and thickness measurement
BULK CARRIER - Typical transverse section indication longitudinal and transverse members

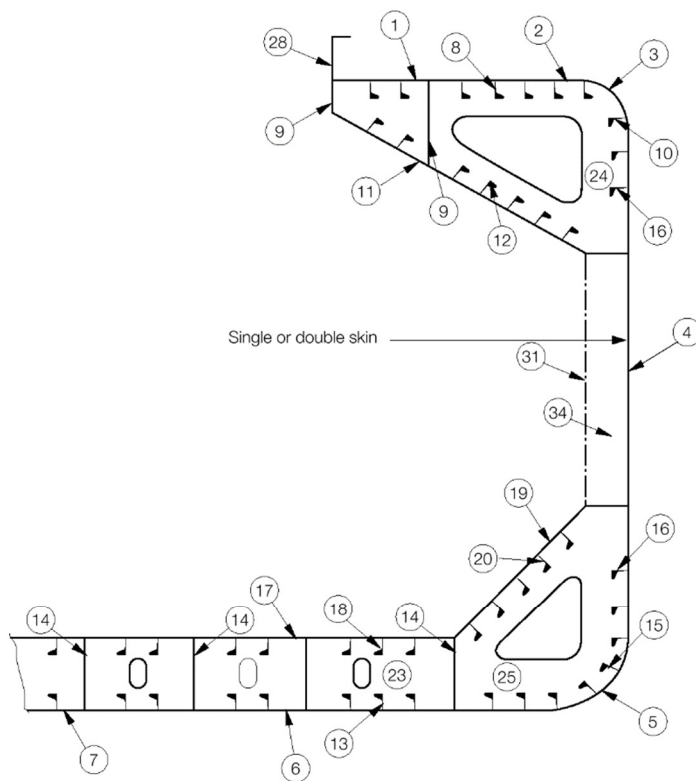

Report on TM2	
①	Strength deck plating
②	Stringer plate
③	Sheerstrake
④	Side shell plating
⑤	Bilge plating
⑥	Bottom shell plating
⑦	Keel plate

Report on TM3			
⑧	Deck longitudinals	⑩	Sheerstrake longitudinals
⑨	Deck girders	⑪	Topside tank sloping plating
⑫	Topside tank sloping plating longitudinals	⑬	Bottom longitudinals
⑭	Bottom girders	⑮	Bilge Longitudinals
⑯	Side shell longitudinals	⑰	Inner bottom plating
⑱	Inner bottom longitudinals	⑲	Hopper side plating
⑳	Hopper side longitudinals	㉑	
㉒		㉒	

Report on TM4	
㉓	Double bottom tank floors
㉔	Topside tank transverses
㉕	Hopper side tank transverses
㉖	
㉗	

Report on TM6	
㉘	Hatch coamings
㉙	Deck plating between hatches
㉚	Hatch covers
㉛	Inner bulkhead plating
㉜	
㉝	

Report on TM7	
㉞	Hold frames or diaphragms

CHEMICAL TANKER

Representative transverse section of double skin chemical tanker. Areas A & B and 1 and 2

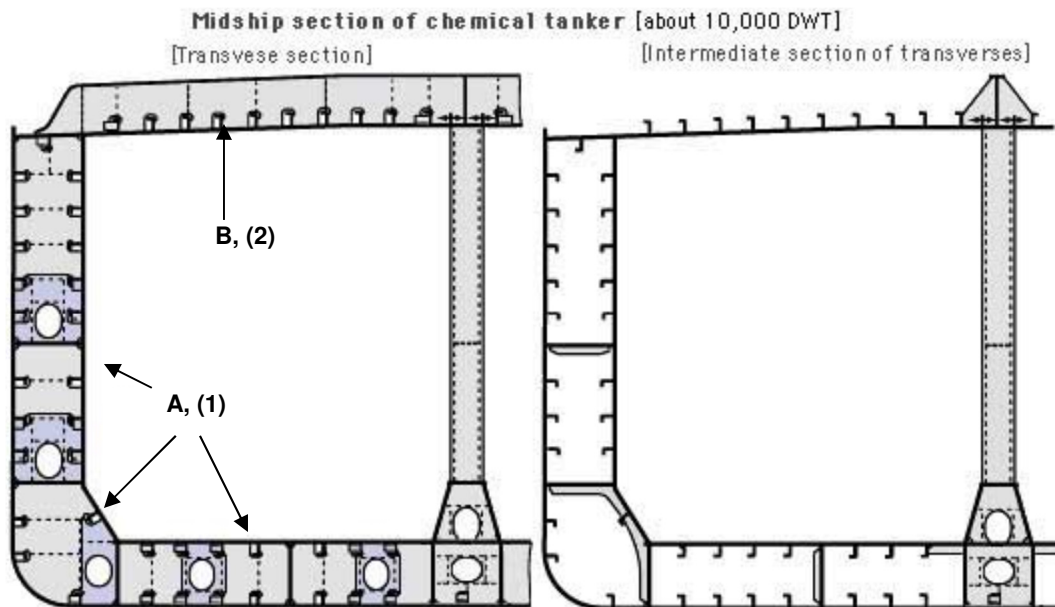

Representative transverse section of double skin chemical tanker. Areas C & D and 3, 4 and 5

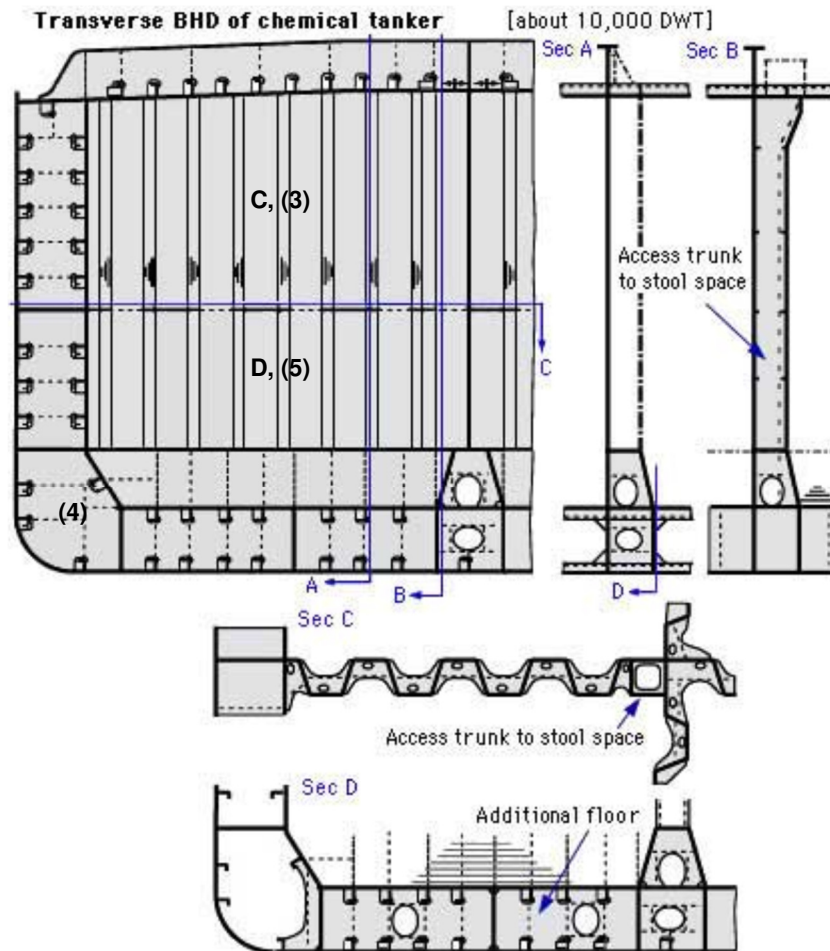

Representative transverse section of double skin chemical tanker. Areas 6 and 7

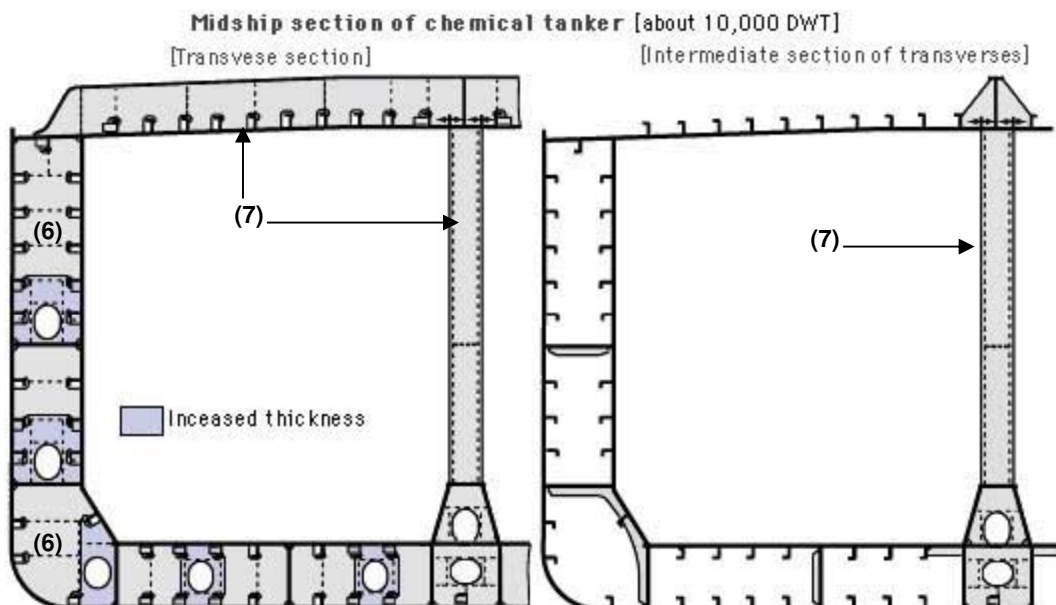

Close-up survey and thickness measurement
TANKER FOR OIL / ORE CARRIER - Typical transverse section indication longitudinal and transverse members

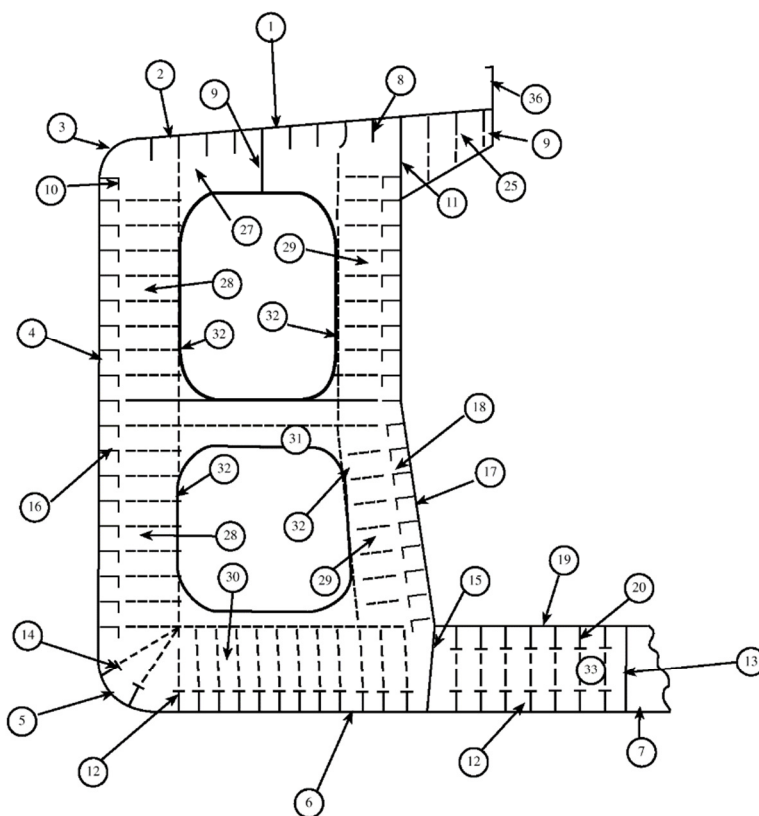

Report on TM2-T (1) & (2)
1. Strength deck plating 2. Stringer plate 3. Sheerstrake 4. Side shell plating 5. Bilge plating 6. Bottom shell plating 7. Keel plate

Report on TM2-T (1) & (2)
36. Hatch coamings 37. Deck plating between hatches 38. Hatch covers 39. 40.

Report on TM3-T
8. Deck longitudinals 9. Deck girders 10. Sheerstrake longitudinals 11. Longitudinal bulkhead top strake 12. Bottom longitudinals 13. Bottom girders 14. Bilge longitudinals 15. Longitudinal bulkhead lower strake 16. Side shell longitudinals 17. Longitudinal bulkhead plating (remainder) 18. Longitudinal bulkhead longitudinals 19. Inner bottom plating 20. Inner bottom longitudinals 21. 22. 23. 24.

Report on TM4-T
25. Deck transverse centre tank 26. Bottom transverse centre tank 27. Deck transverse wing tank 28. Side shell vertical web 29. Longitudinal bulkhead vertical web 30. Bottom transverse wing tank 31. Struts 32. Transverse web face plate 33. D.B. Floors 34. 35.

Close-up survey and thickness measurement
DOUBLE HULL OIL TANKER – Areas subject to close-up survey and thickness measurements – areas (1) to (5) as defined in Table I of Annex “C”

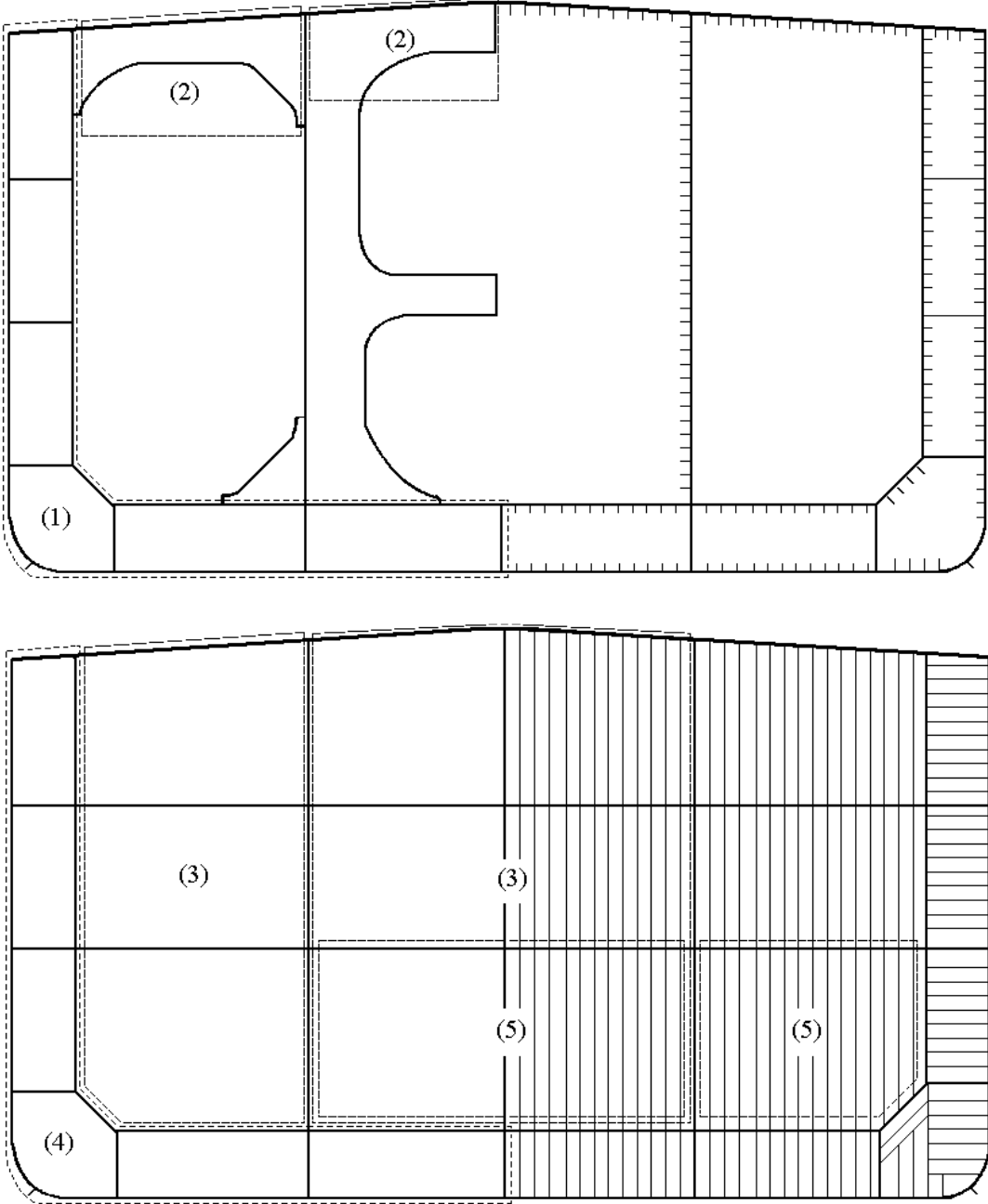

Close-up survey and thickness measurement

DOUBLE HULL OIL TANKER – Areas subject to close-up survey and thickness measurements – areas (6) to (7) as defined in Table I of Annx “C”

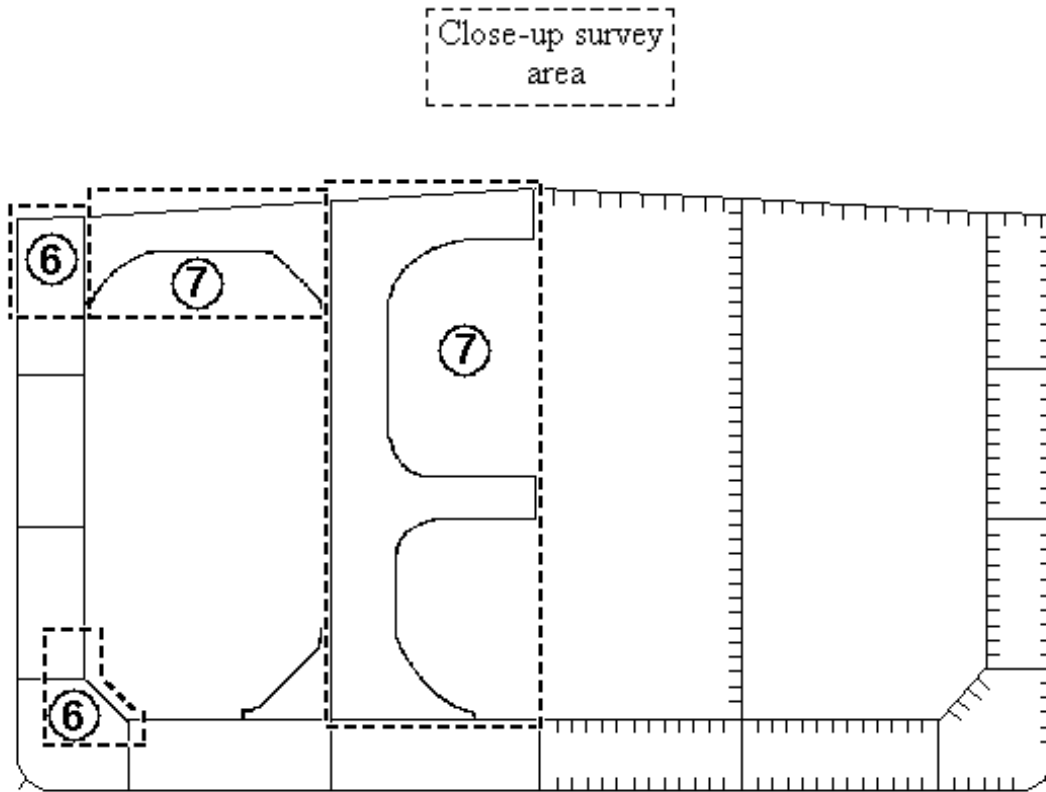

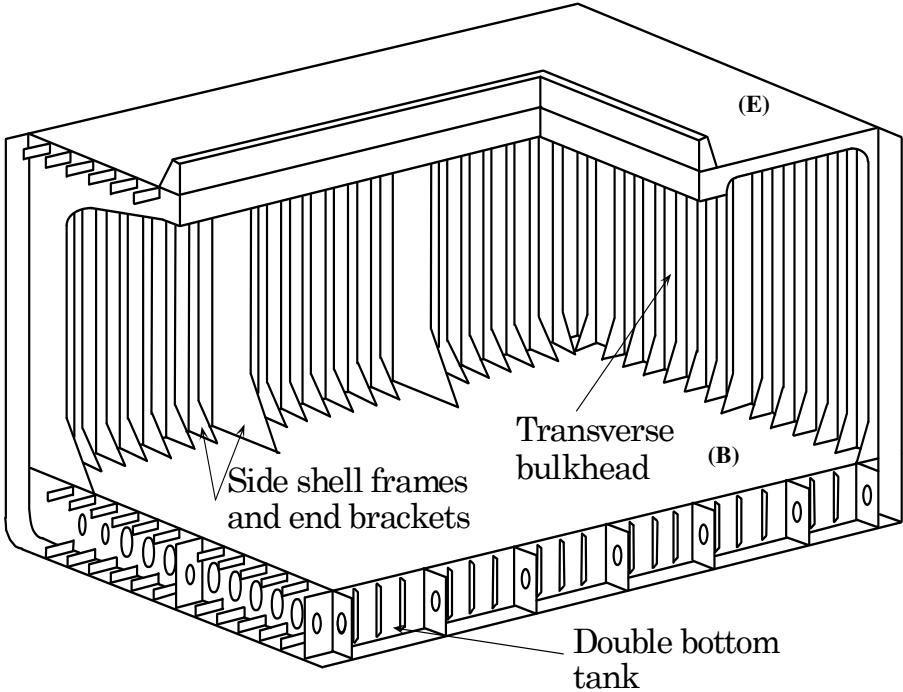

(a) Single Deck Ship

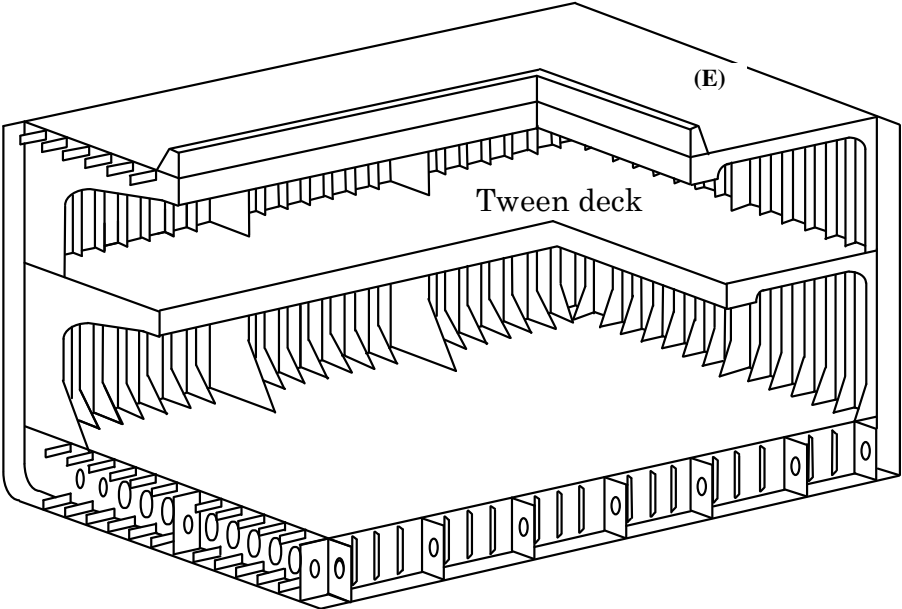

(b) Tween Deck Ship

**General dry cargo ships
Close-up survey and thickness measurement**

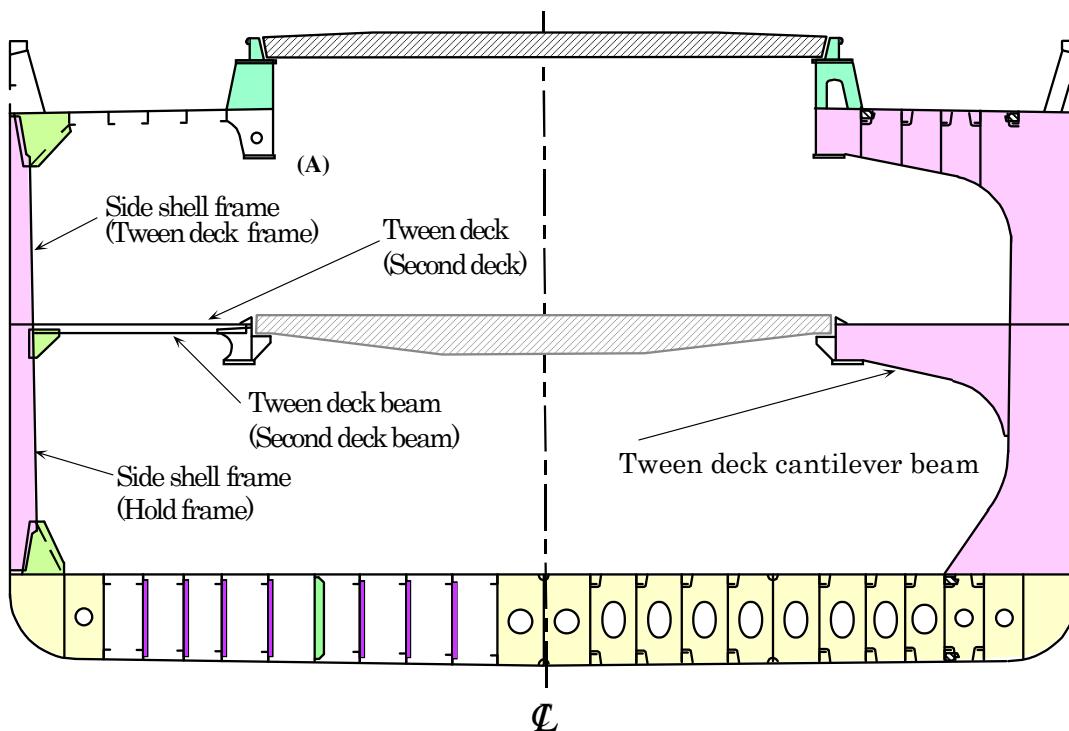
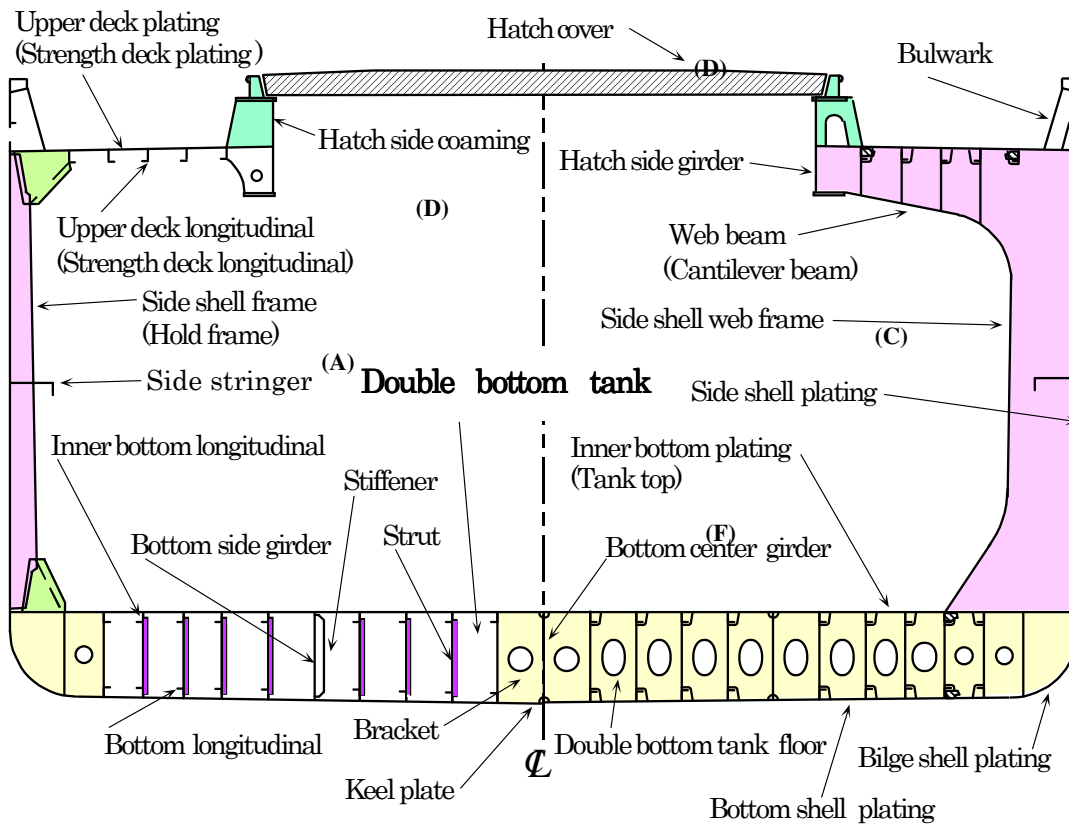

General dry cargo ships Close-up survey and thickness measurement areas

Close-up survey and thickness measurement
DOUBLE SKIN BULK CARRIERS - Typical transverse section indication longitudinal and transverse members

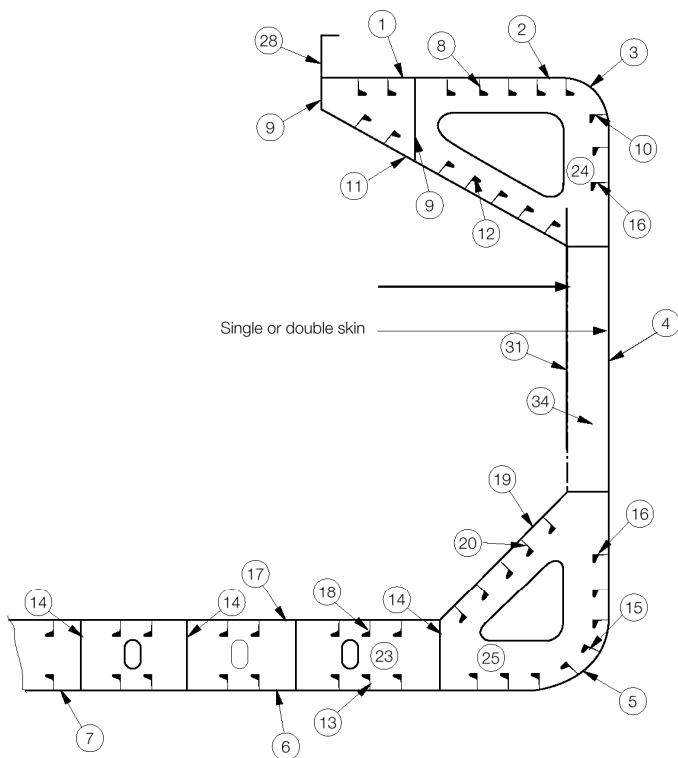

Report on TM2	Report on TM3-BC	
<ul style="list-style-type: none"> ① Strength deck plating ② Stringer plate ③ Sheerstrake ④ Side shell plating ⑤ Bilge plating ⑥ Bottom shell plating ⑦ Keel plate 	<ul style="list-style-type: none"> ⑧ Deck longitudinals ⑨ Deck girders ⑩ Sheerstrake longitudinals ⑪ Topside tank sloping plating ⑫ Topside tank sloping plating longitudinals ⑬ Bottom longitudinals ⑭ Bottom girders ⑮ Bilge Longitudinals 	<ul style="list-style-type: none"> ⑯ Side shell longitudinals ⑰ Inner bottom plating ⑱ Inner bottom longitudinals ⑲ Hopper side plating ⑳ Hopper side longitudinals ㉑ ㉒
Report on TM4	Report on TM6-BC	Report on TM7-BC
<ul style="list-style-type: none"> ㉓ Double bottom tank floors ㉔ Topside tank transverses ㉕ Hopper side tank transverses ㉖ ㉗ 	<ul style="list-style-type: none"> ㉘ Hatch coamings ㉙ Deck plating between hatches ㉚ Hatch covers ㉛ Inner bulkhead plating ㉜ ㉝ 	<ul style="list-style-type: none"> ㉞ Hold frames or diaphragms

ANNEX E

Periodic Survey of Fuel Installations on Ships Other Than Liquefied Gas Carriers Utilizing Gas or Other Low Flash Point Fuels

Annex E **PERIODIC SURVEY OF FUEL
INSTALLATIONS ON SHIPS OTHER THAN
LIQUEFIED GAS CARRIERS UTILIZING
GAS OR OTHER LOW FLASH POINT FUELS**

Contents:

	Page
1 GENERAL.....	1
1.1 APPLICATION	1
2 RENEWAL SURVEY	1
3 ANNUAL SURVEY	1
4 INTERMEDIATE SURVEY	1

1 GENERAL

1.1 APPLICATION

1.1.1 These requirements apply to ships, other than ships carrying liquefied gases in bulk, which utilize gas or other low flash point fuels as a fuel for propulsion prime mover/auxiliary power generation arrangements and associated systems and to which additional character of class **GF** is assigned. These requirements are in addition to the requirements for Survey of machinery (contained in the main text of the *Rules for the classification of ships, Part 1 – General requirements, Chapter 5 – Survey of ships in service*).

These survey requirements do not cover fire protection, fire-fighting installation, and personnel protection equipment.

2 RENEWAL SURVEY

2.1 Requirements of the *Rules for the classification of ships, Part 33 – Ships using gases or other low-flashing fuel*, Annex 3, Section 2 should apply.

3 ANNUAL SURVEY

3.1 Requirements of the *Rules for the classification of ships, Part 33 – Ships using gases or other low-flashing fuel*, Annex 3, Section 3 should apply.

4 INTERMEDIATE SURVEY

4.1 Requirements of the *Rules for the classification of ships, Part 33 – Ships using gases or other low-flashing fuel*, Annex 3, Section 4 should apply.